

[MS-DTSX2]: Data Transformation Services Package XML Version 2 File Format Specification

Intellectual Property Rights Notice for Open Specifications Documentation

- **Technical Documentation.** Microsoft publishes Open Specifications documentation for protocols, file formats, languages, standards as well as overviews of the interaction among each of these technologies.
- **Copyrights.** This documentation is covered by Microsoft copyrights. Regardless of any other terms that are contained in the terms of use for the Microsoft website that hosts this documentation, you may make copies of it in order to develop implementations of the technologies described in the Open Specifications and may distribute portions of it in your implementations using these technologies or your documentation as necessary to properly document the implementation. You may also distribute in your implementation, with or without modification, any schema, IDL's, or code samples that are included in the documentation. This permission also applies to any documents that are referenced in the Open Specifications.
- **No Trade Secrets.** Microsoft does not claim any trade secret rights in this documentation.
- **Patents.** Microsoft has patents that may cover your implementations of the technologies described in the Open Specifications. Neither this notice nor Microsoft's delivery of the documentation grants any licenses under those or any other Microsoft patents. However, a given Open Specification may be covered by Microsoft [Open Specification Promise](#) or the [Community Promise](#). If you would prefer a written license, or if the technologies described in the Open Specifications are not covered by the Open Specifications Promise or Community Promise, as applicable, patent licenses are available by contacting iplg@microsoft.com.
- **Trademarks.** The names of companies and products contained in this documentation may be covered by trademarks or similar intellectual property rights. This notice does not grant any licenses under those rights.
- **Fictitious Names.** The example companies, organizations, products, domain names, e-mail addresses, logos, people, places, and events depicted in this documentation are fictitious. No association with any real company, organization, product, domain name, email address, logo, person, place, or event is intended or should be inferred.

Reservation of Rights. All other rights are reserved, and this notice does not grant any rights other than specifically described above, whether by implication, estoppel, or otherwise.

Tools. The Open Specifications do not require the use of Microsoft programming tools or programming environments in order for you to develop an implementation. If you have access to Microsoft programming tools and environments you are free to take advantage of them. Certain Open Specifications are intended for use in conjunction with publicly available standard specifications and network programming art, and assumes that the reader either is familiar with the aforementioned material or has immediate access to it.

Revision Summary

Date	Revision History	Revision Class	Comments
02/09/2011	0.1	New	Released new document.
07/07/2011	0.1	Major	Significantly changed the technical content.
11/03/2011	0.1	No change	No changes to the meaning, language, or formatting of the technical content.
01/19/2012	0.1	No change	No changes to the meaning, language, or formatting of the technical content.

Contents

1	Introduction	16
1.1	Glossary	16
1.2	References	22
1.2.1	Normative References	22
1.2.2	Informative References	23
1.3	Overview	24
1.4	Relationship to Protocols and Other Structures	27
1.5	Applicability Statement	27
1.6	Versioning and Localization	27
1.7	Vendor-Extensible Fields	27
2	Structures	29
2.1	Additional Normative Requirements Concerning the XSD Fragments Provided	29
2.1.1	Constraints beyond the XSD Definitions for Complex Types	29
2.1.2	<xs:sequence> Usage Expressed in the XSD is Optional	29
2.2	Namespaces	29
2.3	Executable Element	30
2.4	ExecutableTypePackage	30
2.4.1	PackageVariablesType	33
2.4.1.1	PackageVariableType	34
2.4.1.1.1	PackageVariablePropertyNameEnum	35
2.4.2	ConfigurationsType	36
2.4.2.1	ConfigurationType	36
2.4.2.1.1	ConfigurationAttributeGroup	37
2.4.2.1.1.1	ConfigurationTypeEnum	38
2.4.3	LogProviderType	39
2.4.3.1	LogProviderAttributeGroup	40
2.4.3.2	LogProviderObjectDataType	40
2.4.4	ConnectionManagersType	41
2.4.4.1	ConnectionManagerType	41
2.4.4.1.1	ConnectionManagerAttributeGroup	42
2.4.4.1.2	ConnectionManagerObjectDataType	43
2.4.4.1.2.1	ConnectionManagerObjectDataConnectionManagerType	45
2.4.4.1.2.1.1	ConnectionManagerConnectionManagerAttributeGroup	46
2.4.4.1.2.1.1.1	FormatEnum	49
2.4.4.1.2.1.1.2	FileUsageTypeEnum	49
2.4.4.1.2.1.2	FlatFileColumnsType	50
2.4.4.1.2.1.2.1	FlatFileColumnType	50
2.4.4.1.2.1.2.1.1	FlatFileColumnAttributeGroup	51
2.4.4.1.2.1.2.1.2	ColumnTypeEnum	52
2.4.4.1.2.1.3	CacheColumnsType	52
2.4.4.1.2.1.3.1	CacheColumnType Complex Type	52
2.4.4.1.2.1.3.1.1	CacheColumnAttributeGroup	53
2.4.4.1.2.1.4	FtpConnectionType Complex Type	54
2.4.4.1.2.1.4.1	FtpConnectionPropertyNameEnum	55
2.4.4.1.2.1.4.2	FtpConnectionAttributeGroup	56
2.4.4.1.2.1.5	HttpConnectionType Complex Type	57
2.4.4.1.2.1.5.1	HttpConnectionPropertyNameEnum	58
2.4.4.1.2.1.5.2	HttpConnectionAttributeGroup	58
2.4.4.1.2.2	ConnectionManagerObjectDataMsmqConnectionManagerType	60

2.4.4.1.2.3	ConnectionManagerObjectDataSMOServerConnectionManagerType.....	61
2.4.4.1.2.4	ConnectionManagerObjectDataSmtpConnectionManagerType	61
2.4.4.1.2.5	ConnectionManagerObjectDataWmiConnectionManagerType	62
2.4.4.1.3	ConnectionManagerObjectDataType Information for Data Sources	62
2.4.4.1.3.1	OLE DB Data Source	63
2.4.4.1.3.2	Flat File Data Source	63
2.4.4.1.3.3	ADO.NET Data Source	65
2.4.4.1.3.4	Analysis Services Data Source.....	66
2.4.4.1.3.5	File Data Source	66
2.4.4.1.3.6	Cache Data Source	67
2.4.4.1.3.7	Excel Data Source	68
2.4.4.1.3.8	FTP Data Source.....	69
2.4.4.1.3.9	HTTP Data Source	70
2.4.4.1.3.10	MSMQ Data Source	70
2.4.4.1.3.11	MULTIFILE Data Source	71
2.4.4.1.3.12	MULTIFLATFORM Data Source	72
2.4.4.1.3.13	ODBC Data Source.....	73
2.4.4.1.3.14	SMOServer Data Source	73
2.4.4.1.3.15	SMTP Data Source	74
2.4.4.1.3.16	SQLMOBILE Data Source	75
2.4.4.1.3.17	WMI Data Source.....	75
2.4.5	ExecutableTypePackagePropertyNameEnum	76
2.4.6	ExecutableTypePackageAttributeGroup	76
2.4.6.1	PackageTypeEnum.....	79
2.4.6.2	ProtectionLevelEnum.....	79
2.4.6.3	PackagePriorityClassEnum	80
2.4.6.4	CheckpointUsageEnum	80
2.4.7	PackageParametersType	81
2.4.7.1	PackageParameterType	81
2.4.7.2	PackageParameterPropertyType	83
2.4.7.3	PackageParameterEncryptedValuePropertyType.....	83
2.5	ExecutablesType.....	84
2.5.1	AnyNonPackageExecutableType	84
2.5.1.1	AnyNonPackageExecutableTypeExecutableTypeEnum	88
2.5.1.1.1	ForEachEnumeratorType	95
2.5.1.1.1.1	ForEachEnumeratorObjectDataType	96
2.5.1.1.1.1.1	FEIEItemsType	98
2.5.1.1.1.1.1.1	FEIEItemType	98
2.5.1.1.1.1.1.1.1	FEIEItemValue Type	99
2.5.1.1.1.1.2	ForEachFileEnumeratorPropertiesType	99
2.5.1.1.1.1.3	FEEADOType	100
2.5.1.1.1.1.3.1	FEEADOEnumType.....	101
2.5.1.1.1.1.4	FEESchemaRowsetType	101
2.5.1.1.1.1.4.1	RestrictionElementType.....	102
2.5.1.1.1.1.5	FEEFVEType	103
2.5.1.1.1.1.6	FEENODELISTType	103
2.5.1.1.1.1.6.1	NodelistEnumerationTypeEnum	104
2.5.1.1.1.1.6.2	NodelistInnerElementEnumerationTypeEnum	105
2.5.1.1.1.1.7	FEESMOType	105
2.5.2	ForEachVariableMappingsType	106
2.5.2.1	ForEachVariableMappingType	106
2.5.2.1.1	ForEachVariableMappingAttributeGroup.....	107
2.5.3	AnyNonPackageExecutableAttributeGroup	108

2.6	ExecutableType Attribute Values for Different Executables	109
2.6.1	ExecutableType Instance for Pipeline	109
2.6.2	Executable Container Types	111
2.6.2.1	ExecutableType Instance for Sequence	111
2.6.2.2	ExecutableType Instance for ForEachLoop	112
2.6.2.3	ExecutableType Instance for ForLoop	113
2.6.3	Executable Task Types	114
2.6.3.1	ExecutableType Instance for ActiveX Script Task	114
2.6.3.1.1	TaskExeAttributeGroup	116
2.6.3.2	ExecutableType Instance for AS Execute DDL Task	116
2.6.3.3	ExecutableType Instance for AS Processing Task	117
2.6.3.4	ExecutableType Instance for Bulk Insert Task	119
2.6.3.5	ExecutableType Instance for Data Mining Query Task	121
2.6.3.6	ExecutableType Instance for Data Profiling Task	122
2.6.3.7	ExecutableType Instance for Execute DTS 2000 Package Task	124
2.6.3.8	ExecutableType Instance for Execute Package Task	125
2.6.3.9	ExecutableType Instance for Execute Process Task	127
2.6.3.10	ExecutableType Instance for Execute SQL Task	128
2.6.3.11	ExecutableType Instance for File System Task	130
2.6.3.12	ExecutableType Instance for FTP Task	132
2.6.3.13	ExecutableType Instance for Message Queue Task	133
2.6.3.14	ExecutableType Instance for Script Task	135
2.6.3.15	ExecutableType Instance for Send Mail Task	136
2.6.3.16	ExecutableType Instance for Transfer Database Task	138
2.6.3.17	ExecutableType Instance for Transfer Error Messages Task	139
2.6.3.18	ExecutableType Instance for Transfer Jobs Task	141
2.6.3.19	ExecutableType Instance for Transfer Logins Task	142
2.6.3.20	ExecutableType Instance for Transfer Stored Procedures Task	144
2.6.3.21	ExecutableType Instance for Transfer SQL Server Objects Task	146
2.6.3.22	ExecutableType Instance for Web Service Task	147
2.6.3.23	ExecutableType Instance for WMI Data Reader Task	149
2.6.3.24	ExecutableType Instance for WMI Event Watcher Task	150
2.6.3.25	ExecutableType Instance for XML Task	152
2.6.4	Executable Maintenance Tasks	153
2.6.4.1	ExecutableType Instance for Backup Task	154
2.6.4.2	ExecutableType Instance for Check Integrity Task	156
2.6.4.3	ExecutableType Instance for Execute SQL Agent Job Task	158
2.6.4.4	ExecutableType Instance for History Cleanup Task	160
2.6.4.5	ExecutableType Instance for Maintenance File Cleanup Task	162
2.6.4.6	ExecutableType Instance for Notify Operator Task	164
2.6.4.7	ExecutableType Instance for Rebuild Index Task	166
2.6.4.8	ExecutableType Instance for Reorganize Index Task	168
2.6.4.9	ExecutableType Instance for Shrink Database Task	170
2.6.4.10	ExecutableType Instance for Update Statistics Task	172
2.6.4.11	ExecutableType Instance for Execute TSQL Task	174
2.7	Executable ObjectData Types	176
2.7.1	ExecutableObjectDataType	176
2.7.1.1	pipelineObjectDataType	177
2.7.1.1.1	PipelineComponentsType	178
2.7.1.1.1.1	PipelineComponentType	179
2.7.1.1.1.1.1	PipelineComponentPropertiesType	181
2.7.1.1.1.1.1.1	PipelineComponentPropertyType	181
2.7.1.1.1.1.1.1.1	PipelineComponentArrayElementsType	182

2.7.1.1.1.1.1.1.1	PipelineComponentArrayType	182
2.7.1.1.1.1.1.1.2	PipelineComponentPropertyNameEnum	183
2.7.1.1.1.1.1.1.2.1	Aggregate Component	187
2.7.1.1.1.1.1.1.2.2	Audit Component	188
2.7.1.1.1.1.1.1.2.3	Cache Transform Component	188
2.7.1.1.1.1.1.1.2.4	Character Map Component	188
2.7.1.1.1.1.1.1.2.5	Conditional Split Component	188
2.7.1.1.1.1.1.1.2.6	Copy Column Component	188
2.7.1.1.1.1.1.1.2.7	Data Conversion Component	188
2.7.1.1.1.1.1.1.2.8	Data Mining Query Component	189
2.7.1.1.1.1.1.1.2.9	Derived Column Component	189
2.7.1.1.1.1.1.1.2.10	Export Column Component	189
2.7.1.1.1.1.1.1.2.11	Fuzzy Grouping Component	189
2.7.1.1.1.1.1.1.2.12	Fuzzy Lookup Component	190
2.7.1.1.1.1.1.1.2.13	Import Column Component	191
2.7.1.1.1.1.1.1.2.14	Lookup Component	191
2.7.1.1.1.1.1.1.2.15	Merge Component	192
2.7.1.1.1.1.1.1.2.16	MergeJoin Component	192
2.7.1.1.1.1.1.1.2.17	Multicast Component	193
2.7.1.1.1.1.1.1.2.18	OLE DB Command Component	193
2.7.1.1.1.1.1.1.2.19	Percentage Sampling Component	193
2.7.1.1.1.1.1.1.2.20	Pivot Component	193
2.7.1.1.1.1.1.1.2.21	RowCount Component	193
2.7.1.1.1.1.1.1.2.22	Row Sampling Component	194
2.7.1.1.1.1.1.1.2.23	Script Component	194
2.7.1.1.1.1.1.1.2.24	Slowly Changing Dimension Component	195
2.7.1.1.1.1.1.1.2.25	Sort Component	196
2.7.1.1.1.1.1.1.2.26	Term Extraction Component	196
2.7.1.1.1.1.1.1.2.27	Term Lookup Component	197
2.7.1.1.1.1.1.1.2.28	Union All Component	197
2.7.1.1.1.1.1.1.2.29	Unpivot Component	198
2.7.1.1.1.1.1.1.2.30	ADO.NET Destination Component	198
2.7.1.1.1.1.1.1.2.31	Excel Destination Component	198
2.7.1.1.1.1.1.1.2.32	Flat File Destination Component	199
2.7.1.1.1.1.1.1.2.33	OLE DB Destination Component	200
2.7.1.1.1.1.1.1.2.34	DataReader Destination Component	201
2.7.1.1.1.1.1.1.2.35	Data Mining Model Training Destination Component	201
2.7.1.1.1.1.1.1.2.36	Dimension Processing Destination Component	202
2.7.1.1.1.1.1.1.2.37	Partition Processing Destination Component	203
2.7.1.1.1.1.1.1.2.38	Raw File Destination Component	205
2.7.1.1.1.1.1.1.2.39	RecordSet Destination Component	206
2.7.1.1.1.1.1.1.2.40	SQL Server Compact Edition Destination Component	206
2.7.1.1.1.1.1.1.2.41	SQL Server Destination Component	207
2.7.1.1.1.1.1.1.2.42	ADO.NET Source Component	208
2.7.1.1.1.1.1.1.2.43	Excel Source Component	209
2.7.1.1.1.1.1.1.2.44	Flat File Source Component	209
2.7.1.1.1.1.1.1.2.45	OLE DB Source Component	210
2.7.1.1.1.1.1.1.2.46	Raw File Source Component	211
2.7.1.1.1.1.1.1.2.47	XML Source Component	211
2.7.1.1.1.1.1.1.3	PipelineComponentDataTypeEnum	212
2.7.1.1.1.1.1.1.4	PipelineComponentStateEnum	213
2.7.1.1.1.1.1.1.5	PipelineComponentExpressionTypeEnum	214
2.7.1.1.1.1.2	PipelineComponentConnectionsType	214

2.7.1.1.1.1.2.1	PipelineComponentConnectionType	215
2.7.1.1.1.1.3	PipelineComponentInputsType	215
2.7.1.1.1.1.3.1	PipelineComponentInputType	216
2.7.1.1.1.1.3.1.1	PipelineComponentInputColumnsType	217
2.7.1.1.1.1.3.1.2	PipelineComponentInputColumnType	217
2.7.1.1.1.1.3.1.3	PipelineComponentInputColumnPropertiesType	219
2.7.1.1.1.1.3.1.3.1	PipelineComponentInputColumnPropertyType	219
2.7.1.1.1.1.3.1.3.1.1	PipelineComponentInputColumnPropertyNameEnum	220
2.7.1.1.1.1.3.1.3.1.1.1	Aggregate Component inputColumn Element	221
2.7.1.1.1.1.3.1.3.1.1.2	Audit Component inputColumn Element	222
2.7.1.1.1.1.3.1.3.1.1.3	Cache Component inputColumn Element	222
2.7.1.1.1.1.3.1.3.1.1.4	Character Map Component inputColumn Element	222
2.7.1.1.1.1.3.1.3.1.1.5	Conditional Split Component inputColumn Element	222
2.7.1.1.1.1.3.1.3.1.1.6	Copy Column Component inputColumn Element	222
2.7.1.1.1.1.3.1.3.1.1.7	Data Conversion Component inputColumn Element	223
2.7.1.1.1.1.3.1.3.1.1.8	Data Mining Query Component inputColumn Element	223
2.7.1.1.1.1.3.1.3.1.1.9	Derived Column Component inputColumn Element	223
2.7.1.1.1.1.3.1.3.1.1.10	Export Column Component inputColumn Element	223
2.7.1.1.1.1.3.1.3.1.1.11	Fuzzy Grouping Component inputColumn Element	224
2.7.1.1.1.1.3.1.3.1.1.12	Fuzzy Lookup Component inputColumn Element	225
2.7.1.1.1.1.3.1.3.1.1.13	Import Column Component inputColumn Element	225
2.7.1.1.1.1.3.1.3.1.1.14	Lookup Component inputColumn Element	226
2.7.1.1.1.1.3.1.3.1.1.15	Merge Component inputColumn Element	226
2.7.1.1.1.1.3.1.3.1.1.16	MergeJoin Component inputColumn Element	226
2.7.1.1.1.1.3.1.3.1.1.17	Multicast Component inputColumn Element	226
2.7.1.1.1.1.3.1.3.1.1.18	OLE DB Command Component inputColumn Element	226
2.7.1.1.1.1.3.1.3.1.1.19	Percentage Sampling Component inputColumn Element	226
2.7.1.1.1.1.3.1.3.1.1.20	Pivot Component inputColumn Element	227
2.7.1.1.1.1.3.1.3.1.1.21	RowCount Component inputColumn Element	227
2.7.1.1.1.1.3.1.3.1.1.22	Row Sampling Component inputColumn Element	227
2.7.1.1.1.1.3.1.3.1.1.23	Script Component inputColumn Element	227
2.7.1.1.1.1.3.1.3.1.1.24	Slowly Changing Dimension Component inputColumn Element	227
2.7.1.1.1.1.3.1.3.1.1.25	Sort Component inputColumn Element	228
2.7.1.1.1.1.3.1.3.1.1.26	Term Extraction Component inputColumn Element	228
2.7.1.1.1.1.3.1.3.1.1.27	Term Lookup Component inputColumn Element	228
2.7.1.1.1.1.3.1.3.1.1.28	Union All Component inputColumn Element	228
2.7.1.1.1.1.3.1.3.1.1.29	Unpivot Component inputColumn Element	229
2.7.1.1.1.1.3.1.3.1.1.30	ADO.NET Destination Component inputColumn Element	229
2.7.1.1.1.1.3.1.3.1.1.31	Excel Destination Component inputColumn Element	229
2.7.1.1.1.1.3.1.3.1.1.32	Flat File Destination Component inputColumn Element	229
2.7.1.1.1.1.3.1.3.1.1.33	OLE DB Destination Component inputColumn Element	229
2.7.1.1.1.1.3.1.3.1.1.34	DataReader Destination Component inputColumn Element	229
2.7.1.1.1.1.3.1.3.1.1.35	Data Mining Model Training Destination Component inputColumn Element	229

2.7.1.1.1.1.3.1.3.1.1.36	Dimension Processing Destination Component inputColumn Element	230
2.7.1.1.1.1.3.1.3.1.1.37	Partition Processing Destination Component inputColumn Element	230
2.7.1.1.1.1.3.1.3.1.1.38	Raw File Destination Component inputColumn Element	230
2.7.1.1.1.1.3.1.3.1.1.39	RecordSet Destination Component inputColumn Element	230
2.7.1.1.1.1.3.1.3.1.1.40	SQL Server Compact Edition Destination Component inputColumn Element	230
2.7.1.1.1.1.3.1.3.1.1.41	SQL Server Destination Component inputColumn Element	230
2.7.1.1.1.1.3.1.3.2	PipelineComponentUsageTypeEnum	230
2.7.1.1.1.1.3.1.4	PipelineComponentInputPropertiesType	231
2.7.1.1.1.1.3.1.5	PipelineComponentInputPropertyType	231
2.7.1.1.1.1.3.1.6	PipelineComponentInputPropertyNameEnum	232
2.7.1.1.1.1.4	PipelineComponentOutputsType	232
2.7.1.1.1.1.4.1	PipelineComponentOutputType	233
2.7.1.1.1.1.4.1.1	PipelineComponentOutputColumnsType	235
2.7.1.1.1.1.4.1.1.1	PipelineComponentOutputColumnType	235
2.7.1.1.1.1.4.1.1.2	PipelineComponentOutputColumnPropertiesType	237
2.7.1.1.1.1.4.1.1.2.1	PipelineComponentOutputColumnPropertyType	237
2.7.1.1.1.1.4.1.1.2.1.1	PipelineComponentOutputColumnPropertyNameEnum	238
2.7.1.1.1.1.4.1.1.2.1.1.1	Aggregate Component outputColumn Element	239
2.7.1.1.1.1.4.1.1.2.1.1.2	Audit Component outputColumn Element	240
2.7.1.1.1.1.4.1.1.2.1.1.3	Cache Transform Component outputColumn Element	241
2.7.1.1.1.1.4.1.1.2.1.1.4	Character Map Component outputColumn Element	241
2.7.1.1.1.1.4.1.1.2.1.1.5	Conditional Split Component outputColumn Element	241
2.7.1.1.1.1.4.1.1.2.1.1.6	Copy Column Component outputColumn Element	241
2.7.1.1.1.1.4.1.1.2.1.1.7	Data Conversion Component outputColumn Element	241
2.7.1.1.1.1.4.1.1.2.1.1.8	Data Mining Query Component outputColumn Element	242
2.7.1.1.1.1.4.1.1.2.1.1.9	Derived Column Component outputColumn Element	242
2.7.1.1.1.1.4.1.1.2.1.1.10	Export Column Component outputColumn Element	242
2.7.1.1.1.1.4.1.1.2.1.1.11	Fuzzy Grouping Component outputColumn Element	242
2.7.1.1.1.1.4.1.1.2.1.1.12	Fuzzy Lookup Component outputColumn Element	243
2.7.1.1.1.1.4.1.1.2.1.1.13	Import Column Component outputColumn Element	243
2.7.1.1.1.1.4.1.1.2.1.1.14	Lookup Component outputColumn Element	243
2.7.1.1.1.1.4.1.1.2.1.1.15	Merge Component outputColumn Element	244
2.7.1.1.1.1.4.1.1.2.1.1.16	MergeJoin Component outputColumn Element	244
2.7.1.1.1.1.4.1.1.2.1.1.17	Multicast Component outputColumn Element	244
2.7.1.1.1.1.4.1.1.2.1.1.18	OLE DB Command Component outputColumn Element	244

2.7.1.1.1.1.4.1.1.2.1.1.19	Percentage Sampling Component outputColumn Element	244
2.7.1.1.1.1.4.1.1.2.1.1.20	Pivot Component outputColumn Element	244
2.7.1.1.1.1.4.1.1.2.1.1.21	RowCount Component outputColumn Element	245
2.7.1.1.1.1.4.1.1.2.1.1.22	Row Sampling Component outputColumn Element	245
2.7.1.1.1.1.4.1.1.2.1.1.23	Script Component outputColumn Element	245
2.7.1.1.1.1.4.1.1.2.1.1.24	Slowly Changing Dimension Component outputColumn Element	245
2.7.1.1.1.1.4.1.1.2.1.1.25	Sort Component outputColumn Element	245
2.7.1.1.1.1.4.1.1.2.1.1.26	Term Extraction Component outputColumn Element	246
2.7.1.1.1.1.4.1.1.2.1.1.27	Term Lookup Component outputColumn Element	246
2.7.1.1.1.1.4.1.1.2.1.1.28	Union All Component outputColumn Element	246
2.7.1.1.1.1.4.1.1.2.1.1.29	Unpivot Component outputColumn Element	246
2.7.1.1.1.1.4.1.1.2.1.1.30	ADO.NET Source Component outputColumn Element	246
2.7.1.1.1.1.4.1.1.2.1.1.31	Excel Source Component outputColumn Element	246
2.7.1.1.1.1.4.1.1.2.1.1.32	Flat File Source Component outputColumn Element	247
2.7.1.1.1.1.4.1.1.2.1.1.33	OLE DB Source Component outputColumn Element	247
2.7.1.1.1.1.4.1.1.2.1.1.34	Raw File Source Component outputColumn Element	247
2.7.1.1.1.1.4.1.1.2.1.1.35	XML Source Component outputColumn Element	247
2.7.1.1.1.1.4.1.2	PipelineComponentOutputPropertiesType	247
2.7.1.1.1.1.4.1.2.1	PipelineComponentOutputPropertyType	248
2.7.1.1.1.1.4.1.2.1.1	PipelineComponentOutputPropertyNameEnum	249
2.7.1.1.1.1.4.1.2.1.1.1	Aggregate Component output Element	250
2.7.1.1.1.1.4.1.2.1.1.2	Audit Component output Element	250
2.7.1.1.1.1.4.1.2.1.1.3	Cache Transform Component output Element	250
2.7.1.1.1.1.4.1.2.1.1.4	Character Map Component output Element	250
2.7.1.1.1.1.4.1.2.1.1.5	Conditional Split Component output Element	250
2.7.1.1.1.1.4.1.2.1.1.6	Copy Column Component output Element	251
2.7.1.1.1.1.4.1.2.1.1.7	Data Conversion Component output Element	251
2.7.1.1.1.1.4.1.2.1.1.8	Data Mining Query Component output Element	251
2.7.1.1.1.1.4.1.2.1.1.9	Derived Column Component output Element	251
2.7.1.1.1.1.4.1.2.1.1.10	Export Column Component output Element	251
2.7.1.1.1.1.4.1.2.1.1.11	Fuzzy Grouping Component output Element	251
2.7.1.1.1.1.4.1.2.1.1.12	Fuzzy Lookup Component output Element	251
2.7.1.1.1.1.4.1.2.1.1.13	Import Column Component output Element	251
2.7.1.1.1.1.4.1.2.1.1.14	Lookup Component output Element	252
2.7.1.1.1.1.4.1.2.1.1.15	Merge Component output Element	252
2.7.1.1.1.1.4.1.2.1.1.16	MergeJoin Component output Element	252
2.7.1.1.1.1.4.1.2.1.1.17	Multicast Component output Element	252
2.7.1.1.1.1.4.1.2.1.1.18	OLE DB Command Component output Element	252
2.7.1.1.1.1.4.1.2.1.1.19	Percentage Sampling Component output Element	252
2.7.1.1.1.1.4.1.2.1.1.20	Pivot Component output Element	252
2.7.1.1.1.1.4.1.2.1.1.21	RowCount Component output Element	252
2.7.1.1.1.1.4.1.2.1.1.22	Row Sampling Component output Element	252
2.7.1.1.1.1.4.1.2.1.1.23	Script Component output Element	253
2.7.1.1.1.1.4.1.2.1.1.24	Slowly Changing Dimension Component output Element	253

2.7.1.1.1.1.4.1.2.1.1.25	Sort Component output Element	253
2.7.1.1.1.1.4.1.2.1.1.26	Term Extraction Component output Element	253
2.7.1.1.1.1.4.1.2.1.1.27	Term Lookup Component output Element	253
2.7.1.1.1.1.4.1.2.1.1.28	Union All Component output Element	253
2.7.1.1.1.1.4.1.2.1.1.29	Unpivot Component output Element	253
2.7.1.1.1.1.4.1.2.1.1.30	ADO.NET Source Component output Element	253
2.7.1.1.1.1.4.1.2.1.1.31	Excel Source Component output Element	253
2.7.1.1.1.1.4.1.2.1.1.32	Flat File Source Component output Element	253
2.7.1.1.1.1.4.1.2.1.1.33	OLE DB Source Component output Element	253
2.7.1.1.1.1.4.1.2.1.1.34	Raw File Source Component output Element	254
2.7.1.1.1.1.4.1.2.1.1.35	XML Source Component output Element	254
2.7.1.1.1.1.4.1.3	PipelineComponentRowDispositionEnum	254
2.7.1.1.1.1.5	PipelineComponentComponentClassIDEnum	254
2.7.1.1.1.1.6	Attribute Groups and Common Types Used by Components	259
2.7.1.1.1.1.6.1	PipelineComponentMetadataColumnsType	259
2.7.1.1.1.1.6.1.1	PipelineComponentMetadataColumnType	259
2.7.1.1.1.1.6.1.1.1	PipelineComponentMetadataColumnPropertiesType	260
2.7.1.1.1.1.6.1.1.1.1	PipelineComponentMetadataColumnPropertyType	261
2.7.1.1.1.1.6.1.1.1.1.1	PipelineComponentMetadataColumnPropertyNameEnum	261
2.7.1.1.1.1.6.1.1.1.1.2	OLE DB Command Component	262
2.7.1.1.1.1.6.1.1.1.1.3	XML Source Component	262
2.7.1.1.1.1.6.2	PipelineComponentInputOutputElementAttributeGroup	263
2.7.1.1.1.1.6.3	PipelineComponentAllColumnBaseAttributeGroup	264
2.7.1.1.1.1.6.4	PipelineComponentIOColumnBaseAttributeGroup	265
2.7.1.1.1.1.6.5	PipelineComponentColumnExtendedAttributeGroup	266
2.7.1.1.1.1.6.5.1	PipelineComponentColumnDataTypeEnum	266
2.7.1.1.1.1.6.6	PipelineComponentPropertyAttributeGroup	268
2.7.1.1.2	PipelinePathsType	269
2.7.1.1.2.1	PipelinePathType	270
2.7.1.2	ActiveXScriptTaskData Element	271
2.7.1.2.1	ActiveXScriptTask Namespace	271
2.7.1.2.1.1	ActiveXScriptTaskData Element	271
2.7.1.2.1.1.1	ActiveXScriptTaskDataType	271
2.7.1.2.1.1.1.1	ScriptingLanguageEnum	272
2.7.1.3	ASDdlDataObjectDataType	272
2.7.1.4	ASProcessingDataObjectDataType	273
2.7.1.5	BulkInsertTaskData Element	273
2.7.1.5.1	BulkInsertTask Namespace	274
2.7.1.5.1.1	BulkInsertTaskData Element	274
2.7.1.5.1.2	BulkInsertTaskDataType	274
2.7.1.5.1.2.1	DataFileTypeEnum	277
2.7.1.5.1.2.2	CodePageType	278
2.7.1.5.1.2.3	BulkInsertTaskTerminatorEnum	278
2.7.1.6	DMQueryTaskDataObjectDataType	279
2.7.1.6.1	DMQueryTaskQueryStringContainerType	281
2.7.1.6.2	DMQueryBuilderSpecificationType	281
2.7.1.7	DataProfilingTaskDataObjectDataType	282
2.7.1.7.1	Data Profiling ProfileInput String Format Definition	283
2.7.1.7.1.1	DataProfile Root Element of the ProfileInput String	283
2.7.1.7.1.1.1	DataSourcesType	284
2.7.1.7.1.1.2	DataProfileInputType	284
2.7.1.7.1.1.2.1	ProfileModeType	285

2.7.1.7.1.1.2.2	ProfileRequest Element	285
2.7.1.7.1.1.2.2.1	ProfileRequestType.....	286
2.7.1.7.1.1.2.2.1.1	Elements That Can Be Substituted for the ProfileRequest Element	286
2.7.1.7.1.1.2.2.1.2	ColumnStatisticsProfileRequest Element	286
2.7.1.7.1.1.2.2.1.2.1	ColumnStatisticsProfileRequestType.....	287
2.7.1.7.1.1.2.2.1.3	ColumnLengthDistributionProfileRequest Element	287
2.7.1.7.1.1.2.2.1.3.1	ColumnLengthDistributionProfileRequestType.....	287
2.7.1.7.1.1.2.2.1.4	ColumnValueDistributionProfileRequest Element.....	288
2.7.1.7.1.1.2.2.1.4.1	ColumnValueDistributionProfileRequestType	288
2.7.1.7.1.1.2.2.1.4.1.1	ValueDistributionOptions	289
2.7.1.7.1.1.2.2.1.5	ColumnNullRatioProfileRequest Element	290
2.7.1.7.1.1.2.2.1.5.1	ColumnNullRatioProfileRequestType	290
2.7.1.7.1.1.2.2.1.6	CandidateKeyProfileRequest Element	290
2.7.1.7.1.1.2.2.1.6.1	CandidateKeyProfileRequestType.....	291
2.7.1.7.1.1.2.2.1.7	FunctionalDependencyProfileRequest Element.....	292
2.7.1.7.1.1.2.2.1.7.1	FunctionalDependencyProfileRequestType.....	292
2.7.1.7.1.1.2.2.1.8	InclusionProfileRequest Element.....	293
2.7.1.7.1.1.2.2.1.8.1	InclusionProfileRequestType	294
2.7.1.7.1.1.2.2.1.9	ColumnPatternProfileRequest Element	296
2.7.1.7.1.1.2.2.1.9.1	ColumnPatternProfileRequestType	296
2.7.1.7.1.1.2.2.1.10	Abstract Base Types Used by Data Profiling Task	297
2.7.1.7.1.1.2.2.1.10.1	ColumnProfileRequestType.....	297
2.7.1.7.1.1.2.2.1.10.2	TableProfileRequestType.....	298
2.7.1.7.1.1.2.2.1.11	Other Types Used by Data Profiling Task	298
2.7.1.7.1.1.2.2.1.11.1	TableQNameType	298
2.7.1.7.1.1.2.2.1.11.2	ColumnParameterCollectionType.....	299
2.7.1.7.1.1.2.2.1.11.2.1	ColumnParameterType	299
2.7.1.7.1.1.2.2.1.11.2.1.1	StringCompareOptionsEnum.....	300
2.7.1.7.1.1.2.2.1.11.3	StrengthThresholdSettingType	301
2.7.1.7.1.1.3	DataProfileOutputType.....	302
2.7.1.7.1.1.3.1	ProfilesType.....	302
2.7.1.8	Exec80PackageTaskData Element	302
2.7.1.8.1	Exec80PackageTask Namespace	303
2.7.1.8.1.1	Exec80PackageTaskData Element	303
2.7.1.8.1.1.1	Exec80PackageTaskType.....	303
2.7.1.8.1.1.1.1	Exec80PackageTaskEnum.....	304
2.7.1.9	ExecutePackageTaskObjectDataType.....	305
2.7.1.10	ExecuteProcessDataObjectDataType.....	306
2.7.1.10.1	WindowStyleEnum	308
2.7.1.11	SqlTaskData Element	309
2.7.1.11.1	SQLTask Namespace.....	309
2.7.1.11.1.1	SqlTaskData Element	309
2.7.1.11.1.1.1	SqlTaskDataType	309
2.7.1.11.1.1.1.1	SqlTaskDatabaseSelectionTypeEnum.....	312
2.7.1.11.1.1.1.2	SqlTaskTimeUnitsTypeEnum	313
2.7.1.11.1.1.1.3	SelectedDatabasesType.....	313
2.7.1.11.1.1.1.4	OperatorNotifyListType.....	314
2.7.1.11.1.1.1.5	SqlTaskParameterBindingType	314
2.7.1.11.1.1.1.5.1	ParameterDirectionEnum.....	315
2.7.1.11.1.1.1.6	BackupDestinationListType	315
2.7.1.11.1.1.1.7	SqlTaskResultBindingType	316
2.7.1.11.1.1.1.8	SqlTaskBaseAttributeGroup.....	316

2.7.1.11.1.1.1.8.1	SqlResultTypeEnum.....	317
2.7.1.11.1.1.1.9	MaintenanceTaskBaseAttributeGroup	318
2.7.1.11.1.1.1.10	BackupTaskAttributeGroup.....	319
2.7.1.11.1.1.1.10.1	BackupActionEnum	322
2.7.1.11.1.1.1.10.2	BackupDeviceTypeEnum.....	322
2.7.1.11.1.1.1.10.3	DestinationTypeEnum	323
2.7.1.11.1.1.1.10.4	BackupActionForExistingBackupsEnum	323
2.7.1.11.1.1.1.10.5	BackupCompressionActionEnum	324
2.7.1.11.1.1.1.11	CheckIntegrityTaskAttributeGroup	324
2.7.1.11.1.1.1.12	AgentJobTaskAttributeGroup	325
2.7.1.11.1.1.1.13	HistoryCleanupTaskAttributeGroup.....	326
2.7.1.11.1.1.1.14	MaintenanceFileCleanupTaskAttributeGroup	327
2.7.1.11.1.1.1.14.1	SqlTaskFileTypeSelectedEnum	328
2.7.1.11.1.1.1.15	NotifyOperatorTaskAttributeGroup	329
2.7.1.11.1.1.1.16	RebuildIndexTaskAttributeGroup.....	329
2.7.1.11.1.1.1.17	ReorganizeIndexTaskAttributeGroup	331
2.7.1.11.1.1.1.18	ShrinkDBTaskAttributeGroup	331
2.7.1.11.1.1.1.19	UpdateStatisticsTaskAttributeGroup	332
2.7.1.11.1.1.1.19.1	SqlTaskUpdateStatisticsTypeEnum.....	333
2.7.1.11.1.1.1.19.2	SqlTaskUpdateStatisticsTypeEnum.....	333
2.7.1.11.1.1.1.20	Execute TSQL Task	334
2.7.1.12	FileSystemDataObjectDataType	334
2.7.1.12.1	FileSystemTaskOperationTypeEnum.....	336
2.7.1.12.2	FileSystemTaskFileAttributesEnum.....	336
2.7.1.13	FtpDataObjectDataType.....	337
2.7.1.13.1	FtpDataTaskOperationTypeEnum.....	339
2.7.1.14	MessageQueueTaskData Element.....	340
2.7.1.14.1	MessageQueueTask Namespace	340
2.7.1.14.1.1	MessageQueueTaskData Element.....	340
2.7.1.14.1.1.1	MessageQueueTaskType	341
2.7.1.14.1.1.1.1	MSMQStringCompareTypeEnum	344
2.7.1.14.1.1.1.2	MSMQTaskTypeEnum	345
2.7.1.14.1.1.1.3	MSMQMessageTypeEnum.....	345
2.7.1.14.1.1.1.4	MSMQEncryptionAlgorithmEnum	346
2.7.1.15	ScriptProjectObjectDataType	346
2.7.1.15.1	ScriptProjectProjectItemType.....	347
2.7.1.15.2	ScriptProjectBinaryItemType.....	348
2.7.1.15.3	ScriptProjectBreakpointType	348
2.7.1.15.4	ScriptProjectLanguageEnum	350
2.7.1.15.5	ScriptProjectHitCountTypeEnum	350
2.7.1.15.6	ScriptProjectConditionTypeEnum	351
2.7.1.16	SendMailTaskData Element	351
2.7.1.16.1	SendMailTask Namespace.....	351
2.7.1.16.1.1	SendMailTaskData Element	351
2.7.1.16.1.1.1	SendMailTaskType	352
2.7.1.16.1.1.1.1	AttachmentsElementType	353
2.7.1.16.1.1.1.2	SendMailPriorityEnum	353
2.7.1.17	TransferDatabaseTaskDataObjectDataType	354
2.7.1.17.1	TransferDatabaseTaskActionEnum	355
2.7.1.17.2	TransferDatabaseTaskMethodEnumType.....	356
2.7.1.18	TransferErrorMessagesTaskDataObjectDataType	356
2.7.1.19	TransferJobsTaskDataObjectDataType	357
2.7.1.20	TransferLoginsTaskDataObjectDataType	358

2.7.1.20.1	TransferLoginsTaskLoginsToTransferEnum	359
2.7.1.21	TransferStoredProceduresTaskDataObjectType.....	360
2.7.1.22	TransferSqlServerObjectsTaskDataObjectType	361
2.7.1.22.1	TransferSqlServerObjectsTaskExistingDataEnum	368
2.7.1.23	WebServiceTaskData	368
2.7.1.23.1	WebServiceTask Namespace	369
2.7.1.23.1.1	WebServiceTaskData.....	369
2.7.1.23.1.1.1	WebServiceTaskDataType	369
2.7.1.23.1.1.1.1	WebServiceTaskDataMethodInfoType	370
2.7.1.23.1.1.1.2	WebServiceTaskDataParamInfoType	371
2.7.1.23.1.1.1.3	WebServiceTaskDataOutputTypeEnum	372
2.7.1.24	WMIDRTaskDataObjectType	372
2.7.1.24.1	WMITaskDataOverwriteDestinationEnum	373
2.7.1.24.2	WMITaskDataOutputTypeEnum	374
2.7.1.25	WMIEWTaskDataObjectType	374
2.7.1.25.1	WMIEWTaskDataActionAtEventEnum	376
2.7.1.25.2	WMIEWTaskDataAfterEventEnum	376
2.7.1.25.3	WMIEWTaskDataActionAtTimeoutEnum	376
2.7.1.26	XMLTaskDataObjectType.....	377
2.7.1.26.1	XMLTaskOperationTypeEnum	380
2.7.1.26.2	XMLTaskDiffOptionsType	381
2.7.1.26.3	XMLTaskDiffAlorithmEnum	382
2.7.1.26.4	XMLTaskXPathOperationEnum.....	382
2.7.1.26.5	XMLTaskValidationTypeEnum	383
2.8	Other Types for Package and Non-Package Executables.....	383
2.8.1	PropertyElementBaseType	383
2.8.1.1	DtsDataTypeEnum	384
2.8.2	PropertyExpressionElementType.....	386
2.8.3	LoggingOptionsType	386
2.8.3.1	LoggingOptionsPropertyElementType	388
2.8.3.1.1	LoggingOptionsPropertyNameEnum	389
2.8.3.1.1.1	Property Name=ColumnFilter	389
2.8.3.2	SelectedLogProvidersType	390
2.8.3.2.1	SelectedLogProviderType	391
2.8.3.3	LoggingOptionsAttributeGroup.....	391
2.8.3.3.1	LoggingModeEnum	392
2.8.3.3.2	FilterKindEnum	392
2.8.4	VariablesType	392
2.8.4.1	VariableType	393
2.8.4.1.1	VariableAttributeGroup	394
2.8.4.1.1.1	IncludeInDebugDumpEnum	395
2.8.5	EventHandlersType.....	396
2.8.5.1	EventHandlerType	396
2.8.5.1.1	EventHandlerAttributeGroup	398
2.8.5.1.1.1	EventNameEnum	398
2.8.6	PrecedenceConstraintsType	399
2.8.6.1	PrecedenceConstraintType	400
2.8.6.1.1	PrecedenceConstraintAttributeGroup	401
2.8.6.1.1.1	PrecedenceConstraintEvalOpEnum	402
2.8.6.1.1.2	PrecedenceConstraintValueEnum	402
2.9	Enumeration Types and Supporting Types	403
2.9.1	BasePropertyAttributeGroup	403
2.9.2	BaseExecutablePropertyAttributeGroup	404

2.9.2.1	ISOLevelEnum	405
2.9.2.2	TransactionOptionEnum	406
2.9.2.3	ForceExecutionResultEnum	406
2.9.3	AllExecutableAttributeGroup	407
2.9.4	BooleanStringCap	407
2.9.5	UUID	408
2.9.6	PasswordElementType	408
2.9.7	SourceTypeEnum	409
2.9.8	DestinationTypeEnum	409
2.9.9	IfObjectExistsEnum	410
2.9.10	InnerObjectObjectDataType	410
2.9.11	DesignTimeProperties String Value XML Content	411
2.9.11.1	Objects Element	411
2.9.11.1.1	ObjectsType	411
2.9.11.1.1.1	DesignTimePropertiesContainerType	412
2.9.11.1.1.1.1	LayoutInfoType	412
2.9.11.1.1.1.1.1	is-ser Namespace	413
2.9.11.1.1.1.1.2	is-ser:GraphLayout Element	413
2.9.11.1.1.1.1.3	GraphLayoutType	413
2.9.11.1.1.1.1.3.1	NodeLayoutType	414
2.9.11.1.1.1.1.3.2	EdgeLayoutType	414
2.9.11.1.1.1.1.3.3	EdgeLayoutCurveType	415
2.9.11.1.1.1.1.3.4	mssgle Namespace	416
2.9.11.1.1.1.1.3.5	mssgle:Curve Element	416
2.9.11.1.1.1.1.3.6	CurveType	416
2.9.11.1.1.1.1.3.7	CurveSegmentsType	417
2.9.11.1.1.1.1.3.8	SegmentCollectionType	417
2.9.11.1.1.1.1.3.9	LineSegmentType	418
2.9.11.1.1.1.1.3.10	CubicBezierSegmentType	418
2.9.11.1.1.1.1.3.11	EdgeLayoutLabelsType	419
2.9.11.1.1.1.1.3.12	EdgeLabelCollectionType	419
2.9.11.1.1.1.1.3.13	mssgm Namespace	420
2.9.11.1.1.1.1.3.14	mssgm:EdgeLabel Element	420
2.9.11.1.1.1.1.3.15	EdgeLabelType	420
2.9.11.1.1.1.1.3.16	RelativePositionEnum	421
2.9.11.1.1.1.1.3.17	ContainerLayoutType	421
2.9.11.1.1.1.1.3.18	AnnotationLayoutType	422
2.9.11.1.1.1.1.3.19	AnnotationLayoutFontInfoType	423
2.9.11.1.1.1.1.3.20	mssge Namespace	423
2.9.11.1.1.1.1.3.21	mssge:FontInfo Element	423
2.9.11.1.1.1.1.3.22	FontInfoType	423
2.9.11.1.1.1.1.3.23	FontInfoTextDecorationsType	424
2.9.11.1.1.1.1.3.24	av Namespace	425
2.9.11.1.1.1.1.3.25	av:TextDecorationsCollection Element	425
2.9.11.1.1.1.1.3.26	TextDecorationCollectionType	425
2.9.11.1.1.1.1.3.27	TextDecorationType	425
2.10	Custom Packages	426
2.10.1	Custom Executable	426
2.10.1.1	AnyNonPackageExecutableTypeExecutableTypeEnum Type Replacement	426
2.10.1.2	ExecutableObjectDataType Type Replacement	427
2.10.2	Custom ConnectionManager	427
2.10.2.1	ConnectionManagerObjectDataType Type Replacement	428
2.10.3	Custom Log Provider	428

2.10.4	Custom ForEachEnumerator.....	428
2.10.4.1	ForEachEnumeratorObjectDataType Type Replacement	428
2.10.5	Custom Component	429
2.10.5.1	PipelineComponentComponentClassIDEnum Type Replacement	429
2.10.5.2	PipelineComponentPropertyNameEnum Type Replacement.....	429
2.10.5.3	PipelineComponentInputPropertyNameEnum Type Replacement	430
2.10.5.4	PipelineComponentOutputPropertyNameEnum Type Replacement	430
2.10.5.5	PipelineComponentInputColumnPropertyNameEnum Type Replacement.....	431
2.10.5.6	PipelineComponentOutputColumnPropertyNameEnum Type Replacement	431
3	Structure Examples	432
3.1	Example of Lookup and Fuzzy Lookup Components with Error Output.....	432
3.2	Example of Web Service Task and Script Task	456
3.3	Example of Custom Executable.....	474
3.4	Example of Custom Component	476
4	Security.....	498
4.1	Security Considerations for Implementers.....	498
4.1.1	Encryption Implementation for Settings in the ProtectionLevel Property	498
4.1.1.1	Encryption with User Key.....	498
4.1.1.2	Encryption with Password	498
4.2	Index of Security Fields	498
5	Appendix A: Full DTSX XSD.....	500
5.1	DTS XSD	500
5.2	WebServiceTask XSD	565
5.3	MessageQueueTask XSD.....	566
5.4	SendMailTask XSD	569
5.5	ActiveXScriptTask XSD	570
5.6	Exec80PackageTask XSD	570
5.7	BulkInsertTask XSD	571
5.8	SQLTask XSD	573
6	Appendix B: Product Behavior	585
7	Change Tracking.....	593
8	Index	594

1 Introduction

The Data Transformation Services Package File Format (DTSX) is an XML-based file format that stores the instructions for the processing of a data flow from its points of origin to its points of destination, including transformations and optional processing steps between the origin and destination points.

1.1 Glossary

The following terms are defined in [\[MS-GLOS\]](#):

globally unique identifier (GUID)
language code identifier (LCID)
Simple Mail Transfer Protocol (SMTP)
universally unique identifier (UUID)
Windows Management Instrumentation (WMI)

The following terms are specific to this document:

ActiveX Script Task: A task that executes code written as an ActiveX script.

ADO.NET Destination Component: A component that loads data into an ADO.NET-compliant database.

ADO.NET Source Component: A component that accepts data from an ADO.NET-compliant database as its source of data.

Aggregate Component: A component that aggregates values using functions such as sum and average.

Analysis Services (AS) Execute Data Definition Language (DDL) Task: A task that executes Analysis Services DDL language. AS DDL language is used to create, modify, and manage server objects on an Analysis Services server.

AS Processing Task: A task that is used to initiate the processing of Analysis Services objects by an Analysis Services server.

Audit Component: A component that allows information about the runtime environment of the package to be inserted into the data flow.

Backup Task: A task that is used to add a backup task to a database maintenance plan.

bcp utility: A SQL Server utility that bulk copies data in a user-specified format between an instance of SQL Server and a data file. The bcp utility can be used to import large numbers of new rows into SQL Server tables or to export data out of tables into data files.

BSTR: A binary structure that contains a string. The structure consists of a length prefix, a character string, and a terminator character.

Bulk Insert Task: A task that executes the SQL Server bulk insert statement.

Cache Component: A component that copies its inputs to a cache for fast processing.

Cache Transform Component: A component that copies its inputs to a cache for fast processing.

candidate key profile: An option of the **Data Profiling Task**, which reports whether a column or set of columns is a key, or an approximate key, for a specified table.

Character Map Component: A component that processes character strings by applying string functions to the strings, such as converting case and byte order.

Check Integrity Task: A task that checks the allocation and structural integrity of all the objects in a database.

column length distribution profile: An option of the **Data Profiling Task** that reports all the distinct lengths of string values in the selected column and the percentage of rows in the table that each length represents.

column null ratio distribution profile: An option of the **Data Profiling Task** that reports the percentage of null values in the selected column.

column pattern profile: An option of the **Data Profiling Task** that reports a set of regular expressions that cover the specified percentage of values in a string column.

column statistics profile: A profile that reports statistics about numeric or date/time columns of a database.

column value distribution profile: An option of the **Data Profiling Task** that reports all the distinct values in the selected column and the percentage of rows in the table that each value represents.

Conditional Split Component: A component that splits its input into several outputs, based on conditional logic to determine which output to use for each input row.

Copy Column Component: A component that produces a copy of a column on its output.

Data Conversion Component: A component that converts the data type of a column to a different data type.

Data Mining Model Training Destination Component: A component that applies data mining model training algorithms to the data that it receives from the data flow.

Data Mining Query Component: A component that runs data mining prediction queries.

Data Mining Query Task: A task that runs data mining prediction queries based on data mining models that are built in Analysis Services. The prediction query creates a prediction for new data by using mining models.

Data Profiling Task: A task that computes profiles of data that helps the user understand the values that are present in data and their distribution.

Data Transformation Services (DTS) 2000 Package: A package file in the format of SQL Server 2000. The DTS 2000 Package can execute such packages in Integration Services.

DataReader Destination Component: A component that exposes the data in a data flow by using the ADO.NET DataReader interface. The data can then be consumed by other applications.

Derived Column Component: A component that produces new columns by computing them from an expression.

Dimension Processing Destination Component: A component that loads and processes an Analysis Services dimension.

Excel Destination Component: A component that writes data to a Office Excel workbook.

Excel Source Component: A component that accepts data from an Office Excel workbook as its source of data.

Executable: A unit of executable code that performs a defined task along the data flow in a package.

Execute DTS 2000 Package Task: A task that executes a package from SQL Server 2000.

Execute Package Task: A task that executes a package that is stored independently of the package that is currently executing, such as in a file or in a database.

Execute Process Task: A task that runs an application or batch file as part of a package workflow.

Execute SQL Agent Job Task: A task that runs SQL Server Agent jobs. SQL Server Agent is a Windows service that runs jobs that have been defined in an instance of SQL Server.

Execute SQL Task: A task that runs SQL statements or stored procedures from a package.

Execute TSQL Task: A task that runs T-SQL language statements from a package.

Export Column Component: A component that takes data from the data flow and inserts it into files.

File System Task: A task that performs operations on files and directories in the file system.

Flat File Destination Component: A component that writes data to a flat file.

Flat File Source Component: A component that accepts data from a flat file as its source of data.

ForEach executable: An executable that defines a repeating control flow in a package. The loop implementation is similar to a ForEach looping structure in programming languages.

ForLoop executable: An executable that defines a repeating control flow in a package. The loop implementation is similar to a For looping structure in programming languages.

FTP Task: A task that uses FTP calls to access, download, upload, and manage files on remote servers.

functional dependency profile: An option of the **Data Profiling Task** that reports the extent to which the values in one column (the dependent column) depend on the values in another column or set of columns (the determinant column).

Fuzzy Grouping Component: A component that identifies rows of data that are similar enough to be grouped, if the grouping criteria is considered to be fuzzy and not exact.

Fuzzy Lookup Component: A component that looks up values in a table and matches based on similarity, and therefore does not require an exact match. The match is considered to have been made based on fuzzy criteria.

History Cleanup Task: A task that deletes history entries from a database.

Import Column Component: A component that reads data from a file and inserts it into a data flow.

indirect method: A method by which a configuration file is identified by having a Windows environment variable contain the path to the configuration file, instead of storing the path to the file within the package file itself.

inferred member: A member of an Analysis Services dimension whose existence can be inferred from a fact table but which has not yet been loaded from the dimension.

INI file: Configuration file used by Windows programs to initialize program settings.

inner variable: A DTS 2000 variable that is of package scope to a **DTS 2000 Package** when that package is executed by a parent Integration Services package. The inner variable is passed in to the DTS 2000 package from a parent Integration Services package.

Lookup Component: A component that looks up values in a table and matches the values to data, based on exact matches only.

Maintenance File Cleanup Task: A task that removes database maintenance files according to user-specified logic.

Merge Component: A component that merges two sorted datasets into one output based on values in key columns.

MergeJoin Component: A component that merges two sorted tables, using a FULL, LEFT, or INNER join.

Message Queue Task: A task that access data in **Microsoft Message queuing (MSMQ)**.

Microsoft Message queuing (MSMQ): A communications service that is part of Windows that provides asynchronous and reliable message passing between distributed applications.

Multicast Component: A component that duplicates the input onto all of its outputs.

Notify Operator Task: A task that sends notification messages to an electronic list of SQL Server operators.

OLE DB Command Component: A component that runs an SQL statement for every row in its data flow.

OLE DB Destination Component: A component that loads data into an OLE DB-compliant database.

OLE DB Source Component: A component that accepts data from an OLE DB-compliant database as its source of data.

outer variable: An Integration Services package-scope variable that is passed in to a DTS 2000 package. Inside the DTS 2000 package, it becomes an **inner variable**.

package file: A file that contains a collection of tasks that form a workflow that is executed in the order that is defined within the package, with possible conditional branching.

package parameter: One of the objects within the package. Different values for each parameter can be specified for execution of the package. The value of a parameter can be read by other objects in the package as the package is executing.

package variable: A special type of variable within a package file that contains information about the last state of the screen layout of the package. Package variables are used by the user interface when a new session to modify a package is started.

Partition Processing Destination Component: A component that loads and processes an Analysis Services partition.

passive mode: An FTP mode in which the client initiates a conversation by connection to the FTP server port, and the client also initiates the data communication port connection, to a port specified by the server in its initial response to the client. For more information about FTP active mode and passive mode, see [\[KB323446\]](#).

Percentage Sampling Component: A component that creates a sample data set by randomly selecting a percentage of the transformation input rows.

Pipeline Task: An executable that maps a data flow from an origin to a destination, with passing the data flow through a series of components.

Pivot Component: A component that makes a normalized data set into a less normalized but more compact version by pivoting the input data on a column value.

precedence constraint: An object in an Integration Services package that controls the order of execution of tasks or the condition under which a task executes.

Raw File Destination Component: A component that writes raw data to a file in a format that is native to the file type.

Raw File Source Component: A component that accepts data from a raw file as its source of data.

Rebuild Index Task: A task that rebuilds indexes in database tables and views.

RecordSet Destination Component: A component that creates and populates an in-memory ADO recordset.

Reorganize Index Task: A task that defragments an index in a database table or view.

Row Sampling Component: A component that is used to extract a randomly selected subset of the input data.

RowCount Component: A component that counts rows in the data flow and stores the result in a variable.

Script Component: A component that runs custom code that is created in a programming environment within the data flow.

Script Task: A task that runs custom code that is created in a programming environment within the data flow.

Send Mail Task: A task that sends e-mail messages.

Sequence executable: A task that serves as a container for other tasks, which are executed in a defined sequence.

Server Management Objects (SMO) Server: An instance of SQL Server that is accessed through calls to the Server Management Objects (SMO) object model.

Shrink Database Task: A task that removes unused space from within database files.

Slowly Changing Dimension Component: A component that configures the updating of a slowly changing dimension.

Sort Component: A component that sorts data.

SQL Server Compact Edition Destination Component: A component that loads data into a SQL Server Compact Edition database.

SQL Server Destination Component: A component that connects to a local SQL Server database and bulk loads data into SQL Server tables and views on a server that is local to where the package is executing.

tag table: A table that is used in the column pattern profile option of the **Data Profiling Component**. This table contains a list of tags that are used to tag specific terms that are found in the data file.

task: The building block of a package. A task consists of code that executes a function, as specified by the options, settings, and parameters of the task that are specified when the task is called.

Term Extraction Component: A component that extracts words from text, based on grammatical rules (English language only) to normalize the words.

Term Lookup Component: A component that looks for a specified set of terms among terms that are extracted using the same methodology that the **Term Extraction Component** uses.

TFIDF Score: One of the options for producing a similarity score used by the term extraction component. The TFIDF score is defined as: $TFIDF \text{ of a Term } T = (\text{frequency of } T) * \log(\# \text{rows in Input} / (\# \text{rows having } T))$

Transfer Database Task: A task that copies or moves a database between different instances of the database server.

Transfer Error Messages Task: A task that transfers user-defined error messages between instances of a database.

Transfer Jobs Task: A task that transfers SQL Server Agent Jobs between instances of a SQL Server database.

Transfer Logins Task: A task that transfers user logins between instances of a database.

Transfer SQL Server Objects Task: A task that transfers objects between instances of SQL Server.

Transfer Stored Procedures Task: A task that transfers stored procedures between database instances.

Union All Component: A component that combines multiple inputs into one output stream.

Unpivot Component: A component that makes an unnormalized dataset into a more normalized version by expanding values from multiple columns in a single record into multiple records with the same values in a single column.

Update Statistics Task: A task that updates the statistics about key columns that are stored in a database.

value inclusion profile: An option of the **Data Profiling Task** that computes the overlap in the values between two columns or sets of columns. Thus, the value inclusion profile can also determine whether a column or set of columns is appropriate to serve as a foreign key between the selected tables.

variable: One of the objects within a package file. A variable allows a package designer to assign a value to a symbolic name, which can then be accessed by other package objects.

Web Service Task: A task that executes a call to a Web service method.

WMI Data Reader Task: A task that runs queries using the WMI Query Language (WQL) that returns information from **WMI** about a computer system.

WMI Event Watcher Task: A task that watches for a **WMI** event using a WMI Query Language (WQL) event query to specify events of interest.

WPF unit: A device-independent unit measure that will render at the same physical size on all devices.

XML Source Component: A component that accepts data from an XML file as its source of data.

XML Task: A task that is used to work with XML data. Using this task, a package can retrieve XML documents; apply operations to the documents by using Extensible Stylesheet Language Transformations (XSLT) style sheets and XPath expressions; merge multiple documents; or validate, compare, and save the updated documents to files and variables.

XPathNavigator: An object that allows navigation of the set of objects that are returned by an XPath query.

MAY, SHOULD, MUST, SHOULD NOT, MUST NOT: These terms (in all caps) are used as described in [\[RFC2119\]](#). All statements of optional behavior use either MAY, SHOULD, or SHOULD NOT.

1.2 References

References to Microsoft Open Specification documents do not include a publishing year because links are to the latest version of the documents, which are updated frequently. References to other documents include a publishing year when one is available.

1.2.1 Normative References

We conduct frequent surveys of the normative references to assure their continued availability. If you have any issue with finding a normative reference, please contact dochelp@microsoft.com. We will assist you in finding the relevant information. Please check the archive site, <http://msdn2.microsoft.com/en-us/library/E4BD6494-06AD-4aed-9823-445E921C9624>, as an additional source.

[ISO/IEC-8859-1] International Organization for Standardization, "Information Technology -- 8-Bit Single-Byte Coded Graphic Character Sets -- Part 1: Latin Alphabet No. 1", ISO/IEC 8859-1, 1998, <http://www.iso.org/iso/en/CatalogueDetailPage.CatalogueDetail?CSNUMBER=28245&ICS1=35&ICS2=40&ICS3=>

Note There is a charge to download the specification.

[RFC2119] Bradner, S., "Key words for use in RFCs to Indicate Requirement Levels", BCP 14, RFC 2119, March 1997, <http://www.ietf.org/rfc/rfc2119.txt>

[RFC2459] Housley, R., Ford, W., Polk, W., and Solo, D., "Internet X.509 Public Key Infrastructure Certificate and CRL Profile", RFC 2459, January 1999, <http://www.ietf.org/rfc/rfc2459.txt>

[UNICODE] The Unicode Consortium, "Unicode Home Page", 2006, <http://www.unicode.org/>

[US-ASCII] Columbia University, "The US ASCII Character Set", 1986,
<http://www.columbia.edu/kermit/ascii.html>

[XML10] World Wide Web Consortium, "Extensible Markup Language (XML) 1.0 (Third Edition)",
February 2004, <http://www.w3.org/TR/REC-xml>

[XMLEncryptSyntax] Dillaway, B., Imamura, T., Simon, E., "XML Encryption Syntax and Processing",
W3C Recommendation, December 2002, <http://www.w3.org/TR/xmlenc-core/>

[XMLNS] World Wide Web Consortium, "Namespaces in XML 1.0 (Second Edition)", August 2006,
<http://www.w3.org/TR/2006/REC-xml-names-20060816/>

[XMLSCHEMA1] Thompson, H.S., Ed., Beech, D., Ed., Maloney, M., Ed., and Mendelsohn, N., Ed.,
"XML Schema Part 1: Structures", W3C Recommendation, May 2001,
<http://www.w3.org/TR/2001/REC-xmlschema-1-20010502/>

[XMLSCHEMA2] Biron, P.V., Ed. and Malhotra, A., Ed., "XML Schema Part 2: Datatypes", W3C
Recommendation, May 2001, <http://www.w3.org/TR/2001/REC-xmlschema-2-20010502/>

1.2.2 Informative References

[ECMA-327] ECMA international, "ECMAScript Compact Profile", 3rd Edition, Standard ECMA-327,
June 2001, <http://www.ecma-international.org/publications/standards/Ecma-327.htm>

[Haselden] Haselden, K. "Microsoft SQL Server 2005 Integration Services", Sams, 2006 ISBN:
0672327813.

[JavaSpec] Sun Microsystems, "The Java Language Specification", 3rd Edition, January 2005,
http://java.sun.com/docs/books/jls/third_edition/html/j3TOC.html

[KB323446] Microsoft Corporation, "How to configure Internet Explorer to use both the FTP PORT
mode and the FTP PASV mode in the Windows Server 2003 Family",
<http://support.microsoft.com/kb/323446>

[MS-GLOS] Microsoft Corporation, "[Windows Protocols Master Glossary](#)".

[MSDN-ADONETSRC] Microsoft Corporation, "ADO NET Source", <http://msdn.microsoft.com/en-us/library/ms137897.aspx>

[MSDN-BCPU] Microsoft Corporation, "bcp Utility", [http://msdn.microsoft.com/en-us/library/ms162802\(SQL.105\).aspx](http://msdn.microsoft.com/en-us/library/ms162802(SQL.105).aspx)

[MSDN-C#LS] Microsoft Corporation, "C# Language Specification", <http://msdn.microsoft.com/en-us/library/ms228593.aspx>

[MSDN-CryptProtectData] Microsoft Corporation, "CryptProtectData Function",
[http://msdn.microsoft.com/en-us/library/aa380261\(VS.85\).aspx](http://msdn.microsoft.com/en-us/library/aa380261(VS.85).aspx)

[MSDN-DMXR] Microsoft Corporation, "Data Mining Extensions (DMX) Reference",
<http://msdn.microsoft.com/en-us/library/ms132058.aspx>

[MSDN-EPCO] Microsoft Corporation, "Extending Packages with Custom Objects",
[http://msdn.microsoft.com/en-us/library/ms345161\(v=SQL.100\).aspx](http://msdn.microsoft.com/en-us/library/ms345161(v=SQL.100).aspx)

[MSDN-MMASDM] Microsoft Corporation, "Mining Models (Analysis Services - Data Mining)",
<http://msdn.microsoft.com/en-us/library/cc645779.aspx>

[MSDN-MSASDM] Microsoft Corporation, "Mining Structures (Analysis Services - Data Mining)", <http://msdn.microsoft.com/en-us/library/ms174757.aspx>

[MSDN-PBCO] Microsoft Corporation, "Performing Bulk Copy Operations", <http://msdn.microsoft.com/en-us/library/ms130809.aspx>

[MSDN-POS] Microsoft Corporation, "Processing Options and Settings", [http://msdn.microsoft.com/en-us/library/ms174774\(SQL.90\).aspx](http://msdn.microsoft.com/en-us/library/ms174774(SQL.90).aspx)

[MSDN-TYPCLS] Microsoft Corporation, "Type Class", [http://msdn.microsoft.com/en-us/library/system.type\(v=VS.80\).aspx](http://msdn.microsoft.com/en-us/library/system.type(v=VS.80).aspx)

[MSDN-VBSLR] Microsoft Corporation, "VBScript Language Reference", [http://msdn.microsoft.com/en-us/library/d1wf56tt\(VS.85\).aspx](http://msdn.microsoft.com/en-us/library/d1wf56tt(VS.85).aspx)

[MSDN-VBLR] Microsoft Corporation, "Visual Basic Language Reference", <http://msdn.microsoft.com/en-us/library/sh9ywfdk.aspx>

[RFC2268] Rivest, R., "A Description of the RC2(r) Encryption Algorithm", RFC 2268, March 1998, <http://www.ietf.org/rfc/rfc2268.txt>

[SCAN-RC4] Rivest, R. "RC4 Stream Cipher", September 2004, <http://www.users.zetnet.co.uk/hopwood/crypto/scan/cs.html#RC4>

1.3 Overview

This document describes the persistence file structure for Microsoft® SQL Server® Integration Services (SSIS). Integration Services is used to orchestrate activities to move and conform data from disparate sources in an enterprise into a convenient location and shape, often for analysis and reporting. The DTSX structure describes these orchestration activities as a pathway that is comprised of a set of steps, each of which can involve processing of the data as it flows through the step. Steps can be conditional or iterative, and not all of the steps that are described in this document are necessarily executed on any one passing of data through the defined steps.

The set of steps starts with a reference to a source from which to import data to begin the set of operations that the data will be passed through. The DTSX structure then allows the user to specify that the data is to pass through an executable that performs a processing **task** upon the data, or that the data is to pass through a pipeline **component** that modifies and/or transforms the data. The structure also allows the ability to define a pathway for the data with conditional elements that can change the data flow pathways or operate iteratively in a loop.

Finally, the structure allows the ability to define a final destination for the post-processed data flow. A file that conforms to the DTSX structure as defined in this document can then be processed by the data transformation processing engine, or it can be opened in a user interface to make modifications to the definition.

The following diagram shows one typical use of Integration Services: to consolidate a data flow from multiple sources, and while consolidating, also transform and assure consistency of all the data.

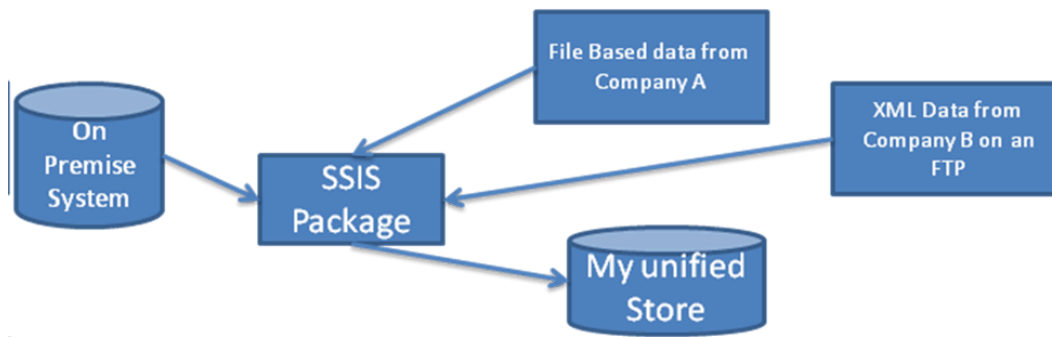

Figure 1: Integration Services package data flow

The intermediate step in the data flow can be one of the following:

- **Executable Task:** Performs a defined type of work along the data flow. Custom tasks can be written by end users to perform any task that is not included with the Integration Services product. Examples of standard tasks that ship with Integration Services are tasks that manipulate an external file, process Microsoft® SQL Server® Analysis Services objects, run a data mining query, perform file transfers with FTP, perform a database backup, and execute an external executable.
- **Component:** Components perform data transformations along the data flow. Examples of components that ship with Integration Services are components that perform aggregation; create columns derived by a specified formula; and perform row counts, sampling, lookups, and many other tasks. End users can also create custom components to perform additional transformations that are not included with the standard product.

The following diagram is a detailed example of a data flow described by the DTSX structure format. The diagram shows the presence of two data sources (an OLE DB Source and a Flat File Source) and three final data destinations (a Raw File Destination, an OLE DB destination, and a SQL Server Destination). The steps in the data flow, based on conditional processing, determine which destination the data ultimately flows to and how it is transformed and processed on the route to its final destination.

Some of the intermediate steps are conditional. For example, in the diagram there are two arrows between Lookup and Fuzzy Lookup. One arrow represents the data flow for erroneous data, and the other represents the flow for standard output.

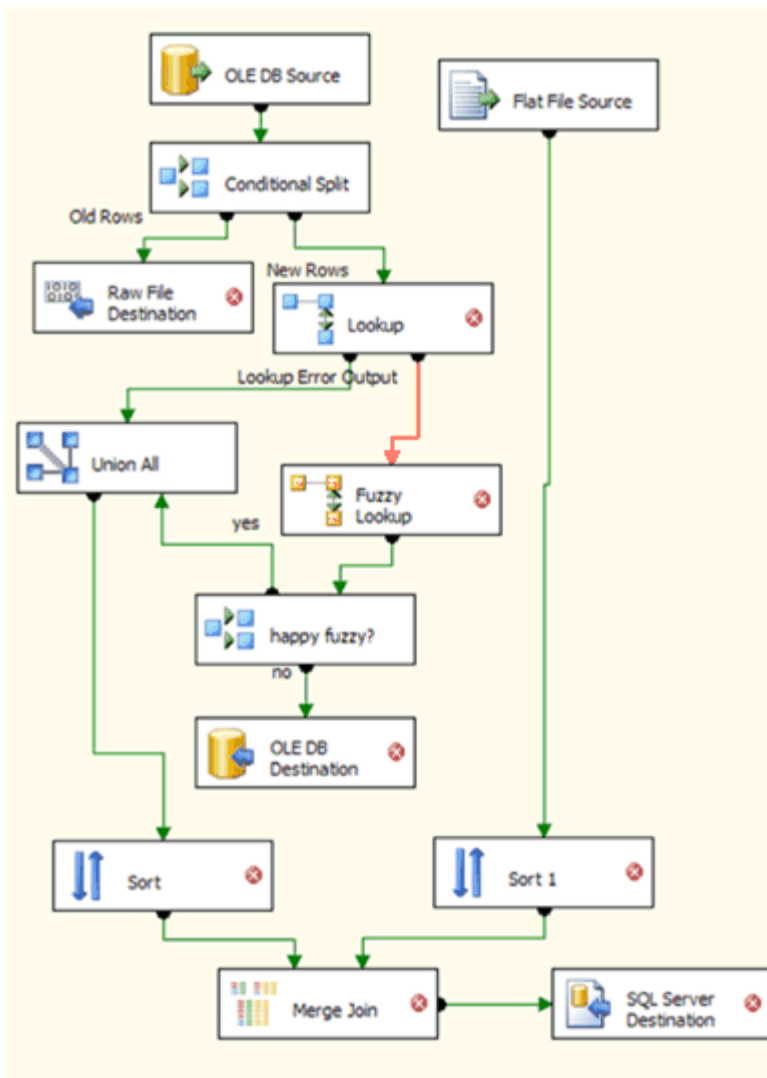

Figure 2: Data flow described by DTSX structure

Differences between DTSX and DTSX 2.0

DTSX version 2.0 is an enhanced refactoring of the XML that is documented in [\[MS-DTSX\]](#). Both [\[MS-DTSX\]](#) and [\[MS-DTSX2\]](#) describe the package files that are used by Integration Services. DTSX 2.0 will be used for package files starting with Microsoft® SQL Server® 2012.

DTSX 2.0 has the following XML refactoring changes from DTSX:

- DTSX has **Property** elements with a **Name** attribute to specify the property name. In DTSX 2.0, named properties are XML attributes of the parent element. However, a small number of named **Property** elements remain in DTSX 2.0.
- Some new attributes have been added to DTSX 2.0.
- To organize the larger number of attributes in DTSX 2.0, **AttributeGroup** groups of attributes have been defined, and are referenced by the complex type definitions in the XSD of DTSX 2.0.

- DTSX 2.0 specifies defaults for most attribute values, and sets the XSD **usage** attribute to "optional" for attributes with defaults. In DTSX, all of the property elements are always present, even if the element value is equal to the default value.
- In places where repeated element instances were allowed in DTSX, these repeated elements have been placed inside a parent element to hold the collection in DTSX 2.0, in most cases. For example, if multiple [Executable](#) elements appear within a package file, the Executable elements are contained in a parent **Executables** element in DTSX 2.0.

1.4 Relationship to Protocols and Other Structures

The usual structure format is clear-text XML [\[XML10\]](#).

1.5 Applicability Statement

This document describes an XML-based file persistence format that is used to describe a data flow that can be processed by a processing engine.

1.6 Versioning and Localization

The structure does not contain versioning features.

All string values contained in the structure are Unicode, which allows for any language that has a Unicode-defined character set.

1.7 Vendor-Extensible Fields

The DTSX structure allows for vendor extensibility. Vendors can add custom-programmed objects of the following types to the system, and therefore to the DTSX structure:

- Executable
- ConnectionManager
- Log provider
- ForEachEnumerator
- Component

The following table lists the affected elements, attributes, properties, or types for each of the above cases.

Custom item	Reference	Elements, attributes, properties, or types
Executable	Custom Executable	ObjectData element, AnyNonPackageExecutableTypeExecutableTypeEnum type
ConnectionManager	Custom ConnectionManager	ObjectData element
LogProvider	Custom Log Provider	None
ForEachEnumerator	Custom ForEachEnumerator	ObjectData element

Custom item	Reference	Elements, attributes, properties, or types
Component	Custom Component	PipelineComponentComponentClassIDEnum type, PipelineComponentPropertyNameEnum type, PipelineComponentInputPropertyNameEnum type, PipelineComponentOutputPropertyNameEnum type, PipelineComponentInputColumnPropertyNameEnum type, PipelineComponentOutputColumnPropertyNameEnum type

2 Structures

This section contains the definition of the DTSX structure. DTSX structure instances are contained in a single file called a **package file**.

The usual structure format is clear-text XML [\[XML10\]](#). The XML MAY be encrypted. [<1>](#) XML Schema is used to describe the DTSX structure [\[XMLSCHEMA1\]](#) [\[XMLSCHEMA2\]](#).

2.1 Additional Normative Requirements Concerning the XSD Fragments Provided

2.1.1 Constraints beyond the XSD Definitions for Complex Types

Each section of the structure definition has an accompanying XSD to define the type for a particular element of the structure. However, in some cases there are additional constraints on what can be contained in a defined element that go beyond what is expressed in the XSD. These constraints MUST be followed. Any such constraints for each complex type are noted in the tables and information that accompany the XSD within each section.

In the tables that follow XSD fragments, the "Constraints" column specifies constraints that are beyond the constraints that are expressed in the XSD. All specified constraints MUST be adhered to.

2.1.2 `<xs:sequence>` Usage Expressed in the XSD is Optional

Throughout this structure definition, the `<xs:sequence>` XSD construct is used. However, the Microsoft® SQL Server® Integration Services (SSIS) system does not enforce that the elements actually be in the stated sequence. Elements MAY appear in any order within the `<xs:sequence>` tags. [<2>](#)

2.2 Namespaces

This specification defines and references various XML namespaces using the mechanisms that are specified in [\[XMLNS\]](#). Although this specification associates a specific XML namespace prefix for each XML namespace that is used, the choice of any particular XML namespace prefix is implementation-specific and is not significant for interoperability.

Prefix	Namespace URI	Reference
DTS	www.microsoft.com/SqlServer/Dts	Currently not published. See section 5.1 .
WSTask	www.microsoft.com/sqlserver/dts/tasks/webservicetask	Currently not published. See section 5.2 .
MessageQueueTask	www.microsoft.com/sqlserver/dts/tasks/messagequeuetask	Currently not published. See section 5.3 .
SendMailTask	www.microsoft.com/sqlserver/dts/tasks/sendmailtask	Currently not published. See section 5.4 .
ActiveXScriptTask	www.microsoft.com/sqlserver/dts/tasks/messagequeuetask	Currently not published. See

Prefix	Namespace URI	Reference
		section 5.5 .
Exec80PackageTask	www.microsoft.com/sqlserver/dts/tasks/exec80packagetask	Currently not published. See section 5.6 .
BulkInsertTask	www.microsoft.com/sqlserver/dts/tasks/exec80packagetask	Currently not published. See section 5.7 .
SQLTask	www.microsoft.com/sqlserver/dts/tasks/exec80packagetask	Currently not published. See section 5.8 .

2.3 Executable Element

All Microsoft® SQL Server® Integration Services (SSIS) packages MUST contain a single root element. This element is the **Executable** element. The root **Executable** element MUST be of type **DTS:ExecutableTypePackage**.

The following is the XSD for the **Executable** root element.

```
<xs:element name="Executable" type="DTS:ExecutableTypePackage"/>
```

2.4 ExecutableTypePackage

The **ExecutableTypePackage** complex type defines the content of the [Executable](#) root element.

The following is the XSD definition for the **ExecutableTypePackage** complex type.

```
<xs:complexType name="ExecutableTypePackage">
  <xs:sequence>
    <xs:element name="Property" maxOccurs="unbounded">
      <xs:complexType>
        <xs:complexContent>
          <xs:extension base="DTS:PropertyElementBaseType">
            <xs:attribute name="Name"
              type="DTS:ExecutableTypePackagePropertyNameEnum"
              use="required"/>
          </xs:extension>
        </xs:complexContent>
      </xs:complexType>
    </xs:element>
    <xs:element name="ConnectionManagers" type="DTS:ConnectionManagersType"
      minOccurs="0"/>
    <xs:element name="Configurations" type="DTS:ConfigurationsType"
      minOccurs="0"/>
    <xs:element name="LogProviders" type="DTS:LogProvidersType"
      minOccurs="0"/>
    <xs:element name="Variables" type="DTS:VariablesType"
      minOccurs="0"/>
    <xs:element name="LoggingOptions" type="DTS:LoggingOptionsType" />
  </xs:sequence>
</xs:complexType>
```

```

<xs:element name="PropertyExpression"
            type="DTS:PropertyExpressionElementType"
            minOccurs="0" maxOccurs="unbounded"/>
<xs:element name="Executables" type="DTS:ExecutablesType"
            minOccurs="0"/>
<xs:element name="PrecedenceConstraints" minOccurs="0"
            type="DTS:PrecedenceConstraintsType"/>
<xs:element name="EventHandlers" type="DTS:EventHandlersType"
            minOccurs="0"/>
<xs:element name="PackageVariables" type="DTS:PackageVariablesType"
            minOccurs="0" maxOccurs="unbounded"/>
<xs:element name="PackageParameters" type="DTS:PackageParametersType" minOccurs="0"
            maxOccurs="1" />
</xs:sequence>
<xs:attribute name="ExecutableType" use="required"
            fixed="SSIS.Package.2" />
<xs:attributeGroup ref="DTS:AllExecutableAttributeGroup"/>
<xs:attributeGroup ref="DTS:BaseExecutablePropertyAttributeGroup"/>
<xs:attributeGroup ref="DTS:BasePropertyAttributeGroup"/>
<xs:attributeGroup ref="DTS:ExecutableTypePackageAttributeGroup"/>
<xs:attribute name="refId" type="xs:string" use="required"
            form="qualified"/>
</xs:complexType>

```

The following table provides additional information about the elements and types in the **ExecutableTypePackage** complex type.

Element	Constraints	Type definition	Description
Property	In some cases, constraints are placed on the Property element's value for specific values of the Name attribute of the Property element. If such constraints exist, they are specified where the meaning of the particular property name is specified. These constraints MUST be followed. If the optional DataType attribute is present, the value of the Property element MUST be of the type indicated by the DataType attribute.	Inline in the XSD in this section.	Property elements specify values for many different properties that are associated with an instance of the containing Executable element, according to the Name attribute of each Property element.
ConnectionManagers	None	ConnectionManagersType	Specifies a collection of elements of type ConnectionManagerType . Each such element defines a connection that is available to the package.
Configurations	None	ConfigurationsType	Specifies a collection of elements of type

Element	Constraints	Type definition	Description
			ConfigurationType . Each such element defines a connection that is available to the package.
LogProviders	None	SelectedLogProvidersType	Specifies a collection of elements of type LogProviderType . Each such element defines a log provider that is available to the package.
Variables	None	VariablesType	Specifies a collection of elements of type VariableType . Each such element defines a variable that is available to the package.
LoggingOptions	None	LoggingOptionsType	Specifies information about what kind of information is logged for this package and where it is recorded.
PropertyExpression	Additional constraints exist for the PropertyExpression element. For a description of these constraints, see PropertyExpressionElement .	PropertyExpressionElement	Serves the same purpose as specified for the Property element except that an expression that is evaluated at run time is contained in the element's value.
Executables	None	ExecutablesType	Specifies a collection of elements of type AnyNonPackageExecutableType . Each such element defines an executable that is available to the package.
PrecedenceConstraints	None	PrecedenceConstraintsType	Specifies a collection of elements of type PrecedenceConstraintType . Each such element defines a precedence constraint that is available to the package.
EventHandlers	None	EventHandlersType	Specifies a collection of elements of type EventHandlerType . Each such element defines an event handler that is available to the package.
PackageVariables	None	PackageVariablesType	Specifies a collection of elements of type PackageVariableType .

Element	Constraints	Type definition	Description
			Each such element defines a package variable that is available to the package.

The following table provides additional information about the attributes, attribute groups, and types for the **ExecutableTypePackage** type.

Attribute	Description
ExecutableType	Specifies information about the contents of the Executable element on which the attribute value appears.
AllExecutableAttributeGroup	An attribute group that specifies attributes that are common to many different types throughout the schema.
BaseExecutablePropertyAttributeGroup	An attribute group that specifies attributes that are common to many different types throughout the schema.
BasePropertyAttributeGroup	An attribute group that specifies attributes that are common to many different types throughout the schema.
ExecutableTypePackageAttributeGroup	An attribute group that specifies attributes for the ExecutableTypePackage type.
refId	A string value that specifies a unique refId for this object. Elsewhere within the containing executable or within the package, the value of refId can be used to refer to this object. <3>

2.4.1 PackageVariablesType

The **PackageVariablesType** complex type is the container type for a collection of elements of type [PackageVariableType](#).

The following is the XSD of the **PackageVariablesType** type.

```
<xs:complexType name="PackageVariablesType">
  <xs:sequence>
    <xs:element name="PackageVariable" type="DTS:PackageVariableType"
      minOccurs="0" maxOccurs="unbounded" form="qualified"/>
  </xs:sequence>
</xs:complexType>
```

The following table provides additional information about the elements, types, and constraints for the **PackageVariablesType** complex type.

Element	Type definition	Description
PackageVariable	PackageVariableType	Specifies a PackageVariable element that contains the values and content for a package variable.

2.4.1.1 PackageVariableType

The **PackageVariableType** complex type is used to specify **package variables**. Package variables are used to save screen information so that the Microsoft® SQL Server® Integration Services (SSIS) user interface editor can present the screen for editing in the same state as it was left in.

The following is the XSD for the **PackageVariableType** complex type.

```
<xs:complexType name="PackageVariableType">
  <xs:sequence>
    <xs:element name="Property"
      maxOccurs="unbounded">
      <xs:complexType>
        <xs:complexContent>
          <xs:extension base="DTS:PropertyElementBaseType">
            <xs:attribute name="Name"
              type="DTS:PackageVariablePropertyNameEnum"
              use="required"/>
          </xs:extension>
        </xs:complexContent>
      </xs:complexType>
    </xs:element>
    <xs:element name="PropertyExpression"
      type="DTS:PropertyExpressionElementType"
      minOccurs="0" maxOccurs="unbounded"/>
  </xs:sequence>
</xs:complexType>
```

The following table provides additional information about the elements, types, and constraints in the **PackageVariableType** complex type.

Element	Additional constraints	Type definition	Description
Property	In some cases, constraints are placed on the Property element's value for specific values of the Name attribute of the Property element. If such constraints exist, they are specified where the meaning of the particular property name is specified. These constraints MUST be followed. If the optional Data Type attribute is present, the value of the Property element MUST be of the type that is	Inline in the XSD in this section.	Property elements contain values for many different properties that are associated with an instance of the containing Executable element, according to the Name attribute of each Property element.

Element	Additional constraints	Type definition	Description
	specified by the Data attribute.		
PropertyExpression	Additional constraints exist for the PropertyExpression element.	PropertyExpressionElementType	The PropertyExpression element serves the same purpose as specified for the Property element, except that an expression that is evaluated at run time is contained in the element's value that is stored in the Integration Services file format.

The following table provides additional information about the attributes and types for the **Property** element that is declared inline in the complex type declaration. The **Property** element is an extension of the **PropertyElementBaseType** type with the addition of the **Name** attribute, which is specified in the following table.

Attribute	Constraints	Description
Name	None	Specifies the name of the property. Each named property has its own use and interpretation. The meaning of each named property is given with the definition of the type for the Name attribute.

2.4.1.1.1 PackageVariablePropertyNameEnum

The **PackageVariablePropertyNameEnum** type contains the values for the **Name** attribute of the property elements that are allowed for the [PackageVariableType](#) complex type.

The following is the XSD for the **PackageVariablePropertyNameEnum** type.

```
<xs:simpleType name="PackageVariablePropertyNameEnum">
  <xs:union memberTypes="DTS:BasePropertyNameEnum">
    <xs:simpleType>
      <xs:restriction base="xs:string">
        <xs:enumeration value="PackageVariableValue"/>
        <xs:enumeration value="PackageVariable"/>
        <xs:enumeration value="Namespace"/>
      </xs:restriction>
    </xs:simpleType>
  </xs:union>
</xs:simpleType>
```

The following table specifies the enumeration values for the **PackageVariablePropertyNameEnum** type. The **PackageVariablePropertyNameEnum** type is a union of the **BasePropertyNameEnum** type with the values that are specified in the following

table. The values described in this table do not include the values already specified for the **BasePropertyNameEnum** type.

Enumeration value	Description
PackageVariableValue	The PackageVariableValue enumeration value specifies that the element contains text that specifies screen locations for visual design of packages. It is not in the scope of this document to describe the interpretation of this text.
PackageVariable	The PackageVariable enumeration value is a synonym for PackageVariableValue .
Namespace	The Namespace enumeration value specifies that the element value contains an additional qualifier that enables unique identification of a package variable. Two package variables that have the same name can be distinguished by having a different Namespace value.

2.4.2 ConfigurationsType

The **ConfigurationsType** complex type is the container type for a collection of elements of type [ConfigurationType](#).

The following is the XSD of the **ConfigurationsType** type.

```
<xs:complexType name="ConfigurationsType">
  <xs:sequence>
    <xs:element name="Configuration" type="DTS:ConfigurationType"
      minOccurs="0" maxOccurs="unbounded" form="qualified"/>
  </xs:sequence>
</xs:complexType>
```

The following table provides additional information about the elements, types, and constraints for the **ConfigurationsType** complex type.

Element	Type definition	Description
Configuration	ConfigurationType	Specifies a Configuration element, which contains the options, parameters, and settings for a configuration.

2.4.2.1 ConfigurationType

The **ConfigurationType** complex type contains configuration information that is accessed by other elements within the package.

The following is the XSD for the **ConfigurationType** complex type.

```
<xs:complexType name="ConfigurationType">
  <xs:sequence>
    <xs:element name="PropertyExpression"
      type="DTS:PropertyExpressionElementType"
      minOccurs="0" maxOccurs="unbounded"/>
  </xs:sequence>
  <xs:attributeGroup ref="DTS:BasePropertyAttributeGroup"/>
</xs:complexType>
```

```
<xs:attributeGroup ref="DTS:ConfigurationAttributeGroup"/>
</xs:complexType>
```

The following table provides additional information about the elements, types, and constraints in the **ConfigurationType** complex type.

Element	Additional constraints	Type definition	Description
PropertyExpression	Additional constraints exist for the PropertyExpression element.	PropertyExpressionElementType	The PropertyExpression element serves the same purpose as described for the Property element, except that an expression that is evaluated at run time is contained in the element's value that is stored in the Microsoft® SQL Server® Integration Services (SSIS) file format.

The following table provides additional information about the attributes, attribute groups, and types for the **ConfigurationType** type.

Attribute	Description
BasePropertyAttributeGroup	An attribute group that specifies attributes that are common to many different types throughout the schema.
ConfigurationAttributeGroup	An attribute group that specifies attributes for the ConfigurationType type.

2.4.2.1.1 ConfigurationAttributeGroup

The **ConfigurationAttributeGroup** attribute group contains the attributes for the [ConfigurationType](#) type.

The following is the XSD for the **ConfigurationAttributeGroup** attribute group.

```
<xs:attributeGroup name="ConfigurationAttributeGroup">
  <xs:attribute name="ConfigurationType" type="DTS:ConfigurationTypeEnum"
    default="0" use="optional" form="qualified"/>
  <xs:attribute name="ConfigurationString" type="xs:string" default=""
    use="optional" form="qualified"/>
  <xs:attribute name="ConfigurationVariable" type="xs:string" default=""
    use="optional" form="qualified"/>
</xs:attributeGroup>
```

The following table specifies the attributes for the **ConfigurationAttributeGroup** attribute group.

Attribute	Description
ConfigurationType	An enumeration value that specifies the source from which the configuration is read.
ConfigurationString	A string value that is used to institute the configuration. The use of the string varies with the setting for ConfigurationType .
ConfigurationVariable	A string value that specifies the full path, within the package, to the property that is being configured.

2.4.2.1.1.1 ConfigurationTypeEnum

The **ConfigurationTypeEnum** type contains the enumeration values that specify the sources from which a configuration can be read.

The following is the XSD of the **ConfigurationTypeEnum** type.

```
<xs:simpleType name="ConfigurationTypeEnum">
  <xs:restriction base="xs:int">
    <xs:minInclusive value="0"/>
    <xs:maxInclusive value="10"/>
  </xs:restriction>
</xs:simpleType>
```

The following table specifies the descriptions for the enumeration values of the **ConfigurationTypeEnum** type.

Enumeration value	Description
0	A parent variable.
1	A configuration file.
2	An environment variable.
3	A registry entry.
4	A parent variable, indirect method .
5	A configuration file, indirect method.
6	A registry entry, indirect method.
7	A database table.
8	An INI file .
9	A database server, indirect method.
10	An INI file, indirect method.

2.4.3 LogProviderType

The **LogProviderType** complex type is used to define a particular log provider that is used by the package.

The following is the XSD for the **LogProviderType** complex type.

```
<xs:complexType name="LogProviderType" >
  <xs:sequence>
    <xs:element name="PropertyExpression"
      type="DTS:PropertyExpressionElementType"
      minOccurs="0" maxOccurs="unbounded"/>
    <xs:element name="ObjectData" type="DTS:LogProviderObjectDataType"/>
  </xs:sequence>
  <xs:attributeGroup ref="DTS:BasePropertyAttributeGroup"/>
  <xs:attributeGroup ref="DTS:LogProviderAttributeGroup"/>
</xs:complexType>
```

The following table provides additional information about the elements, types, and constraints in the **LogProviderType** complex type.

Element	Additional constraints	Type definition	Description
PropertyExpression	Additional constraints exist for the PropertyExpression element.	PropertyExpressionElementType	The PropertyExpression element serves the same purpose as specified for the Property element, except that an expression that is evaluated at runtime is contained in the element's value that is stored in the Microsoft® SQL Server® Integration Services (SSIS) file format.
ObjectData	None	LogProviderObjectDataType	Contains information that is specific to the LogProvider . For more information, see Executable ObjectData Types .

The following table provides additional information about the attributes, attribute groups, and types for the **LogProviderType** type.

Attribute	Description
BasePropertyAttributeGroup	An attribute group that specifies attributes that are common to many different types throughout the schema.

Attribute	Description
LogProviderAttributeGroup	An attribute group that specifies attributes for the LogProviderType type.

2.4.3.1 LogProviderAttributeGroup

The **LogProviderAttributeGroup** attribute group contains the attributes for the **LogProviderAttributeGroup** type.

The following is the XSD for the **LogProviderAttributeGroup** attribute group.

```
<xs:attributeGroup name="LogProviderAttributeGroup">
  <xs:attribute name="DelayValidation" type="DTS:BooleanStringCap"
    default="False" use="optional" form="qualified"/>
  <xs:attribute name="ConfigString" type="xs:string" default=""
    use="optional" form="qualified"/>
</xs:attributeGroup>
```

The following table specifies the attributes for the **LogProviderAttributeGroup** attribute group.

Attribute	Description
DelayValidation	A value of type DTS:BooleanStringCap that specifies whether validation is delayed until the Executable element that contains this LogProvider executes. "True": The validation of the LogProvider is delayed until the container is executed. "False": The validation of the LogProvider is not delayed until run time.
ConfigString	A string value. This value is used by each specific log provider in a different way.

2.4.3.2 LogProviderObjectType

The **LogProviderObjectType** complex type provides information that is specific to a particular instance of a **LogProvider** element.

The following is the XSD for the **LogProviderObjectType** complex type.

```
<xs:complexType name="LogProviderObjectType">
  <xs:sequence>
    <xs:element name="InnerObject" form="unqualified"
      type="DTS:InnerObjectObjectType"/>
  </xs:sequence>
</xs:complexType>
```

Element	Additional constraints	Type definition	Description
InnerObject	None	Inline in the XSD in this section.	Can contain additional information specific to an instance of a LogProvider element. <4>

2.4.4 ConnectionManagersType

The **ConnectionManagersType** complex type is the container type for a collection of elements of type [ConnectionManagerType](#).

The following is the XSD of the **ConnectionManagersType** complex type.

```
<xs:complexType name="ConnectionManagersType">
  <xs:sequence>
    <xs:element name="ConnectionManager" type="DTS:ConnectionManagerType"
      minOccurs="0" maxOccurs="unbounded" form="qualified"/>
  </xs:sequence>
</xs:complexType>
```

The following table provides additional information about the elements, types, and constraints for the **ConnectionManagersType** complex type.

Element	Type definition	Description
ConnectionManager	ConnectionManagerType	Specifies a ConnectionManager element, which contains the options, parameters, and settings for a connection manager.

2.4.4.1 ConnectionManagerType

The **ConnectionManagerType** complex type is used to specify a connection to a data source.

The following is the XSD of the **ConnectionManagerType** complex type.

```
<xs:complexType name="ConnectionManagerType">
  <xs:sequence>
    <xs:element name="PropertyExpression"
      type="DTS:PropertyExpressionElementType"
      minOccurs="0" maxOccurs="unbounded"/>
    <xs:element name="ObjectData"
      type="DTS:ConnectionManagerObjectDataType"/>
  </xs:sequence>
  <xs:attributeGroup ref="DTS:BasePropertyAttributeGroup"/>
  <xs:attributeGroup ref="DTS:ConnectionManagerAttributeGroup"/>
  <xs:attribute name="refId" type="xs:string" use="required"
    form="qualified"/>
</xs:complexType>
```

The following table provides additional information about the elements, types, and constraints in the **ConnectionManagerType** complex type.

Element	Additional constraints	Type definition	Description
PropertyExpression	Additional constraints exist for the PropertyExpression	PropertyExpressionElementType	The PropertyExpression element serves the same purpose as

Element	Additional constraints	Type definition	Description
	n element.		specified for the Property element, except that an expression that is evaluated at run time is contained in the element's value that is stored in the Microsoft® SQL Server® Integration Services (SSIS) file format. Properties contained in the ObjectData element can also become PropertyExpressions in this location.
ObjectData	The contents of the ObjectData element vary with the data source that the ConnectionManager element is specifying.	ConnectionManagerObjectDataTyped	Contains information that is specific to the containing ConnectionManager element. The nature of the information varies with the type of data that the connection manager is connecting to, which is specified by the CreationName property.

The following table provides additional information about the attributes, attribute groups, and types for the **ConnectionManagerType** complex type.

Attribute	Description
BasePropertyAttributeGroup	An attribute group that specifies attributes that are common to many different types throughout the schema.
ConnectionManagerAttributeGroup	An attribute group that specifies attributes for the ConnectionManagerType type.
refId	A string value that specifies a unique refId for this object. Elsewhere within the containing executable or within the package, the value of refId can be used to refer to this object. <5>

2.4.4.1.1 ConnectionManagerAttributeGroup

The **ConnectionManagerAttributeGroup** attribute group contains the attributes for the [ConnectionManagerType](#) type.

The following is the XSD for the **ConnectionManagerAttributeGroup** attribute group.

```

<xs:attributeGroup name="ConnectionManagerAttributeGroup">
  <xs:attribute name="DelayValidation" type="DTS:BooleanStringCap"
    default="False" use="optional" form="qualified"/>
</xs:attributeGroup>

```

The following table specifies the attributes for the **ConnectionManagerAttributeGroup** attribute group.

Attribute	Description
DelayValidation	A value of type DTS:BooleanStringCap that specifies whether or not validation is delayed until the container of this ConnectionManager executes. "False" specifies that the validation of the ConnectionManager is not delayed until run time. "True" specifies that the validation of the ConnectionManager is delayed until run time.

2.4.4.1.2 ConnectionManagerObjectDataType

The **ConnectionManagerObjectDataType** complex type is used to contain additional information that is specific to each type of data connection that is not expressed in the **Property** elements of a **ConnectionManager** instance.

The following is the XSD of the **ConnectionManagerObjectDataType** complex type.

```

<xs:complexType name="ConnectionManagerObjectDataType">
  <xs:choice>
    <xs:element name="ConnectionManager" type=
      "DTS:ConnectionManagerObjectDataConnectionManagerType"/>
    <xs:element name="MsmqConnectionManager" type=
      "DTS:ConnectionManagerObjectDataMsmqConnectionManagerType"
      form="unqualified"/>
    <xs:element name="SMOServerConnectionManager" type=
      "DTS:ConnectionManagerObjectDataSMOServerConnectionManagerType"
      form="unqualified"/>
    <xs:element name="SmtplibConnectionManager" type=
      "DTS:ConnectionManagerObjectDataSmtplibConnectionManagerType"
      form="unqualified"/>
    <xs:element name="WmiConnectionManager" type=
      "DTS:ConnectionManagerObjectDataWmiConnectionManagerType"
      form="unqualified"/>
  </xs:choice>
</xs:complexType>

```

The following table provides additional information about the elements, types, and constraints in the **ConnectionManagerType** complex type.

Element	Additional constraints	Type definition	Description
ConnectionManager	Depending on the type of the connection, there are limits on what can be placed in the	ConnectionManagerObjectDataConnectionManagerType	Contains information for the

Element	Additional constraints	Type definition	Description
	<p>ConnectionManager element. These constraints MUST be followed. Depending on the type of the connection, there are constraints on the allowed values for the attributes that are contained in the ConnectionManagerConnectionManagerAttributeGroup. These constraints MUST be followed.</p>		<p>following connection types:</p> <ul style="list-style-type: none"> OLE DB Flat file ADO.NET Analysis Services File Cache Excel FTP HTTP Multi-file Multi-Flat file Open Database Connectivity (ODBC) SQL Server Mobile
MsmqConnection Manager	None	ConnectionManagerObjectDataMsmqConnectionManagerType	Contains information that is specific to the MSMQ Connection Manager type.
SMOServerConnectionManager	None	ConnectionManagerObjectDataSMOServerConnectionManagerType	Contains information that is specific to the SMO Server Connection Manager type.
SmtplibConnection Manager	None	ConnectionManagerObjectDataSmtplibConnectionManagerType	Contains information that is specific to the Simple Mail Transfer Protocol (SMTP) Connection Manager

Element	Additional constraints	Type definition	Description
			type.
WmiConnectionManager	None	ConnectionManagerObjectDataWmiConnectionManagerType	Contains information that is specific to the Windows Management Instrumentation (WMI) Connection Manager type.

2.4.4.1.2.1 ConnectionManagerObjectDataConnectionManagerType

The **ObjectData** element in the **ConnectionManager** contains a **ConnectionManager** element of type **ConnectionManagerObjectDataConnectionManagerType** when the data source is one of the following:

- OLE DB
- Flat File
- ADO.NET
- Analysis Services
- File
- Cache
- Excel
- FTP
- HTTP
- Multi-file
- Multiple flat file
- ODBC
- SQL Server Mobile

The following is the XSD of the **ConnectionManagerObjectDataConnectionManagerType** type.

```
<xs:complexType
  name="ConnectionManagerObjectDataConnectionManagerType">
  <xs:sequence>
    <xs:choice minOccurs="0">
      <xs:element name="FlatFileColumns" type="DTS:FlatFileColumnsType"/>
    </xs:choice>
  </xs:sequence>
</xs:complexType>
```

```

    <xs:element name="CacheColumns" type="DTS:CacheColumnsType"
        maxOccurs="unbounded"/>
    <xs:element name="FtpConnection" type="DTS:FtpConnectionType"/>
    <xs:element name="HttpConnection" type="DTS:HttpConnectionType"/>
  </xs:choice>
</xs:sequence>
<xs:attributeGroup
  ref="DTS:ConnectionManagerConnectionManagerAttributeGroup"/>
</xs:complexType>

```

The following table provides additional information about the elements, types, and constraints in the **ConnectionManagerType** complex type.

Element	Additional constraints	Type definition	Description
FlatFileColumn	The FlatFileColumn element MUST NOT appear unless the data source for the ConnectionManager is a flat file or is multiple flat files. The FlatFileColumn element MUST be included if the data source for the ConnectionManager is a flat file or is multiple flat files.		Contains the definition of a flat file column that is present in the data source.
CacheColumn	The CacheColumn element MUST NOT appear unless the data source for the ConnectionManager is a Cache data source. The CacheColumn element MUST be included if the data source is Cache data.		Contains the definition of a cache column that is present in the data source.
FtpConnection	The FtpConnection element MUST NOT appear unless the data source for the ConnectionManager is an FTP data source. The FtpConnection element MUST be included if the data source is an FTP data source.		Contains the properties of an FTP connection.
HttpConnection	The HttpConnection element MUST NOT appear unless the data source for the ConnectionManager is an HTTP data source. The HttpConnection element MUST be included if the data source is an HTTP data source.		Contains the properties of an HTTP connection.

The following table provides additional information about the attributes, attribute groups, and types for the **ConfigurationType** type.

Attribute	Description
ConnectionManagerConnectionManagerAttributeGroup	An attribute group that specifies attributes for the ConnectionManagerObjectDataConnectionManagerType type.

2.4.4.1.2.1.1 ConnectionManagerConnectionManagerAttributeGroup

The **ConnectionManagerConnectionManagerAttributeGroup** attribute group contains the attributes for the [ConnectionManagerObjectDataConnectionManagerType](#) type.

The following is the XSD for the **ConnectionManagerConnectionManagerAttributeGroup** attribute group.

```
<xs:attributeGroup name="ConnectionManagerConnectionManagerAttributeGroup">
  <xs:attribute name="Retain" type="DTS:BooleanStringCap" default="False"
    use="optional" form="qualified"/>
  <xs:attribute name="ConnectionString" type="xs:string" use="required"
    form="qualified"/>
  <xs:attribute name="FileUsageType" type="DTS:FileUsageTypeEnum"
    default="0" use="optional" form="qualified"/>
  <xs:attribute name="Format" type="DTS:FormatEnum" use="optional"
    form="qualified"/>
  <xs:attribute name="LocaleID" type="xs:int" use="optional"
    form="qualified"/>
  <xs:attribute name="Unicode" type="DTS:BooleanStringCap" default="False"
    use="optional" form="qualified"/>
  <xs:attribute name="HeaderRowsToSkip" type="xs:int" default="0"
    use="optional" form="qualified"/>
  <xs:attribute name="HeaderRowDelimiter" type="xs:string" use="optional"
    form="qualified"/>
  <xs:attribute name="ColumnNamesInFirstDataRow" default="False"
    type="DTS:BooleanStringCap" use="optional" form="qualified"/>
  <xs:attribute name="RowDelimiter" type="xs:string" use="optional"
    form="qualified"/>
  <xs:attribute name="DataRowsToSkip" type="xs:int" default="0"
    use="optional" form="qualified"/>
  <xs:attribute name="TextQualifier" type="xs:string" use="optional"
    form="qualified"/>
  <xs:attribute name="CodePage" type="xs:int" use="optional"
    form="qualified"/>
  <xs:attribute name="ServerName" type="xs:string" use="optional"
    form="qualified"/>
  <xs:attribute name="UseFile" type="DTS:BooleanStringCap"
    default="False" use="optional" form="qualified"/>
  <xs:attribute name="UseEncryption" type="DTS:BooleanStringCap"
    default="False" use="optional" form="qualified"/>
  <xs:attribute name="RetainData" type="DTS:BooleanStringCap"
    default="True" use="optional" form="qualified"/>
</xs:attributeGroup>
```

The following table specifies the attributes for the **ConnectionManagerConnectionManagerAttributeGroup** attribute group.

Attribute	Description
Retain	A value of type DTS:BooleanStringCap that specifies whether the same connection is retained between successive data accesses. "False" specifies that the connection is not retained between successive data accesses "True" specifies that the connection is retained between success data accesses.
ConnectionString	A string value that is handed to the data source upon connection. The contents of the string vary with the source type.
FileUsageType	An enumeration value that specifies how the file connection is used.

Attribute	Description
Format	An enumeration value that specifies the type of formatting in the records and fields of a file.
LocaleID	An integer value that specifies the language code identifier (LCID) for the language for this executable. <6>
Unicode	A value of type DTS:BooleanStringCap that specifies an indicator for whether the data source contains Unicode characters. "False" indicates that the data obtained from the connection is not Unicode. "True" specifies that the data obtained from the connection is Unicode.
HeaderRowsToSkip	An integer value that represents the number of header rows to skip in the data source.
HeaderRowDelimiter	A string value that specifies a hexadecimal-encoded value in ASCII [US-ASCII] for the character or character string that is the delimiter for the header row. Each such character MUST be prepended and post-pended with an underscore (_) character. For example, the string "_x000D_x000A_" specifies the sequence of characters: a carriage return character followed by a line feed character.
ColumnNamesInFirstDataRow	An enumeration value that specifies whether the first row contains column names. "False" specifies that the first row does not contain column names. "True" specifies that the first data row contains column names.
RowDelimiter	A string value that specifies the row delimiter. <7>
DataRowsToSkip	An integer value that specifies the number of data rows to skip.
TextQualifier	A string value that specifies a character that is used to indicate text values.
CodePage	Specifies that the element value is the numeric value of the ANSI code page that is used for strings. <8>
ServerName	A string value that specifies the name of the server for the connection.
UseFile	A value of type DTS:BooleanStringCap that specifies whether the cache is backed by a cache file on disk or stored only in memory. "True" specifies that a file is used. "False" specifies that the cache is stored only in memory and erased when the package terminates.
UseEncryption	A value of type DTS:BooleanStringCap that specifies whether to use encryption for data access. "True" specifies not to use encryption for data access. "False" specifies to use encryption for data access.
RetainData	A value of type DTS:BooleanStringCap that specifies whether data is retained. <9> "True" specifies that data is retained.

Attribute	Description
	"False" specifies that data is not retained.

2.4.4.1.2.1.1.1 FormatEnum

The **FormatEnum** type contains the enumeration values that specify how the file connection is used.

The following is the XSD of the **FormatEnum** type.

```
<xs:simpleType name="FormatEnum">
  <xs:restriction base="xs:string">
    <xs:enumeration value="Delimited"/>
    <xs:enumeration value="FixedWidth"/>
    <xs:enumeration value="RaggedRight"/>
  </xs:restriction>
</xs:simpleType>
```

The following table specifies the descriptions for the enumeration values of the **FormatEnum** type.

Element value	Description
Delimited	Specifies that the format of the file contains fields that are delimited with a delimiter.
FixedWidth	Specifies that the format of the file contains fields that are of fixed width.
RaggedRight	Specifies that the format of the file contains records that can be truncated on the right.

2.4.4.1.2.1.1.2 FileUsageTypeEnum

The **FileUsageTypeEnum** type contains the enumeration values that specify how the file connection is used.

The following is the XSD of the **FileUsageTypeEnum** type.

```
<xs:simpleType name="FileUsageTypeEnum">
  <xs:restriction base="xs:int">
    <xs:minInclusive value="0"/>
    <xs:maxInclusive value="3"/>
  </xs:restriction>
</xs:simpleType>
```

The following table specifies the descriptions for the enumeration values of the **FileUsageTypeEnum** type.

Enumeration value	Description
0	Specifies that the file connection manager uses an existing file.
1	Specifies that the file connection manager creates a file.

Enumeration value	Description
2	Specifies that the file connection manager uses an existing folder.
3	Specifies that the file connection manager creates a folder.

2.4.4.1.2.1.2 FlatFileColumnsType

The **FlatFileColumnsType** complex type is the container type for a collection of elements of type [FlatFileColumnType](#).

The following is the XSD of the **FlatFileColumnsType** complex type.

```
<xs:complexType name="FlatFileColumnsType">
  <xs:sequence>
    <xs:element name="FlatFileColumn" type="DTS:FlatFileColumnType"
      minOccurs="0" maxOccurs="unbounded"/>
  </xs:sequence>
</xs:complexType>
```

The following table provides additional information about the elements, types, and constraints for the **FlatFileColumnsType** complex type.

Element	Type definition	Description
FlatFileColumn	FlatFileColumnType	Specifies a FlatFileColumn element that contains the options, parameters, and settings for a column of a flat file.

2.4.4.1.2.1.2.1 FlatFileColumnType

The **FlatFileColumnType** complex type gives the definition of a column that is contained in a flat file data source.

The following is the XSD of the **FlatFileColumnType** complex type.

```
<xs:complexType name="FlatFileColumnType">
  <xs:sequence/>
  <xs:attributeGroup ref="DTS:BasePropertyAttributeGroup"/>
  <xs:attributeGroup ref="DTS:FlatFileColumnAttributeGroup"/>
</xs:complexType>
```

The **FlatFileColumnType** complex type contains no elements.

The following table provides additional information about the attributes, attribute groups, and types for the **ConfigurationType** complex type.

Attribute	Description
BasePropertyAttributeGroup	An attribute group that specifies attributes that are common to many different types throughout the schema.
FlatFileColumnAttributeGroup	An attribute group that specifies attributes for the FlatFileColumnType

Attribute	Description
	complex type.

2.4.4.1.2.1.2.1.1 FlatFileColumnAttributeGroup

The **FlatFileColumnAttributeGroup** attribute group contains the attribute for the [FlatFileType](#) type.

The following is the XSD for the **FlatFileColumnAttributeGroup** attribute group.

```
<xs:attributeGroup name="FlatFileColumnAttributeGroup">
  <xs:attribute name="ColumnType" type="DTS:ColumnTypeEnum"
    default="FixedWidth" use="optional" form="qualified"/>
  <xs:attribute name="ColumnDelimiter" type="xs:string"
    use="required" form="qualified"/>
  <xs:attribute name="ColumnWidth" type="xs:int" default="0"
    use="optional" form="qualified"/>
  <xs:attribute name="MaximumWidth" type="xs:int" default="0"
    use="optional" form="qualified"/>
  <xs:attribute name="DataType" type="DTS:DtsDataTypeEnum" default="0"
    use="optional" form="qualified"/>
  <xs:attribute name="DataPrecision" type="xs:int" default="0"
    use="optional" form="qualified"/>
  <xs:attribute name="DataScale" type="xs:int" default="0" use="optional"
    form="qualified"/>
  <xs:attribute name="TextQualified" type="DTS:BooleanStringCap"
    default="False" use="optional" form="qualified"/>
</xs:attributeGroup>
```

The following table specifies the attributes for the **FlatFileColumnAttributeGroup** attribute group.

Attribute	Description
ColumnType	An enumeration value that specifies whether the column is delimited or fixed width.
ColumnDelimiter	A string value that specifies the column delimiter in the file.
ColumnWidth	An integer value that specifies the width of the column. This value is used if the ColumnTypeProperty value is "FixedWidth".
MaximumWidth	An integer value that specifies the maximum number of bytes to be read from the buffer.
DataType	An enumeration value that specifies the data type of the column.
DataPrecision	An integer value that specifies the total digits in a numeric data type.
DataScale	An integer value that specifies the number of digits to the right of the decimal point.
TextQualified	A value of type DTS:BooleanStringCap that specifies whether the column is text-qualified. "True" specifies that the column is text-qualified. "False" specifies that the column is not-text qualified.

2.4.4.1.2.1.2.1.2 ColumnTypeEnum

The **ColumnTypeEnum** type contains the enumeration values that specify whether the column is delimited or of fixed width.

The following is the XSD of the **ColumnTypeEnum** type.

```
<xs:simpleType name="ColumnTypeEnum">
  <xs:restriction base="xs:string">
    <xs:enumeration value="Delimited"/>
    <xs:enumeration value="FixedWidth"/>
  </xs:restriction>
</xs:simpleType>
```

The following table specifies the descriptions for the enumeration values of the **ColumnTypeEnum** type.

Enumeration value	Description
Delimited	Specifies that the column values are delimited by a delimiter.
FixedWidth	Specifies that the column values are of fixed width.

2.4.4.1.2.1.3 CacheColumnsType

The **CacheColumnsType** complex type is the container type for a collection of elements of type [CacheColumnType](#).

The following is the XSD of the **CacheColumnsType** type.

```
<xs:complexType name="CacheColumnsType">
  <xs:sequence>
    <xs:element name="CacheColumn" type="DTS:CacheColumnType"
      minOccurs="0" maxOccurs="unbounded"/>
  </xs:sequence>
</xs:complexType>
```

The following table provides additional information about the elements, types, and constraints for the **CacheColumnsType** complex type.

Element	Type definition	Description
CacheColumn	CacheColumnType	Specifies a CacheColumn element that contains the options, parameters, and settings for a cache column.

2.4.4.1.2.1.3.1 CacheColumnType Complex Type

The **CacheColumnType** complex type specifies the definition of a column that is contained in a Cache data source.

The following is the XSD for the **CacheColumnType** complex type.

```

<xs:complexType name="CacheColumnType">
  <xs:sequence/>
  <xs:attributeGroup ref="DTS:BasePropertyAttributeGroup"/>
  <xs:attributeGroup ref="DTS:CacheColumnAttributeGroup"/>
</xs:complexType>

```

The **CacheColumnType** complex type contains no elements.

The following table provides additional information about the attributes, attribute groups, and types for the **CacheColumnType** complex type.

Attribute	Description
BasePropertyAttributeGroup	An attribute group that specifies attributes that are common to many different types throughout the schema.
CacheColumnAttributeGroup	An attribute group that specifies attributes for the CacheColumnType complex type.

2.4.4.1.2.1.3.1.1 CacheColumnAttributeGroup

The **CacheColumnAttributeGroup** attribute group contains the attribute for the [CacheColumnType](#) complex type.

The following is the XSD for the **CacheColumnAttributeGroup** attribute group.

```

<xs:attributeGroup name="CacheColumnAttributeGroup">
  <xs:attribute name="DataType" type="DTS:DtsDataTypeEnum" default="0"
    use="optional" form="qualified"/>
  <xs:attribute name="Length" type="xs:int" default="0" use="optional"
    form="qualified"/>
  <xs:attribute name="Precision" type="xs:int" default="0" use="optional"
    form="qualified"/>
  <xs:attribute name="Scale" type="xs:int" default="0" use="optional"
    form="qualified"/>
  <xs:attribute name="CodePage" type="xs:int" default="0" use="optional"
    form="qualified"/>
  <xs:attribute name="IndexPosition" type="xs:int" default="0"
    use="optional" form="qualified"/>
</xs:attributeGroup>

```

The following table specifies the attributes for the **CacheColumnAttributeGroup** attribute group.

Attribute	Description
DataType	An enumeration value that specifies the data type of the column.
Length	An integer value that specifies the length of the cache column, in characters.
Precision	An integer value that specifies an integer that defines the total digits in a numeric data type.
Scale	An integer value that specifies the number of digits to the right of the decimal point.

Attribute	Description
CodePage	An integer value that specifies that the element value is the numeric value of the ANSI code page that is used for strings.
IndexPosition	An integer value that specifies the index position of the current cache column.

2.4.4.1.2.1.4 FtpConnectionType Complex Type

The **FtpConnectionType** complex type specifies the properties that are necessary to connect to an FTP data source.

The following is the XSD of the **FtpConnectionType** complex type.

```
<xs:complexType name="FtpConnectionType">
  <xs:sequence>
    <xs:element name="Property"
      minOccurs="0" maxOccurs="unbounded">
      <xs:complexType>
        <xs:complexContent>
          <xs:extension base="DTS:PropertyElementBaseType">
            <xs:attribute name="Name"
              type="DTS:FtpConnectionPropertyNameEnum"
              use="required"/>
            <xs:attribute name="Sensitive" form="unqualified">
              <xs:simpleType>
                <xs:restriction base="xs:int">
                  <xs:minInclusive value="0"/>
                  <xs:maxInclusive value="1"/>
                </xs:restriction>
              </xs:simpleType>
            </xs:attribute>
            <xs:attribute name="Encrypted" form="unqualified">
              <xs:simpleType>
                <xs:restriction base="xs:int">
                  <xs:minInclusive value="0"/>
                  <xs:maxInclusive value="1"/>
                </xs:restriction>
              </xs:simpleType>
            </xs:attribute>
          </xs:extension>
        </xs:complexContent>
      </xs:complexType>
    </xs:element>
  </xs:sequence>
  <xs:attributeGroup ref="DTS:FtpConnectionAttributeGroup"/>
</xs:complexType>
```

The following table provides additional information about the elements, types, and constraints in the **FtpConnectionType** complex type.

Element	Additional constraints	Type definition	Description
Property	In some cases, constraints are placed on	Inline in the	Property elements contain

Element	Additional constraints	Type definition	Description
	the Property element's value for specific values of the Name attribute of the Property element. If such constraints exist, they are specified where the meaning of the particular property name is specified. These constraints MUST be followed. If the optional DataType attribute is present, the value of the Property element MUST be of the type that is specified by the DataType attribute.	XSD in this section.	values for many different properties associated with an instance of the containing FlatFileColumn element, according to the Name attribute of each Property element.

The following table provides additional information about the attributes and types for the **Property** element that is declared inline in the complex type declaration. The **Property** element is an extension of the [PropertyElementBaseType](#) type, with the addition of the attributes that are specified in the following table.

Attribute	Constraints	Description
Name	None	Specifies the name of the Property element. Each named property has its own use and interpretation. The explanation for the interpretation of each named property is given with the definition of the type for the Name attribute.
Sensitive	None	The element value contains an indicator for whether the property information is treated as sensitive. The integer value has the following meanings: 0 specifies that the property value is not considered to be sensitive. 1 specifies that the property value is considered to be sensitive. Depending on the setting of the ProtectionLevel value in an ancestor level to the containing element, the value of the property can or cannot be displayed if the property is considered to be sensitive.
Encrypted	None	The element value contains an indicator for whether the property element value is encrypted. The integer value has the following meanings: 0 specifies that the property value is not encrypted. 1 specifies that the property value is encrypted.

2.4.4.1.2.1.4.1 FtpConnectionPropertyNameEnum

The **FtpConnectionPropertyNameEnum** type contains the values for the **Name** attribute of the property elements that are allowed for the **FtpConnectionType** type.

The following is the XSD for the **FtpConnectionPropertyNameEnum** type.

```
<xs:simpleType name="FtpConnectionPropertyNameEnum">
  <xs:restriction base="xs:string">
    <xs:enumeration value="ServerPassword"/>
  </xs:restriction>
</xs:simpleType>
```

The following table specifies the enumeration values for the **FtpConnectionPropertyNameEnum** type.

Enumeration value	Description
ServerPassword	Specifies a string that contains the password to use to access the FTP server.

2.4.4.1.2.1.4.2 FtpConnectionAttributeGroup

The **FtpConnectionAttributeGroup** attribute group contains the attribute for the [FtpConnectionType](#) type.

The following is the XSD for the **FtpConnectionAttributeGroup** attribute group.

```
<xs:attributeGroup name="FtpConnectionAttributeGroup">
  <xs:attribute name="ServerName" type="xs:string" use="required"
    form="qualified"/>
  <xs:attribute name="ServerPort" type="xs:int" default="21"
    use="optional" form="qualified"/>
  <xs:attribute name="ServerUserName" type="xs:string" default=""
    use="optional" form="qualified"/>
  <xs:attribute name="ChunkSize" type="xs:int" default="1" use="optional"
    form="qualified"/>
  <xs:attribute name="TimeOut" type="xs:int" default="60" use="optional"
    form="qualified"/>
  <xs:attribute name="Retries" type="xs:int" default="5" use="optional"
    form="qualified"/>
  <xs:attribute name="UsePassiveMode" type="DTS:BooleanStringCap"
    default="False" use="optional" form="qualified"/>
</xs:attributeGroup>
```

The following table specifies the attributes for the **FtpConnectionAttributeGroup** attribute group.

Enumeration value	Description
ServerName	A string value that specifies the name of the FTP server to connect to.
ServerPort	A string value that specifies the port for the connection.
ServerUserName	A string value that specifies the user name to use on the FTP server.
ChunkSize	An integer value that specifies the minimum number of bytes to receive or send.
TimeOut	An integer value that specifies the number of seconds to wait before the connection fails.
Retries	An integer value that specifies the number of times that the FTP connection attempts to send data before the connection fails.
UsePassiveMode	A value of type DTS:BooleanStringCap that specifies that the element value contains an indicator for whether the FTP connection uses passive mode . "False" specifies that active mode is used for the FTP connection. "True" specifies that passive mode is used for the FTP connection.

2.4.4.1.2.1.5 HttpConnectionType Complex Type

The **HttpConnectionType** complex type specifies the properties that are necessary to connect to an HTTP data source.

The following is the XSD of the **HttpConnectionType** complex type.

```
<xs:complexType name="HttpConnectionType">
  <xs:sequence>
    <xs:element name="Property"
      minOccurs="0" maxOccurs="unbounded">
      <xs:complexType>
        <xs:complexContent>
          <xs:extension base="DTS:PropertyElementBaseType">
            <xs:attribute name="Name"
              type="DTS:HttpConnectionPropertyNameEnum"
              use="required"/>
            <xs:attribute name="Sensitive" form="unqualified">
              <xs:simpleType>
                <xs:restriction base="xs:int">
                  <xs:minInclusive value="0"/>
                  <xs:maxInclusive value="1"/>
                </xs:restriction>
              </xs:simpleType>
            </xs:attribute>
            <xs:attribute name="Encrypted" form="unqualified">
              <xs:simpleType>
                <xs:restriction base="xs:int">
                  <xs:minInclusive value="0"/>
                  <xs:maxInclusive value="1"/>
                </xs:restriction>
              </xs:simpleType>
            </xs:attribute>
          </xs:extension>
        </xs:complexContent>
      </xs:complexType>
    </xs:element>
  </xs:sequence>
  <xs:attributeGroup ref="DTS:HttpConnectionAttributeGroup"/>
</xs:complexType>
```

The following table provides additional information about the attributes and types for the **Property** element that is declared inline in the complex type declaration. The **Property** element is an extension of the [PropertyElementBaseType](#) type, with the addition of the attributes that are specified in the following table.

Attribute	Constraints	Description
Name	None	Specifies the name of the Property element. Each named property has its own use and interpretation. The explanation for the interpretation of each named property is given with the definition of the type for the Name attribute.
Sensitive	None	The element value contains an indicator for whether the property information is treated as sensitive. The integer value has the following meanings:

Attribute	Constraints	Description
		0 specifies that the property value is not considered to be sensitive. 1 specifies that the property value is considered to be sensitive. Depending on the setting of the ProtectionLevel value in an ancestor level to the containing element, the value of the property can or cannot be displayed if the property is considered to be sensitive.
Encrypted	None	The element value contains an indicator for whether the property element value is encrypted. The integer value has the following meanings: 0 specifies that the property value is not encrypted. 1 specifies that the property value is encrypted.

2.4.4.1.2.1.5.1 HttpConnectionPropertyNameEnum

The **HttpConnectionPropertyNameEnum** type contains the values for the **Name** attribute of the **Property** elements that are allowed for the [HttpConnectionType](#) complex type.

The following is the XSD for the **HttpConnectionPropertyNameEnum** type.

```
<xs:simpleType name="HttpConnectionPropertyNameEnum">
  <xs:restriction base="xs:string">
    <xs:enumeration value="ProxyPassword"/>
    <xs:enumeration value="ServerPassword"/>
  </xs:restriction>
</xs:simpleType>
```

The following table specifies the enumeration values for the **HttpConnectionPropertyNameEnum** type.

Enumeration value	Description
ServerPassword	Specifies a string value that contains the password to use on the server.
ProxyPassword	Specifies a string value that contains the password for the ProxyUserName account on the proxy server.

2.4.4.1.2.1.5.2 HttpConnectionAttributeGroup

The **HttpConnectionAttributeGroup** attribute group contains the attribute for the [HttpConnectionType](#) complex type.

The following is the XSD for the **HttpConnectionAttributeGroup** attribute group.

```
<xs:attributeGroup name="HttpConnectionAttributeGroup">
  <xs:attribute name="ServerURL" type="xs:string" use="required"
    form="qualified"/>
  <xs:attribute name="UseServerCredentials" type="DTS:BooleanStringCap"
    default="False" use="optional" form="qualified"/>
  <xs:attribute name="ServerUserName" type="xs:string" default=""
    use="optional" form="qualified"/>
</xs:attributeGroup>
```

```

<xs:attribute name="ServerDomain" type="xs:string" default=""
  use="optional" form="qualified"/>
<xs:attribute name="UseSecureConnection" type="DTS:BooleanStringCap"
  default="False" use="optional" form="qualified"/>
<xs:attribute name="CertificateIdentifier" type="xs:string" default=""
  use="optional" form="qualified"/>
<xs:attribute name="Certificate" type="xs:string" default=""
  use="optional" form="qualified"/>
<xs:attribute name="TimeOut" type="xs:int" default="60" use="optional"
  form="qualified"/>
<xs:attribute name="ChunkSize" type="xs:int" default="1" use="optional"
  form="qualified"/>
<xs:attribute name="UseProxy" type="DTS:BooleanStringCap"
  default="False" use="optional" form="qualified"/>
<xs:attribute name="ProxyURL" type="xs:string" default="" use="optional"
  form="qualified"/>
<xs:attribute name="BypassProxyOnLocal" type="DTS:BooleanStringCap"
  default="False" use="optional" form="qualified"/>
<xs:attribute name="UseProxyCredentials" type="DTS:BooleanStringCap"
  default="False" use="optional" form="qualified"/>
<xs:attribute name="ProxyUserName" type="xs:string" default=""
  use="optional" form="qualified"/>
<xs:attribute name="ProxyDomain" type="xs:string" default=""
  use="optional" form="qualified"/>
<xs:attribute name="BypassList" type="xs:string" default=""
  use="optional" form="qualified"/>
</xs:attributeGroup>

```

The following table specifies the attributes for the **HttpConnectionAttributeGroup** attribute group.

Enumeration value	Description
ServerURL	A string value that specifies the URL location of the HTTP server.
UseServerCredentials	A value of type DTS:BooleanStringCap that specifies an indicator for whether to use network credentials. "True" specifies that the connection uses server credentials. "False" specifies that the connection does not use server credentials.
ServerUserName	A string value that specifies the user name to use to log on to the server.
ServerDomain	A string value that specifies the domain name for the server.
UseSecureConnection	A value of type DTS:BooleanStringCap that specifies whether to use an HTTP or an HTTPS connection. "False" specifies to use the HTTP protocol. "True" specifies to use the HTTPS protocol.
CertificateIdentifier	A string value that specifies the X.509 RFC2459 certificate identifier.
TimeOut	An integer value that specifies the number of seconds after which the connection times out.
ChunkSize	An integer value that specifies the minimum number of bytes to read or write from the server.
UseProxy	A value of type DTS:BooleanStringCap that specifies whether to use a proxy

Enumeration value	Description
	server. "True" specifies that the connection uses a proxy server. "False" specifies that the connection does not use a proxy server.
ProxyURL	A string value that specifies the URL location of the proxy server.
BypassProxyOnLocal	A value of type DTS:BooleanStringCap that specifies whether to bypass a proxy server and use a local address instead. "True" specifies that the connection bypasses the proxy server for local addresses. "False" specifies that the connection does not bypass the proxy server for local addresses.
UseProxyCredentials	A value of type DTS:BooleanStringCap that specifies whether to use proxy credentials. "True" specifies that the connection uses proxy credentials. "False" specifies that the connection does not use proxy credentials.
ProxyUserName	A string value that specifies the name of the user to use to log on to the proxy server.
ProxyDomain	A string value that specifies the domain name for the proxy server.
BypassList	A string value that specifies a list of addresses that do not use the proxy server.

2.4.4.1.2.2 ConnectionManagerObjectDataMsmqConnectionManagerType

The **ConnectionManagerObjectDataMsmqConnectionManagerType** complex type is the type of the **MsmqConnectionManager** element that is a child of the **ObjectData** element when the type of the connection is to an MSMQ source.

The following is the XSD of the **ConnectionManagerObjectDataMsmqConnectionManagerType** complex type.

```
<xs:complexType
  name="ConnectionManagerObjectDataMsmqConnectionManagerType">
  <xs:sequence/>
  <xs:attribute name="ConnectionString" type="xs:string"
    form="unqualified"/>
</xs:complexType>
```

The **ConnectionManagerObjectDataMsmqConnectionManagerType** complex type MUST NOT contain any elements.

The following table specifies the attributes for the **ConnectionManagerObjectDataMsmqConnectionManagerType** complex type.

Attribute	Constraints	Description
ConnectionString	None	The connection string to an MSMQ source.

2.4.4.1.2.3 ConnectionManagerObjectDataSMOServerConnectionManagerType

The **ConnectionManagerObjectDataSMOServerConnectionManagerType** complex type is the type of the **SMOServerConnectionManager** element that is a child of the **ObjectData** element when the type of the connection is to a database that is using the Server Management Objects (SMO) object model for server management. <10>

The following is the XSD of the **ConnectionManagerObjectDataSMOServerConnectionManagerType** complex type.

```
<xs:complexType
  name="ConnectionManagerObjectDataSMOServerConnectionManagerType">
  <xs:sequence>
    <xs:element name="PassWord" type=
      "DTS>PasswordElementType"
      form="unqualified"/>
  </xs:sequence>
  <xs:attribute name="ConnectionString" type="xs:string"
    form="unqualified" use="required"/>
</xs:complexType>
```

The following tables specify the elements and attributes for the **ConnectionManagerObjectDataSMOServerConnectionManagerType** complex type.

Element	Constraints	Description
Password	None	The password for the connection to the SMO server source. The password can be encrypted, depending on the settings of the attribute values for the password element.

Attribute	Constraints	Description
ConnectionString	None	The connection string to an SMO server source.

2.4.4.1.2.4 ConnectionManagerObjectDataSmtplibConnectionManagerType

The **ConnectionManagerObjectDataSmtplibConnectionManagerType** complex type is the type of the **SmtplibConnectionManager** element, which is a child of the **ObjectData** element when the type of the connection is to an SMTP server.

The following is the XSD of the **ConnectionManagerObjectDataSmtplibConnectionManagerType** complex type.

```
<xs:complexType
  name="ConnectionManagerObjectDataSmtplibConnectionManagerType">
  <xs:sequence/>
  <xs:attribute name="ConnectionString" type="xs:string"
    form="unqualified"/>
</xs:complexType>
```

The **ConnectionManagerObjectDataSmtpConnectionManagerType** complex type MUST NOT contain any elements.

The following table specifies the attributes for the **ConnectionManagerObjectDataSmtpConnectionManagerType** complex type.

Attribute	Constraints	Description
ConnectionString	None	The connection string to an SMTP source.

2.4.4.1.2.5 ConnectionManagerObjectDataWmiConnectionManagerType

The **ConnectionManagerObjectDataWmiConnectionManagerType** complex type is the type of the **WmiConnectionManager** element, which is a child of the **ObjectData** element when the type of the connection is to a WMI data source.

The following is the XSD of the **ConnectionManagerObjectDataWmiConnectionManagerType** complex type.

```
<xs:complexType
  name="ConnectionManagerObjectDataWmiConnectionManagerType">
  <xs:sequence>
    <xs:element name="PassWord" minOccurs="0"
      type="DTS>PasswordElementType"
      form="unqualified"/>
  </xs:sequence>
  <xs:attribute name="ConnectionString" type="xs:string"
    form="unqualified"/>
</xs:complexType>
```

The following tables specify the elements and attributes for the **ConnectionManagerObjectDataSMOServerConnectionManagerType** complex type.

Attribute	Constraints	Description
ConnectionString	None	Specifies that the connection string is to a WMI data source.

2.4.4.1.3 ConnectionManagerObjectDataType Information for Data Sources

The type of data source that the connection manager specifies access for carries with it important constraints that are not fully expressed in the XSD code fragments. These additional constraints, which are explained in the subsections of this section, MUST be followed for each specific data source type. The important differences that vary by the data source type are the following:

- Allowed values for the **Name** attribute of the **Property** element within the **ObjectData** element can differ between different data sources. The same limitations apply to the **PropertyExpression** element within a **ConnectionManager** instance.
- The choice contained within the complex type definition for [ConnectionManagerObjectDataType](#) is also constrained by the type of data source. Not all of the choices in the XSD are available for each data source type.
- For those data sources that allow a **ConnectionManager** element to be contained by the **ObjectData** element, the choice that is contained within the complex type definition for the

ConnectionManager element of the **ConnectionManagerObjectDataType** is also constrained by the type of data source. Not all of the choices in the XSD are available for each data source type.

2.4.4.1.3.1 OLE DB Data Source

When the connection manager is to an OLE DB data source, the formal type of the **ObjectData** element is the [ConnectionManagerObjectDataType](#) type. However, the following XSD fragment, which is expressed as an anonymous complex type declaration, places further restrictions on the type from the restrictions that are declared in the formal type declaration. A **ConnectionManager** instance for an OLE DB source MUST follow the restrictions that are shown in this anonymous XSD fragment.

Note the following differences between this anonymous complex type declaration and the full definition of the complex type for the **ConnectionManagerObjectDataType** type:

- The value for the **CreationName** attribute of the containing **ConnectionManager** element MUST be "OLEDB".
- The **ObjectData** element type MUST be of the type that is specified by the anonymous XSD definition that is contained in this section.
- The **ObjectData** element MUST contain a **ConnectionManager** element.
- The **ConnectionManager** child element to the **ObjectData** element MUST NOT include attributes, except for those that are specified as valid in this anonymous XSD fragment, which is a subset of the attributes that are contained in the [ConnectionManagerConnectionManagerAttributeGroup](#) attribute group. The **PropertyExpression** element of the containing **ConnectionManager** element MUST NOT include properties, except for those that are named the same as the attributes for the **ConnectionManager** element in this anonymous type definition XSD fragment.

This anonymous type declaration acts as a replacement for the definition for **ConnectionManagerObjectDataType** type in the case of an OLE DB data source.

```
<xs:complexType>
  <xs:choice>
    <xs:element name="ConnectionManager">
      <xs:complexType>
        <xs:sequence/>
        <xs:attribute name="Retain" type="DTS:BooleanStringCap"
          default="False" use="optional" form="qualified"/>
        <xs:attribute name="ConnectionString" type="xs:string"
          use="required" form="qualified"/>
      </xs:complexType>
    </xs:element>
  </xs:choice>
</xs:complexType>
```

2.4.4.1.3.2 Flat File Data Source

When the connection manager is to a flat file data source, the formal type of the **ObjectData** element is the [ConnectionManagerObjectDataType](#) type. However, the following XSD fragment, which is expressed as an anonymous complex type declaration, places further restrictions on the type from the restrictions that are declared in the formal type declaration. A **ConnectionManager**

instance for a flat file data source MUST follow the restrictions that are shown in this anonymous XSD fragment.

Note the following differences between this anonymous complex type declaration and the full definition of the complex type for the **ConnectionManagerObjectDataType** type:

- The value for the **CreationName** attribute of the containing **ConnectionManager** element MUST be "FLATFILE".
- The **ObjectData** element type MUST be of the type that is specified by the anonymous XSD definition that is contained in this section.
- The **ObjectData** element MUST contain a **ConnectionManager** element.
- The **ConnectionManager** child element to the **ObjectData** element MUST NOT include attributes, except for those that are specified as valid in this anonymous XSD fragment, which is a subset of the attributes that are contained in the [ConnectionManagerConnectionManagerAttributeGroup](#) attribute group. The **PropertyExpression** element of the containing **ConnectionManager** element MUST NOT include properties, except for those that are named the same as the attributes for the **ConnectionManager** element in this anonymous type definition XSD fragment.
- The following attributes are required for a flat file data source and MUST be specified: **Format**, **HeaderRowDelimiter**, **RowDelimiter**, and **TextQualifier**.

This anonymous type declaration acts as a replacement for the definition for **ConnectionManagerObjectDataType** type in the case of a flat file data source.

```
<xs:complexType>
  <xs:choice>
    <xs:element name="ConnectionManager">
      <xs:complexType>
        <xs:sequence/>
        <xs:attribute name="ConnectionString" type="xs:string"
          use="required" form="qualified"/>
        <xs:attribute name="FileUsageType" type="DTS:FileUsageTypeEnum"
          default="0" use="optional" form="qualified"/>
        <xs:attribute name="Format" type="DTS:FormatEnum" use="required"
          form="qualified"/>
        <xs:attribute name="LocaleID" type="xs:int" use="optional"
          form="qualified"/>
        <xs:attribute name="Unicode" type="DTS:BooleanStringCap"
          default="False" use="optional" form="qualified"/>
        <xs:attribute name="HeaderRowsToSkip" type="xs:int" default="0"
          use="optional" form="qualified"/>
        <xs:attribute name="HeaderRowDelimiter" type="xs:string"
          use="required" form="qualified"/>
        <xs:attribute name="ColumnNamesInFirstDataRow" default="False"
          type="DTS:BooleanStringCap" use="optional"
          form="qualified"/>
        <xs:attribute name="RowDelimiter" type="xs:string" use="required"
          form="qualified"/>
        <xs:attribute name="DataRowsToSkip" type="xs:int" default="0"
          use="optional" form="qualified"/>
        <xs:attribute name="TextQualifier" type="xs:string" use="required"
          form="qualified"/>
        <xs:attribute name="CodePage" type="xs:int" use="optional"
```



```

        form="qualified"/>
    </xs:complexType>
</xs:element>
</xs:choice>
</xs:complexType>

```

2.4.4.1.3.3 ADO.NET Data Source

When the connection manager is to an ADO.NET data source, the formal type of the **ObjectData** element is the [ConnectionManagerObjectDataType](#) type. However, the following XSD fragment, which is expressed as an anonymous complex type declaration, places further restrictions on the type from the restrictions that are declared in the formal type declaration. A **ConnectionManager** instance for an ADO.NET source MUST follow the restrictions that are shown in this anonymous XSD fragment.

Note the following differences between this anonymous complex type declaration and the full definition of the complex type for the **ConnectionManagerObjectDataType** type:

- The value for the **CreationName** attribute of the containing **ConnectionManager** element MUST be "ADO.NET" concatenated together with the fully qualified name of a valid ADO.NET assembly.
- The **ObjectData** element type MUST be of the type that is specified by the anonymous XSD definition that is contained in this section.
- The **ObjectData** element MUST contain a **ConnectionManager** element.
- The **ConnectionManager** child element to the **ObjectData** element MUST NOT include attributes, except for those that are specified as valid in this anonymous XSD fragment, which is a subset of the attributes that are contained in the [ConnectionManagerConnectionManagerAttributeGroup](#) attribute group. The **PropertyExpression** element of the containing **ConnectionManager** element MUST NOT include properties, except for those that are named the same as the attributes for the **ConnectionManager** element in this anonymous type definition XSD fragment.

This anonymous type declaration acts as a replacement for the definition for **ConnectionManagerObjectDataType** type in the case of an ADO.NET data source.

```

<xs:complexType>
  <xs:choice>
    <xs:element name="ConnectionManager">
      <xs:complexType>
        <xs:sequence/>
        <xs:attribute name="Retain" type="DTS:BooleanStringCap"
          default="False" use="optional" form="qualified"/>
        <xs:attribute name="ConnectionString" type="xs:string"
          use="required" form="qualified"/>
        <xs:attribute name="ServerName" type="xs:string" use="required"
          form="qualified"/>
      </xs:complexType>
    </xs:element>
  </xs:choice>
</xs:complexType>

```

2.4.4.1.3.4 Analysis Services Data Source

When the connection manager is to an Analysis Services data source, the formal type of the **ObjectData** element is the [ConnectionManagerObjectDataType](#) type. However, the following XSD fragment, which is expressed as an anonymous complex type declaration, places further restrictions on the type from the restrictions that are declared in the formal type declaration. A **ConnectionManager** instance for an Analysis Services source MUST follow the restrictions that are shown in this anonymous XSD fragment.

Note the following differences between this anonymous complex type declaration and the full definition of the complex type for the **ConnectionManagerObjectDataType** type:

- The value for the **CreationName** attribute of the containing **ConnectionManager** element MUST be "MSOLAP100".
- The **ObjectData** element type MUST be of the type that is specified by the anonymous XSD definition that is contained in this section.
- The **ObjectData** element MUST contain a **ConnectionManager** element.
- The **ConnectionManager** child element to the **ObjectData** element MUST NOT include attributes, except for those that are specified as valid in this anonymous XSD fragment, which is a subset of the attributes that are contained in the [ConnectionManagerConnectionManagerAttributeGroup](#) attribute group. The **PropertyExpression** element of the containing **ConnectionManager** element MUST NOT include properties, except for those that are named the same as the attributes for the **ConnectionManager** element in this anonymous type definition XSD fragment.

This anonymous type declaration acts as a replacement for the definition for **ConnectionManagerObjectDataType** type in the case of an Analysis Services data source.

```
<xs:complexType>
  <xs:choice>
    <xs:element name="ConnectionManager">
      <xs:complexType>
        <xs:sequence/>
        <xs:attribute name="Retain" type="DTS:BooleanStringCap"
          default="False" use="optional" form="qualified"/>
        <xs:attribute name="ConnectionString" type="xs:string"
          use="required" form="qualified"/>
      </xs:complexType>
    </xs:element>
  </xs:choice>
</xs:complexType>
```

2.4.4.1.3.5 File Data Source

When the connection manager is to a File data source, the formal type of the **ObjectData** element is the [ConnectionManagerObjectDataType](#) type. However, the following XSD fragment, which is expressed as an anonymous complex type declaration, places further restrictions on the type from the restrictions that are declared in the formal type declaration. A **ConnectionManager** instance for a File source MUST follow the restrictions that are shown in this anonymous XSD fragment.

Note the following differences between this anonymous complex type declaration and the full definition of the complex type for the **ConnectionManagerObjectDataType** type:

- The value for the **CreationName** attribute of the containing **ConnectionManager** element MUST be "FILE".
- The **ObjectData** element type MUST be of the type that is specified by the anonymous XSD definition that is contained in this section.
- The **ObjectData** element MUST contain a **ConnectionManager** element.
- The **ConnectionManager** child element to the **ObjectData** element MUST NOT include attributes, except for those that are specified as valid in this anonymous XSD fragment, which is a subset of the attributes that are contained in the [ConnectionManagerConnectionManagerAttributeGroup](#) attribute group. The **PropertyExpression** element of the containing **ConnectionManager** element MUST NOT include properties, except for those that are named the same as the attributes for the **ConnectionManager** element in this anonymous type definition XSD fragment.

This anonymous type declaration acts as a replacement for the definition for **ConnectionManagerObjectDataType** type in the case of a File data source.

```
<xs:complexType>
  <xs:choice>
    <xs:element name="ConnectionManager">
      <xs:complexType>
        <xs:sequence/>
        <xs:attribute name="ConnectionString" type="xs:string"
          use="required" form="qualified"/>
        <xs:attribute name="FileUsageType" type="DTS:FileUsageTypeEnum"
          default="0" use="optional" form="qualified"/>
      </xs:complexType>
    </xs:element>
  </xs:choice>
</xs:complexType>
```

2.4.4.1.3.6 Cache Data Source

When the connection manager is to a Cache data source, the formal type of the **ObjectData** element is the [ConnectionManagerObjectDataType](#) type. However, the following XSD fragment, which is expressed as an anonymous complex type declaration, places further restrictions on the type from the restrictions that are declared in the formal type declaration. A **ConnectionManager** instance for a Cache source MUST follow the restrictions that are shown in this anonymous XSD fragment.

Note the following differences between this anonymous complex type declaration and the full definition of the complex type for the **ConnectionManagerObjectDataType** type:

- The value for the **CreationName** attribute of the containing **ConnectionManager** element MUST be "CACHE".
- The **ObjectData** element type MUST be of the type that is specified by the anonymous XSD definition that is contained in this section.
- The **ObjectData** element MUST contain a **ConnectionManager** element.
- The **ConnectionManager** child element to the **ObjectData** element MUST NOT include attributes, except for those that are specified as valid in this anonymous XSD fragment, which is

a subset of the attributes that are contained in the [ConnectionManagerConnectionManagerAttributeGroup](#) attribute group. The **PropertyExpression** element of the containing **ConnectionManager** element MUST NOT include properties, except for those that are named the same as the attributes for the **ConnectionManager** element in this anonymous type definition XSD fragment.

This anonymous type declaration acts as a replacement for the definition for **ConnectionManagerObjectDataType** type in the case of a Cache data source.

```
<xs:complexType>
  <xs:choice>
    <xs:element name="ConnectionManager">
      <xs:complexType>
        <xs:sequence/>
        <xs:attribute name="UseFile" type="DTS:BooleanStringCap"
          default="False" use="optional" form="qualified"/>
        <xs:attribute name="UseEncryption" type="DTS:BooleanStringCap"
          default="False" use="optional" form="qualified"/>
        <xs:attribute name="RetainData" type="DTS:BooleanStringCap"
          default="True" use="optional" form="qualified"/>
      </xs:complexType>
    </xs:element>
  </xs:choice>
</xs:complexType>
```

2.4.4.1.3.7 Excel Data Source

When the connection manager is to an Excel data source, the formal type of the **ObjectData** element is the [ConnectionManagerObjectDataType](#) type. However, the following XSD fragment, which is expressed as an anonymous complex type declaration, places further restrictions on the type from the restrictions that are declared in the formal type declaration. A **ConnectionManager** instance for an Excel source MUST follow the restrictions that are shown in this anonymous XSD fragment.

Note the following differences between this anonymous complex type declaration and the full definition of the complex type for the **ConnectionManagerObjectDataType** type:

- The value for the **CreationName** attribute of the containing **ConnectionManager** element MUST be "EXCEL".
- The **ObjectData** element type MUST be of the type that is specified by the anonymous XSD definition that is contained in this section.
- The **ObjectData** element MUST contain a **ConnectionManager** element.
- The **ConnectionManager** child element to the **ObjectData** element MUST NOT include attributes, except for those that are specified as valid in this anonymous XSD fragment, which is a subset of the attributes that are contained in the [ConnectionManagerConnectionManagerAttributeGroup](#) attribute group. The **PropertyExpression** element of the containing **ConnectionManager** element MUST NOT include properties, except for those that are named the same as the attributes for the **ConnectionManager** element in this anonymous type definition XSD fragment.

This anonymous type declaration acts as a replacement for the definition for **ConnectionManagerObjectDataType** type in the case of an Excel data source.

```

<xs:complexType>
  <xs:choice>
    <xs:element name="ConnectionManager">
      <xs:complexType>
        <xs:sequence/>
        <xs:attribute name="Retain" type="DTS:BooleanStringCap"
          default="False" use="optional" form="qualified"/>
        <xs:attribute name="ConnectionString" type="xs:string"
          use="required" form="qualified"/>
      </xs:complexType>
    </xs:element>
  </xs:choice>
</xs:complexType>

```

2.4.4.1.3.8 FTP Data Source

When the connection manager is to an FTP data source, the formal type of the **ObjectData** element is the [ConnectionManagerObjectDataType](#) type. However, the following XSD fragment, which is expressed as an anonymous complex type declaration, places further restrictions on the type from the restrictions that are declared in the formal type declaration. A **ConnectionManager** instance for an FTP source MUST follow the restrictions that are shown in this anonymous XSD fragment.

Note the following differences between this anonymous complex type declaration and the full definition of the complex type for the **ConnectionManagerObjectDataType** type:

- The value for the **CreationName** attribute of the containing **ConnectionManager** element MUST be "FTP".
- The **ObjectData** element type MUST be of the type that is specified by the anonymous XSD definition that is contained in this section.
- The **ObjectData** element MUST contain a **ConnectionManager** element.
- The **ConnectionManager** child element to the **ObjectData** element MUST NOT include attributes, except for those that are specified as valid in this anonymous XSD fragment, which is a subset of the attributes that are contained in the [ConnectionManagerConnectionManagerAttributeGroup](#) attribute group. The **PropertyExpression** element of the containing **ConnectionManager** element MUST NOT include properties, except for those that are named the same as the attributes for the **ConnectionManager** element in this anonymous type definition XSD fragment.

This anonymous type declaration acts as a replacement for the definition for **ConnectionManagerObjectDataType** type in the case of an FTP data source.

```

<xs:complexType>
  <xs:choice>
    <xs:element name="ConnectionManager">
      <xs:complexType>
        <xs:sequence/>
        <xs:attribute name="ConnectionString" type="xs:string"
          use="required" form="qualified"/>
      </xs:complexType>
    </xs:element>
  </xs:choice>

```

```
</xs:complexType>
```

2.4.4.1.3.9 HTTP Data Source

When the connection manager is to an HTTP data source, the formal type of the **ObjectData** element is the [ConnectionManagerObjectDataType](#) type. However, the following XSD fragment, which is expressed as an anonymous complex type declaration, places further restrictions on the type from the restrictions that are declared in the formal type declaration. A **ConnectionManager** instance for an HTTP data source MUST follow the restrictions that are shown in this anonymous XSD fragment.

Note the following differences between this anonymous complex type declaration and the full definition of the complex type for the **ConnectionManagerObjectDataType** type:

- The value for the **CreationName** attribute of the containing **ConnectionManager** element MUST be "HTTP".
- The **ObjectData** element type MUST be of the type that is specified by the anonymous XSD definition that is contained in this section.
- The **ObjectData** element MUST contain a **ConnectionManager** element.
- The **ConnectionManager** child element to the **ObjectData** element MUST NOT include attributes, except for those that are specified as valid in this anonymous XSD fragment, which is a subset of the attributes that are contained in the [ConnectionManagerConnectionManagerAttributeGroup](#) attribute group. The **PropertyExpression** element of the containing **ConnectionManager** element MUST NOT include properties, except for those that are named the same as the attributes for the **ConnectionManager** element in this anonymous type definition XSD fragment.

This anonymous type declaration acts as a replacement for the definition for **ConnectionManagerObjectDataType** type in the case of an HTTP data source.

```
<xs:complexType>
  <xs:choice>
    <xs:element name="ConnectionManager">
      <xs:complexType>
        <xs:sequence/>
        <xs:attribute name="ConnectionString" type="xs:string"
          use="required" form="qualified"/>
      </xs:complexType>
    </xs:element>
  </xs:choice>
</xs:complexType>
```

2.4.4.1.3.10 MSMQ Data Source

When the connection manager is to an MSMQ data source, the formal type of the **ObjectData** element is the [ConnectionManagerObjectDataType](#) type. However, the following XSD fragment, which is expressed as an anonymous complex type declaration, places further restrictions on the type than the restrictions that are declared in the formal type declaration. A **ConnectionManager** instance to an MSMQ data source MUST follow the restrictions that are shown in this anonymous XSD fragment.

Note the following differences between this anonymous complex type declaration and the full definition of the complex type for the **ConnectionManagerObjectDataType** type:

- The value for the **CreationName Property** of the containing **ConnectionManager** element MUST be "MSMQ".
- The **ObjectData** element type MUST be of the type that is specified by the anonymous XSD definition that is contained in this section.
- The **ObjectData** element MUST contain an **MsmqConnectionManager** element of type [ConnectionManagerObjectDataMsmqConnectionManagerType](#).

This anonymous type declaration acts as a replacement for the definition for **ConnectionManagerObjectDataType** type in the case of an MSMQ data source.

```
<xs:complexType>
  <xs:choice>
    <xs:element name="MsmqConnectionManager"
      type="DTS:ConnectionManagerObjectDataMsmqConnectionManagerType"/>
  </xs:choice>
</xs:complexType>
```

2.4.4.1.3.11 MULTIFILE Data Source

When the connection manager is to a multiple file data source, the formal type of the **ObjectData** element is the [ConnectionManagerObjectDataType](#) type. However, the following XSD fragment, which is expressed as an anonymous complex type declaration, places further restrictions on the type from the restrictions that are declared in the formal type declaration. A **ConnectionManager** instance for a multiple file source MUST follow the restrictions that are shown in this anonymous XSD fragment.

Note the following differences between this anonymous complex type declaration and the full definition of the complex type for the **ConnectionManagerObjectDataType** type:

- The value for the **CreationName** attribute of the containing **ConnectionManager** element MUST be "MULTIFILE".
- The **ObjectData** element type MUST be of the type that is specified by the anonymous XSD definition that is contained in this section.
- The **ObjectData** element MUST contain a **ConnectionManager** element.
- The **ConnectionManager** child element to the **ObjectData** element MUST NOT include attributes, except for those that are specified as valid in this anonymous XSD fragment, which is a subset of the attributes that are contained in the [ConnectionManagerConnectionManagerAttributeGroup](#) attribute group. The **PropertyExpression** element of the containing **ConnectionManager** element MUST NOT include properties, except for those that are named the same as the attributes for the **ConnectionManager** element in this anonymous type definition XSD fragment.

This anonymous type declaration acts as a replacement for the definition for **ConnectionManagerObjectDataType** type in the case of a multiple file data source.

```
<xs:complexType>
```

```

<xs:choice>
  <xs:element name="ConnectionManager">
    <xs:complexType>
      <xs:sequence/>
      <xs:attribute name="ConnectionString" type="xs:string"
        use="required" form="qualified"/>
      <xs:attribute name="FileUsageType" type="DTS:FileUsageTypeEnum"
        default="0" use="optional" form="qualified"/>
    </xs:complexType>
  </xs:element>
</xs:choice>
</xs:complexType>

```

2.4.4.1.3.12 MULTIFLATFILE Data Source

When the connection manager is to a multiple flat file data source, the formal type of the **ObjectData** element is the [ConnectionManagerObjectDataType](#) type. However, the following XSD fragment, which is expressed as an anonymous complex type declaration, places further restrictions on the type from the restrictions that are declared in the formal type declaration. A **ConnectionManager** instance for a multiple flat file source MUST follow the restrictions that are shown in this anonymous XSD fragment.

Note the following differences between this anonymous complex type declaration and the full definition of the complex type for the **ConnectionManagerObjectDataType** type:

- The value for the **CreationName** attribute of the containing **ConnectionManager** element MUST be "MULTIFLATFILE".
- The **ObjectData** element type MUST be of the type that is specified by the anonymous XSD definition that is contained in this section.
- The **ObjectData** element MUST contain a **ConnectionManager** element.
- The **ConnectionManager** child element to the **ObjectData** element MUST NOT include attributes, except for those that are specified as valid in this anonymous XSD fragment, which is a subset of the attributes that are contained in the [ConnectionManagerConnectionManagerAttributeGroup](#) attribute group. The **PropertyExpression** element of the containing **ConnectionManager** element MUST NOT include properties, except for those that are named the same as the attributes for the **ConnectionManager** element in this anonymous type definition XSD fragment.

This anonymous type declaration acts as a replacement for the definition for **ConnectionManagerObjectDataType** type in the case of a multiple flat file data source.

```

<xs:complexType>
  <xs:choice>
    <xs:element name="ConnectionManager">
      <xs:complexType>
        <xs:sequence/>
        <xs:attribute name="ConnectionString" type="xs:string"
          use="required" form="qualified"/>
        <xs:attribute name="FileUsageType" type="DTS:FileUsageTypeEnum"
          default="0" use="optional" form="qualified"/>
      </xs:complexType>
    </xs:element>
  </xs:choice>
</xs:complexType>

```



```
</xs:choice>
</xs:complexType>
```

2.4.4.1.3.13 ODBC Data Source

When the connection manager is to an ODBC data source, the formal type of the **ObjectData** element is the [ConnectionManagerObjectDataType](#) type. However, the following XSD fragment, which is expressed as an anonymous complex type declaration, places further restrictions on the type from the restrictions that are declared in the formal type declaration. A **ConnectionManager** instance for an ODBC source MUST follow the restrictions that are shown in this anonymous XSD fragment.

Note the following differences between this anonymous complex type declaration and the full definition of the complex type for the **ConnectionManagerObjectDataType** type:

- The value for the **CreationName** attribute of the containing **ConnectionManager** element MUST be "ODBC".
- The **ObjectData** element type MUST be of the type that is specified by the anonymous XSD definition that is contained in this section.
- The **ObjectData** element MUST contain a **ConnectionManager** element.
- The **ConnectionManager** child element to the **ObjectData** element MUST NOT include attributes, except for those that are specified as valid in this anonymous XSD fragment, which is a subset of the attributes that are contained in the [ConnectionManagerConnectionManagerAttributeGroup](#) attribute group. The **PropertyExpression** element of the containing **ConnectionManager** element MUST NOT include properties, except for those that are named the same as the attributes for the **ConnectionManager** element in this anonymous type definition XSD fragment.

This anonymous type declaration acts as a replacement for the definition for **ConnectionManagerObjectDataType** type in the case of an ODBC data source.

```
<xs:complexType>
  <xs:choice>
    <xs:element name="ConnectionManager">
      <xs:complexType>
        <xs:sequence/>
        <xs:attribute name="Retain" type="DTS:BooleanStringCap"
          default="False" use="optional" form="qualified"/>
        <xs:attribute name="ConnectionString" type="xs:string"
          use="required" form="qualified"/>
        <xs:attribute name="ServerName" type="xs:string" use="required"
          form="qualified"/>
      </xs:complexType>
    </xs:element>
  </xs:choice>
</xs:complexType>
```

2.4.4.1.3.14 SMOServer Data Source

When the connection manager is to an SMOServer data source, the formal type of the **ObjectData** element is the [ConnectionManagerObjectDataType](#) type. However, the following XSD fragment,

which is expressed as an anonymous complex type declaration, places further restrictions on the type than the restrictions that are declared in the formal type declaration. A **ConnectionManager** instance to an SMOServer source MUST follow the restrictions that are shown in this anonymous XSD fragment.

Note the following differences between this anonymous complex type declaration and the full definition of the complex type for the **ConnectionManagerObjectDataType** type:

- The value for the **CreationName Property** of the containing **ConnectionManager** element MUST be "SMOServer".
- The **ObjectData** element type MUST be of the type that is specified by the anonymous XSD definition that is contained in this section.
- The **ObjectData** element MUST contain an **SMOServerConnectionManager** element of type [ConnectionManagerObjectDataSMOServerConnectionManagerType](#).

This anonymous type declaration acts as a replacement for the definition for **ConnectionManagerObjectDataType** type in the case of an SMOServer data source.

```
<xs:complexType>
  <xs:choice>
    <xs:element name="SMOServerConnectionManager"
      type="DTS:ConnectionManagerObjectDataSMOServerConnectionManagerType"/>
  </xs:choice>
</xs:complexType>
```

2.4.4.1.3.15 SMTP Data Source

When the connection manager is to an SMTP data source, the formal type of the **ObjectData** element is the [ConnectionManagerObjectDataType](#) type. However, the following XSD fragment, which is expressed as an anonymous complex type declaration, places further restrictions on the type than the restrictions that are declared in the formal type declaration. A **ConnectionManager** instance to an SMTP data source MUST follow the restrictions that are shown in this anonymous XSD fragment.

Note the following differences between this anonymous complex type declaration and the full definition of the complex type for the **ConnectionManagerObjectDataType** type:

- The value for the **CreationName Property** of the containing **ConnectionManager** element MUST be "SMOServer".
- The **ObjectData** element type MUST be of the type that is specified by the anonymous XSD definition that is contained in this section.
- The **ObjectData** element MUST contain an **SmtplibConnectionManager** element of type [ConnectionManagerObjectDataSmtplibConnectionManagerType](#).

This anonymous type declaration acts as a replacement for the definition for **ConnectionManagerObjectDataType** type in the case of an SMTP data source.

```
<xs:complexType>
  <xs:choice>
    <xs:element name="SmtplibConnectionManager"
      type="DTS:ConnectionManagerObjectDataSmtplibConnectionManagerType"/>
  </xs:choice>
</xs:complexType>
```

```

        type="DTS:ConnectionManagerObjectDataSmtpConnectionManagerType"/>
    </xs:choice>
</xs:complexType>

```

2.4.4.1.3.16 SQLMOBILE Data Source

When the connection manager is to a Microsoft® SQL Server® Mobile data source, the formal type of the **ObjectData** element is the [ConnectionManagerObjectDataType](#) type. However, the following XSD fragment, which is expressed as an anonymous complex type declaration, places further restrictions on the type from the restrictions that are declared in the formal type declaration. A **ConnectionManager** instance for a SQL Server Mobile source MUST follow the restrictions that are shown in this anonymous XSD fragment.

Note the following differences between this anonymous complex type declaration and the full definition of the complex type for the **ConnectionManagerObjectDataType** type:

- The value for the **CreationName** attribute of the containing **ConnectionManager** element MUST be "SQLMOBILE".
- The **ObjectData** element type MUST be of the type that is specified by the anonymous XSD definition that is contained in this section.
- The **ObjectData** element MUST contain a **ConnectionManager** element.
- The **ConnectionManager** child element to the **ObjectData** element MUST NOT include attributes, except for those that are specified as valid in this anonymous XSD fragment, which is a subset of the attributes that are contained in the [ConnectionManagerConnectionManagerAttributeGroup](#) attribute group. The **PropertyExpression** element of the containing **ConnectionManager** element MUST NOT include properties, except for those that are named the same as the attributes for the **ConnectionManager** element in this anonymous type definition XSD fragment.

This anonymous type declaration acts as a replacement for the definition for **ConnectionManagerObjectDataType** type in the case of a SQL Server Mobile data source.

```

<xs:complexType>
  <xs:choice>
    <xs:element name="ConnectionManager">
      <xs:complexType>
        <xs:sequence/>
        <xs:attribute name="ConnectionString" type="xs:string"
          use="required" form="qualified"/>
      </xs:complexType>
    </xs:element>
  </xs:choice>
</xs:complexType>

```

2.4.4.1.3.17 WMI Data Source

When the connection manager is to a WMI data source, the formal type of the **ObjectData** element is the [ConnectionManagerObjectDataType](#) type. However, the following XSD fragment, which is expressed as an anonymous complex type declaration, places further restrictions on the type than

the restrictions that are declared in the formal type declaration. A **ConnectionManager** instance to a WMI data source MUST follow the restrictions that are shown in this anonymous XSD fragment.

Note the following differences between this anonymous complex type declaration and the full definition of the complex type for the **ConnectionManagerObjectDataType** type:

- The value for the **CreationName Property** of the containing **ConnectionManager** element MUST be "WMI".
- The **ObjectData** element type MUST be of the type that is specified by the anonymous XSD definition that is contained in this section.
- The **ObjectData** element MUST contain a **WmiConnectionManager** element of type [ConnectionManagerObjectDataWmiConnectionManagerType](#).

This anonymous type declaration acts as a replacement for the definition for **ConnectionManagerObjectDataType** type in the case of a WMI data source.

```
<xs:complexType>
  <xs:choice>
    <xs:element name="WmiConnectionManager"
      type="DTS:ConnectionManagerObjectDataWmiConnectionManagerType"/>
  </xs:choice>
</xs:complexType>
```

2.4.5 ExecutableTypePackagePropertyNameEnum

The **ExecutableTypePackagePropertyNameEnum** type contains the values for the **Name** attribute of the property elements that are allowed for executable type [ExecutableTypePackage](#). The **ExecutableTypePackagePropertyNameEnum** type is a union of the enumeration for the **AllExecutablePropertyNameEnum** type with the additional values that are specified in this section.

The following is the XSD for the **ExecutableTypePackagePropertyNameEnum** type.

```
<xs:simpleType name="ExecutableTypePackagePropertyNameEnum">
  <xs:restriction base="xs:string">
    <xs:enumeration value="PackageFormatVersion"/>
  </xs:restriction>
</xs:simpleType>
```

The following table specifies the enumeration values for the **ExecutableTypePackagePropertyNameEnum** type.

Property name	Description
PackageFormatVersion	Specifies the package format version.

2.4.6 ExecutableTypePackageAttributeGroup

The **ExecutableTypePackageAttributeGroup** attribute group contains the attributes for the [ExecutableTypePackage](#) type.

The following is the XSD for the **ExecutableTypePackageAttributeGroup** attribute group.

```
<xs:attributeGroup name="ExecutableTypePackageAttributeGroup">
  <xs:attribute name="VersionComments" type="xs:string" default=""
    use="optional" form="qualified"/>
  <xs:attribute name="CreatorName" type="xs:string" use="optional"
    form="qualified"/>
  <xs:attribute name="CreatorComputerName" type="xs:string"
    use="optional" form="qualified"/>
  <xs:attribute name="CreationDate" type="xs:dateTime" use="optional"
    form="qualified"/>
  <xs:attribute name="PackageType" type="DTS:PackageTypeEnum" default="0"
    use="optional" form="qualified"/>
  <xs:attribute name="ProtectionLevel" type="DTS:ProtectionLevelEnum"
    default="1" use="optional" form="qualified"/>
  <xs:attribute name="MaxConcurrentExecutables" type="xs:int"
    default="-1" use="optional" form="qualified"/>
  <xs:attribute name="PackagePriorityClass" default="0" use="optional"
    type="DTS:PackagePriorityClassEnum" form="qualified"/>
  <xs:attribute name="VersionMajor" type="xs:int" default="1"
    use="optional" form="qualified"/>
  <xs:attribute name="VersionMinor" type="xs:int" default="0"
    use="optional" form="qualified"/>
  <xs:attribute name="VersionBuild" type="xs:int" default="0"
    use="optional" form="qualified"/>
  <xs:attribute name="VersionGUID" type="DTS:uuid" use="optional"
    form="qualified"/>
  <xs:attribute name="EnableConfig" type="DTS:BooleanStringCap"
    default="False" use="optional" form="qualified"/>
  <xs:attribute name="CheckpointFileName" type="xs:string" default=""
    use="optional" form="qualified"/>
  <xs:attribute name="SaveCheckpoints" type="DTS:BooleanStringCap"
    default="False" use="optional" form="qualified"/>
  <xs:attribute name="CheckpointUsage" type="DTS:CheckpointUsageEnum"
    default="0" use="optional" form="qualified"/>
  <xs:attribute name="SuppressConfigurationWarnings" default="False"
    type="DTS:BooleanStringCap" use="optional"
    form="qualified"/>
  <xs:attribute name="LastModifiedProductVersion" type="xs:string"
    use="optional" form="qualified"/>
</xs:attributeGroup>
```

The following table specifies the attributes for the **ExecutableTypePackageAttributeGroup** attribute group.

Attribute	Description
VersionComments	A string value that specifies text that can be used to store comments about the version. <11>
CreatorName	A string value that specifies text that can be used to store the creator name of the package as documentation. <12>
CreatorComputerName	A string value that specifies text that serves as documentation of the computer on which the package was created. <13>

Attribute	Description
CreationDate	A date/time value that specifies the date that the executable was created. <14>
PackageType	An enumeration value that specifies how the package was created. <15>
ProtectionLevel	An enumeration value that specifies how sensitive information is saved with packages.
MaxConcurrentExecutables	An integer value that specifies the maximum number of executables to execute concurrently in the package. Valid values are -1 and any integer greater than or equal to 1. A value of -1 allows the maximum number of concurrently running executables to equal the number of processors plus two.
PackagePriorityClass	An enumeration value that specifies the execution priority of the package.
VersionMajor	An integer value that specifies the major version of the package. Valid values are integers greater than or equal to 0.
VersionMinor	An integer value that specifies the minor version of the package. Valid values are integers greater than or equal to 0.
VersionBuild	An integer value that specifies the build number of the package. Valid values are integers greater than or equal to 0. <16>
VersionGUID	A value of type DTS:uuid that specifies the globally unique identifier (GUID) of the package version. <17>
EnableConfig	A value of type DTS:BooleanStringCap that specifies whether settings from external configuration settings are accessible to the executable. "True" specifies that configurations are used with the package. "False" specifies that configurations are not used with the package.
CheckpointFileName	A string value that specifies the name of a checkpoint file that a checkpoint-enabled package uses.
SaveCheckpoints	A value of type DTS:BooleanStringCap that specifies whether the package saves checkpoints. "True" specifies that saving of checkpoints is enabled. "False" specifies that saving of checkpoints is not enabled.
CheckpointUsage	An enumeration value that specifies when the package uses checkpoints.
SuppressConfigurationWarnings	A value of type DTS:BooleanStringCap that specifies whether configuration warnings are suppressed. "True" specifies that configuration warnings are suppressed. "False" specifies that configuration warnings are not suppressed.
LastModifiedProductVersion	A string value that specifies the latest version of the product that is installed. <18>

2.4.6.1 PackageTypeEnum

The **PackageTypeEnum** type contains the enumeration values that specify how the package was created.

The following is the XSD of the **PackageTypeEnum** type.

```
<xs:simpleType name="PackageTypeEnum">
  <xs:restriction base="xs:int">
    <xs:minInclusive value="0"/>
    <xs:maxInclusive value="6"/>
  </xs:restriction>
</xs:simpleType>
```

The following table specifies the descriptions for the enumeration values of the **PackageTypeEnum** type.

Enumeration value	Description
0	Default
1	DTS Wizard
2	DTS Designer
3	SQL Replication
5	DTS Designer 100
6	SQL DB Maintenance

2.4.6.2 ProtectionLevelEnum

The **ProtectionLevelEnum** type contains the enumeration values that specify how sensitive information is saved with the package.

The following is the XSD of the **ProtectionLevelEnum** type.

```
<xs:simpleType name="ProtectionLevelEnum">
  <xs:restriction base="xs:int">
    <xs:minInclusive value="0"/>
    <xs:maxInclusive value="5"/>
  </xs:restriction>
</xs:simpleType>
```

The following table specifies the descriptions for the enumeration values of the **ProtectionLevelEnum** type.

Enumeration value	Description
0	Do not save sensitive information.
1	Encrypt sensitive information with user key.

Enumeration value	Description
2	Encrypt sensitive information with password.
3	Encrypt all information with password.
4	Encrypt all information with user key.
5	Use server storage.

2.4.6.3 PackagePriorityClassEnum

The **PackagePriorityClassEnum** type contains the enumeration values that specify how sensitive information is saved with the package.

The following is the XSD of the **PackagePriorityClassEnum** type.

```
<xs:simpleType name="PackagePriorityClassEnum">
  <xs:restriction base="xs:int">
    <xs:minInclusive value="0"/>
    <xs:maxInclusive value="4"/>
  </xs:restriction>
</xs:simpleType>
```

The following table specifies the descriptions for the enumeration values of the **PackagePriorityClassEnum** type.

Enumeration value	Priority for package
0	Default
1	Above normal
2	Normal
3	Below normal
4	Idle

2.4.6.4 CheckpointUsageEnum

The **CheckpointUsageEnum** type contains the enumeration values that specify when the package uses checkpoints.

The following is the XSD of the **CheckpointUsageEnum** type.

```
<xs:simpleType name="CheckpointUsageEnum">
  <xs:restriction base="xs:int">
    <xs:minInclusive value="0"/>
    <xs:maxInclusive value="2"/>
  </xs:restriction>
</xs:simpleType>
```

The following table specifies the descriptions for the enumeration values of the **CheckpointUsageEnum** type.

Enumeration value	Description
0	Never use checkpoints.
1	Use checkpoints if they exist.
2	Always use checkpoints.

2.4.7 PackageParametersType

The **PackageParametersType** complex type is the container type for a collection of elements of type [PackageParameterType](#).

The following is the XSD of the **PackageParametersType** type.

```
<xs:complexType name="PackageParametersType">
  <xs:sequence>
    <xs:element name="PackageParameter" type="DTS:PackageParameterType" minOccurs="0"
maxOccurs="unbounded" />
  </xs:sequence>
</xs:complexType>
```

The following table provides additional information about the elements, types, and constraints for the **PackageParametersType** complex type.

Element	Type definition	Description
PackageParameter	PackageParameterType	Specifies a PackageParameter element that contains the values and content for a package parameter.

2.4.7.1 PackageParameterType

The **PackageParameterType** complex type is used to specify **package parameters**.

The following is the XSD for the **PackageParameterType** complex type.

```
<xs:complexType name="PackageParameterType">
  <xs:sequence>
    <xs:element maxOccurs="unbounded" name="Property"
type="DTS:PackageParameterPropertyType" />
  </xs:sequence>
  <xs:attribute name="CreationName" use="required" type="xs:string" />
  <xs:attribute name="DataType" type="xs:unsignedByte" use="required" />
  <xs:attribute name="Description" type="xs:string" use="optional" />
  <xs:attribute name="DTSID" type="DTS:uuid" use="required" />
  <xs:attribute name="ObjectName" type="xs:string" use="required" />
  <xs:attribute name="Required" type="xs:string" use="optional" />
  <xs:attribute name="Sensitive" type="xs:string" use="optional" />
</xs:complexType>
```

The following table provides additional information about the attributes of the **PackageParameterType** type.

Attribute	Constraints	Description
CreationName	SHOULD be empty.	This attribute is ignored.
DataType	MUST be an integer value from the following table.	Specifies the data type of the parameter.
Description	None.	A description of the parameter.
DTSID	None.	A UUID that uniquely identifies the package parameter.
ObjectName	MUST be a valid name.	The name of the parameter.
Required	The value of this attribute MUST be either the string literal True or the string literal False.	If present and having the value True, the parameter is declared to be a required parameter.
Sensitive	The value of this attribute MUST be either the string literal True or the string literal False.	If present and having the value True, the parameter is declared to be a sensitive parameter

The following table lists the allowable values for the **DataType** attribute and the data types that correspond to those values.

Integer value	Corresponding data type in the Microsoft® .NET Framework
2	Int16
3	Int32
4	Single
5	Double
7	DateTime
8	String
11	Boolean
14	Decimal
16	SByte
17	Byte
19	UInt32
20	Int64
21	UInt64

2.4.7.2 PackageParameterPropertyType

The **PackageParameterPropertyType** complex type is used to specify the properties of package parameters. In particular, the value of a non-sensitive parameter is stored in a property child element of the **PackageParameter** element representing that parameter.

The following is the XSD for the **PackageParameterPropertyType** complex type

```
<xs:complexType mixed="true" name="PackageParameterPropertyType">
  <xs:sequence minOccurs="0">
    <xs:element name="Property"
type="DTS:PackageParameterPropertyEncryptedValuePropertyType" />
  </xs:sequence>
  <xs:attribute name="DataType" type="xs:unsignedByte" use="optional" />
  <xs:attribute name="Name" type="xs:string" use="required" />
</xs:complexType>
```

The following table provides additional information about the attributes of the **PackageParameterPropertyType**.

Attribute	Constraints	Description
DataType	If present, MUST be the same as the value of the DataType attribute of the PackageParameterType element that contains the PackageParameterPropertyType element. MUST be present when the Sensitive attribute of the PackageParameterType element that contains the PackageParameterPropertyType element is not present or has the value False. Must not be present when the value of that attribute is True.	Specifies the data type of the property.
Name	MUST be the value DefaultValue.	Specifies the name of the property.

If the **Sensitive** attribute of the **PackageParameterType** element that contains the **PackageParameterPropertyType** element has the value True, this element MUST contain a child element of type [PackageParameterEncryptedValuePropertyType](#) and MUST NOT contain a simple value.

2.4.7.3 PackageParameterEncryptedValuePropertyType

The **PackageParameterEncryptedValuePropertyType** complex type is used to specify the value of a sensitive package parameter.

The following is the XSD for the **PackageParameterEncryptedValuePropertyType** complex type.

```
<xs:complexType name="PackageParameterPropertyEncryptedValuePropertyType">
  <xs:simpleContent>
    <xs:extension base="xs:string">
      <xs:attribute name="DataType" type="xs:unsignedByte" use="required" />
      <xs:attribute name="Name" type="xs:string" use="required" />
      <xs:attribute name="Encrypted" type="xs:unsignedByte" use="required" />
    </xs:extension>
  </xs:simpleContent>
</xs:complexType>
```

The following table provides additional information about the attributes of the **PackageParameterEncryptedValuePropertyType**.

Attribute	Constraints	Description
DataType	MUST be the same as the value of the DataType attribute of the PackageParameterType element that contains the PackageParameterEncryptedValuePropertyType element. MUST be present when the Sensitive attribute of the PackageParameterType element that contains the PackageParameterEncryptedValuePropertyType element is not present or has the value False. Must not be present when the value of that attribute is True.	Specifies the data type of the property.
Name	MUST be the value DefaultValue.	Specifies the name of the property.
Encrypted	MUST be the value 1.	Specifies that the value is encrypted.

2.5 ExecutablesType

The **ExecutablesType** complex type is the container type for a collection of elements of type [AnyNonPackageExecutableType](#).

The following is the XSD of the **ExecutablesType** complex type.

```
<xs:complexType name="ExecutablesType">
  <xs:sequence>
    <xs:element name="Executable" type="DTS:AnyNonPackageExecutableType"
      minOccurs="0" maxOccurs="unbounded"/>
  </xs:sequence>
</xs:complexType>
```

The following table provides additional information about the elements, types, and constraints for the **ExecutablesType** complex type.

Element	Type definition	Description
Executable	AnyNonPackageExecutableType	Specifies an Executable element that in turn specifies an executable to execute along with the options, parameters, and settings for the executable.

2.5.1 AnyNonPackageExecutableType

The **AnyNonPackageExecutableType** complex type is the type of an [Executable](#) element that is contained within another **Executable** element. That is, it is the type definition for any **Executable** element except the **Executable** element that is the root node of the package.

The following is the XSD for the **AnyNonPackageExecutableType** complex type.

```

<xs:complexType name="AnyNonPackageExecutableType">
  <xs:sequence>
    <xs:element name="ForEachEnumerator"
      type="DTS:ForEachEnumeratorType" minOccurs="0"/>
    <xs:element name="Variables" type="DTS:VariablesType"
      minOccurs="0"/>
    <xs:element name="LoggingOptions" type="DTS:LoggingOptionsType"
      minOccurs="0"/>
    <xs:element name="PropertyExpression"
      type="DTS:PropertyExpressionElementType"
      minOccurs="0" maxOccurs="unbounded"/>
    <xs:element name="Executables" type="DTS:ExecutablesType"
      minOccurs="0"/>
    <xs:element name="PrecedenceConstraints"
      type="DTS:PrecedenceConstraintsType"
      minOccurs="0"/>
    <xs:element name="ForEachVariableMappings"
      type="DTS:ForEachVariableMappingType" minOccurs="0"/>
    <xs:element name="EventHandlers" type="DTS:EventHandlersType"
      minOccurs="0"/>
    <xs:element name="ObjectData" type="DTS:ExecutableObjectDataType"
      minOccurs="0"/>
  </xs:sequence>
  <xs:attribute name="ExecutableType" use="required"
    type="DTS:AnyNonPackageExecutableTypeExecutableTypeEnum"/>
  <xs:attribute name="ThreadHint" use="optional" type="xs:int"/>
  <xs:attributeGroup ref="DTS:AllExecutableAttributeGroup"/>
  <xs:attributeGroup ref="DTS:BaseExecutablePropertyAttributeGroup"/>
  <xs:attributeGroup ref="DTS:BasePropertyAttributeGroup"/>
  <xs:attributeGroup ref="DTS:AnyNonPackageExecutableAttributeGroup"/>
  <xs:attribute name="refId" type="xs:string" use="required"
    form="qualified"/>
</xs:complexType>

```

The following table provides additional information about the elements, types, and constraints in the **AnyNonPackageExecutableType** complex type.

Element	Constraints	Type definition	Description
ForEachEnumerator	MUST NOT be used unless the ExecutableType attribute is equal to "STOCK:FOREACHLOOP"	ForEachEnumeratorType	Specifies a collection of elements of type ForEachEnumeratorType . Each such element defines the iterations of a For...Each loop that is available to the executable.
Variables	None	VariablesType	Specifies a collection of elements of type VariableType . Each such element defines a variable that is available to the executable.
LoggingOptions	None	LoggingOptionsType	Specifies information about what kind of information is logged for this package and

Element	Constraints	Type definition	Description
			where it is recorded.
PropertyExpression	Additional constraints exist for the PropertyExpression element.	PropertyExpressionElement	Serves the same purpose as specified for the Property element except that an expression that is evaluated at run time is contained in the element's value.
Executables	None	ExecutablesType	Specifies a collection of elements of type AnyNonPackageExecutableType . Each such element defines an executable that is available to the executable.
PrecedenceConstraints	None	PrecedenceConstraintsType	Specifies a collection of elements of type PrecedenceConstraintType . Each such element defines a precedence constraint that is available to the executable.
ForEachVariableMappings	MUST NOT be used unless the ExecutableType attribute is equal to "STOCK:FOREACHLOOP"	ForEachVariableMappingsType	Specifies a collection of elements of type ForEachVariableMappingType . Each such element defines variable mappings for the iterations of a For...Each loop that are available to the executable that contains the collection.
EventHandlers	None	EventHandlersType	Specifies a collection of elements of type EventHandlerType . Each such element defines an event handler that is available to the executable.
ObjectData	Each value of the attribute ExecutableType constrains the choice that is contained in the definition of ExecutableObjectData to a specific choice. For more information, see ExecutableType Attribute Values for Different Executable Types .	ExecutableObjectData	Contains information specific to the Executable . The nature of the information varies with the value of the ExecutableType attribute. For more information, see Executable ObjectData Types .

The following table provides additional information about the attributes, types, and constraints in the **AnyNonPackageExecutableType** complex type.

Attribute	Type definition	Description
ExecutableType	Some values of the ExecutableType attribute allow further Executable elements to be contained, and other values MUST NOT contain further Executable elements. For more information, see ExecutableType Attribute Values for Different Executable Types.	ExecutableTypePackage
ThreadHint	Not all values of ExecutableType are allowed to have the ThreadHint attribute present. For more information, see ExecutableType Attribute Values for Different Executable Types.	An integer value. <19>
refId		A string value that specifies a unique refId for this object. Elsewhere within the containing executable or within the package, the value of refId can be used to refer to this object. <20>
AllExecutableAttributeGroup	AllExecutableAttributeGroup	An attribute group that specifies attributes that are common to many different types throughout the schema.
BaseExecutablePropertyAttributeGroup	BaseExecutablePropertyAttributeGroup	An attribute group that specifies attributes that are common to many different types throughout the schema.
BasePropertyAttributeGroup	BasePropertyAttributeGroup	An attribute group that specifies attributes that are common to many different types throughout the schema.
AnyNonPackageExecutableAttributeGroup	AnyNonPackageExecutableAttributeGroup	An attribute group that specifies attributes for the AnyNonPackageExecutableType type.

The following table provides additional information about the attributes and types for the **Property** element that is declared inline in the complex type declaration. The **Property** element is an extension of the [PropertyElementBaseType](#) type with the addition of the **Name** attribute, which is specified in the following table.

Attribute	Constraints	Description
Name	None	Specifies the name of the Property element. Each named property has its own use and interpretation. The explanation for the interpretation of each named property is given with the definition of the type for the Name attribute.

2.5.1.1 AnyNonPackageExecutableTypeExecutableTypeEnum

The **AnyNonPackageExecutableTypeExecutableTypeEnum** type contains the values for the **ExecutableType** attribute of the [Executable](#) elements that are allowed on any **Executable** of type [AnyNonPackageExecutableType](#).

The following is the XSD of the **AnyNonPackageExecutableTypeExecutableTypeEnum** type.

```

<xs:simpleType name="AnyNonPackageExecutableTypeExecutableTypeEnum">
  <xs:restriction base="xs:string">
    <xs:enumeration value="SSIS.Pipeline.2"/>
    <xs:enumeration
value="Microsoft.SqlServer.Dts.Tasks.ActiveXScriptTask.ActiveXScriptTask,
Microsoft.SqlServer.ActiveXScriptTask, Version=11.0.0.0, Culture=neutral,
PublicKeyToken=89845dcd8080cc91"/>
    <xs:enumeration
value="Microsoft.DataTransformationServices.Tasks.DTSProcessingTask.ASExecutedDLTask,
Microsoft.SqlServer.ASTasks, Version=11.0.0.0, Culture=neutral,
PublicKeyToken=89845dcd8080cc91"/>
    <xs:enumeration
value="Microsoft.DataTransformationServices.Tasks.DTSProcessingTask.DTSProcessingTask,
Microsoft.SqlServer.ASTasks, Version=11.0.0.0, Culture=neutral,
PublicKeyToken=89845dcd8080cc91"/>
    <xs:enumeration value="Microsoft.SqlServer.Dts.Tasks.BulkInsertTask.BulkInsertTask,
Microsoft.SqlServer.BulkInsertTask, Version=11.0.0.0, Culture=neutral,
PublicKeyToken=89845dcd8080cc91"/>
    <xs:enumeration value="Microsoft.SqlServer.Dts.Tasks.DMQueryTask.DMQueryTask,
Microsoft.SqlServer.DMQueryTask, Version=11.0.0.0, Culture=neutral,
PublicKeyToken=89845dcd8080cc91"/>
    <xs:enumeration
value="Microsoft.SqlServer.Dts.Tasks.DataProfilingTask.DataProfilingTask,
Microsoft.SqlServer.DataProfilingTask, Version=11.0.0.0, Culture=neutral,
PublicKeyToken=89845dcd8080cc91"/>
    <xs:enumeration
value="Microsoft.SqlServer.Dts.Tasks.Exec80PackageTask.Exec80PackageTask,
Microsoft.SqlServer.Exec80PackageTask, Version=11.0.0.0, Culture=neutral,
PublicKeyToken=89845dcd8080cc91"/>
    <xs:enumeration value="SSIS.ExecutePackageTask.2"/>
    <xs:enumeration value="Microsoft.SqlServer.Dts.Tasks.ExecuteProcess.ExecuteProcess,
Microsoft.SqlServer.ExecProcTask, Version=11.0.0.0, Culture=neutral,
PublicKeyToken=89845dcd8080cc91"/>
    <xs:enumeration value="Microsoft.SqlServer.Dts.Tasks.ExecuteSQLTask.ExecuteSQLTask,
Microsoft.SqlServer.SQLTask, Version=11.0.0.0, Culture=neutral,
PublicKeyToken=89845dcd8080cc91"/>
    <xs:enumeration value="Microsoft.SqlServer.Dts.Tasks.FileSystemTask.FileSystemTask,
Microsoft.SqlServer.FileSystemTask, Version=11.0.0.0, Culture=neutral,
PublicKeyToken=89845dcd8080cc91"/>
    <xs:enumeration value="Microsoft.SqlServer.Dts.Tasks.FtpTask.FtpTask,
Microsoft.SqlServer.FtpTask, Version=11.0.0.0, Culture=neutral,
PublicKeyToken=89845dcd8080cc91"/>
  </xs:restriction>
</xs:simpleType>

```



```

    <xs:enumeration value="Microsoft.SqlServer.Dts.Tasks.MessageQueueTask.MessageQueueTask,
Microsoft.SqlServer.MSMQTask, Version=11.0.0.0, Culture=neutral,
PublicKeyToken=89845dcd8080cc91"/>
    <xs:enumeration value="Microsoft.SqlServer.Dts.Tasks.ScriptTask.ScriptTask,
Microsoft.SqlServer.ScriptTask, Version=11.0.0.0, Culture=neutral,
PublicKeyToken=89845dcd8080cc91"/>
    <xs:enumeration value="Microsoft.SqlServer.Dts.Tasks.SendMailTask.SendMailTask,
Microsoft.SqlServer.SendMailTask, Version=11.0.0.0, Culture=neutral,
PublicKeyToken=89845dcd8080cc91"/>
    <xs:enumeration
value="Microsoft.SqlServer.Dts.Tasks.TransferDatabaseTask.TransferDatabaseTask,
Microsoft.SqlServer.TransferDatabasesTask, Version=11.0.0.0, Culture=neutral,
PublicKeyToken=89845dcd8080cc91"/>
    <xs:enumeration
value="Microsoft.SqlServer.Dts.Tasks.TransferErrorMessagesTask.TransferErrorMessagesTask,
Microsoft.SqlServer.TransferErrorMessagesTask, Version=11.0.0.0, Culture=neutral,
PublicKeyToken=89845dcd8080cc91"/>
    <xs:enumeration value="Microsoft.SqlServer.Dts.Tasks.TransferJobsTask.TransferJobsTask,
Microsoft.SqlServer.TransferJobsTask, Version=11.0.0.0, Culture=neutral,
PublicKeyToken=89845dcd8080cc91"/>
    <xs:enumeration
value="Microsoft.SqlServer.Dts.Tasks.TransferLoginsTask.TransferLoginsTask,
Microsoft.SqlServer.TransferLoginsTask, Version=11.0.0.0, Culture=neutral,
PublicKeyToken=89845dcd8080cc91"/>
    <xs:enumeration
value="Microsoft.SqlServer.Dts.Tasks.TransferStoredProceduresTask.TransferStoredProceduresTask,
Microsoft.SqlServer.TransferStoredProceduresTask, Version=11.0.0.0, Culture=neutral,
PublicKeyToken=89845dcd8080cc91"/>
    <xs:enumeration
value="Microsoft.SqlServer.Dts.Tasks.TransferSqlServerObjectsTask.TransferSqlServerObjectsTask,
Microsoft.SqlServer.TransferSqlServerObjectsTask, Version=11.0.0.0, Culture=neutral,
PublicKeyToken=89845dcd8080cc91"/>
    <xs:enumeration value="Microsoft.SqlServer.Dts.Tasks.WebServiceTask.WebServiceTask,
Microsoft.SqlServer.WebServiceTask, Version=11.0.0.0, Culture=neutral,
PublicKeyToken=89845dcd8080cc91"/>
    <xs:enumeration
value="Microsoft.SqlServer.Dts.Tasks.WmiDataReaderTask.WmiDataReaderTask,
Microsoft.SqlServer.WMIDRTask, Version=11.0.0.0, Culture=neutral,
PublicKeyToken=89845dcd8080cc91"/>
    <xs:enumeration
value="Microsoft.SqlServer.Dts.Tasks.WmiEventWatcherTask.WmiEventWatcherTask,
Microsoft.SqlServer.WMIEventTask, Version=11.0.0.0, Culture=neutral,
PublicKeyToken=89845dcd8080cc91"/>
    <xs:enumeration value="Microsoft.SqlServer.Dts.Tasks.XMLTask.XMLTask,
Microsoft.SqlServer.XMLTask, Version=11.0.0.0, Culture=neutral,
PublicKeyToken=89845dcd8080cc91"/>
    <xs:enumeration
value="Microsoft.SqlServer.Management.DatabaseMaintenance.DbMaintenanceBackupTask,
Microsoft.SqlServer.MaintenancePlanTasks, Version=11.0.0.0, Culture=neutral,
PublicKeyToken=89845dcd8080cc91"/>
    <xs:enumeration
value="Microsoft.SqlServer.Management.DatabaseMaintenance.DbMaintenanceCheckIntegrityTask,
Microsoft.SqlServer.MaintenancePlanTasks, Version=11.0.0.0, Culture=neutral,
PublicKeyToken=89845dcd8080cc91"/>
    <xs:enumeration
value="Microsoft.SqlServer.Management.DatabaseMaintenance.DbMaintenanceExecuteAgentJobTask,
Microsoft.SqlServer.MaintenancePlanTasks, Version=11.0.0.0, Culture=neutral,
PublicKeyToken=89845dcd8080cc91"/>
    <xs:enumeration
value="Microsoft.SqlServer.Management.DatabaseMaintenance.DbMaintenanceHistoryCleanupTask,
Microsoft.SqlServer.MaintenancePlanTasks, Version=11.0.0.0, Culture=neutral,
PublicKeyToken=89845dcd8080cc91"/>

```

```

    <xs:enumeration
value="Microsoft.SqlServer.Management.DatabaseMaintenance.DbMaintenanceFileCleanupTask,
Microsoft.SqlServer.MaintenancePlanTasks, Version=11.0.0.0, Culture=neutral,
PublicKeyToken=89845dcd8080cc91"/>
    <xs:enumeration
value="Microsoft.SqlServer.Management.DatabaseMaintenance.DbMaintenanceNotifyOperatorTask,
Microsoft.SqlServer.MaintenancePlanTasks, Version=11.0.0.0, Culture=neutral,
PublicKeyToken=89845dcd8080cc91"/>
    <xs:enumeration
value="Microsoft.SqlServer.Management.DatabaseMaintenance.DbMaintenanceReindexTask,
Microsoft.SqlServer.MaintenancePlanTasks, Version=11.0.0.0, Culture=neutral,
PublicKeyToken=89845dcd8080cc91"/>
    <xs:enumeration
value="Microsoft.SqlServer.Management.DatabaseMaintenance.DbMaintenanceDefragmentIndexTask,
Microsoft.SqlServer.MaintenancePlanTasks, Version=11.0.0.0, Culture=neutral,
PublicKeyToken=89845dcd8080cc91"/>
    <xs:enumeration
value="Microsoft.SqlServer.Management.DatabaseMaintenance.DbMaintenanceShrinkTask,
Microsoft.SqlServer.MaintenancePlanTasks, Version=11.0.0.0, Culture=neutral,
PublicKeyToken=89845dcd8080cc91"/>
    <xs:enumeration
value="Microsoft.SqlServer.Management.DatabaseMaintenance.DbMaintenanceUpdateStatisticsTask,
Microsoft.SqlServer.MaintenancePlanTasks, Version=11.0.0.0, Culture=neutral,
PublicKeyToken=89845dcd8080cc91"/>
    <xs:enumeration
value="Microsoft.SqlServer.Management.DatabaseMaintenance.DbMaintenanceTSQLExecuteTask,
Microsoft.SqlServer.MaintenancePlanTasks, Version=11.0.0.0, Culture=neutral,
PublicKeyToken=89845dcd8080cc91"/>
    <xs:enumeration value="STOCK:FORLOOP"/>
    <xs:enumeration value="STOCK:FOREACHLOOP"/>
    <xs:enumeration value="STOCK:SEQUENCE"/>
    <xs:enumeration value="STOCK:ActiveXScriptTask"/>
    <xs:enumeration value="STOCK:BulkInsertTask"/>
    <xs:enumeration value="STOCK:ExecuteProcessTask"/>
    <xs:enumeration value="STOCK:ExecutePackageTask"/>
    <xs:enumeration value="STOCK:Exec80PackageTask"/>
    <xs:enumeration value="STOCK:FileSystemTask"/>
    <xs:enumeration value="STOCK:FTPTask"/>
    <xs:enumeration value="STOCK:MSMQTask"/>
    <xs:enumeration value="STOCK:PipelineTask"/>
    <xs:enumeration value="STOCK:ScriptTask"/>
    <xs:enumeration value="STOCK:SendMailTask"/>
    <xs:enumeration value="STOCK:SQLTask"/>
    <xs:enumeration value="STOCK:TransferStoredProceduresTask"/>
    <xs:enumeration value="STOCK:TransferLoginsTask"/>
    <xs:enumeration value="STOCK:TransferErrorMessagesTask"/>
    <xs:enumeration value="STOCK:TransferJobsTask"/>
    <xs:enumeration value="STOCK:TransferObjectsTask"/>
    <xs:enumeration value="STOCK:TransferDatabaseTask"/>
    <xs:enumeration value="STOCK:WebServiceTask"/>
    <xs:enumeration value="STOCK:WmiDataReaderTask"/>
    <xs:enumeration value="STOCK:WmiEventWatcherTask"/>
    <xs:enumeration value="STOCK:XMLTask"/>
  </xs:restriction>
</xs:simpleType>

```

The following table specifies the enumeration values for the **AnyNonPackageExecutableTypeExecutableTypeEnum** type. Note that there are multiple rows in the table for the same task executable in some cases. This is because some of the enumeration values are synonyms for each other.

Enumeration value	Description
SSIS.Pipeline.2	Pipeline executable.
Microsoft.SqlServer.Dts.Tasks.ActiveXScriptTask.ActiveXScriptTask, Microsoft.SqlServer.ActiveXScriptTask, Version=11.0.0.0, Culture=neutral, PublicKeyToken=89845dcd8080cc91	ActiveX Script Task executable.
Microsoft.DataTransformationServices.Tasks.DTSProcessingTask.ASExecuteDDLTask, Microsoft.SqlServer.ASTasks, Version=11.0.0.0, Culture=neutral, PublicKeyToken=89845dcd8080cc91	Analysis Services (AS) Execute Data Definition Language (DDL) Task executable.
Microsoft.DataTransformationServices.Tasks.DTSProcessingTask.DTSProcessingTask, Microsoft.SqlServer.ASTasks, Version=11.0.0.0, Culture=neutral, PublicKeyToken=89845dcd8080cc91	AS Processing Task executable.
Microsoft.SqlServer.Dts.Tasks.BulkInsertTask.BulkInsertTask, Microsoft.SqlServer.BulkInsertTask, Version=11.0.0.0, Culture=neutral, PublicKeyToken=89845dcd8080cc91	Bulk Insert Task executable.
Microsoft.SqlServer.Dts.Tasks.DMQueryTask.DMQueryTask, Microsoft.SqlServer.DMQueryTask, Version=11.0.0.0, Culture=neutral, PublicKeyToken=89845dcd8080cc91	Data Mining Query Task executable.
Microsoft.SqlServer.Dts.Tasks.DataProfilingTask.DataProfilingTask, Microsoft.SqlServer.DataProfilingTask, Version=11.0.0.0, Culture=neutral, PublicKeyToken=89845dcd8080cc91	Data Profiling Task executable.
Microsoft.SqlServer.Dts.Tasks.Exec80PackageTask.Exec80PackageTask, Microsoft.SqlServer.Exec80PackageTask, Version=11.0.0.0, Culture=neutral, PublicKeyToken=89845dcd8080cc91	Execute DTS 2000 Package Task executable.
SSIS.ExecutePackageTask.2	Execute Package Task.
Microsoft.SqlServer.Dts.Tasks.ExecuteProcess.ExecuteProcess, Microsoft.SqlServer.ExecProcTask, Version=11.0.0.0, Culture=neutral, PublicKeyToken=89845dcd8080cc91	Execute Process Task executable.
Microsoft.SqlServer.Dts.Tasks.ExecuteSQLTask.ExecuteSQLTask, Microsoft.SqlServer.SQLTask, Version=11.0.0.0, Culture=neutral, PublicKeyToken=89845dcd8080cc91	Execute SQL Task executable.
Microsoft.SqlServer.Dts.Tasks.FileSystemTask.FileSystemTask, Microsoft.SqlServer.FileSystemTask, Version=11.0.0.0, Culture=neutral, PublicKeyToken=89845dcd8080cc91	File System Task executable.

Enumeration value	Description
Microsoft.SqlServer.Dts.Tasks.FtpTask.FtpTask, Microsoft.SqlServer.FtpTask, Version=11.0.0.0, Culture=neutral, PublicKeyToken=89845dcd8080cc91	FTP Task executable.
Microsoft.SqlServer.Dts.Tasks.MessageQueueTask.MessageQueueTask, Microsoft.SqlServer.MSMQTask, Version=11.0.0.0, Culture=neutral, PublicKeyToken=89845dcd8080cc91	Message Queue Task executable.
Microsoft.SqlServer.Dts.Tasks.ScriptTask.ScriptTask, Microsoft.SqlServer.ScriptTask, Version=11.0.0.0, Culture=neutral, PublicKeyToken=89845dcd8080cc91	Script Task executable.
Microsoft.SqlServer.Dts.Tasks.SendMailTask.SendMailTask, Microsoft.SqlServer.SendMailTask, Version=11.0.0.0, Culture=neutral, PublicKeyToken=89845dcd8080cc91	Send Mail Task executable.
Microsoft.SqlServer.Dts.Tasks.TransferDatabaseTask.TransferDatabaseTask, Microsoft.SqlServer.TransferDatabasesTask, Version=11.0.0.0, Culture=neutral, PublicKeyToken=89845dcd8080cc91	Transfer Database Task executable.
Microsoft.SqlServer.Dts.Tasks.TransferErrorMessagesTask.TransferErrorMessagesTask, Microsoft.SqlServer.TransferErrorMessagesTask, Version=11.0.0.0, Culture=neutral, PublicKeyToken=89845dcd8080cc91	Transfer Error Messages Task executable.
Microsoft.SqlServer.Dts.Tasks.TransferJobsTask.TransferJobsTask, Microsoft.SqlServer.TransferJobsTask, Version=11.0.0.0, Culture=neutral, PublicKeyToken=89845dcd8080cc91	Transfer Jobs Task executable.
Microsoft.SqlServer.Dts.Tasks.TransferLoginsTask.TransferLoginsTask, Microsoft.SqlServer.TransferLoginsTask, Version=11.0.0.0, Culture=neutral, PublicKeyToken=89845dcd8080cc91	Transfer Logins Task executable.
Microsoft.SqlServer.Dts.Tasks.TransferStoredProceduresTask.TransferStoredProceduresTask, Microsoft.SqlServer.TransferStoredProceduresTask, Version=11.0.0.0, Culture=neutral, PublicKeyToken=89845dcd8080cc91	Transfer Stored Procedures Task executable.
Microsoft.SqlServer.Dts.Tasks.TransferSqlServerObjectsTask.TransferSqlServerObjectsTask, Microsoft.SqlServer.TransferSqlServerObjectsTask, Version=11.0.0.0, Culture=neutral, PublicKeyToken=89845dcd8080cc91	Transfer SQL Server Objects Task executable.
Microsoft.SqlServer.Dts.Tasks.WebServiceTask.WebServiceTask, Microsoft.SqlServer.WebServiceTask, Version=11.0.0.0, Culture=neutral, PublicKeyToken=89845dcd8080cc91	Web Service Task executable.
Microsoft.SqlServer.Dts.Tasks.WmiDataReaderTask.WmiDataReaderTask, Microsoft.SqlServer.WMIDRTask, Version=11.0.0.0, Culture=neutral, PublicKeyToken=89845dcd8080cc91	WMI Data Reader Task executable.
Microsoft.SqlServer.Dts.Tasks.WmiEventWatcherTask.WmiEventWatcherTask, Microsoft.SqlServer.WMIIEWTask, Version=11.0.0.0, Culture=neutral, PublicKeyToken=89845dcd8080cc91	WMI Event Watcher Task executable.

Enumeration value	Description
Microsoft.SqlServer.Dts.Tasks.XMLTask.XMLTask, Microsoft.SqlServer.XMLTask, Version=11.0.0.0, Culture=neutral, PublicKeyToken=89845dcd8080cc91	XML Task executable.
Microsoft.SqlServer.Management.DatabaseMaintenance.DbMaintenanceBackupTask, Microsoft.SqlServer.MaintenancePlanTasks, Version=11.0.0.0, Culture=neutral, PublicKeyToken=89845dcd8080cc91	Backup Task.
Microsoft.SqlServer.Management.DatabaseMaintenance.DbMaintenanceCheckIntegrityTask, Microsoft.SqlServer.MaintenancePlanTasks, Version=11.0.0.0, Culture=neutral, PublicKeyToken=89845dcd8080cc91	Check Integrity Task.
Microsoft.SqlServer.Management.DatabaseMaintenance.DbMaintenanceExecuteAgentJobTask, Microsoft.SqlServer.MaintenancePlanTasks, Version=11.0.0.0, Culture=neutral, PublicKeyToken=89845dcd8080cc91	Execute SQL Agent Job Task.
Microsoft.SqlServer.Management.DatabaseMaintenance.DbMaintenanceHistoryCleanupTask, Microsoft.SqlServer.MaintenancePlanTasks, Version=11.0.0.0, Culture=neutral, PublicKeyToken=89845dcd8080cc91	History Cleanup Task.
Microsoft.SqlServer.Management.DatabaseMaintenance.DbMaintenanceFileCleanupTask, Microsoft.SqlServer.MaintenancePlanTasks, Version=11.0.0.0, Culture=neutral, PublicKeyToken=89845dcd8080cc91	Maintenance File Cleanup Task.
Microsoft.SqlServer.Management.DatabaseMaintenance.DbMaintenanceNotifyOperatorTask, Microsoft.SqlServer.MaintenancePlanTasks, Version=11.0.0.0, Culture=neutral, PublicKeyToken=89845dcd8080cc91	Notify Operator Task.
Microsoft.SqlServer.Management.DatabaseMaintenance.DbMaintenanceReindexTask, Microsoft.SqlServer.MaintenancePlanTasks, Version=11.0.0.0, Culture=neutral, PublicKeyToken=89845dcd8080cc91	Rebuild Index Task.
Microsoft.SqlServer.Management.DatabaseMaintenance.DbMaintenanceDefragmentIndexTask, Microsoft.SqlServer.MaintenancePlanTasks, Version=11.0.0.0, Culture=neutral, PublicKeyToken=89845dcd8080cc91	Reorganize Index Task.
Microsoft.SqlServer.Management.DatabaseMaintenance.DbMaintenanceShrinkTask, Microsoft.SqlServer.MaintenancePlanTasks, Version=11.0.0.0, Culture=neutral, PublicKeyToken=89845dcd8080cc91	Shrink Database Task.
Microsoft.SqlServer.Management.DatabaseMaintenance.DbMaintenanceUpdateStatisticsTask, Microsoft.SqlServer.MaintenancePlanTasks, Version=11.0.0.0, Culture=neutral, PublicKeyToken=89845dcd8080cc91	Update Statistics Task.
Microsoft.SqlServer.Management.DatabaseMaintenance.DbMaintenanceTSQLExecuteTask, Microsoft.SqlServer.MaintenancePlanTasks, Version=11.0.0.0, Culture=neutral, PublicKeyToken=89845dcd8080cc91	Execute TSQL Task.
STOCK:FORLOOP	For Loop container executable.
STOCK:FOREACHLOOP	For Each Loop container executable.
STOCK:SEQUENCE	Sequence container

Enumeration value	Description
	executable.
STOCK:ActiveXScriptTask	ActiveX Script Task executable.
STOCK:BulkInsertTask	Bulk Insert Task executable.
STOCK:ExecuteProcessTask	Execute Process Task executable.
STOCK:Exec80PackageTask	Execute DTS 2000 Package Task executable.
STOCK:FileSystemTask	File system task executable.
STOCK:FTPTask	FTP Task executable.
STOCK:MSMQTask	Message Queue Task executable.
STOCK:PipelineTask	Pipeline executable.
STOCK:ScriptTask	Script Task executable.
STOCK:SendMailTask	Send Mail Task executable.
STOCK:SQLTask	Execute SQL Task executable.
STOCK:TransferStoredProceduresTask	Transfer Stored Procedures Task executable.
STOCK:TransferJobsTask	Transfer Jobs Task executable.
STOCK:TransferObjectsTask	Transfer SQL Server Objects Task executable.

Enumeration value	Description
STOCK:TransferDatabaseTask	Transfer Database Task executable.
STOCK:WebServiceTask	Web Service Task executable.
STOCK:WmiDataReaderTask	WMI Data Reader task executable.
STOCK:WmiEventWatcherTask	WMI Event Watcher task executable.
STOCK:XMLTask	XML Task executable.

2.5.1.1.1 ForEachEnumeratorType

The **ForEachEnumeratorType** complex type MUST NOT be used for an executable unless its **ExecutableType** attribute is equal to "STOCK:FOREACHLOOP". The **ForEachEnumeratorType** complex type contains information about the entity to be looped over and the logic of the looping.

The following is the XSD for the **ForEachEnumeratorType** complex type.

```
<xs:complexType name="ForEachEnumeratorType">
  <xs:sequence>
    <xs:element name="PropertyExpression"
      type="DTS:PropertyExpressionElementType"
      minOccurs="0" maxOccurs="unbounded"/>
    <xs:element name="ObjectData"
      type="DTS:ForEachEnumeratorObjectDataType"/>
  </xs:sequence>
  <xs:attributeGroup ref="DTS:BasePropertyAttributeGroup"/>
</xs:complexType>
```

The following table provides additional information about the elements, types, and constraints in the **ForEachEnumeratorType** complex type.

Element	Additional constraints	Type definition	Description
PropertyExpression	Additional constraints exist for the PropertyExpression element. These constraints MUST be followed.	PropertyExpressionElementType	Serves the same purpose as described for the Property element, except that an expression that is evaluated at runtime is contained in the element's value that

Element	Additional constraints	Type definition	Description
			is stored in the Microsoft® SQL Server® Integration Services (SSIS) file format.
ObjectData	None	ForEachEnumeratorObjectDataTy e	Contains information that is specific to the ForEachEnumerator . For more information, see Executable ObjectData Types .

The following table provides additional information about the attributes, attribute groups, and types for the **ForEachEnumeratorType** complex type.

Attribute	Description
BasePropertyAttributeGroup	An attribute group that specifies attributes that are common to many different types throughout the schema.

The **ForEachEnumeratorType** complex type has no additional attributes or attribute groups beyond those of the **BasePropertyAttributeGroup** attribute group. Therefore, no further attribute groups are described in any of this section's subsections.

2.5.1.1.1.1 ForEachEnumeratorObjectDataType

The **ForEachEnumeratorObjectDataType** complex type contains information that is specific to each type of **For...Each** loop.

The following is the XSD of the **ForEachEnumeratorObjectDataType** complex type.

```
<xs:complexType name="ForEachEnumeratorObjectDataType">
  <xs:choice>
    <xs:element name="FEIEItems" type="DTS:FEIEItemsType"
      form="unqualified"/>
    <xs:element name="ForEachFileEnumeratorProperties"
      type="DTS:ForEachFileEnumeratorPropertiesType"
      form="unqualified"/>
    <xs:element name="FEEADO" type="DTS:FEEADOType"
      form="unqualified"/>
    <xs:element name="FEESchemaRowset" type="DTS:FEESchemaRowsetType"
      form="unqualified"/>
    <xs:element name="FEEFVE" type="DTS:FEEFVEType" form="unqualified"/>
    <xs:element name="FEENODELIST" type="DTS:FEENODELISTType"
      form="unqualified"/>
    <xs:element name="FEESMO" type="DTS:FEESMOType" form="unqualified"/>
  </xs:choice>
</xs:complexType>
```

The following table provides additional information about the elements, types, and constraints in the **ForEachEnumeratorObjectDataType** complex type.

Element	Additional constraints	Type definition	Description
FEIEItems	None	FEIEItemsType	Specifies a collection of items over which enumeration is performed.
ForEachFileEnumeratorProperties	None	ForEachFileEnumeratorPropertiesType	Specifies properties for enumeration over a set of files.
FEEADO	None	FEEADOType	Specifies properties and parameters for enumeration over the rows of an ADO recordset or over an ADO.NET dataset.
FEESchemaRowset	None	FEESchemaRowsetType	Specifies properties and parameters for enumeration over the tables of a database schema.
FEFVE	None	FEFVEType	Specifies properties and parameters for enumeration over the content of a variable in the package.
FEENODELIST	None	FEENODELISTType	Specifies

Element	Additional constraints	Type definition	Description
			properties and parameters for enumeration over the nodes in an XML document.
FEESMO	None	FEESMOType	Specifies properties and parameters for enumeration over tables in a database schema using an SMO Server connection.

2.5.1.1.1.1.1 FEIEItemsType

The **FEIEItemsType** complex type specifies a collection of items over which enumeration is performed.

The following is the XSD of the **FEIEItemsType** complex type.

```
<xs:complexType name="FEIEItemsType">
  <xs:sequence>
    <xs:element name="FEIEItem" type="DTS:FEIEItemType"
      maxOccurs="unbounded" form="unqualified"/>
  </xs:sequence>
</xs:complexType>
```

The following table provides additional information about the elements, types, and constraints in the **FEIEItemsType** complex type.

Element	Additional constraints	Type definition	Description
FEIEItem	None	FEIEItemType	Specifies an individual item within the collection of items over which enumeration is being performed.

2.5.1.1.1.1.1.1 FEIEItemType

The **FEIEItemType** complex type specifies an individual item within a collection of items over which enumeration is performed.

The following is the XSD of the **FEIEItem** complex type.

```
<xs:complexType name="FEIEItem">
  <xs:sequence>
    <xs:element name="FEIEItemValue" maxOccurs="unbounded"
      form="unqualified" type="DTS:FEIEItemValueType"/>
  </xs:sequence>
</xs:complexType>
```

The following table provides additional information about the elements, types, and constraints in the **FEIEItem** complex type.

Element	Additional constraints	Type definition	Description
FEIEItemValue	None	FEIEItemValue Type	Contains the type of and the value for an individual item in the enumeration collection.

2.5.1.1.1.1.1.1 FEIEItemValue Type

The **FEIEItemValueType** complex type specifies the value for an individual FEIEItem item.

The following is the XSD of the **FEIEItemValueType** complex type.

```
<xs:complexType name="FEIEItemValueType">
  <xs:sequence/>
  <xs:attribute name="Type" type="DTS:DtsDataTypeEnum"
    use="required" form="unqualified"/>
  <xs:attribute name="Value" type="xs:string"
    use="required" form="unqualified"/>
</xs:complexType>
```

The following table provides additional information about the attributes of the **FEIEItemValueType** complex type.

Attribute	Description
Type	The type of the current instance of the FEIEItemValue element.
Value	The value of the current instance of the FEIEItemValue element. The value of the Value item is interpreted as being of the type that is specified in the Type attribute.

2.5.1.1.1.1.2 ForEachFileEnumeratorPropertiesType

The **ForEachFileEnumeratorPropertiesType** complex type contains the information for enumeration over a set of files.

The following is the XSD of the **ForEachEnumeratorPropertiesType** complex type.

```
<xs:complexType name="ForEachFileEnumeratorPropertiesType">
  <xs:sequence>
```

```

<xs:element name="FEFEProperty" maxOccurs="unbounded" form="unqualified">
  <xs:complexType>
    <xs:sequence/>
    <xs:attribute name="Folder" form="unqualified"/>
    <xs:attribute name="FileSpec" form="unqualified"/>
    <xs:attribute name="FileNameRetrievalType" form="unqualified">
      <xs:simpleType>
        <xs:restriction base="xs:int">
          <xs:minInclusive value="0"/>
          <xs:maxInclusive value="2"/>
        </xs:restriction>
      </xs:simpleType>
    </xs:attribute>
    <xs:attribute name="Recurse" form="unqualified">
      <xs:simpleType>
        <xs:restriction base="xs:int">
          <xs:minInclusive value="-1"/>
          <xs:maxInclusive value="0"/>
        </xs:restriction>
      </xs:simpleType>
    </xs:attribute>
  </xs:complexType>
</xs:element>
</xs:sequence>
</xs:complexType>

```

The following table provides additional information about the attributes for the **FEFEProperty** element of the **ForEachFileEnumeratorPropertiesType** complex type.

Attribute	Additional constraints	Description
Folder	None	Specifies a string that contains a folder name over which to enumerate files.
FileSpec	None	Specifies a string that contains a file specification.
FileNameRetrievalType	None	Specifies the nature of the file name retrieval specification, according to the following integer values: 0 specifies a fully qualified file name. 1 specifies a file name and a file name extension. 2 specifies only a file name.
Recurse	None	Specifies whether to traverse all subfolders to search for files that match the file specification according to the following integer values: -1 specifies TRUE; do traverse subfolders. 0 specifies FALSE; do not traverse subfolders.

2.5.1.1.1.1.3 FEEADOType

The **FEEADOType** complex type specifies enumeration over the rows of an ADO recordset or over an ADO.NET dataset.

The following is the XSD of the **FEEADOType** complex type.

```

<xs:complexType name="FEEADOType">
  <xs:sequence/>
  <xs:attribute name="EnumType" use="required" form="unqualified"
    type="DTS:FEEADOEnumType"/>
  <xs:attribute name="VarName" type="xs:string"
    use="required" form="unqualified"/>
</xs:complexType>

```

The following table provides additional information about the attributes of the **FEEADOType** complex type.

Attribute	Additional constraints	Description
EnumType	None	Specifies the type of enumeration to perform over the tables of a database or over the tables of an ADO.NET dataset.
VarName	None	Specifies a string that contains the name of the variable that contains the results over which to perform the enumeration.

2.5.1.1.1.3.1 FEEADOEnumType

The **FEEADOEnumType** type specifies the enumeration values for the **FEEADO** element.

The following is the XSD of the **FEEADOEnumType** type.

```

<xs:simpleType name="FEEADOEnumType">
  <xs:restriction base="xs:string">
    <xs:enumeration value="EnumerateRowsInFirstTable"/>
    <xs:enumeration value="EnumerateAllRows"/>
    <xs:enumeration value="EnumerateTables"/>
  </xs:restriction>
</xs:simpleType>

```

The following table specifies the enumeration values for the **NodelistEnumerationTypeEnum** type.

Enumeration value	Description
EnumerateRowsInFirstTable	Enumerate over the row values in only the first table.
EnumerateAllRows	Enumerate over all rows in all tables.
EnumerateTables	Enumerate over each table.

2.5.1.1.1.4 FEESchemaRowsetType

The **FEESchemaRowsetType** complex type specifies enumeration over tables in a database schema.

The following is the XSD of the **FEESchemaRowsetType** complex type.

```

<xs:complexType name="FEESchemaRowsetType">
  <xs:sequence>
    <xs:element name="Restriction" maxOccurs="unbounded"
      form="unqualified" type="DTS:RestrictionElementType"/>
  </xs:sequence>
  <xs:attribute name="Connection" type="xs:string"
    use="required" form="unqualified"/>
  <xs:attribute name="Schema" type="DTS:uuid"
    use="required" form="unqualified"/>
</xs:complexType>

```

The following table provides additional information about the elements, types, and constraints in the **FEESchemaRowsetType** complex type.

Element	Additional constraints	Type definition	Description
Restriction	None	RestrictionElementType	Specifies a restriction on the schema rowset. The enumeration occurs with the result after application of the restriction.

The following table provides additional information about the attributes of the **FEESchemaRowsetType** type.

Attribute	Additional constraints	Description
Connection	None	Specifies a string that contains the connection to schema for enumeration.
Schema	None	Specifies the GUID of the schema that is desired for the enumeration.

2.5.1.1.1.4.1 RestrictionElementType

The **RestrictionElementType** complex type specifies a restriction that is applied against a schema.

The following is the XSD of the **RestrictionElementType** complex type.

```

<xs:complexType name="RestrictionElementType">
  <xs:sequence/>
  <xs:attribute name="Index" type="xs:int" use="required"
    form="unqualified"/>
  <xs:attribute name="Value" type="xs:string" use="required"
    form="unqualified"/>
</xs:complexType>

```

The **RestrictionElementType** complex type contains no elements.

The following table provides additional information about the attributes of the **RestrictionElementType** complex type.

Attribute	Additional constraints	Description
Index	None	An integer that represents the index number of this restriction.
Value	None	A string that is the value for this restriction.

2.5.1.1.1.1.5 FEEFVEType

The **FEEFVEType** complex type specifies enumeration over values that are contained in a variable.

The following is the XSD for the **FEEFVEType** complex type.

```
<xs:complexType name="FEEFVEType">
  <xs:sequence/>
  <xs:attribute name="VariableName" type="xs:string"
    form="unqualified" use="required"/>
</xs:complexType>
```

The **FEEFVEType** complex type contains no elements.

The following table provides additional information about the attributes for the **FEEFVEType** complex type.

Attribute	Description
VariableName	A string that specifies the name of the variable that contains the information over which the For...Each enumerator is performed.

2.5.1.1.1.1.6 FEENODELISTType

The **FEENODELISTType** complex type specifies enumeration over a list of XML nodes that is obtained by applying an XPATH expression to an XML file.

The following is the XSD for the **FEENODELISTType** complex type.

```
<xs:complexType name="FEENODELISTType">
  <xs:sequence/>
  <xs:attribute name="EnumerationType"
    type="DTS:NodelistEnumerationTypeEnum"
    form="unqualified" use="required"/>
  <xs:attribute name="OuterXPathSourceType" form="unqualified"
    use="required" type="DTS:SourceTypeEnum"/>
  <xs:attribute name="OuterXPathString" type="xs:string"
    form="unqualified" use="required"/>
  <xs:attribute name="InnerElementType"
    type="DTS:NodelistInnerElementEnumerationTypeEnum"
    use="required" form="unqualified"/>
  <xs:attribute name="InnerXPathSourceType" form="unqualified"
    use="required" type="DTS:SourceTypeEnum"/>
  <xs:attribute name="InnerXPathString" type="xs:string"
    form="unqualified" use="required"/>
  <xs:attribute name="SourceType" form="unqualified"
    use="required" type="DTS:SourceTypeEnum"/>
```

```

    <xs:attribute name="SourceDocument" type="xs:string"
                use="required" form="unqualified"/>
</xs:complexType>

```

The **FEENODELISTType** complex type contains no elements.

The following table provides additional information about the attributes for the **FEENODELISTType** complex type.

Attribute	Description
EnumerationType	Specifies the type of enumeration.
OuterXPathSourceType	Specifies the source type for the XPath [XPath] string.
OuterXPathString	Specifies a string that contains an XPath expression that is applied to an XML file to obtain the nodes over which enumeration occurs.
InnerElementType	Specifies the type of enumeration for the inner element. The InnerElementType applies only if the EnumeartionType attribute is set to "ElementCollection".
InnerXPathSourceType	Specifies the source type for the inner XPath string.
SourceType	Specifies the source of the XML.
SourceDocument	Specifies a string that contains the name of the source document for the XML.

2.5.1.1.1.1.6.1 NodelistEnumerationTypeEnum

The **NodelistEnumerationTypeEnum** type contains enumeration values that are used to set the type the enumeration over nodes.

The following is the XSD for the **NodelistEnumerationTypeEnum** type.

```

<xs:simpleType name="NodelistEnumerationTypeEnum">
  <xs:restriction base="xs:string">
    <xs:enumeration value="Navigator"/>
    <xs:enumeration value="Node"/>
    <xs:enumeration value="NodeText"/>
    <xs:enumeration value="ElementCollection"/>
  </xs:restriction>
</xs:simpleType>

```

The following table specifies the enumeration values for the **NodelistEnumerationTypeEnum** type.

Enumeration value	Description
Navigator	Enumerate using an XPathNavigator .
Node	Enumerate nodes that are returned by an XPath operation.
NodeText	Enumerate text nodes that are returned by an XPath operation.

Enumeration value	Description
ElementCollection	Enumerate element nodes that are returned by an XPath operation.

2.5.1.1.1.1.6.2 NodelistInnerElementEnumerationTypeEnum

The **NodelistInnerElementEnumerationTypeEnum** type contains enumeration values that are used to set the type the enumeration over inner element nodes.

The following is the XSD for the **NodelistInnerElementEnumerationTypeEnum** type.

```
<xs:simpleType name="NodelistInnerElementEnumerationTypeEnum">
  <xs:restriction base="xs:string">
    <xs:enumeration value="Navigator"/>
    <xs:enumeration value="Node"/>
    <xs:enumeration value="NodeText"/>
  </xs:restriction>
</xs:simpleType>
```

The following table specifies the enumeration values for the **NodelistInnerElementEnumerationTypeEnum** type.

Enumeration value	Description
Navigator	Enumerate using an XPathNavigator.
Node	Enumerate nodes that are returned by an XPath operation.
NodeText	Enumerate text nodes that are returned by an XPath operation.

2.5.1.1.1.1.7 FEESMOType

The **FEESMOType** complex type derives enumeration over an SMO object.

The following is the XSD for the **FEESMOType** complex type.

```
<xs:complexType name="FEESMOType">
  <xs:sequence/>
  <xs:attribute name="EnumURN" type="xs:string"
    form="unqualified" use="required"/>
</xs:complexType>
```

The **FEESMOType** complex type contains no elements.

The following table provides additional information about the attributes for the **FEESMOType** complex type.

Attribute	Description
EnumURN	A string that specifies the content of the SMO object to enumerate.

2.5.2 ForEachVariableMappingsType

The **ForEachVariableMappingsType** complex type is the container type for a collection of elements of type [ForEachVariableMappingType](#).

The following is the XSD of the **ForEachVariableMappingsType** complex type.

```
<xs:complexType name="ForEachVariableMappingsType">
  <xs:sequence>
    <xs:element name="ForEachVariableMapping"
      type="DTS:ForEachVariableMappingType"
      minOccurs="0" maxOccurs="unbounded" form="qualified"/>
  </xs:sequence>
</xs:complexType>
```

The following table provides additional information about the elements, types, and constraints for the **ForEachVariableMappingsType** complex type.

Element	Type definition	Description
ForEachVariableMapping	ForEachVariableMappingType	Specifies an element of type ForEachVariableMappingType that contains information about the variable mapping for a For...Each loop and that applies to the element that contains the collection.

2.5.2.1 ForEachVariableMappingType

The **ForEachVariableMappingType** complex type MUST NOT be used for an executable unless its **ExecutableType** attribute value is equal to "STOCK:FOREACHLOOP". It contains information about the variable mapping for a **For...Each** enumeration.

The following is the XSD for the **ForEachVariableMappingType** complex type.

```
<xs:complexType name="ForEachVariableMappingType" >
  <xs:sequence>
    <xs:element name="PropertyExpression"
      type="DTS:PropertyExpressionElementType"
      minOccurs="0" maxOccurs="unbounded"/>
  </xs:sequence>
  <xs:attributeGroup ref="DTS:BasePropertyAttributeGroup"/>
  <xs:attributeGroup ref="DTS:ForEachVariableMappingAttributeGroup"/>
</xs:complexType>
```

The following table provides additional information about the elements, types, and constraints in the **ForEachVariableMappingType** complex type.

Element	Additional constraints	Type definition	Description
PropertyExpression	Additional constraints exist for the	PropertyExpressionElementType	The PropertyExpression

Element	Additional constraints	Type definition	Description
	PropertyExpression element. These constraints MUST be followed.		element serves the same purpose as specified for the Property element except that an expression that is evaluated at runtime is contained in the element's value that is stored in the Microsoft® SQL Server® Integration Services (SSIS) file format.

The following table provides additional information about the attributes, attribute groups, and types for the **ForEachVariableMappingType** complex type.

Attribute	Description
BasePropertyAttributeGroup	An attribute group that specifies attributes that are common to many different types throughout the schema.
ForEachVariableMappingAttributeGroup	An attribute group that specifies attributes for the ForEachVariableMappingType complex type.

2.5.2.1.1 ForEachVariableMappingAttributeGroup

The **ForEachVariableMappingAttributeGroup** attribute group contains the attributes for the [ForEachVariableMappingType](#) type.

The following is the XSD for the **ForEachVariableMappingAttributeGroup** attribute group.

```
<xs:attributeGroup name="ForEachVariableMappingAttributeGroup">
  <xs:attribute name="VariableName" type="xs:string" use="required"
    form="qualified"/>
  <xs:attribute name="ValueIndex" type="xs:int" use="required"
    form="qualified"/>
</xs:attributeGroup>
```

The following table specifies the attributes for the **ForEachVariableMappingAttributeGroup** attribute group.

Attribute	Description
VariableName	A string value that specifies the name of the variable to be mapped to the For...Each loop.
ValueIndex	An integer value that expresses the order of the variables. 0 based.

2.5.3 AnyNonPackageExecutableAttributeGroup

The **AnyNonPackageExecutableAttributeGroup** attribute group contains the attributes for the [AnyNonPackageExecutableType](#) type.

The following is the XSD for the **AnyNonPackageExecutableAttributeGroup** attribute group.

```
<xs:attributeGroup name="AnyNonPackageExecutableAttributeGroup">
  <!--Pipeline & Tasks use these attributes-->
  <xs:attribute name="ExecutionLocation" type="xs:int" default="0"
    use="optional" form="qualified"/>
  <xs:attribute name="ExecutionAddress" type="xs:string" default=""
    use="optional" form="qualified"/>
  <xs:attribute name="TaskContact" type="xs:string" default=""
    use="optional" form="qualified"/>
  <!--ForLoop uses these attributes-->
  <xs:attribute name="InitExpression" type="xs:string" default=""
    use="optional" form="qualified"/>
  <xs:attribute name="EvalExpression" type="xs:string" use="optional"
    form="qualified"/>
  <xs:attribute name="AssignExpression" type="xs:string" default=""
    use="optional" form="qualified"/>
  <!--ForLoop and ForEachLoop use this attribute-->
  <xs:attribute name="MaxConcurrent" type="xs:int" default="1"
    use="optional" form="qualified"/>
  <!--Sequence uses this attribute-->
  <xs:attribute name="LockName" type="xs:string" default=""
    use="optional" form="qualified"/>
</xs:attributeGroup>
```

The following table specifies the attributes for the **AnyNonPackageExecutableAttributeGroup** attribute group.

Attribute	Description
ExecutionLocation	An integer value. This value SHOULD be set to 0. <21>
ExecutionAddress	An integer value. This value SHOULD be set to EMPTY. <22>
TaskContact	A string value that holds information about the contact point for this package. Intended to be helpful in support of the package. This attribute MAY NOT be used for any executable of type AnyNonPackageExecutableType . The use of this value MUST depend on the value of the attribute on the ExecutableType Executable element. For more information about which ExecutableType executables MAY NOT have this attribute value specified, see ExecutableType Attribute Values for Different Executable Types .
InitExpression	A string value that specifies an expression to initialize a loop. This attribute MAY NOT be used for any executable of type AnyNonPackageExecutableType . The use of the InitExpression value MUST depend on the value of the attribute on the ExecutableType Executable element. For more information about which ExecutableType executables MAY NOT have this attribute value specified, see ExecutableType Attribute Values for Different Executable Types .
EvalExpression	A string value that specifies an expression to evaluate to determine whether a loop continues to execute. This attribute MAY NOT be used for any executable of type AnyNonPackageExecutableType . The use of this value MUST depend on the

Attribute	Description
	value of the attribute on the ExecutableType Executable element. For more information about which ExecutableType executables MAY NOT have this attribute value specified, see ExecutableType Attribute Values for Different Executable Types
AssignExpression	A string value that specifies the expression to evaluate at the end of each iteration of the loop. This attribute MAY NOT be used for any executable of type AnyNonPackageExecutableType . The use of the AssignExpression value MUST depend on the value of the attribute on the ExecutableType Executable element. For more information about which ExecutableType executables MAY NOT have this attribute value specified, see ExecutableType Attribute Values for Different Executable Types.
MaxConcurrent	An integer value. This value SHOULD be set to 1. <23>
LockName	A string value. This value SHOULD be left blank. <24>

2.6 ExecutableType Attribute Values for Different Executables

The value of the **ExecutableType** attribute of the [Executable](#) element carries with it important constraints, which are not fully expressed in the XSD code fragments. These additional constraints MUST be followed for each value of the **ExecutableType** attribute. These additional constraints are explained in this section. The important differences that vary by value of the **ExecutableType** attribute are the following:

- Allowed values for the **Name** attribute of the **Property** element differ for different values of the **ExecutableType** attribute. The same limitations apply to the **PropertyExpression** element within the same **ExecutableType** instance.
- The choice that is contained within the complex type definition for [ExecutableObjectDataType](#) is also constrained by this value. Not all of the choices in the XSD are available for each **ExecutableType** attribute value.
- Some **ExecutableType** attribute values allow an **Executables** element to be contained within the current **Executable** element, and others do not allow an **Executables** element to be contained within the current **Executable** element.

2.6.1 ExecutableType Instance for Pipeline

An [Executable](#) element is a Pipeline executable if the **ExecutableType** attribute value is "SSIS.Pipeline" or "SSIS.Pipeline.2".

The Pipeline executable is formally specified to be of type [AnyNonPackageExecutableType](#). However, the following XSD fragment, which is expressed as an anonymous complex type declaration, places further restrictions on the type than the restrictions that are declared in the **AnyNonPackageExecutableType** type declaration. An **Executable** element with the **ExecutableType** attribute value equal to "SSIS.Pipeline" or "SSIS.Pipeline.2" MUST follow the anonymous type declaration that is contained in this section.

Note the following differences between this anonymous complex type declaration and the full definition of the complex type for the **AnyNonPackageExecutableType** type.

- This **Executable** element MUST NOT contain an **Executables** element.
- This **Executable** element MUST NOT contain a **ForEachEnumerators** element.

- This **Executable** element MUST NOT contain a **ForEachVariableMappings** element.
- In the **AnyNonPackageExecutableType** type, the type of the **ObjectData** element is given as [ExecutableObjectDataType](#). The **ExecutableObjectDataType** type definition contains an **xs:choice** XSD Schema element. However, for the Pipeline executable not all of the choices that are allowed in the **xs:choice** XSD Schema element are available. For this **Executable** element, the **ObjectData** element MUST contain the **pipeline** element of type [pipelineObjectDataType](#).
- The allowed attributes are a restricted subset of those that are allowed on the type, as specified in the [AnyNonPackageExecutableAttributeGroup](#) attribute group. Hence, the declaration of the attributes is replaced in this anonymous XSD fragment. The attributes used MUST be restricted to the ones that are shown as valid in the XSD fragment that is contained in this section.

For more information about the elements, attributes, and enumeration values in the following XSD fragment, see section [2.5.1](#).

```
<xs:complexType>
  <xs:sequence>
    <xs:element name="ForEachEnumerators"
      type="DTS:ForEachEnumeratorsType"
      minOccurs="0" maxOccurs="0"/>
    <xs:element name="Variables" type="DTS:VariablesType" minOccurs="0"/>
    <xs:element name="LoggingOptions" type="DTS:LoggingOptionsType" />
    <xs:element name="PropertyExpression"
      type="DTS:PropertyExpressionElementType" minOccurs="0"/>
    <xs:element name="PrecedenceConstraints"
      type="DTS:PrecedenceConstraintsType" minOccurs="0"/>
    <xs:element name="ForEachVariableMappings"
      type="DTS:ForEachVariableMappingsType"
      minOccurs="0" maxOccurs="0"/>
    <xs:element name="EventHandlers" type="DTS:EventHandlersType"
      minOccurs="0"/>
    <xs:element name="ObjectData">
      <xs:complexType>
        <xs:choice>
          <xs:element name="pipeline"
            type="DTS:pipelineObjectDataType"
            form="unqualified"/>
        </xs:choice>
      </xs:complexType>
    </xs:element>
  </xs:sequence>
  <xs:attribute name="ExecutableType" use="required">
    <xs:simpleType>
      <xs:restriction base="xs:string">
        <xs:enumeration value="SSIS.Pipeline.3"/>
        <xs:enumeration value="SSIS.Pipeline"/>
      </xs:restriction>
    </xs:simpleType>
  </xs:attribute>
  <xs:attribute name="ThreadHint" use="optional" type="xs:int"/>
  <xs:attributeGroup ref="DTS:BasePropertyAttributeGroup"/>
  <xs:attributeGroup ref="DTS:BaseExecutablePropertyAttributeGroup"/>
  <xs:attributeGroup ref="DTS:AllExecutableAttributeGroup"/>
  <xs:attribute name="ExecutionLocation" type="xs:int" default="0"
    use="optional" form="qualified"/>
  <xs:attribute name="ExecutionAddress" type="xs:string" default="">
```

```

        use="optional" form="qualified"/>
<xs:attribute name="TaskContact" type="xs:string" default=""
        use="optional" form="qualified"/>
</xs:complexType>

```

2.6.2 Executable Container Types

Executable container types are not a formal type within the XSD. They are a conceptual subdivision of the values for the **ExecutableType** attribute on the [Executable](#) element that is specified by the [AnyNonPackageExecutableType](#) type. The **Executable** elements that are specified in the following subsections can contain additional executables that are nested within an instance of themselves.

2.6.2.1 ExecutableType Instance for Sequence

An executable is a **Sequence executable** if the **ExecutableType** attribute value is "STOCK:SEQUENCE".

The Sequence executable is formally specified to be of type [AnyNonPackageExecutableType](#). However, the following XSD fragment, which is expressed as an anonymous complex type declaration, places further restrictions on the type than the restrictions that are declared in the **AnyNonPackageExecutableType** type declaration. An [Executable](#) element with the **ExecutableType** attribute value equal to "STOCK:SEQUENCE" MUST follow the anonymous type declaration that is contained in this section.

Note the following differences between this anonymous complex type declaration and the full definition of the complex type for the **AnyNonPackageExecutableType** type:

- This **Executable** element MUST NOT contain an **ObjectData** element.
- This **Executable** element MUST NOT contain a **ForEachEnumerator** element.
- This **Executable** element MUST NOT contain a **ForEachVariableMapping** element.
- This **Executable** element MUST NOT contain the **ThreadHint** attribute.
- The allowed attributes are a restricted subset of those that are allowed on the type, as specified in the [AnyNonPackageExecutableAttributeGroup](#) attribute group. Hence, the declaration of the attributes is replaced in this anonymous XSD fragment. The attributes used MUST be restricted to the ones that are shown as valid in the XSD fragment that is contained in this section.

```

<xs:complexType>
  <xs:sequence>
    <xs:element name="ForEachEnumerators"
      type="DTS:ForEachEnumeratorsType"
      minOccurs="0" maxOccurs="0"/>
    <xs:element name="Variables" type="DTS:VariablesType" minOccurs="0"/>
    <xs:element name="LoggingOptions" type="DTS:LoggingOptionsType" />
    <xs:element name="PropertyExpression"
      type="DTS:PropertyExpressionElementType" minOccurs="0"/>
    <xs:element name="Executables" type="DTS:ExecutablesType"
      minOccurs="0" maxOccurs="unbounded"/>
    <xs:element name="PrecedenceConstraints"
      type="DTS:PrecedenceConstraintsType" minOccurs="0"/>
    <xs:element name="ForEachVariableMappings"
      type="DTS:ForEachVariableMappingsType"

```

```

        minOccurs="0" maxOccurs="0"/>
    <xs:element name="EventHandlers" type="DTS:EventHandlersType"
        minOccurs="0"/>
    <xs:choice minOccurs="0" maxOccurs="0">
        <xs:element name="ObjectData"/>
    </xs:choice>
</xs:sequence>
<xs:attribute name="ExecutableType" use="required"
    fixed="STOCK:SEQUENCE"/>
<xs:attributeGroup ref="DTS:AllExecutableAttributeGroup"/>
<xs:attribute name="LockName" type="xs:string" use="optional"
    default="" form="qualified"/>
</xs:complexType>

```

2.6.2.2 ExecutableType Instance for ForEachLoop

An executable is a **ForEach executable** if the **ExecutableType** attribute value is "STOCK:FOREACHLOOP".

The ForEach executable is formally defined to be of type [AnyNonPackageExecutableType](#). However, the following XSD fragment, which is expressed as an anonymous complex type declaration, places further restrictions on the type than the restrictions that are declared in the **AnyNonPackageExecutableType** type declaration. An [Executable](#) element with the **ExecutableType** attribute value equal to "STOCK:FOREACHLOOP" MUST follow the anonymous type declaration that is contained in this section.

Note the following differences between this anonymous complex type declaration and the full definition of the complex type for the **AnyNonPackageExecutableType** type:

- This **Executable** element MUST NOT contain an **ObjectData** element.
- This **Executable** element MUST NOT contain the **ThreadHint** attribute.
- The allowed attributes are a restricted subset of those that are allowed on the type, as specified in the [AnyNonPackageExecutableAttributeGroup](#) attribute group. Hence, the declaration of the attributes is replaced in this anonymous XSD fragment. The attributes used MUST be restricted to the ones that are shown as valid in the XSD fragment that is contained in this section.

```

<xs:complexType>
  <xs:sequence>
    <xs:element name="ForEachEnumerator"
        type="DTS:ForEachEnumeratorType"
        minOccurs="1" maxOccurs="unbounded"/>
    <xs:element name="Variables" type="DTS:VariablesType" minOccurs="0"/>
    <xs:element name="LoggingOptions" type="DTS:LoggingOptionsType" />
    <xs:element name="PropertyExpression"
        type="DTS:PropertyExpressionElementType" minOccurs="0"/>
    <xs:element name="Executables" type="DTS:ExecutablesType"
        minOccurs="0" maxOccurs="unbounded"/>
    <xs:element name="PrecedenceConstraints"
        type="DTS:PrecedenceConstraintsType" minOccurs="0"/>
    <xs:element name="ForEachVariableMappings"
        type="DTS:ForEachVariableMappingsType"
        minOccurs="1" maxOccurs="unbounded"/>
    <xs:element name="EventHandlers" type="DTS:EventHandlersType"

```



```

        minOccurs="0"/>
    <xs:choice minOccurs="0" maxOccurs="0">
        <xs:element name="ObjectData"/>
    </xs:choice>
</xs:sequence>
<xs:attribute name="ExecutableType" use="required"
    fixed="STOCK:FOREACHLOOP"/>
<xs:attributeGroup ref="DTS:AllExecutableAttributeGroup"/>
<xs:attribute name="MaxConcurrent" type="xs:int" use="optional"
    default="1" form="qualified"/>
</xs:complexType>

```

2.6.2.3 ExecutableType Instance for ForLoop

An executable is a ForLoop executable if the **ExecutableType** attribute value is "STOCK:FORLOOP".

The ForLoop executable is formally defined to be of type [AnyNonPackageExecutableType](#). However, the following XSD fragment, which is expressed as an anonymous complex type declaration, places further restrictions on the type than the restrictions that are declared in the **AnyNonPackageExecutableType** type declaration. An [Executable](#) element with the **ExecutableType** attribute value equal to "STOCK:FORLOOP" MUST follow the anonymous type declaration that is contained in this section.

Note the following differences between this anonymous complex type declaration and the full definition of the complex type for the **AnyNonPackageExecutableType** type:

- This **Executable** element MUST NOT contain an **ObjectData** element.
- This **Executable** element MUST NOT contain a **ForEachEnumerator** element.
- This **Executable** element MUST NOT contain a **ForEachVariableMapping** element.
- This **Executable** element MUST NOT contain the **ThreadHint** attribute.
- The allowed attributes are a restricted subset of those that are allowed on the type, as specified in the [AnyNonPackageExecutableAttributeGroup](#) attribute group. Hence, the declaration of the attributes is replaced in this anonymous XSD fragment. The attributes used MUST be restricted to the ones that are shown as valid in the XSD fragment that is contained in this section.

```

<xs:complexType>
  <xs:sequence>
    <xs:element name="ForEachEnumerator"
      type="DTS:ForEachEnumeratorType"
      minOccurs="0" maxOccurs="0"/>
    <xs:element name="Variables" type="DTS:VariablesType" minOccurs="0"/>
    <xs:element name="LoggingOptions" type="DTS:LoggingOptionsType" />
    <xs:element name="PropertyExpression"
      type="DTS:PropertyExpressionElementType" minOccurs="0"/>
    <xs:element name="Executables" type="DTS:ExecutablesType"
      minOccurs="0" maxOccurs="0"/>
    <xs:element name="PrecedenceConstraints"
      type="DTS:PrecedenceConstraintsType" minOccurs="0"/>
    <xs:element name="ForEachVariableMappings"
      type="DTS:ForEachVariableMappingsType"
      minOccurs="0" maxOccurs="0"/>
  
```

```

<xs:element name="EventHandlers" type="DTS:EventHandlersType"
            minOccurs="0"/>
<xs:choice minOccurs="0" maxOccurs="0">
  <xs:element name="ObjectData"/>
</xs:choice>
</xs:sequence>
<xs:attribute name="ExecutableType" use="required"
            fixed="STOCK:FORLOOP"/>
<xs:attributeGroup ref="DTS:AllExecutableAttributeGroup"/>
<xs:attribute name="InitExpression" type="xs:string" use="optional"
            default="" form="qualified"/>
<xs:attribute name="EvalExpression" type="xs:string" use="required"
            form="qualified"/>
<xs:attribute name="AssignExpression" type="xs:string" use="optional"
            default="" form="qualified"/>
<xs:attribute name="MaxConcurrent" type="xs:int" use="optional"
            default="1" form="qualified"/>
</xs:complexType>

```

2.6.3 Executable Task Types

Executable task types are not a formal type within the XSD. They are a conceptual subdivision of the values for the **ExecutableType** attribute on the [Executable](#) element that is specified by the [AnyNonPackageExecutableType](#) type. The **Executable** elements that are specified in the following subsections MUST NOT contain additional executables nested within an instance of themselves.

2.6.3.1 ExecutableType Instance for ActiveX Script Task

An executable is an ActiveX Script Task executable if the **ExecutableType** attribute value is "Microsoft.SqlServer.Dts.Tasks.ActiveXScriptTask.ActiveXScriptTask, Microsoft.SqlServer.ActiveXScriptTask, Version=11.0.0.0, Culture=neutral, PublicKeyToken=89845dcd8080cc91" or "STOCK:ActiveXScriptTask".

The ActiveX Script Task executable is formally defined to be of type [AnyNonPackageExecutableType](#). However, the following XSD fragment, which is expressed as an anonymous complex type declaration, places further restrictions on the type than the restrictions that are declared in the **AnyNonPackageExecutableType** type declaration. An [Executable](#) element with the **ExecutableType** attribute value equal to "Microsoft.SqlServer.Dts.Tasks.ActiveXScriptTask.ActiveXScriptTask, Microsoft.SqlServer.ActiveXScriptTask, Version=11.0.0.0, Culture=neutral, PublicKeyToken=89845dcd8080cc91" or "STOCK:ActiveXScriptTask" MUST follow the anonymous type declaration that is contained in this section.

Note the following differences between this anonymous complex type declaration and the full definition of the complex type for the **AnyNonPackageExecutableType** type:

- This **Executable** element MUST NOT contain an **Executable** element.
- This **Executable** element MUST NOT contain a **ForEachEnumerator** element.
- This **Executable** element MUST NOT contain a **ForEachVariableMapping** element.
- In the **AnyNonPackageExecutableType** type, the type of the **ObjectData** element is given as [ExecutableObjectDataType](#). The **ExecutableObjectDataType** type definition contains an **xs:choice** XSD Schema element. However, not all of the choices that are allowed in the **xs:choice** XSD Schema element are available for the ActiveX Script executable. For the ActiveX

Script executable element, the **ObjectData** element MUST contain the **ActiveXScriptTask:ActiveXScriptTaskData** element that is specified in the [ActiveXScriptTask](#) namespace.

- The allowed attributes are a restricted subset of those that are allowed on the type, as specified in the [AnyNonPackageExecutableAttributeGroup](#) attribute group. Hence, the declaration of the attributes is replaced in this anonymous XSD fragment. The attributes used MUST be restricted to the ones that are shown as valid in the XSD fragment that is contained in this section.

```

<xs:complexType>
  <xs:sequence>
    <xs:element name="ForEachEnumerators"
      type="DTS:ForEachEnumeratorsType"
      minOccurs="0" maxOccurs="0"/>
    <xs:element name="Variables" type="DTS:VariablesType" minOccurs="0"/>
    <xs:element name="LoggingOptions" type="DTS:LoggingOptionsType" />
    <xs:element name="PropertyExpression"
      type="DTS:PropertyExpressionElementType" minOccurs="0"/>
    <xs:element name="Executables" type="DTS:ExecutablesType"
      minOccurs="0" maxOccurs="0"/>
    <xs:element name="PrecedenceConstraints"
      type="DTS:PrecedenceConstraintsType" minOccurs="0"/>
    <xs:element name="ForEachVariableMappings"
      type="DTS:ForEachVariableMappingsType"
      minOccurs="0" maxOccurs="0"/>
    <xs:element name="EventHandlers" type="DTS:EventHandlersType"
      minOccurs="0"/>
    <xs:element name="ObjectData">
      <xs:complexType>
        <xs:choice>
          <xs:element ref="ActiveXScriptTask:ActiveXScriptTaskData" />
        </xs:choice>
      </xs:complexType>
    </xs:element>
  </xs:sequence>
  <xs:attribute name="ExecutableType" use="required">
    <xs:simpleType>
      <xs:restriction base="xs:string">
        <xs:enumeration
value="Microsoft.SqlServer.Dts.Tasks.ActiveXScriptTask.ActiveXScriptTask,
Microsoft.SqlServer.ActiveXScriptTask, Version=11.0.0.0, Culture=neutral,
PublicKeyToken=89845dcd8080cc91"/>
        <xs:enumeration value="STOCK:ActiveXScriptTask"/>
      </xs:restriction>
    </xs:simpleType>
  </xs:attribute>
  <xs:attribute name="ThreadHint" use="optional" type="xs:int"/>
  <xs:attributeGroup ref="DTS:BasePropertyAttributeGroup"/>
  <xs:attributeGroup ref="DTS:BaseExecutablePropertyAttributeGroup"/>
  <xs:attributeGroup ref="DTS:AllExecutableAttributeGroup"/>
  <xs:attribute name="ExecutionLocation" type="xs:int" default="0"
    use="optional" form="qualified"/>
  <xs:attribute name="ExecutionAddress" type="xs:string" default=""
    use="optional" form="qualified"/>
  <xs:attribute name="TaskContact" type="xs:string" default=""
    use="optional" form="qualified"/>
</xs:complexType>

```

2.6.3.1.1 TaskExeAttributeGroup

The **TaskExeAttributeGroup** attribute group is used by the anonymous type declarations that are described in the [Executable Task Types](#) section. This attribute group is not referenced anywhere in the formal XSD.

The following is the XSD for the **TaskExeAttributeGroup** attribute group.

```
<xs:attributeGroup name="TaskExeAttributeGroup">
  <xs:attribute name="ExecutionLocation" type="xs:int" default="0"
    use="optional" form="qualified"/>
  <xs:attribute name="ExecutionAddress" type="xs:string" default=""
    use="optional" form="qualified"/>
  <xs:attribute name="TaskContact" type="xs:string" default=""
    use="optional" form="qualified"/>
</xs:attributeGroup>
```

The interpretation of the attributes in the **TaskExeAttributeGroup** attribute group is given in [AnyNonPackageExecutableAttributeGroup](#).

2.6.3.2 ExecutableType Instance for AS Execute DDL Task

An executable is an Analysis Services (AS) Execute Data Definition Language (DDL) Task executable if the **ExecutableType** attribute value is "Microsoft.DataTransformationServices.Tasks.DTSProcessingTask.ASExecuteDDLTask, Microsoft.SqlServer.ASTasks, Version=11.0.0.0, Culture=neutral, PublicKeyToken=89845dcd8080cc91".

The AS Execute DDL task executable is formally defined to be of type [AnyNonPackageExecutableType](#). However, the following XSD fragment, which is expressed as an anonymous complex type declaration, places further restrictions on the type than the restrictions that are declared in the **AnyNonPackageExecutableType** type declaration. An [Executable](#) element with the **ExecutableType** attribute value equal to "Microsoft.DataTransformationServices.Tasks.DTSProcessingTask.ASExecuteDDLTask, Microsoft.SqlServer.ASTasks, Version=11.0.0.0, Culture=neutral, PublicKeyToken=89845dcd8080cc91" MUST follow the anonymous type declaration that is contained in this section.

Note the following differences between this anonymous complex type declaration and the full definition of the complex type for the **AnyNonPackageExecutableType** type:

- This **Executable** element MUST NOT contain an **Executables** element.
- This **Executable** element MUST NOT contain a **ForEachEnumerators** element.
- This **Executable** element MUST NOT contain a **ForEachVariableMappings** element.
- In the **AnyNonPackageExecutableType** type, the type of the **ObjectData** element is given as [ExecutableObjectDataType](#). The **ExecutableObjectDataType** type definition contains an **xs:choice** XSD Schema element. However, not all of the choices that are allowed in the **xs:choice** XSD Schema element are available for the AS Execute DDL executable. For this **Executable** element, the **ObjectData** element MUST contain the **ASDdlData** element of type [ASDdlDataObjectDataType](#).

- The allowed attributes are a restricted subset of those that are allowed on the type, as specified in the [AnyNonPackageExecutableAttributeGroup](#) attribute group. Hence, the declaration of the attributes is replaced in this anonymous XSD fragment. The attributes used MUST be restricted to the ones that are shown as valid in the XSD fragment that is contained in this section.

```

<xs:complexType>
  <xs:sequence>
    <xs:element name="ForEachEnumerators"
      type="DTS:ForEachEnumeratorsType"
      minOccurs="0" maxOccurs="0"/>
    <xs:element name="Variables" type="DTS:VariablesType" minOccurs="0"/>
    <xs:element name="LoggingOptions" type="DTS:LoggingOptionsType" />
    <xs:element name="PropertyExpression"
      type="DTS:PropertyExpressionElementType" minOccurs="0"/>
    <xs:element name="Executables" type="DTS:ExecutablesType"
      minOccurs="0" maxOccurs="0"/>
    <xs:element name="PrecedenceConstraints"
      type="DTS:PrecedenceConstraintsType" minOccurs="0"/>
    <xs:element name="ForEachVariableMappings"
      type="DTS:ForEachVariableMappingsType"
      minOccurs="0" maxOccurs="0"/>
    <xs:element name="EventHandlers" type="DTS:EventHandlersType"
      minOccurs="0"/>
    <xs:element name="ObjectData">
      <xs:complexType>
        <xs:choice>
          <xs:element name="ASDdlData" type="DTS:ASDdlDataObjectDataType"/>
        </xs:choice>
      </xs:complexType>
    </xs:element>
  </xs:sequence>
  <xs:attribute name="ExecutableType" use="required">
    <xs:simpleType>
      <xs:restriction base="xs:string">
        <xs:enumeration
value="Microsoft.DataTransformationServices.Tasks.DTSProcessingTask.ASExecuteDDLTask,
Microsoft.SqlServer.ASTasks, Version=11.0.0.0, Culture=neutral,
PublicKeyToken=89845dcd8080cc91"/>
      </xs:restriction>
    </xs:simpleType>
  </xs:attribute>
  <xs:attribute name="ThreadHint" use="optional" type="xs:int"/>
  <xs:attributeGroup ref="DTS:BasePropertyAttributeGroup"/>
  <xs:attributeGroup ref="DTS:BaseExecutablePropertyAttributeGroup"/>
  <xs:attributeGroup ref="DTS:AllExecutableAttributeGroup"/>
  <xs:attribute name="ExecutionLocation" type="xs:int" default="0"
use="optional" form="qualified"/>
  <xs:attribute name="ExecutionAddress" type="xs:string" default=""
use="optional" form="qualified"/>
  <xs:attribute name="TaskContact" type="xs:string" default=""
use="optional" form="qualified"/>
</xs:complexType>

```

2.6.3.3 ExecutableType Instance for AS Processing Task

An executable is an AS Processing Task executable if the **ExecutableType** attribute value is "Microsoft.DataTransformationServices.Tasks.DTSProcessingTask.DTSProcessingTask,

Microsoft.SqlServer.ASTasks, Version=11.0.0.0, Culture=neutral, PublicKeyToken=89845dcd8080cc91".

The AS Processing task executable is formally defined to be of type [AnyNonPackageExecutableType](#). However, the following XSD fragment, which is expressed as an anonymous complex type declaration, places further restrictions on the type than the restrictions that are declared in the **AnyNonPackageExecutableType** type declaration. An [Executable](#) element with the **ExecutableType** attribute value equal to "Microsoft.DataTransformationServices.Tasks.DTSProcessingTask.DTSProcessingTask, Microsoft.SqlServer.ASTasks, Version=11.0.0.0, Culture=neutral, PublicKeyToken=89845dcd8080cc91" MUST follow the anonymous type declaration that is contained in this section.

Note the following differences between this anonymous complex type declaration and the full definition of the complex type for the **AnyNonPackageExecutableType** type:

- This **Executable** element MUST NOT contain an **Executables** element.
- This **Executable** element MUST NOT contain a **ForEachEnumerators** element.
- This **Executable** element MUST NOT contain a **ForEachVariableMappings** element.
- In the **AnyNonPackageExecutableType** type, the type of the **ObjectData** element is given as [ExecutableObjectDataType](#). The **ExecutableObjectDataType** type definition contains an **xs:choice** XSD Schema element. However, not all of the choices that are allowed in the **xs:choice** XSD Schema element are available for the AS Processing Task executable. For this **Executable** element, the **ObjectData** element MUST contain the **ASProcessingData** element of type [ASProcessingDataObjectDataType](#).
- The allowed attributes are a restricted subset of those that are allowed on the type, as specified in the [AnyNonPackageExecutableAttributeGroup](#) attribute group. Hence, the declaration of the attributes is replaced in this anonymous XSD fragment. The attributes used MUST be restricted to the ones that are shown as valid in the XSD fragment that is contained in this section.

```
<xs:complexType>
  <xs:sequence>
    <xs:element name="ForEachEnumerators"
      type="DTS:ForEachEnumeratorsType"
      minOccurs="0" maxOccurs="0"/>
    <xs:element name="Variables" type="DTS:VariablesType" minOccurs="0"/>
    <xs:element name="LoggingOptions" type="DTS:LoggingOptionsType" />
    <xs:element name="PropertyExpression"
      type="DTS:PropertyExpressionElementType" minOccurs="0"/>
    <xs:element name="Executables" type="DTS:ExecutablesType"
      minOccurs="0" maxOccurs="0"/>
    <xs:element name="PrecedenceConstraints"
      type="DTS:PrecedenceConstraintsType" minOccurs="0"/>
    <xs:element name="ForEachVariableMappings"
      type="DTS:ForEachVariableMappingsType"
      minOccurs="0" maxOccurs="0"/>
    <xs:element name="EventHandlers" type="DTS:EventHandlersType"
      minOccurs="0"/>
    <xs:element name="ObjectData">
      <xs:complexType>
        <xs:choice>
          <xs:element name="ASProcessingData"
```

```

        type="DTS:ASProcessingDataObjectDataType"/>
    </xs:choice>
</xs:complexType>
</xs:element>
</xs:sequence>
<xs:attribute name="ExecutableType" use="required">
    <xs:simpleType>
        <xs:restriction base="xs:string">
            <xs:enumeration
value="Microsoft.DataTransformationServices.Tasks.DTSProcessingTask.DTSProcessingTask,
Microsoft.SqlServer.ASTasks, Version=11.0.0.0, Culture=neutral,
PublicKeyToken=89845dcd8080cc91"/>
        </xs:restriction>
    </xs:simpleType>
</xs:attribute>
<xs:attribute name="ThreadHint" use="optional" type="xs:int"/>
<xs:attributeGroup ref="DTS:BasePropertyAttributeGroup"/>
<xs:attributeGroup ref="DTS:BaseExecutablePropertyAttributeGroup"/>
<xs:attributeGroup ref="DTS:AllExecutableAttributeGroup"/>
<xs:attribute name="ExecutionLocation" type="xs:int" default="0"
use="optional" form="qualified"/>
<xs:attribute name="ExecutionAddress" type="xs:string" default=""
use="optional" form="qualified"/>
<xs:attribute name="TaskContact" type="xs:string" default=""
use="optional" form="qualified"/>
</xs:complexType>

```

2.6.3.4 ExecutableType Instance for Bulk Insert Task

An executable is a Bulk Insert Task executable if the **ExecutableType** attribute value is "Microsoft.SqlServer.Dts.Tasks.BulkInsertTask.BulkInsertTask, Microsoft.SqlServer.BulkInsertTask, Version=11.0.0.0, Culture=neutral, PublicKeyToken=89845dcd8080cc91" or "STOCK:BulkInsertTask".

The Bulk Insert Task executable is formally defined to be of type [AnyNonPackageExecutableType](#). However, the following XSD fragment, which is expressed as an anonymous complex type declaration, places further restrictions on the type than the restrictions that are declared in the **AnyNonPackageExecutableType** type declaration. An [Executable](#) element with the **ExecutableType** attribute value equal to "Microsoft.SqlServer.Dts.Tasks.BulkInsertTask.BulkInsertTask, Microsoft.SqlServer.BulkInsertTask, Version=11.0.0.0, Culture=neutral, PublicKeyToken=89845dcd8080cc91" or "STOCK:BulkInsertTask" MUST follow the anonymous type declaration that is contained in this section.

Note the following differences between this anonymous complex type declaration and the full definition of the complex type for the **AnyNonPackageExecutableType** type:

- This **Executable** element MUST NOT contain an **Executables** element.
- This **Executable** element MUST NOT contain a **ForEachEnumerators** element.
- This **Executable** element MUST NOT contain a **ForEachVariableMappings** element.
- In the **AnyNonPackageExecutableType** type, the type of the **ObjectData** element is given as [ExecutableObjectDataType](#). The **ExecutableObjectDataType** type definition contains an **xs:choice** XSD Schema element. However, not all of the choices that are allowed in the **xs:choice** XSD Schema element are available for the Bulk Insert Task executable. For this

Executable element, the **ObjectData** element MUST contain the **BulkInsertTask:BulkInsertTaskData** element that is specified in the [BulkInsertTask](#) namespace.

- The allowed attributes are a restricted subset of those that are allowed on the type, as specified in the [AnyNonPackageExecutableAttributeGroup](#) attribute group. Hence, the declaration of the attributes is replaced in this anonymous XSD fragment. The attributes used MUST be restricted to the ones that are shown as valid in the XSD fragment that is contained in this section.

```

<xs:complexType>
  <xs:sequence>
    <xs:element name="ForEachEnumerators"
      type="DTS:ForEachEnumeratorsType"
      minOccurs="0" maxOccurs="0"/>
    <xs:element name="Variables" type="DTS:VariablesType" minOccurs="0"/>
    <xs:element name="LoggingOptions" type="DTS:LoggingOptionsType" />
    <xs:element name="PropertyExpression"
      type="DTS:PropertyExpressionElementType" minOccurs="0"/>
    <xs:element name="Executables" type="DTS:ExecutablesType"
      minOccurs="0" maxOccurs="0"/>
    <xs:element name="PrecedenceConstraints"
      type="DTS:PrecedenceConstraintsType" minOccurs="0"/>
    <xs:element name="ForEachVariableMappings"
      type="DTS:ForEachVariableMappingsType"
      minOccurs="0" maxOccurs="0"/>
    <xs:element name="EventHandlers" type="DTS:EventHandlersType"
      minOccurs="0"/>
    <xs:element name="ObjectData">
      <xs:complexType>
        <xs:choice>
          <xs:element ref="BulkInsertTask:BulkInsertTaskData"/>
        </xs:choice>
      </xs:complexType>
    </xs:element>
  </xs:sequence>
  <xs:attribute name="ExecutableType" use="required">
    <xs:simpleType>
      <xs:restriction base="xs:string">
        <xs:enumeration value="Microsoft.SqlServer.Dts.Tasks.BulkInsertTask.BulkInsertTask,
Microsoft.SqlServer.BulkInsertTask, Version=11.0.0.0, Culture=neutral,
PublicKeyToken=89845dcd8080cc91"/>
        <xs:enumeration value="STOCK:BulkInsertTask"/>
      </xs:restriction>
    </xs:simpleType>
  </xs:attribute>
  <xs:attribute name="ThreadHint" use="optional" type="xs:int"/>
  <xs:attributeGroup ref="DTS:BasePropertyAttributeGroup"/>
  <xs:attributeGroup ref="DTS:BaseExecutablePropertyAttributeGroup"/>
  <xs:attributeGroup ref="DTS:AllExecutableAttributeGroup"/>
  <xs:attribute name="ExecutionLocation" type="xs:int" default="0"
    use="optional" form="qualified"/>
  <xs:attribute name="ExecutionAddress" type="xs:string" default=""
    use="optional" form="qualified"/>
  <xs:attribute name="TaskContact" type="xs:string" default=""
    use="optional" form="qualified"/>
</xs:complexType>

```

2.6.3.5 ExecutableType Instance for Data Mining Query Task

An executable is a Data Mining Query Task executable if the **ExecutableType** attribute value is "Microsoft.SqlServer.Dts.Tasks.DMQueryTask.DMQueryTask, Microsoft.SqlServer.DMQueryTask, Version=11.0.0.0, Culture=neutral, PublicKeyToken=89845dcd8080cc91".

The Data Mining Query Task executable is formally defined to be of type [AnyNonPackageExecutableType](#). However, the following XSD fragment, which is expressed as an anonymous complex type declaration, places further restrictions on the type than the restrictions that are declared in the **AnyNonPackageExecutableType** type declaration. An [Executable](#) element with the **ExecutableType** attribute value equal to "Microsoft.SqlServer.Dts.Tasks.DMQueryTask.DMQueryTask, Microsoft.SqlServer.DMQueryTask, Version=11.0.0.0, Culture=neutral, PublicKeyToken=89845dcd8080cc91" MUST follow the anonymous type declaration that is contained in this section.

Note the following differences between this anonymous complex type declaration and the full definition of the complex type for the **AnyNonPackageExecutableType** type:

- This **Executable** element MUST NOT contain an **Executables** element.
- This **Executable** element MUST NOT contain a **ForEachEnumerators** element.
- This **Executable** element MUST NOT contain a **ForEachVariableMappings** element.
- In the **AnyNonPackageExecutableType** type, the type of the **ObjectData** element is given as [ExecutableObjectDataType](#). The **ExecutableObjectDataType** type definition contains an **xs:choice** XSD Schema element. However, not all of the choices that are allowed in the **xs:choice** XSD Schema element are available for the Data Mining Query Task executable. For this **Executable** element, the **ObjectData** element MUST contain the **DMQueryTaskData** element of type [DMQueryTaskDataObjectDataType](#).
- The allowed attributes are a restricted subset of those that are allowed on the type, as specified in the [AnyNonPackageExecutableAttributeGroup](#) attribute group. Hence, the declaration of the attributes is replaced in this anonymous XSD fragment. The attributes used MUST be restricted to the ones that are shown as valid in the XSD fragment that is contained in this section.

```
<xs:complexType>
  <xs:sequence>
    <xs:element name="ForEachEnumerators"
      type="DTS:ForEachEnumeratorsType"
      minOccurs="0" maxOccurs="0"/>
    <xs:element name="Variables" type="DTS:VariablesType" minOccurs="0"/>
    <xs:element name="LoggingOptions" type="DTS:LoggingOptionsType" />
    <xs:element name="PropertyExpression"
      type="DTS:PropertyExpressionElementType" minOccurs="0"/>
    <xs:element name="Executables" type="DTS:ExecutablesType"
      minOccurs="0" maxOccurs="0"/>
    <xs:element name="PrecedenceConstraints"
      type="DTS:PrecedenceConstraintsType" minOccurs="0"/>
    <xs:element name="ForEachVariableMappings"
      type="DTS:ForEachVariableMappingsType"
      minOccurs="0" maxOccurs="0"/>
    <xs:element name="EventHandlers" type="DTS:EventHandlersType"
      minOccurs="0"/>
    <xs:element name="ObjectData">
      <xs:complexType>
```

```

    <xs:choice>
      <xs:element name="DMQuertTaskData" form="unqualified"
        type="DTS:DMQueryTaskDataObjectDataType"/>
    </xs:choice>
  </xs:complexType>
</xs:element>
</xs:sequence>
<xs:attribute name="ExecutableType" use="required">
  <xs:simpleType>
    <xs:restriction base="xs:string">
      <xs:enumeration
        value="Microsoft.SqlServer.Dts.Tasks.DMQueryTask.DMQueryTask,
Microsoft.SqlServer.DMQueryTask, Version=11.0.0.0, Culture=neutral,
PublicKeyToken=89845dcd8080cc91"/>
    </xs:restriction>
  </xs:simpleType>
</xs:attribute>
<xs:attribute name="ThreadHint" use="optional" type="xs:int"/>
<xs:attributeGroup ref="DTS:BasePropertyAttributeGroup"/>
<xs:attributeGroup ref="DTS:BaseExecutablePropertyAttributeGroup"/>
<xs:attributeGroup ref="DTS:AllExecutableAttributeGroup"/>
<xs:attribute name="ExecutionLocation" type="xs:int" default="0"
  use="optional" form="qualified"/>
<xs:attribute name="ExecutionAddress" type="xs:string" default=""
  use="optional" form="qualified"/>
<xs:attribute name="TaskContact" type="xs:string" default=""
  use="optional" form="qualified"/>
</xs:complexType>

```

2.6.3.6 ExecutableType Instance for Data Profiling Task

An executable is a Data Profiling Task executable if the **ExecutableType** attribute value is "Microsoft.SqlServer.Dts.Tasks.DataProfilingTask.DataProfilingTask, Microsoft.SqlServer.DataProfilingTask, Version=11.0.0.0, Culture=neutral, PublicKeyToken=89845dcd8080cc91".

The Data Profiling Task executable is formally defined to be of type [AnyNonPackageExecutableType](#). However, the following XSD fragment, which is expressed as an anonymous complex type declaration, places further restrictions on the type than the restrictions that are declared in the **AnyNonPackageExecutableType** type declaration.

An [Executable](#) element with the **ExecutableType** attribute value equal to "Microsoft.SqlServer.Dts.Tasks.DataProfilingTask.DataProfilingTask, Microsoft.SqlServer.DataProfilingTask, Version=11.0.0.0, Culture=neutral, PublicKeyToken=89845dcd8080cc91" MUST follow the anonymous type declaration that is contained in this section.

Note the following differences between this anonymous complex type declaration and the full definition of the complex type for the **AnyNonPackageExecutableType** type:

- This **Executable** element MUST NOT contain an **Executables** element.
- This **Executable** element MUST NOT contain a **ForEachEnumerators** element.
- This **Executable** element MUST NOT contain a **ForEachVariableMappings** element.

- In the **AnyNonPackageExecutableType** type, the type of the **ObjectData** element is given as [ExecutableObjectDataType](#). The **ExecutableObjectDataType** type definition contains an **xs:choice** XSD Schema element. However, not all of the choices that are allowed in the **xs:choice** XSD Schema element are available for the Data Profiling Task executable. For this **Executable** element, the **ObjectData** element MUST contain the **DataProfilingTaskData** element of type [DataProfilingTaskDataObjectDataType](#).
- The allowed attributes are a restricted subset of those that are allowed on the type, as specified in the [AnyNonPackageExecutableAttributeGroup](#) attribute group. Hence, the declaration of the attributes is replaced in this anonymous XSD fragment. The attributes used MUST be restricted to the ones that are shown as valid in the XSD fragment that is contained in this section.

```

<xs:complexType>
  <xs:sequence>
    <xs:element name="ForEachEnumerators"
      type="DTS:ForEachEnumeratorsType"
      minOccurs="0" maxOccurs="0"/>
    <xs:element name="Variables" type="DTS:VariablesType" minOccurs="0"/>
    <xs:element name="LoggingOptions" type="DTS:LoggingOptionsType" />
    <xs:element name="PropertyExpression"
      type="DTS:PropertyExpressionElementType" minOccurs="0"/>
    <xs:element name="Executables" type="DTS:ExecutablesType"
      minOccurs="0" maxOccurs="0"/>
    <xs:element name="PrecedenceConstraints"
      type="DTS:PrecedenceConstraintsType" minOccurs="0"/>
    <xs:element name="ForEachVariableMappings"
      type="DTS:ForEachVariableMappingsType"
      minOccurs="0" maxOccurs="0"/>
    <xs:element name="EventHandlers" type="DTS:EventHandlersType"
      minOccurs="0"/>
    <xs:element name="ObjectData">
      <xs:complexType>
        <xs:choice>
          <xs:element name="DataProfilingTaskData" form="unqualified"
            type="DTS:DataProfilingTaskDataObjectDataType"/>
        </xs:choice>
      </xs:complexType>
    </xs:element>
  </xs:sequence>
  <xs:attribute name="ExecutableType" use="required">
    <xs:simpleType>
      <xs:restriction base="xs:string">
        <xs:enumeration
          value="Microsoft.SqlServer.Dts.Tasks.DataProfilingTask.DataProfilingTask,
            Microsoft.SqlServer.DataProfilingTask, Version=11.0.0.0, Culture=neutral,
            PublicKeyToken=89845dcd8080cc91"/>
      </xs:restriction>
    </xs:simpleType>
  </xs:attribute>
  <xs:attribute name="ThreadHint" use="optional" type="xs:int"/>
  <xs:attributeGroup ref="DTS:BasePropertyAttributeGroup"/>
  <xs:attributeGroup ref="DTS:BaseExecutablePropertyAttributeGroup"/>
  <xs:attributeGroup ref="DTS:AllExecutableAttributeGroup"/>
  <xs:attribute name="ExecutionLocation" type="xs:int" default="0"
    use="optional" form="qualified"/>
  <xs:attribute name="ExecutionAddress" type="xs:string" default=""
    use="optional" form="qualified"/>

```

```

    <xs:attribute name="TaskContact" type="xs:string" default=""
                use="optional" form="qualified"/>
</xs:complexType>

```

2.6.3.7 ExecutableType Instance for Execute DTS 2000 Package Task

An executable is a Execute DTS 2000 Package Task executable if the **ExecutableType** attribute value is "Microsoft.SqlServer.Dts.Tasks.Exec80PackageTask.Exec80PackageTask, Microsoft.SqlServer.Exec80PackageTask, Version=11.0.0.0, Culture=neutral, PublicKeyToken=89845dcd8080cc91" or "STOCK:Exec80PackageTask".

The Execute DTS 2000 Package Task executable is formally defined to be of type [AnyNonPackageExecutableType](#). However, the following XSD fragment, which is expressed as an anonymous complex type declaration, places further restrictions on the type than the restrictions that are declared in the **AnyNonPackageExecutableType** type declaration. An [Executable](#) element with the **ExecutableType** attribute value equal to "Microsoft.SqlServer.Dts.Tasks.Exec80PackageTask.Exec80PackageTask, Microsoft.SqlServer.Exec80PackageTask, Version=11.0.0.0, Culture=neutral, PublicKeyToken=89845dcd8080cc91" or "STOCK:Exec80PackageTask" MUST follow the anonymous type declaration that is contained in this section.

Note the following differences between this anonymous complex type declaration and the full definition of the complex type for the **AnyNonPackageExecutableType** type:

- This **Executable** element MUST NOT contain an **Executables** element.
- This **Executable** element MUST NOT contain a **ForEachEnumerators** element.
- This **Executable** element MUST NOT contain a **ForEachVariableMappings** element.
- In the **AnyNonPackageExecutableType** type, the type of the **ObjectData** element is given as [ExecutableObjectDataType](#). The **ExecutableObjectDataType** type definition contains an **xs:choice** XSD Schema element. However, not all of the choices that are allowed in the **xs:choice** XSD Schema element are available for the Execute DTS 2000 Package Task executable. For this **Executable** element, the **ObjectData** element MUST contain the [Exec80packageTaskData](#) element that is specified in the [Exec80PackageTask](#) namespace.
- The allowed attributes are a restricted subset of those that are allowed on the type, as specified in the [AnyNonPackageExecutableAttributeGroup](#) attribute group. Hence, the declaration of the attributes is replaced in this anonymous XSD fragment. The attributes used MUST be restricted to the ones that are shown as valid in the XSD fragment that is contained in this section.

```

<xs:complexType>
  <xs:sequence>
    <xs:element name="ForEachEnumerators"
              type="DTS:ForEachEnumeratorsType"
              minOccurs="0" maxOccurs="0"/>
    <xs:element name="Variables" type="DTS:VariablesType" minOccurs="0"/>
    <xs:element name="LoggingOptions" type="DTS:LoggingOptionsType" />
    <xs:element name="PropertyExpression"
              type="DTS:PropertyExpressionElementType" minOccurs="0"/>
    <xs:element name="Executables" type="DTS:ExecutablesType"
              minOccurs="0" maxOccurs="0"/>
    <xs:element name="PrecedenceConstraints"
              type="DTS:PrecedenceConstraintsType" minOccurs="0"/>
  
```

```

<xs:element name="ForEachVariableMappings"
  type="DTS:ForEachVariableMappingsType"
  minOccurs="0" maxOccurs="0"/>
<xs:element name="EventHandlers" type="DTS:EventHandlersType"
  minOccurs="0"/>
<xs:element name="ObjectData">
  <xs:complexType>
    <xs:choice>
      <xs:element ref="Exec80PackageTask:Exec80PackageTaskData"/>
    </xs:choice>
  </xs:complexType>
</xs:element>
</xs:sequence>
<xs:attribute name="ExecutableType" use="required">
  <xs:simpleType>
    <xs:restriction base="xs:string">
      <xs:enumeration
        value="Microsoft.SqlServer.Dts.Tasks.Exec80PackageTask.Exec80PackageTask,
Microsoft.SqlServer.Exec80PackageTask, Version=11.0.0.0, Culture=neutral,
PublicKeyToken=89845dcd8080cc91"/>
      <xs:enumeration value="STOCK:Exec80PackageTask"/>
    </xs:restriction>
  </xs:simpleType>
</xs:attribute>
<xs:attribute name="ThreadHint" use="optional" type="xs:int"/>
<xs:attributeGroup ref="DTS:BasePropertyAttributeGroup"/>
<xs:attributeGroup ref="DTS:BaseExecutablePropertyAttributeGroup"/>
<xs:attributeGroup ref="DTS:AllExecutableAttributeGroup"/>
<xs:attribute name="ExecutionLocation" type="xs:int" default="0"
  use="optional" form="qualified"/>
<xs:attribute name="ExecutionAddress" type="xs:string" default=""
  use="optional" form="qualified"/>
<xs:attribute name="TaskContact" type="xs:string" default=""
  use="optional" form="qualified"/>
</xs:complexType>

```

2.6.3.8 ExecutableType Instance for Execute Package Task

An executable is a Execute Package Task executable if the **ExecutableType** attribute value is "SSIS.ExecutePackageTask.2" or "STOCK:ExecutePackageTask".

The Execute Package Task executable is formally defined to be of type [AnyNonPackageExecutableType](#). However, the following XSD fragment, which is expressed as an anonymous complex type declaration, places further restrictions on the type than the restrictions that are declared in the **AnyNonPackageExecutableType** type declaration. An [Executable](#) element with the **ExecutableType** attribute value equal to "SSIS.ExecutePackageTask.2" or "STOCK:ExecutePackageTask" MUST follow the anonymous type declaration that is contained in this section.

Note the following differences between this anonymous complex type declaration and the full definition of the complex type for the **AnyNonPackageExecutableType** type:

- This **Executable** element MUST NOT contain an **Executables** element.
- This **Executable** element MUST NOT contain a **ForEachEnumerators** element.
- This **Executable** element MUST NOT contain a **ForEachVariableMappings** element.

- In the **AnyNonPackageExecutableType** type, the type of the **ObjectData** element is given as [ExecutableObjectDataType](#). The **ExecutableObjectDataType** type definition contains an **xs:choice** XSD Schema element. However, not all of the choices that are allowed in the **xs:choice** XSD Schema element are available for the Execute Package Task executable. For this **Executable** element, the **ObjectData** element MUST contain the **ExecutePackageTask** element of type [ExecutePackageTaskObjectDataType](#).
- The allowed attributes are a restricted subset of those that are allowed on the type, as specified in the [AnyNonPackageExecutableAttributeGroup](#) attribute group. Hence, the declaration of the attributes is replaced in this anonymous XSD fragment. The attributes used MUST be restricted to the ones that are shown as valid in the XSD fragment that is contained in this section.

```

<xs:complexType>
  <xs:sequence>
    <xs:element name="ForEachEnumerators"
      type="DTS:ForEachEnumeratorsType"
      minOccurs="0" maxOccurs="0"/>
    <xs:element name="Variables" type="DTS:VariablesType" minOccurs="0"/>
    <xs:element name="LoggingOptions" type="DTS:LoggingOptionsType" />
    <xs:element name="PropertyExpression"
      type="DTS:PropertyExpressionElementType" minOccurs="0"/>
    <xs:element name="Executables" type="DTS:ExecutablesType"
      minOccurs="0" maxOccurs="0"/>
    <xs:element name="PrecedenceConstraints"
      type="DTS:PrecedenceConstraintsType" minOccurs="0"/>
    <xs:element name="ForEachVariableMappings"
      type="DTS:ForEachVariableMappingsType"
      minOccurs="0" maxOccurs="0"/>
    <xs:element name="EventHandlers" type="DTS:EventHandlersType"
      minOccurs="0"/>
    <xs:element name="ObjectData">
      <xs:complexType>
        <xs:choice>
          <xs:element name="ExecutePackageTask" form="unqualified"
            type="DTS:ExecutePackageTaskObjectDataType"/>
        </xs:choice>
      </xs:complexType>
    </xs:element>
  </xs:sequence>
  <xs:attribute name="ExecutableType" use="required">
    <xs:simpleType>
      <xs:restriction base="xs:string">
        <xs:enumeration
          value="SSIS.ExecutePackageTask.2"/>
        <xs:enumeration value="STOCK.ExecutePackageTask"/>
      </xs:restriction>
    </xs:simpleType>
  </xs:attribute>
  <xs:attribute name="ThreadHint" use="optional" type="xs:int"/>
  <xs:attributeGroup ref="DTS:BasePropertyAttributeGroup"/>
  <xs:attributeGroup ref="DTS:BaseExecutablePropertyAttributeGroup"/>
  <xs:attributeGroup ref="DTS:AllExecutableAttributeGroup"/>
  <xs:attribute name="ExecutionLocation" type="xs:int" default="0"
    use="optional" form="qualified"/>
  <xs:attribute name="ExecutionAddress" type="xs:string" default=""
    use="optional" form="qualified"/>
  <xs:attribute name="TaskContact" type="xs:string" default=""

```

```

        use="optional" form="qualified"/>
</xs:complexType>

```

2.6.3.9 ExecutableType Instance for Execute Process Task

An executable is a Execute Process Task executable if the **ExecutableType** attribute value is "Microsoft.SqlServer.Dts.Tasks.ExecuteProcess.ExecuteProcess, Microsoft.SqlServer.ExecProcTask, Version=11.0.0.0, Culture=neutral, PublicKeyToken=89845dcd8080cc91" or "STOCK:ExecuteProcessTask".

The Execute Process Task executable is formally defined to be of type [AnyNonPackageExecutableType](#). However, the following XSD fragment, which is expressed as an anonymous complex type declaration, places further restrictions on the type than the restrictions that are declared in the **AnyNonPackageExecutableType** type declaration. An [Executable](#) element with the **ExecutableType** attribute value equal to "Microsoft.SqlServer.Dts.Tasks.ExecuteProcess.ExecuteProcess, Microsoft.SqlServer.ExecProcTask, Version=11.0.0.0, Culture=neutral, PublicKeyToken=89845dcd8080cc91" or "STOCK:ExecuteProcessTask" MUST follow the anonymous type declaration that is contained in this section.

Note the following differences between this anonymous complex type declaration and the full definition of the complex type for the **AnyNonPackageExecutableType** type:

- This **Executable** element MUST NOT contain an **Executables** element.
- This **Executable** element MUST NOT contain a **ForEachEnumerators** element.
- This **Executable** element MUST NOT contain a **ForEachVariableMappings** element.
- In the **AnyNonPackageExecutableType** type, the type of the **ObjectData** element is given as [ExecutableObjectDataType](#). The **ExecutableObjectDataType** type definition contains an **xs:choice** XSD Schema element. However, not all of the choices that are allowed in the **xs:choice** XSD Schema element are available for the Execute Process Task executable. For this **Executable** element, the **ObjectData** element MUST contain the **ExecuteProcessData** element of type [ExecuteProcessDataObjectDataType](#).
- The allowed attributes are a restricted subset of those that are allowed on the type, as specified in the [AnyNonPackageExecutableAttributeGroup](#) attribute group. Hence, the declaration of the attributes is replaced in this anonymous XSD fragment. The attributes used MUST be restricted to the ones that are shown as valid in the XSD fragment that is contained in this section.

```

<xs:complexType>
  <xs:sequence>
    <xs:element name="ForEachEnumerators"
      type="DTS:ForEachEnumeratorsType"
      minOccurs="0" maxOccurs="0"/>
    <xs:element name="Variables" type="DTS:VariablesType" minOccurs="0"/>
    <xs:element name="LoggingOptions" type="DTS:LoggingOptionsType" />
    <xs:element name="PropertyExpression"
      type="DTS:PropertyExpressionElementType" minOccurs="0"/>
    <xs:element name="Executables" type="DTS:ExecutablesType"
      minOccurs="0" maxOccurs="0"/>
    <xs:element name="PrecedenceConstraints"
      type="DTS:PrecedenceConstraintsType" minOccurs="0"/>
    <xs:element name="ForEachVariableMappings"

```

```

        type="DTS:ForEachVariableMappingsType"
        minOccurs="0" maxOccurs="0"/>
<xs:element name="EventHandlers" type="DTS:EventHandlersType"
minOccurs="0"/>
<xs:element name="ObjectData">
  <xs:complexType>
    <xs:choice>
      <xs:element name="ExecuteProcessData" form="unqualified"
type="DTS:ExecuteProcessDataObjectDataType"/>
    </xs:choice>
  </xs:complexType>
</xs:element>
</xs:sequence>
<xs:attribute name="ExecutableType" use="required">
  <xs:simpleType>
    <xs:restriction base="xs:string">
      <xs:enumeration
value="Microsoft.SqlServer.Dts.Tasks.ExecuteProcess.ExecuteProcess,
Microsoft.SqlServer.ExecProcTask, Version=11.0.0.0, Culture=neutral,
PublicKeyToken=89845dcd8080cc91"/>
      <xs:enumeration value="STOCK:ExecuteProcessTask"/>
    </xs:restriction>
  </xs:simpleType>
</xs:attribute>
<xs:attribute name="ThreadHint" use="optional" type="xs:int"/>
<xs:attributeGroup ref="DTS:BasePropertyAttributeGroup"/>
<xs:attributeGroup ref="DTS:BaseExecutablePropertyAttributeGroup"/>
<xs:attributeGroup ref="DTS:AllExecutableAttributeGroup"/>
<xs:attribute name="ExecutionLocation" type="xs:int" default="0"
use="optional" form="qualified"/>
<xs:attribute name="ExecutionAddress" type="xs:string" default=""
use="optional" form="qualified"/>
<xs:attribute name="TaskContact" type="xs:string" default=""
use="optional" form="qualified"/>
</xs:complexType>

```

2.6.3.10 ExecutableType Instance for Execute SQL Task

An executable is an Execute SQL Task executable if the **ExecutableType** attribute value is "Microsoft.SqlServer.Dts.Tasks.ExecuteSQLTask.ExecuteSQLTask, Microsoft.SqlServer.SQLTask, Version=11.0.0.0, Culture=neutral, PublicKeyToken=89845dcd8080cc91" or "STOCK:SQLTask".

The Execute SQL Task executable is formally defined to be of type [AnyNonPackageExecutableType](#). However, the following XSD fragment, which is expressed as an anonymous complex type declaration, places further restrictions on the type than the restrictions that are declared in the **AnyNonPackageExecutableType** type declaration. An [Executable](#) element with the **ExecutableType** attribute value equal to "Microsoft.SqlServer.Dts.Tasks.ExecuteSQLTask.ExecuteSQLTask, Microsoft.SqlServer.SQLTask, Version=11.0.0.0, Culture=neutral, PublicKeyToken=89845dcd8080cc91" or "STOCK:SQLTask" MUST follow the anonymous type declaration that is contained in this section.

Note the following differences between this anonymous complex type declaration and the full definition of the complex type for the **AnyNonPackageExecutableType** type:

- This **Executable** element MUST NOT contain an **Executables** element.
- This **Executable** element MUST NOT contain a **ForEachEnumerators** element.

- This **Executable** element MUST NOT contain a **ForEachVariableMappings** element.
- In the **AnyNonPackageExecutableType** type, the type of the **ObjectData** element is given as [ExecutableObjectDataType](#). The **ExecutableObjectDataType** type definition contains an **xs:choice** XSD Schema element. However, not all of the choices that are allowed in the **xs:choice** XSD Schema element are available for the Execute SQL Task executable. For this **Executable** element, the **ObjectData** element MUST contain the [SqlTaskData](#) element that is specified in the [SQLTask](#) namespace. The **SqlTaskData** element declaration in the **SQLTask** namespace MUST be replaced by the declaration and type that is specified in this section. This instance of the **SqlTaskData** element MUST contain zero elements and MUST NOT contain attributes other than those that are specified in the [SqlTaskBaseAttributeGroup](#) attribute group.
- The allowed attributes are a restricted subset of those that are allowed on the type, as specified in the [AnyNonPackageExecutableAttributeGroup](#) attribute group. Hence, the declaration of the attributes is replaced in this anonymous XSD fragment. The attributes used MUST be restricted to the ones that are shown as valid in the XSD fragment that is contained in this section.

```

<xs:complexType>
  <xs:sequence>
    <xs:element name="ForEachEnumerators"
      type="DTS:ForEachEnumeratorsType"
      minOccurs="0" maxOccurs="0"/>
    <xs:element name="Variables" type="DTS:VariablesType" minOccurs="0"/>
    <xs:element name="LoggingOptions" type="DTS:LoggingOptionsType" />
    <xs:element name="PropertyExpression"
      type="DTS:PropertyExpressionElementType" minOccurs="0"/>
    <xs:element name="Executables" type="DTS:ExecutablesType"
      minOccurs="0" maxOccurs="0"/>
    <xs:element name="PrecedenceConstraints"
      type="DTS:PrecedenceConstraintsType" minOccurs="0"/>
    <xs:element name="ForEachVariableMappings"
      type="DTS:ForEachVariableMappingsType"
      minOccurs="0" maxOccurs="0"/>
    <xs:element name="EventHandlers" type="DTS:EventHandlersType"
      minOccurs="0"/>
    <xs:element name="ObjectData">
      <xs:complexType>
        <xs:choice>
          <xs:element ref="SQLTask:SqlTaskData"/>
        </xs:choice>
      </xs:complexType>
    </xs:element>
  </xs:sequence>
  <xs:attribute name="ExecutableType" use="required">
    <xs:simpleType>
      <xs:restriction base="xs:string">
        <xs:enumeration
          value="Microsoft.SqlServer.Dts.Tasks.ExecuteSQLTask.ExecuteSQLTask,
Microsoft.SqlServer.SQLTask, Version=11.0.0.0, Culture=neutral,
PublicKeyToken=89845dcd8080cc91"/>
        <xs:enumeration value="STOCK:SQLTask"/>
      </xs:restriction>
    </xs:simpleType>
  </xs:attribute>
  <xs:attribute name="ThreadHint" use="optional" type="xs:int"/>
  <xs:attributeGroup ref="DTS:BasePropertyAttributeGroup"/>
  <xs:attributeGroup ref="DTS:BaseExecutablePropertyAttributeGroup"/>

```

```

<xs:attributeGroup ref="DTS:AllExecutableAttributeGroup"/>
<xs:attribute name="ExecutionLocation" type="xs:int" default="0"
  use="optional" form="qualified"/>
<xs:attribute name="ExecutionAddress" type="xs:string" default=""
  use="optional" form="qualified"/>
<xs:attribute name="TaskContact" type="xs:string" default=""
  use="optional" form="qualified"/>
</xs:complexType>

```

The preceding anonymous complex type definition requires that the declaration for the **SqlTaskData** element and its type, in the **SQLTask** namespace, be changed to the following.

```

<xs:element name="SqlTaskData"
  type="SQLTask:SqlTaskDataElementSqlTaskType"/>
<xs:complexType name="SqlTaskDataElementSqlTaskType">
  <xs:sequence/>
  <xs:attributeGroup
    ref="SQLTask:SqlTaskBaseAttributeGroup"/>
</xs:complexType>

```

2.6.3.11 ExecutableType Instance for File System Task

An executable is a File System Task executable if the **ExecutableType** attribute value is "Microsoft.SqlServer.Dts.Tasks.FileSystemTask.FileSystemTask, Microsoft.SqlServer.FileSystemTask, Version=11.0.0.0, Culture=neutral, PublicKeyToken=89845dcd8080cc91" or "STOCK:FileSystemTask".

The File System Task executable is formally defined to be of type [AnyNonPackageExecutableType](#). However, the following XSD fragment, which is expressed as an anonymous complex type declaration, places further restrictions on the type than the restrictions that are declared in the **AnyNonPackageExecutableType** type declaration. An [Executable](#) element with the **ExecutableType** attribute value equal to "Microsoft.SqlServer.Dts.Tasks.FileSystemTask.FileSystemTask, Microsoft.SqlServer.FileSystemTask, Version=11.0.0.0, Culture=neutral, PublicKeyToken=89845dcd8080cc91" or "STOCK:FileSystemTask" MUST follow the anonymous type declaration that is contained in this section.

Note the following differences between this anonymous complex type declaration and the full definition of the complex type for the **AnyNonPackageExecutableType** type:

- This **Executable** element MUST NOT contain an **Executables** element.
- This **Executable** element MUST NOT contain a **ForEachEnumerators** element.
- This **Executable** element MUST NOT contain a **ForEachVariableMappings** element.
- In the **AnyNonPackageExecutableType** type, the type of the **ObjectData** element is given as [ExecutableObjectDataType](#). The **ExecutableObjectDataType** type definition contains an **xs:choice** XSD Schema element. However, not all of the choices that are allowed in the **xs:choice** XSD Schema element are available for the File System Task executable. For this **Executable** element, the **ObjectData** element MUST contain the **FileSystemData** element of type [FileSystemDataObjectDataType](#).

- The allowed attributes are a restricted subset of those that are allowed on the type, as specified in the [AnyNonPackageExecutableAttributeGroup](#) attribute group. Hence, the declaration of the attributes is replaced in this anonymous XSD fragment. The attributes used MUST be restricted to the ones that are shown as valid in the XSD fragment that is contained in this section.

```

<xs:complexType>
  <xs:sequence>
    <xs:element name="ForEachEnumerators"
      type="DTS:ForEachEnumeratorsType"
      minOccurs="0" maxOccurs="0"/>
    <xs:element name="Variables" type="DTS:VariablesType" minOccurs="0"/>
    <xs:element name="LoggingOptions" type="DTS:LoggingOptionsType" />
    <xs:element name="PropertyExpression"
      type="DTS:PropertyExpressionElementType" minOccurs="0"/>
    <xs:element name="Executables" type="DTS:ExecutablesType"
      minOccurs="0" maxOccurs="0"/>
    <xs:element name="PrecedenceConstraints"
      type="DTS:PrecedenceConstraintsType" minOccurs="0"/>
    <xs:element name="ForEachVariableMappings"
      type="DTS:ForEachVariableMappingsType"
      minOccurs="0" maxOccurs="0"/>
    <xs:element name="EventHandlers" type="DTS:EventHandlersType"
      minOccurs="0"/>
    <xs:element name="ObjectData">
      <xs:complexType>
        <xs:choice>
          <xs:element name="FileSystemData" form="unqualified"
            type="DTS:FileSystemDataObjectData"/>
        </xs:choice>
      </xs:complexType>
    </xs:element>
  </xs:sequence>
  <xs:attribute name="ExecutableType" use="required">
    <xs:simpleType>
      <xs:restriction base="xs:string">
        <xs:enumeration
          value="Microsoft.SqlServer.Dts.Tasks.FileSystemTask.FileSystemTask,
Microsoft.SqlServer.FileSystemTask, Version=11.0.0.0, Culture=neutral,
PublicKeyToken=89845dcd8080cc91"/>
        <xs:enumeration value="STOCK:FileSystemTask"/>
      </xs:restriction>
    </xs:simpleType>
  </xs:attribute>
  <xs:attribute name="ThreadHint" use="optional" type="xs:int"/>
  <xs:attributeGroup ref="DTS:BasePropertyAttributeGroup"/>
  <xs:attributeGroup ref="DTS:BaseExecutablePropertyAttributeGroup"/>
  <xs:attributeGroup ref="DTS:AllExecutableAttributeGroup"/>
  <xs:attribute name="ExecutionLocation" type="xs:int" default="0"
    use="optional" form="qualified"/>
  <xs:attribute name="ExecutionAddress" type="xs:string" default=""
    use="optional" form="qualified"/>
  <xs:attribute name="TaskContact" type="xs:string" default=""
    use="optional" form="qualified"/>
</xs:complexType>

```

2.6.3.12 ExecutableType Instance for FTP Task

An executable is an FTP Task executable if the **ExecutableType** attribute value is "Microsoft.SqlServer.Dts.Tasks.FtpTask.FtpTask, Microsoft.SqlServer.FtpTask, Version=11.0.0.0, Culture=neutral, PublicKeyToken=89845dcd8080cc91" or "STOCK:FTPTask".

The FTP Task executable is formally defined to be of type [AnyNonPackageExecutableType](#). However, the following XSD fragment, which is expressed as an anonymous complex type declaration, places further restrictions on the type than the restrictions that are declared in the **AnyNonPackageExecutableType** type declaration. An [Executable](#) element with the **ExecutableType** attribute value equal to "Microsoft.SqlServer.Dts.Tasks.FtpTask.FtpTask, Microsoft.SqlServer.FtpTask, Version=11.0.0.0, Culture=neutral, PublicKeyToken=89845dcd8080cc91" or "STOCK:FTPTask" MUST follow the anonymous type declaration that is contained in this section.

Note the following differences between this anonymous complex type declaration and the full definition of the complex type for the **AnyNonPackageExecutableType** type:

- This **Executable** element MUST NOT contain an **Executables** element.
- This **Executable** element MUST NOT contain a **ForEachEnumerators** element.
- This **Executable** element MUST NOT contain a **ForEachVariableMappings** element.
- In the **AnyNonPackageExecutableType** type, the type of the **ObjectData** element is given as [ExecutableObjectDataType](#). The **ExecutableObjectDataType** type definition contains an **xs:choice** XSD Schema element. However, not all of the choices that are allowed in the **xs:choice** XSD Schema element are available for the FTP Task executable. For this **Executable** element, the **ObjectData** element MUST contain the **FtpData** element of type [FtpDataObjectDataType](#).
- The allowed attributes are a restricted subset of those that are allowed on the type, as specified in the [AnyNonPackageExecutableAttributeGroup](#) attribute group. Hence, the declaration of the attributes is replaced in this anonymous XSD fragment. The attributes used MUST be restricted to the ones that are shown as valid in the XSD fragment that is contained in this section.

```
<xs:complexType>
  <xs:sequence>
    <xs:element name="ForEachEnumerators"
      type="DTS:ForEachEnumeratorsType"
      minOccurs="0" maxOccurs="0"/>
    <xs:element name="Variables" type="DTS:VariablesType" minOccurs="0"/>
    <xs:element name="LoggingOptions" type="DTS:LoggingOptionsType" />
    <xs:element name="PropertyExpression"
      type="DTS:PropertyExpressionElementType" minOccurs="0"/>
    <xs:element name="Executables" type="DTS:ExecutablesType"
      minOccurs="0" maxOccurs="0"/>
    <xs:element name="PrecedenceConstraints"
      type="DTS:PrecedenceConstraintsType" minOccurs="0"/>
    <xs:element name="ForEachVariableMappings"
      type="DTS:ForEachVariableMappingsType"
      minOccurs="0" maxOccurs="0"/>
    <xs:element name="EventHandlers" type="DTS:EventHandlersType"
      minOccurs="0"/>
    <xs:element name="ObjectData">
      <xs:complexType>
```

```

    <xs:choice>
      <xs:element name="FtpData" type="DTS:FtpDataObjectDataType"
        form="unqualified"/>
    </xs:choice>
  </xs:complexType>
</xs:element>
</xs:sequence>
<xs:attribute name="ExecutableType" use="required">
  <xs:simpleType>
    <xs:restriction base="xs:string">
      <xs:enumeration
        value="Microsoft.SqlServer.Dts.Tasks.FtpTask.FtpTask, Microsoft.SqlServer.FtpTask,
Version=11.0.0.0, Culture=neutral, PublicKeyToken=89845dcd8080cc91"/>
      <xs:enumeration value="STOCK:FTPTask"/>
    </xs:restriction>
  </xs:simpleType>
</xs:attribute>
<xs:attribute name="ThreadHint" use="optional" type="xs:int"/>
<xs:attributeGroup ref="DTS:BasePropertyAttributeGroup"/>
<xs:attributeGroup ref="DTS:BaseExecutablePropertyAttributeGroup"/>
<xs:attributeGroup ref="DTS:AllExecutableAttributeGroup"/>
<xs:attribute name="ExecutionLocation" type="xs:int" default="0"
  use="optional" form="qualified"/>
<xs:attribute name="ExecutionAddress" type="xs:string" default=""
  use="optional" form="qualified"/>
<xs:attribute name="TaskContact" type="xs:string" default=""
  use="optional" form="qualified"/>
</xs:complexType>

```

2.6.3.13 ExecutableType Instance for Message Queue Task

An executable is a Message Queue Task executable if the **ExecutableType** attribute value is "Microsoft.SqlServer.Dts.Tasks.MessageQueueTask.MessageQueueTask, Microsoft.SqlServer.MSMQTask, Version=11.0.0.0, Culture=neutral, PublicKeyToken=89845dcd8080cc91" or "STOCK:MSMQTask".

The Message Queue Task executable is formally defined to be of type [AnyNonPackageExecutableType](#). However, the following XSD fragment, which is expressed as an anonymous complex type declaration, places further restrictions on the type than the restrictions that are declared in the **AnyNonPackageExecutableType** type declaration. An [Executable](#) element with the **ExecutableType** attribute value equal to "Microsoft.SqlServer.Dts.Tasks.MessageQueueTask.MessageQueueTask, Microsoft.SqlServer.MSMQTask, Version=11.0.0.0, Culture=neutral, PublicKeyToken=89845dcd8080cc91" or "STOCK:MSMQTask" MUST follow the anonymous type declaration that is contained in this section.

Note the following differences between this anonymous complex type declaration and the full definition of the complex type for the **AnyNonPackageExecutableType** type:

- This **Executable** element MUST NOT contain an **Executables** element.
- This **Executable** element MUST NOT contain a **ForEachEnumerators** element.
- This **Executable** element MUST NOT contain a **ForEachVariableMappings** element.
- In the **AnyNonPackageExecutableType** type, the type of the **ObjectData** element is given as [ExecutableObjectDataType](#). The **ExecutableObjectDataType** type definition contains an

xs:choice XSD Schema element. However, not all of the choices that are allowed in the **xs:choice** XSD Schema element are available for the Message Queue Task executable. For this **Executable** element, the **ObjectData** element MUST contain the [MessageQueueTaskData](#) element that is specified in the [MessageQueueTask](#) namespace.

- The allowed attributes are a restricted subset of those that are allowed on the type, as specified in the [AnyNonPackageExecutableAttributeGroup](#) attribute group. Hence, the declaration of the attributes is replaced in this anonymous XSD fragment. The attributes used MUST be restricted to the ones that are shown as valid in the XSD fragment that is contained in this section.

```

<xs:complexType>
  <xs:sequence>
    <xs:element name="ForEachEnumerators"
      type="DTS:ForEachEnumeratorsType"
      minOccurs="0" maxOccurs="0"/>
    <xs:element name="Variables" type="DTS:VariablesType" minOccurs="0"/>
    <xs:element name="LoggingOptions" type="DTS:LoggingOptionsType" />
    <xs:element name="PropertyExpression"
      type="DTS:PropertyExpressionElementType" minOccurs="0"/>
    <xs:element name="Executables" type="DTS:ExecutablesType"
      minOccurs="0" maxOccurs="0"/>
    <xs:element name="PrecedenceConstraints"
      type="DTS:PrecedenceConstraintsType" minOccurs="0"/>
    <xs:element name="ForEachVariableMappings"
      type="DTS:ForEachVariableMappingsType"
      minOccurs="0" maxOccurs="0"/>
    <xs:element name="EventHandlers" type="DTS:EventHandlersType"
      minOccurs="0"/>
    <xs:element name="ObjectData">
      <xs:complexType>
        <xs:choice>
          <xs:element ref="MessageQueueTask:MessageQueueTaskData"/>
        </xs:choice>
      </xs:complexType>
    </xs:element>
  </xs:sequence>
  <xs:attribute name="ExecutableType" use="required">
    <xs:simpleType>
      <xs:restriction base="xs:string">
        <xs:enumeration
          value="Microsoft.SqlServer.Dts.Tasks.MessageQueueTask.MessageQueueTask,
Microsoft.SqlServer.MSMQTask, Version=11.0.0.0, Culture=neutral,
PublicKeyToken=89845dcd8080cc91"/>
        <xs:enumeration value="STOCK:MSMQTask"/>
      </xs:restriction>
    </xs:simpleType>
  </xs:attribute>
  <xs:attribute name="ThreadHint" use="optional" type="xs:int"/>
  <xs:attributeGroup ref="DTS:BasePropertyAttributeGroup"/>
  <xs:attributeGroup ref="DTS:BaseExecutablePropertyAttributeGroup"/>
  <xs:attributeGroup ref="DTS:AllExecutableAttributeGroup"/>
  <xs:attribute name="ExecutionLocation" type="xs:int" default="0"
    use="optional" form="qualified"/>
  <xs:attribute name="ExecutionAddress" type="xs:string" default=""
    use="optional" form="qualified"/>
  <xs:attribute name="TaskContact" type="xs:string" default=""
    use="optional" form="qualified"/>

```

```
</xs:complexType>
```

2.6.3.14 ExecutableType Instance for Script Task

An executable is a Script Task executable if the **ExecutableType** attribute value is "Microsoft.SqlServer.Dts.Tasks.ScriptTask.ScriptTask, Microsoft.SqlServer.ScriptTask, Version=11.0.0.0, Culture=neutral, PublicKeyToken=89845dcd8080cc91" or "STOCK: ScriptTask".

The Script Task executable is formally defined to be of type [AnyNonPackageExecutableType](#). However, the following XSD fragment, which is expressed as an anonymous complex type declaration, places further restrictions on the type than the restrictions that are declared in the **AnyNonPackageExecutableType** type declaration. An [Executable](#) element with the **ExecutableType** attribute value equal to "Microsoft.SqlServer.Dts.Tasks.ScriptTask.ScriptTask, Microsoft.SqlServer.ScriptTask, Version=11.0.0.0, Culture=neutral, PublicKeyToken=89845dcd8080cc91" or "STOCK: ScriptTask" MUST follow the anonymous type declaration that is contained in this section.

Note the following differences between this anonymous complex type declaration and the full definition of the complex type for the **AnyNonPackageExecutableType** type:

- This **Executable** element MUST NOT contain an **Executables** element.
- This **Executable** element MUST NOT contain a **ForEachEnumerators** element.
- This **Executable** element MUST NOT contain a **ForEachVariableMappings** element.
- In the **AnyNonPackageExecutableType** type, the type of the **ObjectData** element is given as [ExecutableObjectDataType](#). The **ExecutableObjectDataType** type definition contains an **xs:choice** XSD Schema element. However, not all of the choices that are allowed in the **xs:choice** XSD Schema element are available for the Script Task executable. For this **Executable** element, the **ObjectData** element MUST contain the **ScriptProject** element of type [ScriptProjectObjectDataType](#).
- The allowed attributes are a restricted subset of those that are allowed on the type, as specified in the [AnyNonPackageExecutableAttributeGroup](#) attribute group. Hence, the declaration of the attributes is replaced in this anonymous XSD fragment. The attributes used MUST be restricted to the ones that are shown as valid in the XSD fragment that is contained in this section.

```
<xs:complexType>
  <xs:sequence>
    <xs:element name="ForEachEnumerators"
      type="DTS:ForEachEnumeratorsType"
      minOccurs="0" maxOccurs="0"/>
    <xs:element name="Variables" type="DTS:VariablesType" minOccurs="0"/>
    <xs:element name="LoggingOptions" type="DTS:LoggingOptionsType" />
    <xs:element name="PropertyExpression"
      type="DTS:PropertyExpressionElementType" minOccurs="0"/>
    <xs:element name="Executables" type="DTS:ExecutablesType"
      minOccurs="0" maxOccurs="0"/>
    <xs:element name="PrecedenceConstraints"
      type="DTS:PrecedenceConstraintsType" minOccurs="0"/>
    <xs:element name="ForEachVariableMappings"
      type="DTS:ForEachVariableMappingsType"
      minOccurs="0" maxOccurs="0"/>
    <xs:element name="EventHandlers" type="DTS:EventHandlersType"
```

```

        minOccurs="0"/>
<xs:element name="ObjectData">
  <xs:complexType>
    <xs:choice>
      <xs:element name="ScriptProject" type="DTS:ScriptProjectObjectType"
        form="unqualified"/>
    </xs:choice>
  </xs:complexType>
</xs:element>
</xs:sequence>
<xs:attribute name="ExecutableType" use="required">
  <xs:simpleType>
    <xs:restriction base="xs:string">
      <xs:enumeration
        value="Microsoft.SqlServer.Dts.Tasks.ScriptTask.ScriptTask,
Microsoft.SqlServer.ScriptTask, Version=11.0.0.0, Culture=neutral,
PublicKeyToken=89845dcd8080cc91"/>
      <xs:enumeration value="STOCK:ScriptTask"/>
    </xs:restriction>
  </xs:simpleType>
</xs:attribute>
<xs:attribute name="ThreadHint" use="optional" type="xs:int"/>
<xs:attributeGroup ref="DTS:BasePropertyAttributeGroup"/>
<xs:attributeGroup ref="DTS:BaseExecutablePropertyAttributeGroup"/>
<xs:attributeGroup ref="DTS:AllExecutableAttributeGroup"/>
<xs:attribute name="ExecutionLocation" type="xs:int" default="0"
  use="optional" form="qualified"/>
<xs:attribute name="ExecutionAddress" type="xs:string" default=""
  use="optional" form="qualified"/>
<xs:attribute name="TaskContact" type="xs:string" default=""
  use="optional" form="qualified"/>
</xs:complexType>

```

2.6.3.15 ExecutableType Instance for Send Mail Task

An executable is a Send Mail Task executable if the **ExecutableType** attribute value is "Microsoft.SqlServer.Dts.Tasks.SendMailTask.SendMailTask, Microsoft.SqlServer.SendMailTask, Version=11.0.0.0, Culture=neutral, PublicKeyToken=89845dcd8080cc91" or "STOCK:SendMailTask".

The Send Mail Task executable is formally defined to be of type [AnyNonPackageExecutableType](#). However, the following XSD fragment, which is expressed as an anonymous complex type declaration, places further restrictions on the type than the restrictions that are declared in the **AnyNonPackageExecutableType** type declaration. An [Executable](#) element with the **ExecutableType** attribute value equal to "Microsoft.SqlServer.Dts.Tasks.SendMailTask.SendMailTask, Microsoft.SqlServer.SendMailTask, Version=11.0.0.0, Culture=neutral, PublicKeyToken=89845dcd8080cc91" or "STOCK:SendMailTask" MUST follow the anonymous type declaration that is contained in this section.

Note the following differences between this anonymous complex type declaration and the full definition of the complex type for the **AnyNonPackageExecutableType** type:

- This **Executable** element MUST NOT contain an **Executables** element.
- This **Executable** element MUST NOT contain a **ForEachEnumerators** element.
- This **Executable** element MUST NOT contain a **ForEachVariableMappings** element.

- In the **AnyNonPackageExecutableType** type, the type of the **ObjectData** element is given as [ExecutableObjectDataType](#). The **ExecutableObjectDataType** type definition contains an **xs:choice** XSD Schema element. However, not all of the choices that are allowed in the **xs:choice** XSD Schema element are available for the Send Mail Task executable. For this **Executable** element, the **ObjectData** element MUST contain the [SendMailTaskData](#) element that is specified in the [SendMailTask](#) namespace.
- The allowed attributes are a restricted subset of those that are allowed on the type, as specified in the [AnyNonPackageExecutableAttributeGroup](#) attribute group. Hence, the declaration of the attributes is replaced in this anonymous XSD fragment. The attributes used MUST be restricted to the ones that are shown as valid in the XSD fragment that is contained in this section.

```

<xs:complexType>
  <xs:sequence>
    <xs:element name="ForEachEnumerators"
      type="DTS:ForEachEnumeratorsType"
      minOccurs="0" maxOccurs="0"/>
    <xs:element name="Variables" type="DTS:VariablesType" minOccurs="0"/>
    <xs:element name="LoggingOptions" type="DTS:LoggingOptionsType" />
    <xs:element name="PropertyExpression"
      type="DTS:PropertyExpressionElementType" minOccurs="0"/>
    <xs:element name="Executables" type="DTS:ExecutablesType"
      minOccurs="0" maxOccurs="0"/>
    <xs:element name="PrecedenceConstraints"
      type="DTS:PrecedenceConstraintsType" minOccurs="0"/>
    <xs:element name="ForEachVariableMappings"
      type="DTS:ForEachVariableMappingsType"
      minOccurs="0" maxOccurs="0"/>
    <xs:element name="EventHandlers" type="DTS:EventHandlersType"
      minOccurs="0"/>
    <xs:element name="ObjectData">
      <xs:complexType>
        <xs:choice>
          <xs:element ref="SendMailTask:SendMailTaskData"/>
        </xs:choice>
      </xs:complexType>
    </xs:element>
  </xs:sequence>
  <xs:attribute name="ExecutableType" use="required">
    <xs:simpleType>
      <xs:restriction base="xs:string">
        <xs:enumeration
          value="Microsoft.SqlServer.Dts.Tasks.SendMailTask.SendMailTask,
Microsoft.SqlServer.SqlServer.SendMailTask, Version=11.0.0.0, Culture=neutral,
PublicKeyToken=89845dcd8080cc91"/>
        <xs:enumeration value="STOCK:SendMailTask"/>
      </xs:restriction>
    </xs:simpleType>
  </xs:attribute>
  <xs:attribute name="ThreadHint" use="optional" type="xs:int"/>
  <xs:attributeGroup ref="DTS:BasePropertyAttributeGroup"/>
  <xs:attributeGroup ref="DTS:BaseExecutablePropertyAttributeGroup"/>
  <xs:attributeGroup ref="DTS:AllExecutableAttributeGroup"/>
  <xs:attribute name="ExecutionLocation" type="xs:int" default="0"
    use="optional" form="qualified"/>
  <xs:attribute name="ExecutionAddress" type="xs:string" default=""
    use="optional" form="qualified"/>

```

```

    <xs:attribute name="TaskContact" type="xs:string" default=""
                use="optional" form="qualified"/>
</xs:complexType>

```

2.6.3.16 ExecutableType Instance for Transfer Database Task

An executable is a Transfer Database Task executable if the **ExecutableType** attribute value is "Microsoft.SqlServer.Dts.Tasks.TransferDatabaseTask.TransferDatabaseTask, Microsoft.SqlServer.TransferDatabasesTask, Version=11.0.0.0, Culture=neutral, PublicKeyToken=89845dcd8080cc91" or "STOCK:TransferDatabaseTask".

The Transfer Database Task executable is formally defined to be of type [AnyNonPackageExecutableType](#). However, the following XSD fragment, which is expressed as an anonymous complex type declaration, places further restrictions on the type than the restrictions that are declared in the **AnyNonPackageExecutableType** type declaration. An [Executable](#) element with the **ExecutableType** attribute value equal to "Microsoft.SqlServer.Dts.Tasks.TransferDatabaseTask.TransferDatabaseTask, Microsoft.SqlServer.TransferDatabasesTask, Version=11.0.0.0, Culture=neutral, PublicKeyToken=89845dcd8080cc91" or "STOCK:TransferDatabaseTask" MUST follow the anonymous type declaration that is contained in this section.

Note the following differences between this anonymous complex type declaration and the full definition of the complex type for the **AnyNonPackageExecutableType** type:

- This **Executable** element MUST NOT contain an **Executables** element.
- This **Executable** element MUST NOT contain a **ForEachEnumerators** element.
- This **Executable** element MUST NOT contain a **ForEachVariableMappings** element.
- In the **AnyNonPackageExecutableType** type, the type of the **ObjectData** element is given as [ExecutableObjectDataType](#). The **ExecutableObjectDataType** type definition contains an **xs:choice** XSD Schema element. However, not all of the choices that are allowed in the **xs:choice** XSD Schema element are available for the Transfer Database Task executable. For this **Executable** element, the **ObjectData** element MUST contain the **TransferDatabaseTaskData** element of type [TransferDatabaseTaskDataObjectDataType](#).
- The allowed attributes are a restricted subset of those that are allowed on the type, as specified in the [AnyNonPackageExecutableAttributeGroup](#) attribute group. Hence, the declaration of the attributes is replaced in this anonymous XSD fragment. The attributes used MUST be restricted to the ones that are shown as valid in the XSD fragment that is contained in this section.

```

<xs:complexType>
  <xs:sequence>
    <xs:element name="ForEachEnumerators"
              type="DTS:ForEachEnumeratorsType"
              minOccurs="0" maxOccurs="0"/>
    <xs:element name="Variables" type="DTS:VariablesType" minOccurs="0"/>
    <xs:element name="LoggingOptions" type="DTS:LoggingOptionsType" />
    <xs:element name="PropertyExpression"
              type="DTS:PropertyExpressionElementType" minOccurs="0"/>
    <xs:element name="Executables" type="DTS:ExecutablesType"
              minOccurs="0" maxOccurs="0"/>
    <xs:element name="PrecedenceConstraints"
              type="DTS:PrecedenceConstraintsType" minOccurs="0"/>
  
```

```

<xs:element name="ForEachVariableMappings"
  type="DTS:ForEachVariableMappingsType"
  minOccurs="0" maxOccurs="0"/>
<xs:element name="EventHandlers" type="DTS:EventHandlersType"
  minOccurs="0"/>
<xs:element name="ObjectData">
  <xs:complexType>
    <xs:choice>
      <xs:element name="TransferDatabasesTaskData" form="unqualified"
        type="DTS:TransferDatabasesTaskDataObjectDataType"/>
    </xs:choice>
  </xs:complexType>
</xs:element>
</xs:sequence>
<xs:attribute name="ExecutableType" use="required">
  <xs:simpleType>
    <xs:restriction base="xs:string">
      <xs:enumeration
        value="Microsoft.SqlServer.Dts.Tasks.TransferDatabaseTask.TransferDatabaseTask,
Microsoft.SqlServer.TransferDatabasesTask, Version=11.0.0.0, Culture=neutral,
PublicKeyToken=89845dcd8080cc91"/>
      <xs:enumeration value="STOCK:TransferDatabaseTask"/>
    </xs:restriction>
  </xs:simpleType>
</xs:attribute>
<xs:attribute name="ThreadHint" use="optional" type="xs:int"/>
<xs:attributeGroup ref="DTS:BasePropertyAttributeGroup"/>
<xs:attributeGroup ref="DTS:BaseExecutablePropertyAttributeGroup"/>
<xs:attributeGroup ref="DTS:AllExecutableAttributeGroup"/>
<xs:attribute name="ExecutionLocation" type="xs:int" default="0"
  use="optional" form="qualified"/>
<xs:attribute name="ExecutionAddress" type="xs:string" default=""
  use="optional" form="qualified"/>
<xs:attribute name="TaskContact" type="xs:string" default=""
  use="optional" form="qualified"/>
</xs:complexType>

```

2.6.3.17 ExecutableType Instance for Transfer Error Messages Task

An executable is a Transfer Error Messages Task executable if the **ExecutableType** attribute value is "Microsoft.SqlServer.Dts.Tasks.TransferErrorMessagesTask.TransferErrorMessagesTask, Microsoft.SqlServer.TransferErrorMessagesTask, Version=11.0.0.0, Culture=neutral, PublicKeyToken=89845dcd8080cc91" or "STOCK:TransferErrorMessagesTask".

The Transfer Error Messages Task executable is formally defined to be of type [AnyNonPackageExecutableType](#). However, the following XSD fragment, which is expressed as an anonymous complex type declaration, places further restrictions on the type than the restrictions that are declared in the **AnyNonPackageExecutableType** type declaration. An [Executable](#) element with the **ExecutableType** attribute value equal to "Microsoft.SqlServer.Dts.Tasks.TransferErrorMessagesTask.TransferErrorMessagesTask, Microsoft.SqlServer.TransferErrorMessagesTask, Version=11.0.0.0, Culture=neutral, PublicKeyToken=89845dcd8080cc91" or "STOCK:TransferErrorMessagesTask" MUST follow the anonymous type declaration that is contained in this section.

Note the following differences between this anonymous complex type declaration and the full definition of the complex type for the **AnyNonPackageExecutableType** type:

- This **Executable** element MUST NOT contain an **Executables** element.
- This **Executable** element MUST NOT contain a **ForEachEnumerators** element.
- This **Executable** element MUST NOT contain a **ForEachVariableMappings** element.
- In the **AnyNonPackageExecutableType** type, the type of the **ObjectData** element is given as [ExecutableObjectDataType](#). The **ExecutableObjectDataType** type definition contains an **xs:choice** XSD Schema element. However, not all of the choices that are allowed in the **xs:choice** XSD Schema element are available for the Transfer Error Messages Task executable. For this **Executable** element, the **ObjectData** element MUST contain the **TransferErrorMessagesTaskData** element of type [TransferErrorMessagesTaskDataObjectDataType](#).
- The allowed attributes are a restricted subset of those that are allowed on the type, as specified in the [AnyNonPackageExecutableAttributeGroup](#) attribute group. Hence, the declaration of the attributes is replaced in this anonymous XSD fragment. The attributes used MUST be restricted to the ones that are shown as valid in the XSD fragment that is contained in this section.

```

<xs:complexType>
  <xs:sequence>
    <xs:element name="ForEachEnumerators"
      type="DTS:ForEachEnumeratorsType"
      minOccurs="0" maxOccurs="0"/>
    <xs:element name="Variables" type="DTS:VariablesType" minOccurs="0"/>
    <xs:element name="LoggingOptions" type="DTS:LoggingOptionsType" />
    <xs:element name="PropertyExpression"
      type="DTS:PropertyExpressionElementType" minOccurs="0"/>
    <xs:element name="Executables" type="DTS:ExecutablesType"
      minOccurs="0" maxOccurs="0"/>
    <xs:element name="PrecedenceConstraints"
      type="DTS:PrecedenceConstraintsType" minOccurs="0"/>
    <xs:element name="ForEachVariableMappings"
      type="DTS:ForEachVariableMappingsType"
      minOccurs="0" maxOccurs="0"/>
    <xs:element name="EventHandlers" type="DTS:EventHandlersType"
      minOccurs="0"/>
    <xs:element name="ObjectData">
      <xs:complexType>
        <xs:choice>
          <xs:element name="TransferErrorMessagesTaskData" form="unqualified"
            type="DTS:TransferErrorMessagesTaskDataObjectDataType"/>
        </xs:choice>
      </xs:complexType>
    </xs:element>
  </xs:sequence>
  <xs:attribute name="ExecutableType" use="required">
    <xs:simpleType>
      <xs:restriction base="xs:string">
        <xs:enumeration
value="Microsoft.SqlServer.Dts.Tasks.TransferErrorMessagesTask.TransferErrorMessagesTask,
Microsoft.SqlServer.TransferErrorMessagesTask, Version=11.0.0.0, Culture=neutral,
PublicKeyToken=89845dcd8080cc91"/>
        <xs:enumeration value="STOCK:TransferErrorMessagesTask"/>
      </xs:restriction>
    </xs:simpleType>
  </xs:attribute>

```

```

<xs:attribute name="ThreadHint" use="optional" type="xs:int"/>
<xs:attributeGroup ref="DTS:BasePropertyAttributeGroup"/>
<xs:attributeGroup ref="DTS:BaseExecutablePropertyAttributeGroup"/>
<xs:attributeGroup ref="DTS:AllExecutableAttributeGroup"/>
<xs:attribute name="ExecutionLocation" type="xs:int" default="0"
  use="optional" form="qualified"/>
<xs:attribute name="ExecutionAddress" type="xs:string" default=""
  use="optional" form="qualified"/>
<xs:attribute name="TaskContact" type="xs:string" default=""
  use="optional" form="qualified"/>
</xs:complexType>

```

2.6.3.18 ExecutableType Instance for Transfer Jobs Task

An executable is a Transfer Jobs Task executable if the **ExecutableType** attribute value is "Microsoft.SqlServer.Dts.Tasks.TransferJobsTask.TransferJobsTask, Microsoft.SqlServer.TransferJobsTask, Version=11.0.0.0, Culture=neutral, PublicKeyToken=89845dcd8080cc91" or "STOCK:TransferJobsTask".

The Transfer Jobs Task executable is formally defined to be of type [AnyNonPackageExecutableType](#). However, the following XSD fragment, which is expressed as an anonymous complex type declaration, places further restrictions on the type than the restrictions that are declared in the **AnyNonPackageExecutableType** type declaration. An [Executable](#) element with the **ExecutableType** attribute value equal to "Microsoft.SqlServer.Dts.Tasks.TransferJobsTask.TransferJobsTask, Microsoft.SqlServer.TransferJobsTask, Version=11.0.0.0, Culture=neutral, PublicKeyToken=89845dcd8080cc91" or "STOCK:TransferJobsTask" MUST follow the anonymous type declaration that is contained in this section.

Note the following differences between this anonymous complex type declaration and the full definition of the complex type for the **AnyNonPackageExecutableType** type:

- This **Executable** element MUST NOT contain an **Executables** element.
- This **Executable** element MUST NOT contain a **ForEachEnumerators** element.
- This **Executable** element MUST NOT contain a **ForEachVariableMappings** element.
- In the **AnyNonPackageExecutableType** type, the type of the **ObjectData** element is given as [ExecutableObjectDataType](#). The **ExecutableObjectDataType** type definition contains an **xs:choice** XSD Schema element. However, not all of the choices that are allowed in the **xs:choice** XSD Schema element are available for the Transfer Jobs Task executable. For this **Executable** element, the **ObjectData** element MUST contain the **TransferJobsTaskData** element of type [TransferJobsTaskDataObjectDataType](#).
- The allowed attributes are a restricted subset of those that are allowed on the type, as specified in the [AnyNonPackageExecutableAttributeGroup](#) attribute group. Hence, the declaration of the attributes is replaced in this anonymous XSD fragment. The attributes used MUST be restricted to the ones that are shown as valid in the XSD fragment that is contained in this section.

```

<xs:complexType>
  <xs:sequence>
    <xs:element name="ForEachEnumerators"
      type="DTS:ForEachEnumeratorsType"
      minOccurs="0" maxOccurs="0"/>
  </xs:sequence>
</xs:complexType>

```

```

<xs:element name="Variables" type="DTS:VariablesType" minOccurs="0"/>
<xs:element name="LoggingOptions" type="DTS:LoggingOptionsType" />
<xs:element name="PropertyExpression"
  type="DTS:PropertyExpressionElementType" minOccurs="0"/>
<xs:element name="Executables" type="DTS:ExecutablesType"
  minOccurs="0" maxOccurs="0"/>
<xs:element name="PrecedenceConstraints"
  type="DTS:PrecedenceConstraintsType" minOccurs="0"/>
<xs:element name="ForEachVariableMappings"
  type="DTS:ForEachVariableMappingsType"
  minOccurs="0" maxOccurs="0"/>
<xs:element name="EventHandlers" type="DTS:EventHandlersType"
  minOccurs="0"/>
<xs:element name="ObjectData">
  <xs:complexType>
    <xs:choice>
      <xs:element name="TransferJobsTaskData" form="unqualified"
        type="DTS:TransferJobsTaskDataObjectType"/>
    </xs:choice>
  </xs:complexType>
</xs:element>
</xs:sequence>
<xs:attribute name="ExecutableType" use="required">
  <xs:simpleType>
    <xs:restriction base="xs:string">
      <xs:enumeration
value="Microsoft.SqlServer.Dts.Tasks.TransferJobsTask.TransferJobsTask,
Microsoft.SqlServer.TransferJobsTask, Version=11.0.0.0, Culture=neutral,
PublicKeyToken=89845dcd8080cc91"/>
      <xs:enumeration value="STOCK:TransferJobsTask"/>
    </xs:restriction>
  </xs:simpleType>
</xs:attribute>
<xs:attribute name="ThreadHint" use="optional" type="xs:int"/>
<xs:attributeGroup ref="DTS:BasePropertyAttributeGroup"/>
<xs:attributeGroup ref="DTS:BaseExecutablePropertyAttributeGroup"/>
<xs:attributeGroup ref="DTS:AllExecutableAttributeGroup"/>
<xs:attribute name="ExecutionLocation" type="xs:int" default="0"
  use="optional" form="qualified"/>
<xs:attribute name="ExecutionAddress" type="xs:string" default=""
  use="optional" form="qualified"/>
<xs:attribute name="TaskContact" type="xs:string" default=""
  use="optional" form="qualified"/>
</xs:complexType>

```

2.6.3.19 ExecutableType Instance for Transfer Logins Task

An executable is a Transfer Logins Task executable if the **ExecutableType** attribute value is "Microsoft.SqlServer.Dts.Tasks.TransferLoginsTask.TransferLoginsTask, Microsoft.SqlServer.TransferLoginsTask, Version=11.0.0.0, Culture=neutral, PublicKeyToken=89845dcd8080cc91" or "STOCK:TransferLoginsTask".

The Transfer Logins Task executable is formally defined to be of type [AnyNonPackageExecutableType](#). However, the following XSD fragment, which is expressed as an anonymous complex type declaration, places further restrictions on the type than the restrictions that are declared in the **AnyNonPackageExecutableType** type declaration. An [Executable](#) element with the **ExecutableType** attribute value equal to

"Microsoft.SqlServer.Dts.Tasks.TransferLoginsTask.TransferLoginsTask, Microsoft.SqlServer.TransferLoginsTask, Version=11.0.0.0, Culture=neutral, PublicKeyToken=89845dcd8080cc91" or "STOCK:TransferLoginsTask" MUST follow the anonymous type declaration that is contained in this section.

Note the following differences between this anonymous complex type declaration and the full definition of the complex type for the **AnyNonPackageExecutableType** type:

- This **Executable** element MUST NOT contain an **Executables** element.
- This **Executable** element MUST NOT contain a **ForEachEnumerators** element.
- This **Executable** element MUST NOT contain a **ForEachVariableMappings** element.
- In the **AnyNonPackageExecutableType** type, the type of the **ObjectData** element is given as [ExecutableObjectDataType](#). The **ExecutableObjectDataType** type definition contains an **xs:choice** XSD Schema element. However, not all of the choices that are allowed in the **xs:choice** XSD Schema element are available for the Transfer Logins Task executable. For this **Executable** element, the **ObjectData** element MUST contain the **TransferLoginsTaskData** element of type [TransferLoginsTaskDataObjectDataType](#).
- The allowed attributes are a restricted subset of those that are allowed on the type, as specified in the [AnyNonPackageExecutableAttributeGroup](#) attribute group. Hence, the declaration of the attributes is replaced in this anonymous XSD fragment. The attributes used MUST be restricted to the ones that are shown as valid in the XSD fragment that is contained in this section.

```
<xs:complexType>
  <xs:sequence>
    <xs:element name="ForEachEnumerators"
      type="DTS:ForEachEnumeratorsType"
      minOccurs="0" maxOccurs="0"/>
    <xs:element name="Variables" type="DTS:VariablesType" minOccurs="0"/>
    <xs:element name="LoggingOptions" type="DTS:LoggingOptionsType" />
    <xs:element name="PropertyExpression"
      type="DTS:PropertyExpressionElementType" minOccurs="0"/>
    <xs:element name="Executables" type="DTS:ExecutablesType"
      minOccurs="0" maxOccurs="0"/>
    <xs:element name="PrecedenceConstraints"
      type="DTS:PrecedenceConstraintsType" minOccurs="0"/>
    <xs:element name="ForEachVariableMappings"
      type="DTS:ForEachVariableMappingsType"
      minOccurs="0" maxOccurs="0"/>
    <xs:element name="EventHandlers" type="DTS:EventHandlersType"
      minOccurs="0"/>
    <xs:element name="ObjectData">
      <xs:complexType>
        <xs:choice>
          <xs:element name="TransferLoginsTaskData" form="unqualified"
            type="DTS:TransferLoginsTaskDataObjectDataType"/>
        </xs:choice>
      </xs:complexType>
    </xs:element>
  </xs:sequence>
  <xs:attribute name="ExecutableType" use="required">
    <xs:simpleType>
      <xs:restriction base="xs:string">
```

```

        <xs:enumeration
value="Microsoft.SqlServer.Dts.Tasks.TransferLoginsTask.TransferLoginsTask,
Microsoft.SqlServer.TransferLoginsTask, Version=11.0.0.0, Culture=neutral,
PublicKeyToken=89845dcd8080cc91"/>
        <xs:enumeration value="STOCK:TransferLoginsTask"/>
    </xs:restriction>
</xs:simpleType>
</xs:attribute>
<xs:attribute name="ThreadHint" use="optional" type="xs:int"/>
<xs:attributeGroup ref="DTS:BasePropertyAttributeGroup"/>
<xs:attributeGroup ref="DTS:BaseExecutablePropertyAttributeGroup"/>
<xs:attributeGroup ref="DTS:AllExecutableAttributeGroup"/>
<xs:attribute name="ExecutionLocation" type="xs:int" default="0"
use="optional" form="qualified"/>
<xs:attribute name="ExecutionAddress" type="xs:string" default=""
use="optional" form="qualified"/>
<xs:attribute name="TaskContact" type="xs:string" default=""
use="optional" form="qualified"/>
</xs:complexType>

```

2.6.3.20 ExecutableType Instance for Transfer Stored Procedures Task

An executable is a Transfer Stored Procedures Task executable if the **ExecutableType** attribute value is

"Microsoft.SqlServer.Dts.Tasks.TransferStoredProceduresTask.TransferStoredProceduresTask, Microsoft.SqlServer.TransferStoredProceduresTask, Version=11.0.0.0, Culture=neutral, PublicKeyToken=89845dcd8080cc91" or "STOCK:TransferStoredProceduresTask".

The Transfer Stored Procedures Task executable is formally defined to be of type [AnyNonPackageExecutableType](#). However, the following XSD fragment, which is expressed as an anonymous complex type declaration, places further restrictions on the type than the restrictions that are declared in the **AnyNonPackageExecutableType** type declaration. An [Executable](#) element with the **ExecutableType** attribute value equal to

"Microsoft.SqlServer.Dts.Tasks.TransferStoredProceduresTask.TransferStoredProceduresTask, Microsoft.SqlServer.TransferStoredProceduresTask, Version=11.0.0.0, Culture=neutral, PublicKeyToken=89845dcd8080cc91" or "STOCK:TransferStoredProceduresTask" MUST follow the anonymous type declaration that is contained in this section.

Note the following differences between this anonymous complex type declaration and the full definition of the complex type for the **AnyNonPackageExecutableType** type:

- This **Executable** element MUST NOT contain an **Executables** element.
- This **Executable** element MUST NOT contain a **ForEachEnumerators** element.
- This **Executable** element MUST NOT contain a **ForEachVariableMappings** element.
- In the **AnyNonPackageExecutableType** type, the type of the **ObjectData** element is given as [ExecutableObjectDataType](#). The **ExecutableObjectDataType** type definition contains an **xs:choice** XSD Schema element. However, not all of the choices that are allowed in the **xs:choice** XSD Schema element are available for the Transfer Stored Procedures Task executable. For this **Executable** element, the **ObjectData** element MUST contain the **TransferStoredProceduresTaskData** element of type [TransferStoredProceduresTaskDataObjectDataType](#).

- The allowed attributes are a restricted subset of those that are allowed on the type, as specified in the [AnyNonPackageExecutableAttributeGroup](#) attribute group. Hence, the declaration of the attributes is replaced in this anonymous XSD fragment. The attributes used MUST be restricted to the ones that are shown as valid in the XSD fragment that is contained in this section.

```

<xs:complexType>
  <xs:sequence>
    <xs:element name="ForEachEnumerators"
      type="DTS:ForEachEnumeratorsType"
      minOccurs="0" maxOccurs="0"/>
    <xs:element name="Variables" type="DTS:VariablesType" minOccurs="0"/>
    <xs:element name="LoggingOptions" type="DTS:LoggingOptionsType" />
    <xs:element name="PropertyExpression"
      type="DTS:PropertyExpressionElementType" minOccurs="0"/>
    <xs:element name="Executables" type="DTS:ExecutablesType"
      minOccurs="0" maxOccurs="0"/>
    <xs:element name="PrecedenceConstraints"
      type="DTS:PrecedenceConstraintsType" minOccurs="0"/>
    <xs:element name="ForEachVariableMappings"
      type="DTS:ForEachVariableMappingsType"
      minOccurs="0" maxOccurs="0"/>
    <xs:element name="EventHandlers" type="DTS:EventHandlersType"
      minOccurs="0"/>
    <xs:element name="ObjectData">
      <xs:complexType>
        <xs:choice>
          <xs:element name="TransferStoredProceduresTaskData"
            form="unqualified"
            type="DTS:TransferStoredProceduresTaskDataObjectDataType"/>
        </xs:choice>
      </xs:complexType>
    </xs:element>
  </xs:sequence>
  <xs:attribute name="ExecutableType" use="required">
    <xs:simpleType>
      <xs:restriction base="xs:string">
        <xs:enumeration
value="Microsoft.SqlServer.Dts.Tasks.TransferStoredProceduresTask.TransferStoredProceduresTask, Microsoft.SqlServer.TransferStoredProceduresTask, Version=11.0.0.0, Culture=neutral, PublicKeyToken=89845dcd8080cc91"/>
        <xs:enumeration value="STOCK:TransferStoredProceduresTask"/>
      </xs:restriction>
    </xs:simpleType>
  </xs:attribute>
  <xs:attribute name="ThreadHint" use="optional" type="xs:int"/>
  <xs:attributeGroup ref="DTS:BasePropertyAttributeGroup"/>
  <xs:attributeGroup ref="DTS:BaseExecutablePropertyAttributeGroup"/>
  <xs:attributeGroup ref="DTS:AllExecutableAttributeGroup"/>
  <xs:attribute name="ExecutionLocation" type="xs:int" default="0"
    use="optional" form="qualified"/>
  <xs:attribute name="ExecutionAddress" type="xs:string" default=""
    use="optional" form="qualified"/>
  <xs:attribute name="TaskContact" type="xs:string" default=""
    use="optional" form="qualified"/>
</xs:complexType>

```

2.6.3.21 ExecutableType Instance for Transfer SQL Server Objects Task

An executable is a Transfer SQL Server Objects Task executable if the **ExecutableType** attribute value is

"Microsoft.SqlServer.Dts.Tasks.TransferSqlServerObjectsTask.TransferSqlServerObjectsTask, Microsoft.SqlServer.TransferSqlServerObjectsTask, Version=11.0.0.0, Culture=neutral, PublicKeyToken=89845dcd8080cc91" or "STOCK:TransferObjectsTask".

The Transfer SQL Server Objects Task executable is formally defined to be of type [AnyNonPackageExecutableType](#). However, the following XSD fragment, which is expressed as an anonymous complex type declaration, places further restrictions on the type than the restrictions that are declared in the **AnyNonPackageExecutableType** type declaration. An [Executable](#) element with the **ExecutableType** attribute value equal to

"Microsoft.SqlServer.Dts.Tasks.TransferSqlServerObjectsTask.TransferSqlServerObjectsTask, Microsoft.SqlServer.TransferSqlServerObjectsTask, Version=11.0.0.0, Culture=neutral, PublicKeyToken=89845dcd8080cc91" or "STOCK:TransferObjectsTask" MUST follow the anonymous type declaration that is contained in this section.

Note the following differences between this anonymous complex type declaration and the full definition of the complex type for the **AnyNonPackageExecutableType** type:

- This **Executable** element MUST NOT contain an **Executables** element.
- This **Executable** element MUST NOT contain a **ForEachEnumerators** element.
- This **Executable** element MUST NOT contain a **ForEachVariableMappings** element.
- In the **AnyNonPackageExecutableType** type, the type of the **ObjectData** element is given as [ExecutableObjectDataType](#). The **ExecutableObjectDataType** type definition contains an **xs:choice** XSD Schema element. However, not all of the choices that are allowed in the **xs:choice** XSD Schema element are available for the Transfer SQL Server Objects Task executable. For this **Executable** element, the **ObjectData** element MUST contain the **TransferSqlServerObjectsTaskData** element of type [TransferSqlServerObjectsTaskDataObjectDataType](#).
- The allowed attributes are a restricted subset of those that are allowed on the type, as specified in the [AnyNonPackageExecutableAttributeGroup](#) attribute group. Hence, the declaration of the attributes is replaced in this anonymous XSD fragment. The attributes used MUST be restricted to the ones that are shown as valid in the XSD fragment that is contained in this section.

```
<xs:complexType>
  <xs:sequence>
    <xs:element name="ForEachEnumerators"
      type="DTS:ForEachEnumeratorsType"
      minOccurs="0" maxOccurs="0"/>
    <xs:element name="Variables" type="DTS:VariablesType" minOccurs="0"/>
    <xs:element name="LoggingOptions" type="DTS:LoggingOptionsType" />
    <xs:element name="PropertyExpression"
      type="DTS:PropertyExpressionElementType" minOccurs="0"/>
    <xs:element name="Executables" type="DTS:ExecutablesType"
      minOccurs="0" maxOccurs="0"/>
    <xs:element name="PrecedenceConstraints"
      type="DTS:PrecedenceConstraintsType" minOccurs="0"/>
    <xs:element name="ForEachVariableMappings"
      type="DTS:ForEachVariableMappingsType"
      minOccurs="0" maxOccurs="0"/>
```

```

<xs:element name="EventHandlers" type="DTS:EventHandlersType"
  minOccurs="0"/>
<xs:element name="ObjectData">
  <xs:complexType>
    <xs:choice>
      <xs:element name="TransferSqlServerObjectsTaskData"
        form="unqualified"
        type="DTS:TransferSqlServerObjectsTaskDataObjectDataType"/>
    </xs:choice>
  </xs:complexType>
</xs:element>
</xs:sequence>
<xs:attribute name="ExecutableType" use="required">
  <xs:simpleType>
    <xs:restriction base="xs:string">
      <xs:enumeration
value="Microsoft.SqlServer.Dts.Tasks.TransferSqlServerObjectsTask.TransferSqlServerObjectsTask, Microsoft.SqlServer.TransferSqlServerObjectsTask, Version=11.0.0.0, Culture=neutral, PublicKeyToken=89845dcd8080cc91"/>
      <xs:enumeration value="STOCK:TransferObjectsTask"/>
    </xs:restriction>
  </xs:simpleType>
</xs:attribute>
<xs:attribute name="ThreadHint" use="optional" type="xs:int"/>
<xs:attributeGroup ref="DTS:BasePropertyAttributeGroup"/>
<xs:attributeGroup ref="DTS:BaseExecutablePropertyAttributeGroup"/>
<xs:attributeGroup ref="DTS:AllExecutableAttributeGroup"/>
<xs:attribute name="ExecutionLocation" type="xs:int" default="0"
  use="optional" form="qualified"/>
<xs:attribute name="ExecutionAddress" type="xs:string" default=""
  use="optional" form="qualified"/>
<xs:attribute name="TaskContact" type="xs:string" default=""
  use="optional" form="qualified"/>
</xs:complexType>

```

2.6.3.22 ExecutableType Instance for Web Service Task

An executable is a Web Service Task executable if the **ExecutableType** attribute value is "Microsoft.SqlServer.Dts.Tasks.WebServiceTask.WebServiceTask, Microsoft.SqlServer.WebServiceTask, Version=11.0.0.0, Culture=neutral, PublicKeyToken=89845dcd8080cc91" or "STOCK:WebServiceTask".

The Web Service Task executable is formally defined to be of type [AnyNonPackageExecutableType](#). However, the following XSD fragment, which is expressed as an anonymous complex type declaration, places further restrictions on the type than the restrictions that are declared in the **AnyNonPackageExecutableType** type declaration. An [Executable](#) element with the **ExecutableType** attribute value equal to "Microsoft.SqlServer.Dts.Tasks.WebServiceTask.WebServiceTask, Microsoft.SqlServer.WebServiceTask, Version=11.0.0.0, Culture=neutral, PublicKeyToken=89845dcd8080cc91" or "STOCK:WebServiceTask" MUST follow the anonymous type declaration that is contained in this section.

Note the following differences between this anonymous complex type declaration and the full definition of the complex type for the **AnyNonPackageExecutableType** type:

- This **Executable** element MUST NOT contain an **Executables** element.

- This **Executable** element MUST NOT contain a **ForEachEnumerators** element.
- This **Executable** element MUST NOT contain a **ForEachVariableMappings** element.
- In the **AnyNonPackageExecutableType** type, the type of the **ObjectData** element is given as [ExecutableObjectDataType](#). The **ExecutableObjectDataType** type definition contains an **xs:choice** XSD Schema element. However, not all of the choices that are allowed in the **xs:choice** XSD Schema element are available for the Web Service Task executable. For this **Executable** element, the **ObjectData** element MUST contain the [WebServiceTaskData](#) element that is specified in the **WSTask** namespace.
- The allowed attributes are a restricted subset of those that are allowed on the type, as specified in the [AnyNonPackageExecutableAttributeGroup](#) attribute group. Hence, the declaration of the attributes is replaced in this anonymous XSD fragment. The attributes used MUST be restricted to the ones that are shown as valid in the XSD fragment that is contained in this section.

```

<xs:complexType>
  <xs:sequence>
    <xs:element name="ForEachEnumerators"
      type="DTS:ForEachEnumeratorsType"
      minOccurs="0" maxOccurs="0"/>
    <xs:element name="Variables" type="DTS:VariablesType" minOccurs="0"/>
    <xs:element name="LoggingOptions" type="DTS:LoggingOptionsType" />
    <xs:element name="PropertyExpression"
      type="DTS:PropertyExpressionElementType" minOccurs="0"/>
    <xs:element name="Executables" type="DTS:ExecutablesType"
      minOccurs="0" maxOccurs="0"/>
    <xs:element name="PrecedenceConstraints"
      type="DTS:PrecedenceConstraintsType" minOccurs="0"/>
    <xs:element name="ForEachVariableMappings"
      type="DTS:ForEachVariableMappingsType"
      minOccurs="0" maxOccurs="0"/>
    <xs:element name="EventHandlers" type="DTS:EventHandlersType"
      minOccurs="0"/>
    <xs:element name="ObjectData">
      <xs:complexType>
        <xs:choice>
          <xs:element ref="WSTask:WebServiceTaskData"/>
        </xs:choice>
      </xs:complexType>
    </xs:element>
  </xs:sequence>
  <xs:attribute name="ExecutableType" use="required">
    <xs:simpleType>
      <xs:restriction base="xs:string">
        <xs:enumeration
          value="Microsoft.SqlServer.Dts.Tasks.WebServiceTask.WebServiceTask,
Microsoft.SqlServer.WebServiceTask, Version=11.0.0.0, Culture=neutral,
PublicKeyToken=89845dcd8080cc91"/>
        <xs:enumeration value="STOCK:WebServiceTask"/>
      </xs:restriction>
    </xs:simpleType>
  </xs:attribute>
  <xs:attribute name="ThreadHint" use="optional" type="xs:int"/>
  <xs:attributeGroup ref="DTS:BasePropertyAttributeGroup"/>
  <xs:attributeGroup ref="DTS:BaseExecutablePropertyAttributeGroup"/>
  <xs:attributeGroup ref="DTS:AllExecutableAttributeGroup"/>

```

```

<xs:attribute name="ExecutionLocation" type="xs:int" default="0"
              use="optional" form="qualified"/>
<xs:attribute name="ExecutionAddress" type="xs:string" default=""
              use="optional" form="qualified"/>
<xs:attribute name="TaskContact" type="xs:string" default=""
              use="optional" form="qualified"/>
</xs:complexType>

```

2.6.3.23 ExecutableType Instance for WMI Data Reader Task

An executable is a WMI Data Reader Task executable if the **ExecutableType** attribute value is "Microsoft.SqlServer.Dts.Tasks.WmiDataReaderTask.WmiDataReaderTask, Microsoft.SqlServer.WMIDRTask, Version=11.0.0.0, Culture=neutral, PublicKeyToken=89845dcd8080cc91" or "STOCK:WmiDataReaderTask".

The WMI Data Reader Task executable is formally defined to be of type [AnyNonPackageExecutableType](#). However, the following XSD fragment, which is expressed as an anonymous complex type declaration, places further restrictions on the type than the restrictions that are declared in the **AnyNonPackageExecutableType** type declaration. An [Executable](#) element with the **ExecutableType** attribute value equal to "Microsoft.SqlServer.Dts.Tasks.WmiDataReaderTask.WmiDataReaderTask, Microsoft.SqlServer.WMIDRTask, Version=11.0.0.0, Culture=neutral, PublicKeyToken=89845dcd8080cc91" or "STOCK:WmiDataReaderTask" MUST follow the anonymous type declaration that is contained in this section.

Note the following differences between this anonymous complex type declaration and the full definition of the complex type for the **AnyNonPackageExecutableType** type:

- This **Executable** element MUST NOT contain an **Executables** element.
- This **Executable** element MUST NOT contain a **ForEachEnumerators** element.
- This **Executable** element MUST NOT contain a **ForEachVariableMappings** element.
- In the **AnyNonPackageExecutableType** type, the type of the **ObjectData** element is given as [ExecutableObjectDataType](#). The **ExecutableObjectDataType** type definition contains an **xs:choice** XSD Schema element. However, not all of the choices that are allowed in the **xs:choice** XSD Schema element are available for the WMI Data Reader Task executable. For this **Executable** element, the **ObjectData** element MUST contain the **WMIDRTaskData** element of type [WMIDRTaskDataObjectDataType](#).
- The allowed attributes are a restricted subset of those that are allowed on the type, as specified in the [AnyNonPackageExecutableAttributeGroup](#) attribute group. Hence, the declaration of the attributes is replaced in this anonymous XSD fragment. The attributes used MUST be restricted to the ones that are shown as valid in the XSD fragment that is contained in this section.

```

<xs:complexType>
  <xs:sequence>
    <xs:element name="ForEachEnumerators"
               type="DTS:ForEachEnumeratorsType"
               minOccurs="0" maxOccurs="0"/>
    <xs:element name="Variables" type="DTS:VariablesType" minOccurs="0"/>
    <xs:element name="LoggingOptions" type="DTS:LoggingOptionsType" />
    <xs:element name="PropertyExpression"
               type="DTS:PropertyExpressionElementType" minOccurs="0"/>
  
```

```

<xs:element name="Executables" type="DTS:ExecutablesType"
  minOccurs="0" maxOccurs="0"/>
<xs:element name="PrecedenceConstraints"
  type="DTS:PrecedenceConstraintsType" minOccurs="0"/>
<xs:element name="ForEachVariableMappings"
  type="DTS:ForEachVariableMappingsType"
  minOccurs="0" maxOccurs="0"/>
<xs:element name="EventHandlers" type="DTS:EventHandlersType"
  minOccurs="0"/>
<xs:element name="ObjectData">
  <xs:complexType>
    <xs:choice>
      <xs:element name="WMIDRTaskData"
        type="DTS:WMIDRTaskDataObjectDataType"
        form="unqualified"/>
    </xs:choice>
  </xs:complexType>
</xs:element>
</xs:sequence>
<xs:attribute name="ExecutableType" use="required">
  <xs:simpleType>
    <xs:restriction base="xs:string">
      <xs:enumeration
value="Microsoft.SqlServer.Dts.Tasks.WmiDataReaderTask.WmiDataReaderTask,
Microsoft.SqlServer.WMIDRTask, Version=11.0.0.0, Culture=neutral,
PublicKeyToken=89845dcd8080cc91"/>
      <xs:enumeration value="STOCK:WmiDataReaderTask"/>
    </xs:restriction>
  </xs:simpleType>
</xs:attribute>
<xs:attribute name="ThreadHint" use="optional" type="xs:int"/>
<xs:attributeGroup ref="DTS:BasePropertyAttributeGroup"/>
<xs:attributeGroup ref="DTS:BaseExecutablePropertyAttributeGroup"/>
<xs:attributeGroup ref="DTS:AllExecutableAttributeGroup"/>
<xs:attribute name="ExecutionLocation" type="xs:int" default="0"
  use="optional" form="qualified"/>
<xs:attribute name="ExecutionAddress" type="xs:string" default=""
  use="optional" form="qualified"/>
<xs:attribute name="TaskContact" type="xs:string" default=""
  use="optional" form="qualified"/>
</xs:complexType>

```

2.6.3.24 ExecutableType Instance for WMI Event Watcher Task

An executable is a WMI Event Watcher Task executable if the **ExecutableType** attribute value is "Microsoft.SqlServer.Dts.Tasks.WmiEventWatcherTask.WmiEventWatcherTask, Microsoft.SqlServer.WMIIEWTask, Version=11.0.0.0, Culture=neutral, PublicKeyToken=89845dcd8080cc91" or "STOCK:WmiEventWatcherTask".

The WMI Event Watcher Task executable is formally defined to be of type [AnyNonPackageExecutableType](#). However, the following XSD fragment, which is expressed as an anonymous complex type declaration, places further restrictions on the type than the restrictions that are declared in the **AnyNonPackageExecutableType** type declaration. An [Executable](#) element with the **ExecutableType** attribute value equal to "Microsoft.SqlServer.Dts.Tasks.WmiEventWatcherTask.WmiEventWatcherTask, Microsoft.SqlServer.WMIIEWTask, Version=11.0.0.0, Culture=neutral,

PublicKeyToken=89845dcd8080cc91" or "STOCK:WmiEventWatcherTask" MUST follow the anonymous type declaration that is contained in this section.

Note the following differences between this anonymous complex type declaration and the full definition of the complex type for the **AnyNonPackageExecutableType** type:

- This **Executable** element MUST NOT contain an **Executables** element.
- This **Executable** element MUST NOT contain a **ForEachEnumerators** element.
- This **Executable** element MUST NOT contain a **ForEachVariableMappings** element.
- In the **AnyNonPackageExecutableType** type, the type of the **ObjectData** element is given as [ExecutableObjectDataType](#). The **ExecutableObjectDataType** type definition contains an **xs:choice** XSD Schema element. However, not all of the choices that are allowed in the **xs:choice** XSD Schema element are available for the WMI Event Watcher Task executable. For this **Executable** element, the **ObjectData** element MUST contain the **WMIEWTaskData** element of type [WMIEWTaskDataObjectDataType](#).
- The allowed attributes are a restricted subset of those that are allowed on the type, as specified in the [AnyNonPackageExecutableAttributeGroup](#) attribute group. Hence, the declaration of the attributes is replaced in this anonymous XSD fragment. The attributes used MUST be restricted to the ones that are shown as valid in the XSD fragment that is contained in this section.

```
<xs:complexType>
  <xs:sequence>
    <xs:element name="ForEachEnumerators"
      type="DTS:ForEachEnumeratorsType"
      minOccurs="0" maxOccurs="0"/>
    <xs:element name="Variables" type="DTS:VariablesType" minOccurs="0"/>
    <xs:element name="LoggingOptions" type="DTS:LoggingOptionsType" />
    <xs:element name="PropertyExpression"
      type="DTS:PropertyExpressionElementType" minOccurs="0"/>
    <xs:element name="Executables" type="DTS:ExecutablesType"
      minOccurs="0" maxOccurs="0"/>
    <xs:element name="PrecedenceConstraints"
      type="DTS:PrecedenceConstraintsType" minOccurs="0"/>
    <xs:element name="ForEachVariableMappings"
      type="DTS:ForEachVariableMappingsType"
      minOccurs="0" maxOccurs="0"/>
    <xs:element name="EventHandlers" type="DTS:EventHandlersType"
      minOccurs="0"/>
    <xs:element name="ObjectData">
      <xs:complexType>
        <xs:choice>
          <xs:element
            name="WMIEWTaskData" type="DTS:WMIEWTaskDataObjectDataType"
            form="unqualified"/>
          </xs:choice>
        </xs:complexType>
      </xs:element>
    </xs:sequence>
    <xs:attribute name="ExecutableType" use="required">
      <xs:simpleType>
        <xs:restriction base="xs:string">
          <xs:enumeration
            value="Microsoft.SqlServer.Dts.Tasks.WmiEventWatcherTask.WmiEventWatcherTask,"
```

```

Microsoft.SqlServer.WMIEventTask, Version=11.0.0.0, Culture=neutral,
PublicKeyToken=89845dcd8080cc91"/>
  <xs:enumeration value="STOCK:WmiEventWatcherTask"/>
</xs:restriction>
</xs:simpleType>
</xs:attribute>
<xs:attribute name="ThreadHint" use="optional" type="xs:int"/>
<xs:attributeGroup ref="DTS:BasePropertyAttributeGroup"/>
<xs:attributeGroup ref="DTS:BaseExecutablePropertyAttributeGroup"/>
<xs:attributeGroup ref="DTS:AllExecutableAttributeGroup"/>
<xs:attribute name="ExecutionLocation" type="xs:int" default="0"
  use="optional" form="qualified"/>
<xs:attribute name="ExecutionAddress" type="xs:string" default=""
  use="optional" form="qualified"/>
<xs:attribute name="TaskContact" type="xs:string" default=""
  use="optional" form="qualified"/>
</xs:complexType>

```

2.6.3.25 ExecutableType Instance for XML Task

An executable is an XML Task executable if the **ExecutableType** attribute value is "Microsoft.SqlServer.Dts.Tasks.XMLTask.XMLTask, Microsoft.SqlServer.XMLTask, Version=11.0.0.0, Culture=neutral, PublicKeyToken=89845dcd8080cc91" or "STOCK: XMLTask".

The XML Task executable is formally defined to be of type [AnyNonPackageExecutableType](#). However, the following XSD fragment, which is expressed as an anonymous complex type declaration, places further restrictions on the type than the restrictions that are declared in the **AnyNonPackageExecutableType** type declaration. An [Executable](#) element with the **ExecutableType** attribute value equal to "Microsoft.SqlServer.Dts.Tasks.XMLTask.XMLTask, Microsoft.SqlServer.XMLTask, Version=11.0.0.0, Culture=neutral, PublicKeyToken=89845dcd8080cc91" or "STOCK: XMLTask" MUST follow the anonymous type declaration that is contained in this section.

Note the following differences between this anonymous complex type declaration and the full definition of the complex type for the **AnyNonPackageExecutableType** type:

- This **Executable** element MUST NOT contain an **Executables** element.
- This **Executable** element MUST NOT contain a **ForEachEnumerators** element.
- This **Executable** element MUST NOT contain a **ForEachVariableMappings** element.
- In the **AnyNonPackageExecutableType** type, the type of the **ObjectData** element is given as [ExecutableObjectDataType](#). The **ExecutableObjectDataType** type definition contains an **xs:choice** XSD Schema element. However, not all of the choices that are allowed in the **xs:choice** XSD Schema element are available for the XML Task executable. For this **Executable** element, the **ObjectData** element MUST contain the **XMLTaskData** element of type [XMLTaskDataObjectDataType](#).
- The allowed attributes are a restricted subset of those that are allowed on the type, as specified in the [AnyNonPackageExecutableAttributeGroup](#) attribute group. Hence, the declaration of the attributes is replaced in this anonymous XSD fragment. The attributes used MUST be restricted to the ones that are shown as valid in the XSD fragment that is contained in this section.

```
<xs:complexType>
```



```

<xs:sequence>
  <xs:element name="ForEachEnumerators"
    type="DTS:ForEachEnumeratorsType"
    minOccurs="0" maxOccurs="0"/>
  <xs:element name="Variables" type="DTS:VariablesType" minOccurs="0"/>
  <xs:element name="LoggingOptions" type="DTS:LoggingOptionsType" />
  <xs:element name="PropertyExpression"
    type="DTS:PropertyExpressionElementType" minOccurs="0"/>
  <xs:element name="Executables" type="DTS:ExecutablesType"
    minOccurs="0" maxOccurs="0"/>
  <xs:element name="PrecedenceConstraints"
    type="DTS:PrecedenceConstraintsType" minOccurs="0"/>
  <xs:element name="ForEachVariableMappings"
    type="DTS:ForEachVariableMappingsType"
    minOccurs="0" maxOccurs="0"/>
  <xs:element name="EventHandlers" type="DTS:EventHandlersType"
    minOccurs="0"/>
  <xs:element name="ObjectData">
    <xs:complexType>
      <xs:choice>
        <xs:element name="XMLTaskData"
          type="DTS:XMLTaskDataObjectDataType"
          form="unqualified"/>
      </xs:choice>
    </xs:complexType>
  </xs:element>
</xs:sequence>
<xs:attribute name="ExecutableType" use="required">
  <xs:simpleType>
    <xs:restriction base="xs:string">
      <xs:enumeration
        value="Microsoft.SqlServer.Dts.Tasks.XMLTask.XMLTask, Microsoft.SqlServer.XMLTask,
Version=11.0.0.0, Culture=neutral, PublicKeyToken=89845dcd8080cc91"/>
      <xs:enumeration value="STOCK:XMLTask"/>
    </xs:restriction>
  </xs:simpleType>
</xs:attribute>
<xs:attribute name="ThreadHint" use="optional" type="xs:int"/>
<xs:attributeGroup ref="DTS:BasePropertyAttributeGroup"/>
<xs:attributeGroup ref="DTS:BaseExecutablePropertyAttributeGroup"/>
<xs:attributeGroup ref="DTS:AllExecutableAttributeGroup"/>
<xs:attribute name="ExecutionLocation" type="xs:int" default="0"
  use="optional" form="qualified"/>
<xs:attribute name="ExecutionAddress" type="xs:string" default=""
  use="optional" form="qualified"/>
<xs:attribute name="TaskContact" type="xs:string" default=""
  use="optional" form="qualified"/>
</xs:complexType>

```

2.6.4 Executable Maintenance Tasks

Executable maintenance task types are not a formal type within the XSD. They are a conceptual subdivision of the values for the **ExecutableType** attribute on the [Executable](#) element, as specified by the [AnyNonPackageExecutableType](#) type. The **Executable** elements that are specified in the following subsections MUST NOT contain additional executables nested within an instance of themselves.

2.6.4.1 ExecutableType Instance for Backup Task

An executable is a Backup Task executable if the **ExecutableType** attribute value is "Microsoft.SqlServer.Management.DatabaseMaintenance.DbMaintenanceBackupTask, Microsoft.SqlServer.MaintenancePlanTasks, Version=11.0.0.0, Culture=neutral, PublicKeyToken=89845dcd8080cc91".

The Backup Task executable is formally defined to be of type [AnyNonPackageExecutableType](#). However, the following XSD fragment, which is expressed as an anonymous complex type declaration, places further restrictions on the type than the restrictions that are declared in the **AnyNonPackageExecutableType** type declaration. An [Executable](#) element with the **ExecutableType** attribute value equal to "Microsoft.SqlServer.Management.DatabaseMaintenance.DbMaintenanceBackupTask, Microsoft.SqlServer.MaintenancePlanTasks, Version=11.0.0.0, Culture=neutral, PublicKeyToken=89845dcd8080cc91" MUST follow the anonymous type declaration that is contained in this section.

Note the following differences between this anonymous complex type declaration and the full definition of the complex type for the **AnyNonPackageExecutableType** type:

- This **Executable** element MUST NOT contain an **Executables** element.
- This **Executable** element MUST NOT contain a **ForEachEnumerators** element.
- This **Executable** element MUST NOT contain a **ForEachVariableMappings** element.
- In the **AnyNonPackageExecutableType** type, the type of the **ObjectData** element is given as [ExecutableObjectDataType](#). The **ExecutableObjectDataType** type definition contains an **xs:choice** XSD Schema element. However, all of the choices that are allowed in the **xs:choice** XSD Schema element are not available for the Backup Task executable. For this **Executable** element, the **ObjectData** element MUST contain the [SqlTaskData](#) element that is specified in the [SQLTask](#) namespace. The **SqlTaskData** element declaration in the **SQLTask** namespace MUST be replaced by the declaration and type that is specified in this section. This instance of the **SqlTaskData** element MUST NOT contain elements except for the **SelectedDatabases** element and the **BackupDestinationList** element. This instance of the **SqlTaskData** element MUST NOT contain attributes other than those that are specified in the [SqlTaskBaseAttributeGroup](#) attribute group, the [MaintenanceTaskBaseAttributeGroup](#) attribute group, the [BackupTaskAttributeGroup](#) attribute group, and the **DatabaseSelectionType** attribute.
- The allowed attributes are a restricted subset of those that are allowed on the type, as specified in the [AnyNonPackageExecutableAttributeGroup](#) attribute group. Hence, the declaration of the attributes is replaced in this anonymous XSD fragment. The attributes used MUST be restricted to the ones that are shown as valid in the XSD fragment that is contained in this section.

```
<xs:complexType>
  <xs:sequence>
    <xs:element name="ForEachEnumerators"
      type="DTS:ForEachEnumeratorsType"
      minOccurs="0" maxOccurs="0"/>
    <xs:element name="Variables" type="DTS:VariablesType" minOccurs="0"/>
    <xs:element name="LoggingOptions" type="DTS:LoggingOptionsType" />
    <xs:element name="PropertyExpression"
      type="DTS:PropertyExpressionElementType" minOccurs="0"/>
    <xs:element name="Executables" type="DTS:ExecutablesType"
      minOccurs="0" maxOccurs="0"/>
    <xs:element name="PrecedenceConstraints"
```

```

        type="DTS:PrecedenceConstraintsType" minOccurs="0"/>
<xs:element name="ForEachVariableMappings"
    type="DTS:ForEachVariableMappingsType"
    minOccurs="0" maxOccurs="0"/>
<xs:element name="EventHandlers" type="DTS:EventHandlersType"
    minOccurs="0"/>
<xs:element name="ObjectData">
    <xs:complexType>
        <xs:choice>
            <xs:element ref="SQLTask:SqlTaskData"/>
        </xs:choice>
    </xs:complexType>
</xs:element>
</xs:sequence>
<xs:attribute name="ExecutableType" use="required">
    <xs:simpleType>
        <xs:restriction base="xs:string">
            <xs:enumeration
value="Microsoft.SqlServer.Management.DatabaseMaintenance.DbMaintenanceBackupTask,
Microsoft.SqlServer.MaintenancePlanTasks, Version=11.0.0.0, Culture=neutral,
PublicKeyToken=89845dcd8080cc91"/>
        </xs:restriction>
    </xs:simpleType>
</xs:attribute>
<xs:attribute name="ThreadHint" use="optional" type="xs:int"/>
<xs:attributeGroup ref="DTS:BasePropertyAttributeGroup"/>
<xs:attributeGroup ref="DTS:BaseExecutablePropertyAttributeGroup"/>
<xs:attributeGroup ref="DTS:AllExecutableAttributeGroup"/>
<xs:attribute name="ExecutionLocation" type="xs:int" default="0"
    use="optional" form="qualified"/>
<xs:attribute name="ExecutionAddress" type="xs:string" default=""
    use="optional" form="qualified"/>
<xs:attribute name="TaskContact" type="xs:string" default=""
    use="optional" form="qualified"/>
</xs:complexType>

```

The preceding anonymous complex type definition requires that the declaration for the **SqlTaskData** element and its type, in the **SQLTask** namespace, be changed to the following.

```

<xs:element name="SqlTaskData"
    type="SQLTask:SqlTaskDataElementBackupTaskType"/>
<xs:complexType name="SqlTaskDataElementCheckIntegrityTaskType">
    <xs:sequence>
        <xs:element name="SelectedDatabases"
            type="SQLTask:SelectedDatabasesType"
            minOccurs="0" maxOccurs="unbounded"/>
        <xs:element name="BackupDestinationList"
            type="SQLTask:BackupDestinationListType"
            minOccurs="0" maxOccurs="unbounded"/>
    </xs:sequence>
    <xs:attributeGroup
        ref="SQLTask:SqlTaskBaseAttributeGroup"/>
    <xs:attributeGroup
        ref="SQLTask:MaintenanceTaskBaseAttributeGroup"/>
    <xs:attributeGroup
        ref="SQLTask:CheckIntegrityTaskAttributeGroup"/>
    <xs:attribute name="DatabaseSelectionType"

```

```

        type="SQLTask:SqlTaskDatabaseSelectionTypeEnum"/>
</xs:complexType>

```

2.6.4.2 ExecutableType Instance for Check Integrity Task

An executable is a Check Integrity Task executable if the **ExecutableType** attribute value is "Microsoft.SqlServer.Management.DatabaseMaintenance.DbMaintenanceCheckIntegrityTask, Microsoft.SqlServer.MaintenancePlanTasks, Version=11.0.0.0, Culture=neutral, PublicKeyToken=89845dcd8080cc91".

The Check Integrity Task executable is formally defined to be of type [AnyNonPackageExecutableType](#). However, the following XSD fragment, which is expressed as an anonymous complex type declaration, places further restrictions on the type than the restrictions that are declared in the **AnyNonPackageExecutableType** type declaration. An [Executable](#) element with the **ExecutableType** attribute value equal to "Microsoft.SqlServer.Management.DatabaseMaintenance.DbMaintenanceCheckIntegrityTask, Microsoft.SqlServer.MaintenancePlanTasks, Version=11.0.0.0, Culture=neutral, PublicKeyToken=89845dcd8080cc91" MUST follow the anonymous type declaration that is contained in this section.

Note the following differences between this anonymous complex type declaration and the full definition of the complex type for the **AnyNonPackageExecutableType** type:

- This **Executable** element MUST NOT contain an **Executables** element.
- This **Executable** element MUST NOT contain a **ForEachEnumerators** element.
- This **Executable** element MUST NOT contain a **ForEachVariableMappings** element.
- In the **AnyNonPackageExecutableType** type, the type of the **ObjectData** element is given as [ExecutableObjectDataType](#). The **ExecutableObjectDataType** type definition contains an **xs:choice** XSD Schema element. However, all of the choices that are allowed in the **xs:choice** XSD Schema element are not available for the Check Integrity Task executable. For this **Executable** element, the **ObjectData** element MUST contain the [SqlTaskData](#) element that is specified in the [SQLTask](#) namespace. The **SqlTaskData** element declaration in the **SQLTask** namespace MUST be replaced by the declaration and type that is specified in this section. This instance of the **SqlTaskData** element MUST NOT contain elements except for the **SelectedDatabases** element. This instance of the **SqlTaskData** element MUST NOT contain attributes other than those that are specified in the [SqlTaskBaseAttributeGroup](#) attribute group, the [MaintenanceTaskBaseAttributeGroup](#) attribute group, the [CheckIntegrityTaskAttributeGroup](#) attribute group, and the **DatabaseSelectionType** attribute.
- The allowed attributes are a restricted subset of those that are allowed on the type, as specified in the [AnyNonPackageExecutableAttributeGroup](#) attribute group. Hence, the declaration of the attributes is replaced in this anonymous XSD fragment. The attributes used MUST be restricted to the ones that are shown as valid in the XSD fragment that is contained in this section.

```

<xs:complexType>
  <xs:sequence>
    <xs:element name="ForEachEnumerators"
      type="DTS:ForEachEnumeratorsType"
      minOccurs="0" maxOccurs="0"/>
    <xs:element name="Variables" type="DTS:VariablesType" minOccurs="0"/>
    <xs:element name="LoggingOptions" type="DTS:LoggingOptionsType" />
  
```

```

<xs:element name="PropertyExpression"
  type="DTS:PropertyExpressionElementType" minOccurs="0"/>
<xs:element name="Executables" type="DTS:ExecutablesType"
  minOccurs="0" maxOccurs="0"/>
<xs:element name="PrecedenceConstraints"
  type="DTS:PrecedenceConstraintsType" minOccurs="0"/>
<xs:element name="ForEachVariableMappings"
  type="DTS:ForEachVariableMappingsType"
  minOccurs="0" maxOccurs="0"/>
<xs:element name="EventHandlers" type="DTS:EventHandlersType"
  minOccurs="0"/>
<xs:element name="ObjectData">
  <xs:complexType>
    <xs:choice>
      <xs:element ref="SQLTask:SqlTaskData"/>
    </xs:choice>
  </xs:complexType>
</xs:element>
</xs:sequence>
<xs:attribute name="ExecutableType" use="required">
  <xs:simpleType>
    <xs:restriction base="xs:string">
      <xs:enumeration
value="Microsoft.SqlServer.Management.DatabaseMaintenance.DbMaintenanceCheckIntegrityTask,
Microsoft.SqlServer.MaintenancePlanTasks, Version=11.0.0.0, Culture=neutral,
PublicKeyToken=89845dcd8080cc91"/>
    </xs:restriction>
  </xs:simpleType>
</xs:attribute>
<xs:attribute name="ThreadHint" use="optional" type="xs:int"/>
<xs:attributeGroup ref="DTS:BasePropertyAttributeGroup"/>
<xs:attributeGroup ref="DTS:BaseExecutablePropertyAttributeGroup"/>
<xs:attributeGroup ref="DTS:AllExecutableAttributeGroup"/>
<xs:attribute name="ExecutionLocation" type="xs:int" default="0"
  use="optional" form="qualified"/>
<xs:attribute name="ExecutionAddress" type="xs:string" default=""
  use="optional" form="qualified"/>
<xs:attribute name="TaskContact" type="xs:string" default=""
  use="optional" form="qualified"/>
</xs:complexType>

```

The preceding anonymous complex type definition requires that the declaration for the **SqlTaskData** element and its type, in the **SQLTask** namespace, be changed to the following.

```

<xs:element name="SqlTaskData"
  type="SQLTask:SqlTaskDataElementCheckIntegrityTaskType"/>
<xs:complexType name="SqlTaskDataElementCheckIntegrityTaskType">
  <xs:sequence>
    <xs:element name="SelectedDatabases"
      type="SQLTask:SelectedDatabasesType"
      minOccurs="0" maxOccurs="unbounded"/>
  </xs:sequence>
  <xs:attributeGroup
    ref="SQLTask:SqlTaskBaseAttributeGroup"/>
  <xs:attributeGroup
    ref="SQLTask:MaintenanceTaskBaseAttributeGroup"/>
  <xs:attributeGroup

```

```

        ref="SQLTask:CheckIntegrityTaskAttributeGroup"/>
        <xs:attribute name="DatabaseSelectionType"
                    type="SQLTask:SqlTaskDatabaseSelectionTypeEnum"/>
    </xs:complexType>

```

2.6.4.3 ExecutableType Instance for Execute SQL Agent Job Task

An executable is an Execute SQL Agent Job Task executable if the **ExecutableType** attribute value is "Microsoft.SqlServer.Management.DatabaseMaintenance.DbMaintenanceExecuteAgentJobTask, Microsoft.SqlServer.MaintenancePlanTasks, Version=11.0.0.0, Culture=neutral, PublicKeyToken=89845dcd8080cc91".

The Execute SQL Agent Job Task executable is formally defined to be of type [AnyNonPackageExecutableType](#). However, the following XSD fragment, which is expressed as an anonymous complex type declaration, places further restrictions on the type than the restrictions that are declared in the **AnyNonPackageExecutableType** type declaration. An [Executable](#) element with the **ExecutableType** attribute value equal to "Microsoft.SqlServer.Management.DatabaseMaintenance.DbMaintenanceExecuteAgentJobTask, Microsoft.SqlServer.MaintenancePlanTasks, Version=11.0.0.0, Culture=neutral, PublicKeyToken=89845dcd8080cc91" MUST follow the anonymous type declaration that is contained in this section.

Note the following differences between this anonymous complex type declaration and the full definition of the complex type for the **AnyNonPackageExecutableType** type:

- This **Executable** element MUST NOT contain an **Executables** element.
- This **Executable** element MUST NOT contain a **ForEachEnumerators** element.
- This **Executable** element MUST NOT contain a **ForEachVariableMappings** element.
- In the **AnyNonPackageExecutableType** type, the type of the **ObjectData** element is given as [ExecutableObjectDataType](#). The **ExecutableObjectDataType** type definition contains an **xs:choice** XSD Schema element. However, all of the choices that are allowed in the **xs:choice** XSD Schema element are not available for the Execute SQL Agent Job Task executable. For this **Executable** element, the **ObjectData** element MUST contain the [SqlTaskData](#) element that is specified in the [SQLTask](#) namespace. The **SqlTaskData** element declaration in the **SQLTask** namespace MUST be replaced by the declaration and type that is specified in this section. This instance of the **SqlTaskData** element MUST contain zero elements. This instance of the **SqlTaskData** element MUST NOT contain attributes other than those that are specified in the [SqlTaskBaseAttributeGroup](#) attribute group, the [MaintenanceTaskBaseAttributeGroup](#) attribute group, and the [AgentJobTaskAttributeGroup](#) attribute group.
- The allowed attributes are a restricted subset of those that are allowed on the type, as specified in the [AnyNonPackageExecutableAttributeGroup](#) attribute group. Hence, the declaration of the attributes is replaced in this anonymous XSD fragment. The attributes used MUST be restricted to the ones that are shown as valid in the XSD fragment that is contained in this section.

```

<xs:complexType>
  <xs:sequence>
    <xs:element name="ForEachEnumerators"
                type="DTS:ForEachEnumeratorsType"
                minOccurs="0" maxOccurs="0"/>
    <xs:element name="Variables" type="DTS:VariablesType" minOccurs="0"/>
  </xs:sequence>
</xs:complexType>

```

```

<xs:element name="LoggingOptions" type="DTS:LoggingOptionsType" />
<xs:element name="PropertyExpression"
  type="DTS:PropertyExpressionElementType" minOccurs="0"/>
<xs:element name="Executables" type="DTS:ExecutablesType"
  minOccurs="0" maxOccurs="0"/>
<xs:element name="PrecedenceConstraints"
  type="DTS:PrecedenceConstraintsType" minOccurs="0"/>
<xs:element name="ForEachVariableMappings"
  type="DTS:ForEachVariableMappingsType"
  minOccurs="0" maxOccurs="0"/>
<xs:element name="EventHandlers" type="DTS:EventHandlersType"
  minOccurs="0"/>
<xs:element name="ObjectData">
  <xs:complexType>
    <xs:choice>
      <xs:element ref="SQLTask:SqlTaskData"/>
    </xs:choice>
  </xs:complexType>
</xs:element>
</xs:sequence>
<xs:attribute name="ExecutableType" use="required">
  <xs:simpleType>
    <xs:restriction base="xs:string">
      <xs:enumeration
value="Microsoft.SqlServer.Management.DatabaseMaintenance.DbMaintenanceExecuteAgentJobTask,
Microsoft.SqlServer.MaintenancePlanTasks, Version=11.0.0.0, Culture=neutral,
PublicKeyToken=89845dcd8080cc91"/>
    </xs:restriction>
  </xs:simpleType>
</xs:attribute>
<xs:attribute name="ThreadHint" use="optional" type="xs:int"/>
<xs:attributeGroup ref="DTS:BasePropertyAttributeGroup"/>
<xs:attributeGroup ref="DTS:BaseExecutablePropertyAttributeGroup"/>
<xs:attributeGroup ref="DTS:AllExecutableAttributeGroup"/>
<xs:attribute name="ExecutionLocation" type="xs:int" default="0"
  use="optional" form="qualified"/>
<xs:attribute name="ExecutionAddress" type="xs:string" default=""
  use="optional" form="qualified"/>
<xs:attribute name="TaskContact" type="xs:string" default=""
  use="optional" form="qualified"/>
</xs:complexType>

```

The preceding anonymous complex type definition requires that the declaration for the **SqlTaskData** element and its type, in the **SQLTask** namespace, be changed to the following.

```

<xs:element name="SqlTaskData"
  type="SQLTask:SqlTaskDataElementAgentJobTaskType"/>
<xs:complexType name="SqlTaskDataElementAgentJobTaskType">
  <xs:sequence/>
  <xs:attributeGroup
    ref="SQLTask:SqlTaskBaseAttributeGroup"/>
  <xs:attributeGroup
    ref="SQLTask:MaintenanceTaskBaseAttributeGroup"/>
  <xs:attributeGroup
    ref="SQLTask:AgentJobTaskAttributeGroup"/>
</xs:complexType>

```

2.6.4.4 ExecutableType Instance for History Cleanup Task

An executable is a History Cleanup Task executable if the **ExecutableType** attribute value is "Microsoft.SqlServer.Management.DatabaseMaintenance.DbMaintenanceHistoryCleanupTask, Microsoft.SqlServer.MaintenancePlanTasks, Version=11.0.0.0, Culture=neutral, PublicKeyToken=89845dcd8080cc91".

The History Cleanup Task executable is formally defined to be of type [AnyNonPackageExecutableType](#). However, the following XSD fragment, which is expressed as an anonymous complex type declaration, places further restrictions on the type than the restrictions that are declared in the **AnyNonPackageExecutableType** type declaration. An [Executable](#) element with the **ExecutableType** attribute value equal to "Microsoft.SqlServer.Management.DatabaseMaintenance.DbMaintenanceHistoryCleanupTask, Microsoft.SqlServer.MaintenancePlanTasks, Version=11.0.0.0, Culture=neutral, PublicKeyToken=89845dcd8080cc91" MUST follow the anonymous type declaration that is contained in this section.

Note the following differences between this anonymous complex type declaration and the full definition of the complex type for the **AnyNonPackageExecutableType** type:

- This **Executable** element MUST NOT contain an **Executables** element.
- This **Executable** element MUST NOT contain a **ForEachEnumerators** element.
- This **Executable** element MUST NOT contain a **ForEachVariableMappings** element.
- In the **AnyNonPackageExecutableType** type, the type of the **ObjectData** element is given as [ExecutableObjectDataType](#). The **ExecutableObjectDataType** type definition contains an **xs:choice** XSD Schema element. However, all of the choices that are allowed in the **xs:choice** XSD Schema element are not available for the History Cleanup Task executable. For this **Executable** element, the **ObjectData** element MUST contain the [SqlTaskData](#) element that is specified in the [SQLTask](#) namespace. The **SqlTaskData** element declaration in the **SQLTask** namespace MUST be replaced by the declaration and type that are specified in this section. This instance of the **SqlTaskData** element MUST contain zero elements. This instance of the **SqlTaskData** element MUST NOT contain attributes other than those that are specified in the [SqlTaskBaseAttributeGroup](#) attribute group, the [MaintenanceTaskBaseAttributeGroup](#) attribute group, the [HistoryCleanupTaskAttributeGroup](#) attribute group, the **RemoveOlderThan** attribute, and the **TimeUnitsType** attribute.
- The allowed attributes are a restricted subset of those that are allowed on the type, as specified in the [AnyNonPackageExecutableAttributeGroup](#) attribute group. Hence, the declaration of the attributes is replaced in this anonymous XSD fragment. The attributes used MUST be restricted to the ones that are shown as valid in the XSD fragment that is contained in this section.

```
<xs:complexType>
  <xs:sequence>
    <xs:element name="ForEachEnumerators"
      type="DTS:ForEachEnumeratorsType"
      minOccurs="0" maxOccurs="0"/>
    <xs:element name="Variables" type="DTS:VariablesType" minOccurs="0"/>
    <xs:element name="LoggingOptions" type="DTS:LoggingOptionsType" />
    <xs:element name="PropertyExpression"
      type="DTS:PropertyExpressionElementType" minOccurs="0"/>
    <xs:element name="Executables" type="DTS:ExecutablesType"
      minOccurs="0" maxOccurs="0"/>
    <xs:element name="PrecedenceConstraints"
```



```

        type="DTS:PrecedenceConstraintsType" minOccurs="0"/>
<xs:element name="ForEachVariableMappings"
    type="DTS:ForEachVariableMappingsType"
    minOccurs="0" maxOccurs="0"/>
<xs:element name="EventHandlers" type="DTS:EventHandlersType"
    minOccurs="0"/>
<xs:element name="ObjectData">
    <xs:complexType>
        <xs:choice>
            <xs:element ref="SQLTask:SqlTaskData"/>
        </xs:choice>
    </xs:complexType>
</xs:element>
</xs:sequence>
<xs:attribute name="ExecutableType" use="required">
    <xs:simpleType>
        <xs:restriction base="xs:string">
            <xs:enumeration
value="Microsoft.SqlServer.Management.DatabaseMaintenance.DbMaintenanceHistoryCleanupTask,
Microsoft.SqlServer.MaintenancePlanTasks, Version=11.0.0.0, Culture=neutral,
PublicKeyToken=89845dcd8080cc91"/>
        </xs:restriction>
    </xs:simpleType>
</xs:attribute>
<xs:attribute name="ThreadHint" use="optional" type="xs:int"/>
<xs:attributeGroup ref="DTS:BasePropertyAttributeGroup"/>
<xs:attributeGroup ref="DTS:BaseExecutablePropertyAttributeGroup"/>
<xs:attributeGroup ref="DTS:AllExecutableAttributeGroup"/>
<xs:attribute name="ExecutionLocation" type="xs:int" default="0"
    use="optional" form="qualified"/>
<xs:attribute name="ExecutionAddress" type="xs:string" default=""
    use="optional" form="qualified"/>
<xs:attribute name="TaskContact" type="xs:string" default=""
    use="optional" form="qualified"/>
</xs:complexType>

```

The preceding anonymous complex type definition requires that the declaration for the **SqlTaskData** element and its type, in the **SQLTask** namespace, be changed to the following.

```

<xs:element name="SqlTaskData"
    type="SQLTask:SqlTaskDataElementHistoryCleanupTaskType"/>
<xs:complexType name="SqlTaskDataElementHistoryCleanupTaskType">
    <xs:sequence/>
    <xs:attributeGroup
        ref="SQLTask:SqlTaskBaseAttributeGroup"/>
    <xs:attributeGroup
        ref="SQLTask:MaintenanceTaskBaseAttributeGroup"/>
    <xs:attributeGroup
        ref="SQLTask:HistoryCleanupTaskAttributeGroup"/>
    <xs:attribute name="RemoveOlderThan" type="xs:int"/>
    <xs:attribute name="TimeUnitsType"
        type="SQLTask:SqlTaskTimeUnitsTypeEnum"/>
</xs:complexType>

```

2.6.4.5 ExecutableType Instance for Maintenance File Cleanup Task

An executable is a Maintenance File Cleanup Task executable if the **ExecutableType** attribute value is "Microsoft.SqlServer.Management.DatabaseMaintenance.DbMaintenanceFileCleanupTask, Microsoft.SqlServer.MaintenancePlanTasks, Version=11.0.0.0, Culture=neutral, PublicKeyToken=89845dcd8080cc91".

The Maintenance File Cleanup Task executable is formally defined to be of type [AnyNonPackageExecutableType](#). However, the following XSD fragment, which is expressed as an anonymous complex type declaration, places further restrictions on the type than the restrictions that are declared in the **AnyNonPackageExecutableType** type declaration. An [Executable](#) element with the **ExecutableType** attribute value equal to "Microsoft.SqlServer.Management.DatabaseMaintenance.DbMaintenanceFileCleanupTask, Microsoft.SqlServer.MaintenancePlanTasks, Version=11.0.0.0, Culture=neutral, PublicKeyToken=89845dcd8080cc91" MUST follow the anonymous type declaration that is contained in this section.

Note the following differences between this anonymous complex type declaration and the full definition of the complex type for the **AnyNonPackageExecutableType** type:

- This **Executable** element MUST NOT contain an **Executables** element.
- This **Executable** element MUST NOT contain a **ForEachEnumerators** element.
- This **Executable** element MUST NOT contain a **ForEachVariableMappings** element.
- In the **AnyNonPackageExecutableType** type, the type of the **ObjectData** element is given as [ExecutableObjectDataType](#). The **ExecutableObjectDataType** type definition contains an **xs:choice** XSD Schema element. However, all of the choices that are allowed in the **xs:choice** XSD Schema element are not available for the Maintenance File Cleanup Task executable. For this **Executable** element, the **ObjectData** element MUST contain the [SqlTaskData](#) element that is specified in the [SQLTask](#) namespace. The **SqlTaskData** element declaration in the **SQLTask** namespace MUST be replaced by the declaration and type that is specified in this section. This instance of the **SqlTaskData** element MUST contain zero elements. This instance of the **SqlTaskData** element MUST NOT contain attributes other than those that are specified in the [SqlTaskBaseAttributeGroup](#) attribute group, the [MaintenanceTaskBaseAttributeGroup](#) attribute group, the [MaintenanceFileCleanupTaskAttributeGroup](#) attribute group, the **RemoveOlderThan** attribute, and the **TimeUnitsType** attribute.
- The allowed attributes are a restricted subset of those that are allowed on the type, as specified in the [AnyNonPackageExecutableAttributeGroup](#) attribute group. Hence, the declaration of the attributes is replaced in this anonymous XSD fragment. The attributes used MUST be restricted to the ones that are shown as valid in the XSD fragment that is contained in this section.

```
<xs:complexType>
  <xs:sequence>
    <xs:element name="ForEachEnumerators"
      type="DTS:ForEachEnumeratorsType"
      minOccurs="0" maxOccurs="0"/>
    <xs:element name="Variables" type="DTS:VariablesType" minOccurs="0"/>
    <xs:element name="LoggingOptions" type="DTS:LoggingOptionsType" />
    <xs:element name="PropertyExpression"
      type="DTS:PropertyExpressionElementType" minOccurs="0"/>
    <xs:element name="Executables" type="DTS:ExecutablesType"
      minOccurs="0" maxOccurs="0"/>
    <xs:element name="PrecedenceConstraints"
```

```

        type="DTS:PrecedenceConstraintsType" minOccurs="0"/>
    <xs:element name="ForEachVariableMappings"
        type="DTS:ForEachVariableMappingsType"
        minOccurs="0" maxOccurs="0"/>
    <xs:element name="EventHandlers" type="DTS:EventHandlersType"
        minOccurs="0"/>
    <xs:element name="ObjectData">
        <xs:complexType>
            <xs:choice>
                <xs:element ref="SQLTask:SqlTaskData"/>
            </xs:choice>
        </xs:complexType>
    </xs:element>
</xs:sequence>
<xs:attribute name="ExecutableType" use="required">
    <xs:simpleType>
        <xs:restriction base="xs:string">
            <xs:enumeration
value="Microsoft.SqlServer.Management.DatabaseMaintenance.DbMaintenanceFileCleanupTask,
Microsoft.SqlServer.MaintenancePlanTasks, Version=11.0.0.0, Culture=neutral,
PublicKeyToken=89845dcd8080cc91"/>
        </xs:restriction>
    </xs:simpleType>
</xs:attribute>
<xs:attribute name="ThreadHint" use="optional" type="xs:int"/>
<xs:attributeGroup ref="DTS:BasePropertyAttributeGroup"/>
<xs:attributeGroup ref="DTS:BaseExecutablePropertyAttributeGroup"/>
<xs:attributeGroup ref="DTS:AllExecutableAttributeGroup"/>
<xs:attribute name="ExecutionLocation" type="xs:int" default="0"
    use="optional" form="qualified"/>
<xs:attribute name="ExecutionAddress" type="xs:string" default=""
    use="optional" form="qualified"/>
<xs:attribute name="TaskContact" type="xs:string" default=""
    use="optional" form="qualified"/>
</xs:complexType>

```

The preceding anonymous complex type definition requires that the declaration for the **SqlTaskData** element and its type, in the **SQLTask** namespace, be changed to the following.

```

<xs:element name="SqlTaskData"
    type="SQLTask:SqlTaskDataElementMaintenanceFileCleanupTaskType"/>
<xs:complexType
    name="SqlTaskDataElementMaintenanceFileCleanupTaskType">
    <xs:sequence/>
    <xs:attributeGroup
        ref="SQLTask:SqlTaskBaseAttributeGroup"/>
    <xs:attributeGroup
        ref="SQLTask:MaintenanceTaskBaseAttributeGroup"/>
    <xs:attributeGroup
        ref="SQLTask:MaintenanceFileCleanupTaskAttributeGroup"/>
    <xs:attribute name="RemoveOlderThan" type="xs:int"/>
    <xs:attribute name="TimeUnitsType"
        type="SQLTask:SqlTaskTimeUnitsTypeEnum"/>
</xs:complexType>

```

2.6.4.6 ExecutableType Instance for Notify Operator Task

An executable is a Notify Operator Task executable if the **ExecutableType** attribute value is "Microsoft.SqlServer.Management.DatabaseMaintenance.DbMaintenanceNotifyOperatorTask, Microsoft.SqlServer.MaintenancePlanTasks, Version=11.0.0.0, Culture=neutral, PublicKeyToken=89845dcd8080cc91".

The Notify Operator Task executable is formally defined to be of type [AnyNonPackageExecutableType](#). However, the following XSD fragment, which is expressed as an anonymous complex type declaration, places further restrictions on the type than the restrictions that are declared in the **AnyNonPackageExecutableType** type declaration. An [Executable](#) element with the **ExecutableType** attribute value equal to "Microsoft.SqlServer.Management.DatabaseMaintenance.DbMaintenanceNotifyOperatorTask, Microsoft.SqlServer.MaintenancePlanTasks, Version=11.0.0.0, Culture=neutral, PublicKeyToken=89845dcd8080cc91" MUST follow the anonymous type declaration that is contained in this section.

Note the following differences between this anonymous complex type declaration and the full definition of the complex type for the **AnyNonPackageExecutableType** type:

- This **Executable** element MUST NOT contain an **Executables** element.
- This **Executable** element MUST NOT contain a **ForEachEnumerators** element.
- This **Executable** element MUST NOT contain a **ForEachVariableMappings** element.
- In the **AnyNonPackageExecutableType** type, the type of the **ObjectData** element is given as [ExecutableObjectDataType](#). The **ExecutableObjectDataType** type definition contains an **xs:choice** XSD Schema element. However, all of the choices that are allowed in the **xs:choice** XSD Schema element are not available for the Notify Operator Task executable. For this **Executable** element, the **ObjectData** element MUST contain the [SqlTaskData](#) element that is specified in the [SQLTask](#) namespace. The **SqlTaskData** element declaration in the **SQLTask** namespace MUST be replaced by the declaration and type that is specified in this section. This instance of the **SqlTaskData** element MUST NOT contain elements except for the **NotifyOperator** element. This instance of the **SqlTaskData** element MUST NOT contain attributes other than those that are specified in the [SqlTaskBaseAttributeGroup](#) attribute group, the [MaintenanceTaskBaseAttributeGroup](#) attribute group, and the [NotifyOperatorTaskAttributeGroup](#) attribute group.
- The allowed attributes are a restricted subset of those that are allowed on the type, as specified in the [AnyNonPackageExecutableAttributeGroup](#) attribute group. Hence, the declaration of the attributes is replaced in this anonymous XSD fragment. The attributes used MUST be restricted to the ones that are shown as valid in the XSD fragment that is contained in this section.

```
<xs:complexType>
  <xs:sequence>
    <xs:element name="ForEachEnumerators"
      type="DTS:ForEachEnumeratorsType"
      minOccurs="0" maxOccurs="0"/>
    <xs:element name="Variables" type="DTS:VariablesType" minOccurs="0"/>
    <xs:element name="LoggingOptions" type="DTS:LoggingOptionsType" />
    <xs:element name="PropertyExpression"
      type="DTS:PropertyExpressionElementType" minOccurs="0"/>
    <xs:element name="Executables" type="DTS:ExecutablesType"
      minOccurs="0" maxOccurs="0"/>
    <xs:element name="PrecedenceConstraints"
```

```

        type="DTS:PrecedenceConstraintsType" minOccurs="0"/>
    <xs:element name="ForEachVariableMappings"
        type="DTS:ForEachVariableMappingsType"
        minOccurs="0" maxOccurs="0"/>
    <xs:element name="EventHandlers" type="DTS:EventHandlersType"
        minOccurs="0"/>
    <xs:element name="ObjectData">
        <xs:complexType>
            <xs:choice>
                <xs:element ref="SQLTask:SqlTaskData"/>
            </xs:choice>
        </xs:complexType>
    </xs:element>
</xs:sequence>
<xs:attribute name="ExecutableType" use="required">
    <xs:simpleType>
        <xs:restriction base="xs:string">
            <xs:enumeration
value="Microsoft.SqlServer.Management.DatabaseMaintenance.DbMaintenanceNotifyOperatorTask,
Microsoft.SqlServer.MaintenancePlanTasks, Version=11.0.0.0, Culture=neutral,
PublicKeyToken=89845dcd8080cc91"/>
        </xs:restriction>
    </xs:simpleType>
</xs:attribute>
<xs:attribute name="ThreadHint" use="optional" type="xs:int"/>
<xs:attributeGroup ref="DTS:BasePropertyAttributeGroup"/>
<xs:attributeGroup ref="DTS:BaseExecutablePropertyAttributeGroup"/>
<xs:attributeGroup ref="DTS:AllExecutableAttributeGroup"/>
<xs:attribute name="ExecutionLocation" type="xs:int" default="0"
    use="optional" form="qualified"/>
<xs:attribute name="ExecutionAddress" type="xs:string" default=""
    use="optional" form="qualified"/>
<xs:attribute name="TaskContact" type="xs:string" default=""
    use="optional" form="qualified"/>
</xs:complexType>

```

The preceding anonymous complex type definition requires that the declaration for the **SqlTaskData** element and its type, in the **SQLTask** namespace, be changed to the following.

```

<xs:element name="SqlTaskData"
    type="SQLTask:SqlTaskDataElementNotifyOperatorTaskType"/>
<xs:complexType name="SqlTaskDataElementNotifyOperatorTaskType">
    <xs:sequence>
        <xs:element name="OperatorNotifyList"
            type="SQLTask:OperatorNotifyListType"
            minOccurs="0" maxOccurs="unbounded"/>
    </xs:sequence>
    <xs:attributeGroup
        ref="SQLTask:SqlTaskBaseAttributeGroup"/>
    <xs:attributeGroup
        ref="SQLTask:MaintenanceTaskBaseAttributeGroup"/>
    <xs:attributeGroup
        ref="SQLTask:NotifyOperatorTaskAttributeGroup"/>
</xs:complexType>

```

2.6.4.7 ExecutableType Instance for Rebuild Index Task

An executable is a Rebuild Index Task executable if the **ExecutableType** attribute value is "Microsoft.SqlServer.Management.DatabaseMaintenance.DbMaintenanceReindexTask, Microsoft.SqlServer.MaintenancePlanTasks, Version=11.0.0.0, Culture=neutral, PublicKeyToken=89845dcd8080cc91".

The Rebuild Index Task executable is formally defined to be of type [AnyNonPackageExecutableType](#). However, the following XSD fragment, which is expressed as an anonymous complex type declaration, places further restrictions on the type than the restrictions that are declared in the **AnyNonPackageExecutableType** type declaration. An [Executable](#) element with the **ExecutableType** attribute value equal to "Microsoft.SqlServer.Management.DatabaseMaintenance.DbMaintenanceReindexTask, Microsoft.SqlServer.MaintenancePlanTasks, Version=11.0.0.0, Culture=neutral, PublicKeyToken=89845dcd8080cc91" MUST follow the anonymous type declaration that is contained in this section.

Note the following differences between this anonymous complex type declaration and the full definition of the complex type for the **AnyNonPackageExecutableType** type:

- This **Executable** element MUST NOT contain an **Executables** element.
- This **Executable** element MUST NOT contain a **ForEachEnumerators** element.
- This **Executable** element MUST NOT contain a **ForEachVariableMappings** element.
- In the **AnyNonPackageExecutableType** type, the type of the **ObjectData** element is given as [ExecutableObjectDataType](#). The **ExecutableObjectDataType** type definition contains an **xs:choice** XSD Schema element. However, all of the choices that are allowed in the **xs:choice** XSD Schema element are not available for the Rebuild Index Task executable. For this **Executable** element, the **ObjectData** element MUST contain the [SqlTaskData](#) element that is specified in the [SQLTask](#) namespace. The **SqlTaskData** element declaration in the **SQLTask** namespace MUST be replaced by the declaration and type that is specified in this section. This instance of the **SqlTaskData** element MUST NOT contain elements except the **SelectedDatabases** element. This instance of the **SqlTaskData** element MUST NOT contain attributes other than those that are specified in the [SqlTaskBaseAttributeGroup](#) attribute group, the [MaintenanceTaskBaseAttributeGroup](#) attribute group, the [RebuildIndexTaskAttributeGroup](#) attribute group, and the **DatabaseSelectionType** attribute.
- The allowed attributes are a restricted subset of those that are allowed on the type, as specified in the [AnyNonPackageExecutableAttributeGroup](#) attribute group. Hence, the declaration of the attributes is replaced in this anonymous XSD fragment. The attributes used MUST be restricted to the ones that are shown as valid in the XSD fragment that is contained in this section.

```
<xs:complexType>
  <xs:sequence>
    <xs:element name="ForEachEnumerators"
      type="DTS:ForEachEnumeratorsType"
      minOccurs="0" maxOccurs="0"/>
    <xs:element name="Variables" type="DTS:VariablesType" minOccurs="0"/>
    <xs:element name="LoggingOptions" type="DTS:LoggingOptionsType" />
    <xs:element name="PropertyExpression"
      type="DTS:PropertyExpressionElementType" minOccurs="0"/>
    <xs:element name="Executables" type="DTS:ExecutablesType"
      minOccurs="0" maxOccurs="0"/>
    <xs:element name="PrecedenceConstraints"
```

```

        type="DTS:PrecedenceConstraintsType" minOccurs="0"/>
<xs:element name="ForEachVariableMappings"
    type="DTS:ForEachVariableMappingsType"
    minOccurs="0" maxOccurs="0"/>
<xs:element name="EventHandlers" type="DTS:EventHandlersType"
    minOccurs="0"/>
<xs:element name="ObjectData">
    <xs:complexType>
        <xs:choice>
            <xs:element ref="SQLTask:SqlTaskData"/>
        </xs:choice>
    </xs:complexType>
</xs:element>
</xs:sequence>
<xs:attribute name="ExecutableType" use="required">
    <xs:simpleType>
        <xs:restriction base="xs:string">
            <xs:enumeration
value="Microsoft.SqlServer.Management.DatabaseMaintenance.DbMaintenanceReindexTask,
Microsoft.SqlServer.MaintenancePlanTasks, Version=11.0.0.0, Culture=neutral,
PublicKeyToken=89845dcd8080cc91"/>
        </xs:restriction>
    </xs:simpleType>
</xs:attribute>
<xs:attribute name="ThreadHint" use="optional" type="xs:int"/>
<xs:attributeGroup ref="DTS:BasePropertyAttributeGroup"/>
<xs:attributeGroup ref="DTS:BaseExecutablePropertyAttributeGroup"/>
<xs:attributeGroup ref="DTS:AllExecutableAttributeGroup"/>
<xs:attribute name="ExecutionLocation" type="xs:int" default="0"
    use="optional" form="qualified"/>
<xs:attribute name="ExecutionAddress" type="xs:string" default=""
    use="optional" form="qualified"/>
<xs:attribute name="TaskContact" type="xs:string" default=""
    use="optional" form="qualified"/>
</xs:complexType>

```

The preceding anonymous complex type definition requires that the declaration for the **SqlTaskData** element and its type, in the **SQLTask** namespace, be changed to the following.

```

<xs:element name="SqlTaskData"
    type="SQLTask:SqlTaskDataElementRebuildIndexTaskType"/>
<xs:complexType name="SqlTaskDataElementRebuildIndexTaskType">
    <xs:sequence>
        <xs:element name="SelectedDatabases"
            type="SQLTask:SelectedDatabasesType"
            minOccurs="0" maxOccurs="unbounded"/>
    </xs:sequence>
    <xs:attributeGroup
        ref="SQLTask:SqlTaskBaseAttributeGroup"/>
    <xs:attributeGroup
        ref="SQLTask:MaintenanceTaskBaseAttributeGroup"/>
    <xs:attributeGroup
        ref="SQLTask:RebuildIndexTaskAttributeGroup"/>
    <xs:attribute name="DatabaseSelectionType"
        type="SQLTask:SqlTaskDatabaseSelectionTypeEnum"/>
</xs:complexType>

```

2.6.4.8 ExecutableType Instance for Reorganize Index Task

An executable is a Reorganize Index Task executable if the **ExecutableType** attribute value is "Microsoft.SqlServer.Management.DatabaseMaintenance.DbMaintenanceDefragmentIndexTask, Microsoft.SqlServer.MaintenancePlanTasks, Version=11.0.0.0, Culture=neutral, PublicKeyToken=89845dcd8080cc91".

The Reorganize Index Task executable is formally defined to be of type [AnyNonPackageExecutableType](#). However, the following XSD fragment, which is expressed as an anonymous complex type declaration, places further restrictions on the type than the restrictions that are declared in the **AnyNonPackageExecutableType** type declaration. An [Executable](#) element with the **ExecutableType** attribute value equal to "Microsoft.SqlServer.Management.DatabaseMaintenance.DbMaintenanceDefragmentIndexTask, Microsoft.SqlServer.MaintenancePlanTasks, Version=11.0.0.0, Culture=neutral, PublicKeyToken=89845dcd8080cc91" MUST follow the anonymous type declaration that is contained in this section.

Note the following differences between this anonymous complex type declaration and the full definition of the complex type for the **AnyNonPackageExecutableType** type:

- This **Executable** element MUST NOT contain an **Executables** element.
- This **Executable** element MUST NOT contain a **ForEachEnumerators** element.
- This **Executable** element MUST NOT contain a **ForEachVariableMappings** element.
- In the **AnyNonPackageExecutableType** type, the type of the **ObjectData** element is given as [ExecutableObjectDataType](#). The **ExecutableObjectDataType** type definition contains an **xs:choice** XSD Schema element. However, all of the choices that are allowed in the **xs:choice** XSD Schema element are not available for the Reorganize Index Task executable. For this **Executable** element, the **ObjectData** element MUST contain the [SqlTaskData](#) element that is specified in the [SQLTask](#) namespace. The **SqlTaskData** element declaration in the **SQLTask** namespace MUST be replaced by the declaration and type that is specified in this section. This instance of the **SqlTaskData** element MUST NOT contain elements except for the **SelectedDatabases** element. This instance of the **SqlTaskData** element MUST NOT contain attributes other than those that are in the [SqlTaskBaseAttributeGroup](#) attribute group, the [MaintenanceTaskBaseAttributeGroup](#) attribute group, the **ReorganizeIndexTaskAttributeGroup** attribute group, and the **DatabaseSelectionType** attribute.
- The allowed attributes are a restricted subset of those that are allowed on the type, as specified in the [AnyNonPackageExecutableAttributeGroup](#) attribute group. Hence, the declaration of the attributes is replaced in this anonymous XSD fragment. The attributes used MUST be restricted to the ones that are shown as valid in the XSD fragment that is contained in this section.

```
<xs:complexType>
  <xs:sequence>
    <xs:element name="ForEachEnumerators"
      type="DTS:ForEachEnumeratorsType"
      minOccurs="0" maxOccurs="0"/>
    <xs:element name="Variables" type="DTS:VariablesType" minOccurs="0"/>
    <xs:element name="LoggingOptions" type="DTS:LoggingOptionsType" />
    <xs:element name="PropertyExpression"
      type="DTS:PropertyExpressionElementType" minOccurs="0"/>
    <xs:element name="Executables" type="DTS:ExecutablesType"
```



```

        minOccurs="0" maxOccurs="0"/>
<xs:element name="PrecedenceConstraints"
  type="DTS:PrecedenceConstraintsType" minOccurs="0"/>
<xs:element name="ForEachVariableMappings"
  type="DTS:ForEachVariableMappingsType"
  minOccurs="0" maxOccurs="0"/>
<xs:element name="EventHandlers" type="DTS:EventHandlersType"
  minOccurs="0"/>
<xs:element name="ObjectData">
  <xs:complexType>
    <xs:choice>
      <xs:element ref="SQLTask:SqlTaskData"/>
    </xs:choice>
  </xs:complexType>
</xs:element>
</xs:sequence>
<xs:attribute name="ExecutableType" use="required">
  <xs:simpleType>
    <xs:restriction base="xs:string">
      <xs:enumeration
value="Microsoft.SqlServer.Management.DatabaseMaintenance.DbMaintenanceDefragmentIndexTask,
Microsoft.SqlServer.Management.MaintenancePlanTasks, Version=11.0.0.0, Culture=neutral,
PublicKeyToken=89845dcd8080cc91"/>
    </xs:restriction>
  </xs:simpleType>
</xs:attribute>
<xs:attribute name="ThreadHint" use="optional" type="xs:int"/>
<xs:attributeGroup ref="DTS:BasePropertyAttributeGroup"/>
<xs:attributeGroup ref="DTS:BaseExecutablePropertyAttributeGroup"/>
<xs:attributeGroup ref="DTS:AllExecutableAttributeGroup"/>
<xs:attribute name="ExecutionLocation" type="xs:int" default="0"
  use="optional" form="qualified"/>
<xs:attribute name="ExecutionAddress" type="xs:string" default=""
  use="optional" form="qualified"/>
<xs:attribute name="TaskContact" type="xs:string" default=""
  use="optional" form="qualified"/>
</xs:complexType>

```

The preceding anonymous complex type definition requires that the declaration for the **SqlTaskData** element and its type, in the **SQLTask** namespace, be changed to the following.

```

<xs:element name="SqlTaskData"
  type="SQLTask:SqlTaskDataElementReorganizeIndexTaskType"/>
<xs:complexType
  name="SqlTaskDataElementReorganizeIndexTaskType">
  <xs:sequence>
    <xs:element name="SelectedDatabases"
      type="SQLTask:SelectedDatabasesType"
      minOccurs="0" maxOccurs="unbounded"/>
  </xs:sequence>
  <xs:attributeGroup
    ref="SQLTask:SqlTaskBaseAttributeGroup"/>
  <xs:attributeGroup
    ref="SQLTask:MaintenanceTaskBaseAttributeGroup"/>
  <xs:attributeGroup
    ref="SQLTask:ReorganizeIndexTaskAttributeGroup"/>
  <xs:attribute name="DatabaseSelectionType"

```

```

        type="SQLTask:SqlTaskDatabaseSelectionTypeEnum"/>
</xs:complexType>

```

2.6.4.9 ExecutableType Instance for Shrink Database Task

An executable is a Shrink Database Task executable if the **ExecutableType** attribute value is "Microsoft.SqlServer.Management.DatabaseMaintenance.DbMaintenanceShrinkTask, Microsoft.SqlServer.MaintenancePlanTasks, Version=11.0.0.0, Culture=neutral, PublicKeyToken=89845dcd8080cc91".

The Shrink Database Task executable is formally defined to be of type [AnyNonPackageExecutableType](#). However, the following XSD fragment, which is expressed as an anonymous complex type declaration, places further restrictions on the type than the restrictions that are declared in the **AnyNonPackageExecutableType** type declaration. An [Executable](#) element with the **ExecutableType** attribute value equal to "Microsoft.SqlServer.Management.DatabaseMaintenance.DbMaintenanceShrinkTask, Microsoft.SqlServer.MaintenancePlanTasks, Version=11.0.0.0, Culture=neutral, PublicKeyToken=89845dcd8080cc91" MUST follow the anonymous type declaration that is contained in this section.

Note the following differences between this anonymous complex type declaration and the full definition of the complex type for the **AnyNonPackageExecutableType** type:

- This **Executable** element MUST NOT contain an **Executables** element.
- This **Executable** element MUST NOT contain a **ForEachEnumerators** element.
- This **Executable** element MUST NOT contain a **ForEachVariableMappings** element.
- In the **AnyNonPackageExecutableType** type, the type of the **ObjectData** element is given as [ExecutableObjectDataType](#). The **ExecutableObjectDataType** type definition contains an **xs:choice** XSD Schema element. However, all of the choices that are allowed in the **xs:choice** XSD Schema element are not available for the Shrink Database Task executable. For this **Executable** element, the **ObjectData** element MUST contain the [SqlTaskData](#) element that is specified in the [SQLTask](#) namespace. The **SqlTaskData** element declaration in the **SQLTask** namespace MUST be replaced by the declaration and type that is specified in this section. This instance of the **SqlTaskData** element MUST NOT contain elements except for the **SelectedDatabases** element. This instance of the **SqlTaskData** element MUST NOT contain attributes other than those that are specified in the [SqlTaskBaseAttributeGroup](#) attribute group, the [MaintenanceTaskBaseAttributeGroup](#) attribute group, the [ShrinkDBTaskAttributeGroup](#) attribute group, and the **DatabaseSelectionType** attribute.
- The allowed attributes are a restricted subset of those that are allowed on the type, as specified in the [AnyNonPackageExecutableAttributeGroup](#) attribute group. Hence, the declaration of the attributes is replaced in this anonymous XSD fragment. The attributes used MUST be restricted to the ones that are shown as valid in the XSD fragment that is contained in this section.

```

<xs:complexType>
  <xs:sequence>
    <xs:element name="ForEachEnumerators"
      type="DTS:ForEachEnumeratorsType"
      minOccurs="0" maxOccurs="0"/>
    <xs:element name="Variables" type="DTS:VariablesType" minOccurs="0"/>
    <xs:element name="LoggingOptions" type="DTS:LoggingOptionsType" />
  
```

```

<xs:element name="PropertyExpression"
  type="DTS:PropertyExpressionElementType" minOccurs="0"/>
<xs:element name="Executables" type="DTS:ExecutablesType"
  minOccurs="0" maxOccurs="0"/>
<xs:element name="PrecedenceConstraints"
  type="DTS:PrecedenceConstraintsType" minOccurs="0"/>
<xs:element name="ForEachVariableMappings"
  type="DTS:ForEachVariableMappingsType"
  minOccurs="0" maxOccurs="0"/>
<xs:element name="EventHandlers" type="DTS:EventHandlersType"
  minOccurs="0"/>
<xs:element name="ObjectData">
  <xs:complexType>
    <xs:choice>
      <xs:element ref="SQLTask:SqlTaskData"/>
    </xs:choice>
  </xs:complexType>
</xs:element>
</xs:sequence>
<xs:attribute name="ExecutableType" use="required">
  <xs:simpleType>
    <xs:restriction base="xs:string">
      <xs:enumeration
value="Microsoft.SqlServer.Management.DatabaseMaintenance.DbMaintenanceShrinkTask,
Microsoft.SqlServer.MaintenancePlanTasks, Version=11.0.0.0, Culture=neutral,
PublicKeyToken=89845dcd8080cc91"/>
    </xs:restriction>
  </xs:simpleType>
</xs:attribute>
<xs:attribute name="ThreadHint" use="optional" type="xs:int"/>
<xs:attributeGroup ref="DTS:BasePropertyAttributeGroup"/>
<xs:attributeGroup ref="DTS:BaseExecutablePropertyAttributeGroup"/>
<xs:attributeGroup ref="DTS:AllExecutableAttributeGroup"/>
<xs:attribute name="ExecutionLocation" type="xs:int" default="0"
  use="optional" form="qualified"/>
<xs:attribute name="ExecutionAddress" type="xs:string" default=""
  use="optional" form="qualified"/>
<xs:attribute name="TaskContact" type="xs:string" default=""
  use="optional" form="qualified"/>
</xs:complexType>

```

The preceding anonymous complex type definition requires that the declaration for the **SqlTaskData** element and its type, in the **SQLTask** namespace, be changed to the following.

```

<xs:element name="SqlTaskData"
  type="SQLTask:SqlTaskDataElementShrinkDatabaseTaskType"/>
<xs:complexType
  name="SqlTaskDataElementShrinkDatabaseTaskType">
  <xs:sequence>
    <xs:element name="SelectedDatabases"
      type="SQLTask:SelectedDatabasesType"
      minOccurs="0" maxOccurs="unbounded"/>
  </xs:sequence>
  <xs:attributeGroup
    ref="SQLTask:SqlTaskBaseAttributeGroup"/>
  <xs:attributeGroup
    ref="SQLTask:MaintenanceTaskBaseAttributeGroup"/>

```

```

<xs:attributeGroup
  ref="SQLTask:ShrinkDBTaskAttributeGroup"/>
<xs:attribute name="DatabaseSelectionType"
  type="SQLTask:SqlTaskDatabaseSelectionTypeEnum"/>
</xs:complexType>

```

2.6.4.10 ExecutableType Instance for Update Statistics Task

An executable is an Update Statistics Task executable if the **ExecutableType** attribute value is "Microsoft.SqlServer.Management.DatabaseMaintenance.DbMaintenanceUpdateStatisticsTask, Microsoft.SqlServer.MaintenancePlanTasks, Version=11.0.0.0, Culture=neutral, PublicKeyToken=89845dcd8080cc91".

The Update Statistics Task executable is formally defined to be of type [AnyNonPackageExecutableType](#). However, the following XSD fragment, which is expressed as an anonymous complex type declaration, places further restrictions on the type than the restrictions that are declared in the **AnyNonPackageExecutableType** type declaration. An [Executable](#) element with the **ExecutableType** attribute value equal to "Microsoft.SqlServer.Management.DatabaseMaintenance.DbMaintenanceUpdateStatisticsTask, Microsoft.SqlServer.MaintenancePlanTasks, Version=11.0.0.0, Culture=neutral, PublicKeyToken=89845dcd8080cc91" MUST follow the anonymous type declaration that is contained in this section.

Note the following differences between this anonymous complex type declaration and the full definition of the complex type for the **AnyNonPackageExecutableType** type:

- This **Executable** element MUST NOT contain an **Executables** element.
- This **Executable** element MUST NOT contain a **ForEachEnumerators** element.
- This **Executable** element MUST NOT contain a **ForEachVariableMappings** element.
- In the **AnyNonPackageExecutableType** type, the type of the **ObjectData** element is given as [ExecutableObjectDataType](#). The **ExecutableObjectDataType** type definition contains an **xs:choice** XSD Schema element. However, all of the choices that are allowed in the **xs:choice** XSD Schema element are not available for the Update Statistics Task executable. For this **Executable** element, the **ObjectData** element MUST contain the [SqlTaskData](#) element that is specified in the [SQLTask](#) namespace. The **SqlTaskData** element declaration in the **SQLTask** namespace MUST be replaced by the declaration and type that is specified in this section. This instance of the **SqlTaskData** element MUST NOT contain elements except for the **SelectedDatabases** element. This instance of the **SqlTaskData** element MUST NOT contain attributes other than those that are specified in the [SqlTaskBaseAttributeGroup](#) attribute group, the [MaintenanceTaskBaseAttributeGroup](#) attribute group, the [UpdateStatisticsTaskAttributeGroup](#) attribute group, and the **DatabaseSelectionType** attribute.
- The allowed attributes are a restricted subset of those that are allowed on the type, as specified in the [AnyNonPackageExecutableAttributeGroup](#) attribute group. Hence, the declaration of the attributes is replaced in this anonymous XSD fragment. The attributes used MUST be restricted to the ones that are shown as valid in the XSD fragment that is contained in this section.

```

<xs:complexType>
  <xs:sequence>
    <xs:element name="ForEachEnumerators"
      type="DTS:ForEachEnumeratorsType"

```

```

        minOccurs="0" maxOccurs="0"/>
<xs:element name="Variables" type="DTS:VariablesType" minOccurs="0"/>
<xs:element name="LoggingOptions" type="DTS:LoggingOptionsType" />
<xs:element name="PropertyExpression"
    type="DTS:PropertyExpressionElementType" minOccurs="0"/>
<xs:element name="Executables" type="DTS:ExecutablesType"
    minOccurs="0" maxOccurs="0"/>
<xs:element name="PrecedenceConstraints"
    type="DTS:PrecedenceConstraintsType" minOccurs="0"/>
<xs:element name="ForEachVariableMappings"
    type="DTS:ForEachVariableMappingsType"
    minOccurs="0" maxOccurs="0"/>
<xs:element name="EventHandlers" type="DTS:EventHandlersType"
    minOccurs="0"/>
<xs:element name="ObjectData">
    <xs:complexType>
        <xs:choice>
            <xs:element ref="SQLTask:SqlTaskData"/>
        </xs:choice>
    </xs:complexType>
</xs:element>
</xs:sequence>
<xs:attribute name="ExecutableType" use="required">
    <xs:simpleType>
        <xs:restriction base="xs:string">
            <xs:enumeration
value="Microsoft.SqlServer.Management.DatabaseMaintenance.DbMaintenanceUpdateStatisticsTask,
Microsoft.SqlServer.MaintenancePlanTasks, Version=11.0.0.0, Culture=neutral,
PublicKeyToken=89845dcd8080cc91"/>
        </xs:restriction>
    </xs:simpleType>
</xs:attribute>
<xs:attribute name="ThreadHint" use="optional" type="xs:int"/>
<xs:attributeGroup ref="DTS:BasePropertyAttributeGroup"/>
<xs:attributeGroup ref="DTS:BaseExecutablePropertyAttributeGroup"/>
<xs:attributeGroup ref="DTS:AllExecutableAttributeGroup"/>
<xs:attribute name="ExecutionLocation" type="xs:int" default="0"
    use="optional" form="qualified"/>
<xs:attribute name="ExecutionAddress" type="xs:string" default=""
    use="optional" form="qualified"/>
<xs:attribute name="TaskContact" type="xs:string" default=""
    use="optional" form="qualified"/>
</xs:complexType>

```

The preceding anonymous complex type definition requires that the declaration for the **SqlTaskData** element and its type, in the **SQLTask** namespace, be changed to the following.

```

<xs:element name="SqlTaskData"
    type="SQLTask:SqlTaskDataElementUpdateStatisticsTaskType"/>
<xs:complexType
    name="SqlTaskDataElementUpdateStatisticsTaskType">
    <xs:sequence>
        <xs:element name="SelectedDatabases"
            type="SQLTask:SelectedDatabasesType"
            minOccurs="0" maxOccurs="unbounded"/>
    </xs:sequence>
    <xs:attributeGroup

```

```

    ref="SQLTask:SqlTaskBaseAttributeGroup"/>
  <xs:attributeGroup
    ref="SQLTask:MaintenanceTaskBaseAttributeGroup"/>
  <xs:attributeGroup
    ref="SQLTask:UpdateStatisticsTaskAttributeGroup"/>
  <xs:attribute name="DatabaseSelectionType"
    type="SQLTask:SqlTaskDatabaseSelectionTypeEnum"/>
</xs:complexType>

```

2.6.4.11 ExecutableType Instance for Execute TSQL Task

An executable is an Execute TSQL Task executable if the **ExecutableType** attribute value is "Microsoft.SqlServer.Management.DatabaseMaintenance.DbMaintenanceTSQLExecuteTask, Microsoft.SqlServer.MaintenancePlanTasks, Version=11.0.0.0, Culture=neutral, PublicKeyToken=89845dcd8080cc91".

The Execute TSQL Task executable is formally defined to be of type [AnyNonPackageExecutableType](#). However, the following XSD fragment, which is expressed as an anonymous complex type declaration, places further restrictions on the type than the restrictions that are declared in the **AnyNonPackageExecutableType** type declaration. An [Executable](#) element with the **ExecutableType** attribute value equal to "Microsoft.SqlServer.Management.DatabaseMaintenance.DbMaintenanceTSQLExecuteTask, Microsoft.SqlServer.MaintenancePlanTasks, Version=11.0.0.0, Culture=neutral, PublicKeyToken=89845dcd8080cc91" MUST follow the anonymous type declaration that is contained in this section.

Note the following differences between this anonymous complex type declaration and the full definition of the complex type for the **AnyNonPackageExecutableType** type:

- This **Executable** element MUST NOT contain an **Executables** element.
- This **Executable** element MUST NOT contain a **ForEachEnumerators** element.
- This **Executable** element MUST NOT contain a **ForEachVariableMappings** element.
- In the **AnyNonPackageExecutableType** type, the type of the **ObjectData** element is given as [ExecutableObjectDataType](#). The **ExecutableObjectDataType** type definition contains an **xs:choice** XSD Schema element. However, all of the choices that are allowed in the **xs:choice** XSD Schema element are not available for the Execute TSQL Task executable. For this **Executable** element, the **ObjectData** element MUST contain the [SqlTaskData](#) element that is specified in the [SQLTask](#) namespace. The **SqlTaskData** element declaration in the **SQLTask** namespace MUST be replaced by the declaration and type that is specified in this section. This instance of the **SqlTaskData** element MUST contain zero elements. This instance of the **SqlTaskData** element MUST NOT contain attributes other than those that are specified in the [SqlTaskBaseAttributeGroup](#) attribute group and the [MaintenanceTaskBaseAttributeGroup](#) attribute group.
- The allowed attributes are a restricted subset of those that are allowed on the type, as specified in the [AnyNonPackageExecutableAttributeGroup](#) attribute group. Hence, the declaration of the attributes is replaced in this anonymous XSD fragment. The attributes used MUST be restricted to the ones that are shown as valid in the XSD fragment that is contained in this section.

```

<xs:complexType>
  <xs:sequence>

```

```

<xs:element name="ForEachEnumerators"
            type="DTS:ForEachEnumeratorsType"
            minOccurs="0" maxOccurs="0"/>
<xs:element name="Variables" type="DTS:VariablesType" minOccurs="0"/>
<xs:element name="LoggingOptions" type="DTS:LoggingOptionsType" />
<xs:element name="PropertyExpression"
            type="DTS:PropertyExpressionElementType" minOccurs="0"/>
<xs:element name="Executables" type="DTS:ExecutablesType"
            minOccurs="0" maxOccurs="0"/>
<xs:element name="PrecedenceConstraints"
            type="DTS:PrecedenceConstraintsType" minOccurs="0"/>
<xs:element name="ForEachVariableMappings"
            type="DTS:ForEachVariableMappingsType"
            minOccurs="0" maxOccurs="0"/>
<xs:element name="EventHandlers" type="DTS:EventHandlersType"
            minOccurs="0"/>
<xs:element name="ObjectData">
  <xs:complexType>
    <xs:choice>
      <xs:element ref="SQLTask:SqlTaskData"/>
    </xs:choice>
  </xs:complexType>
</xs:element>
</xs:sequence>
<xs:attribute name="ExecutableType" use="required">
  <xs:simpleType>
    <xs:restriction base="xs:string">
      <xs:enumeration
value="Microsoft.SqlServer.Management.DatabaseMaintenance.DbMaintenanceTSQLExecuteTask,
Microsoft.SqlServer.MaintenancePlanTasks, Version=11.0.0.0, Culture=neutral,
PublicKeyToken=89845dcd8080cc91"/>
    </xs:restriction>
  </xs:simpleType>
</xs:attribute>
<xs:attribute name="ThreadHint" use="optional" type="xs:int"/>
<xs:attributeGroup ref="DTS:BasePropertyAttributeGroup"/>
<xs:attributeGroup ref="DTS:BaseExecutablePropertyAttributeGroup"/>
<xs:attributeGroup ref="DTS:AllExecutableAttributeGroup"/>
<xs:attribute name="ExecutionLocation" type="xs:int" default="0"
use="optional" form="qualified"/>
<xs:attribute name="ExecutionAddress" type="xs:string" default=""
use="optional" form="qualified"/>
<xs:attribute name="TaskContact" type="xs:string" default=""
use="optional" form="qualified"/>
</xs:complexType>

```

The preceding anonymous complex type definition requires that the declaration for the **SqlTaskData** element and its type, which is specified in the **SQLTask** namespace, be changed to the following.

```

<xs:element name="SqlTaskData"
            type="SQLTask:SqlTaskDataElementTSQLExecuteTaskType"/>
<xs:complexType name="SqlTaskDataElementTSQLExecuteTaskType">
  <xs:sequence/>
  <xs:attributeGroup
    ref="SQLTask:SqlTaskBaseAttributeGroup"/>
</xs:complexType>

```

```

    ref="SQLTask:MaintenanceTaskBaseAttributeGroup"/>
</xs:complexType>

```

2.7 Executable ObjectData Types

2.7.1 ExecutableObjectDataType

The **ExecutableObjectDataType** type is the type of the **ObjectData** element that occurs as a child element of many [Executable](#) elements. The choice made within the **xs:Choice** XSD element is constrained by the value of the **ExecutableType** attribute on the **Executable** element. These constraints **MUST** be adhered to. The constraint for each **ExecutableType** value is explained in [ExecutableType Attribute Values for Different Executable Types](#).

The following is the XSD of the **ExecutableObjectDataType** type.

```

<xs:complexType name="ExecutableObjectDataType">
  <xs:choice minOccurs="0">
    <xs:element name="pipeline" type="DTS:pipelineObjectDataType"
      form="unqualified"/>
    <xs:element ref="ActiveXScriptTask:ActiveXScriptTaskData" />
    <xs:element name="ASDdlData" type="DTS:ASDdlDataObjectDataType"
      form="unqualified"/>
    <xs:element name="ASProcessingData" form="unqualified"
      type="DTS:ASProcessingDataObjectDataType"/>
    <xs:element ref="BulkInsertTask:BulkInsertTaskData"/>
    <xs:element name="DMQueryTaskData" form="unqualified"
      type="DTS:DMQueryTaskDataObjectDataType"/>
    <xs:element name="DataProfilingTaskData" form="unqualified"
      type="DTS:DataProfilingTaskDataObjectDataType"/>
    <xs:element ref="Exec80PackageTask:Exec80PackageTaskData"/>
    <xs:element name="ExecutePackageTask" form="unqualified"
      type="DTS:ExecutePackageTaskObjectDataType"/>
    <xs:element name="ExecuteProcessData" form="unqualified"
      type="DTS:ExecuteProcessDataObjectDataType"/>
    <xs:element ref="SQLTask:SqlTaskData"/>
    <xs:element name="FileSystemData" form="unqualified"
      type="DTS:FileSystemDataObjectDataType"/>
    <xs:element name="FtpData" type="DTS:FtpDataObjectDataType"
      form="unqualified"/>
    <xs:element ref="MessageQueueTask:MessageQueueTaskData"/>
    <xs:element name="ScriptProject" type="DTS:ScriptProjectObjectDataType"
      form="unqualified"/>
    <xs:element ref="SendMailTask:SendMailTaskData"/>
    <xs:element name="TransferDatabasesTaskData" form="unqualified"
      type="DTS:TransferDatabasesTaskDataObjectDataType"/>
    <xs:element name="TransferErrorMessagesTaskData" form="unqualified"
      type="DTS:TransferErrorMessagesTaskDataObjectDataType"/>
    <xs:element name="TransferJobsTaskData" form="unqualified"
      type="DTS:TransferJobsTaskDataObjectDataType"/>
    <xs:element name="TransferLoginsTaskData" form="unqualified"
      type="DTS:TransferLoginsTaskDataObjectDataType"/>
    <xs:element name="TransferStoredProceduresTaskData" form="unqualified"
      type="DTS:TransferStoredProceduresTaskDataObjectDataType"/>
    <xs:element name="TransferSqlServerObjectsTaskData" form="unqualified"
      type="DTS:TransferSqlServerObjectsTaskDataObjectDataType"/>
  </xs:choice>
</xs:complexType>

```



```

<xs:element ref="WSTask:WebServiceTaskData"/>
<xs:element name="WMIDRTaskData" type="DTS:WMIDRTaskDataObjectDataType"
  form="unqualified"/>
<xs:element name="WMIEWTaskData" type="DTS:WMIEWTaskDataObjectDataType"
  form="unqualified"/>
<xs:element name="XMLTaskData" type="DTS:XMLTaskDataObjectDataType"
  form="unqualified"/>
<xs:element name="InnerObject" type="DTS:InnerObjectObjectDataType"
  form="unqualified"/>
</xs:choice>
</xs:complexType>

```

2.7.1.1 pipelineObjectType

The **pipelineObjectType** complex type is used to specify the parameters, properties, and settings that are specific to a Pipeline executable.

The following is the XSD for the **pipelineObjectType** complex type.

```

<xs:complexType name="pipelineObjectType">
  <xs:sequence>
    <xs:sequence>
      <xs:element name="components" type="DTS:PipelineComponentsType"
        form="unqualified"/>
      <xs:element name="paths" type="DTS:PipelinePathsType"
        minOccurs="0" form="unqualified"/>
    </xs:sequence>
  </xs:sequence>
  <xs:attribute name="id" type="xs:int" form="unqualified"
    use="required"/>
  <xs:attribute name="name" type="xs:string" form="unqualified"
    use="optional" default=""/>
  <xs:attribute name="version" type="xs:int" form="unqualified"
    use="optional" fixed="1"/>
  <xs:attribute name="description" type="xs:string"
    use="optional" default="" form="unqualified"/>
  <xs:attribute name="defaultBufferMaxRows" type="xs:int"
    use="optional" default="10000" form="unqualified"/>
  <xs:attribute name="engineThreads" type="xs:int"
    use="optional" default="10" form="unqualified"/>
  <xs:attribute name="defaultBufferSize" type="xs:int"
    use="optional" default="10485760" form="unqualified"/>
  <xs:attribute name="BLOBTempStoragePath" type="xs:string"
    use="optional" default="" form="unqualified"/>
  <xs:attribute name="bufferTempStoragePath" type="xs:string"
    use="optional" default="" form="unqualified"/>
  <xs:attribute name="runInOptimizedMode" type="xs:boolean"
    use="optional" default="true" form="unqualified"/>
</xs:complexType>

```

The following table specifies the elements of the **pipelineObjectType** complex type.

Element	Type definition	Description
components	PipelineComponentsType	A complex type that specifies a collection of component elements. Each component element represents one node of the pipeline process.
paths	PipelinePathsType	A complex type that specifies a collection of path elements. Each path element represents one path of data flow within the pipeline process.

The following table specifies the attributes of the **pipelineObjectDataType** complex type.

Attribute	Description
id	An integer value that specifies the identifier for this pipeline element. Other elements can refer to this pipeline element by using this id value.
name	A string value that specifies the name for this pipeline element.
version	An integer value that specifies the version. A value of 1 specifies Microsoft® SQL Server® 2012. A missing value indicates a previous version of Microsoft® SQL Server®. Values for future versions of SQL Server will be added.
description	A string value that specifies the description for this pipeline element.
defaultBufferMaxRows	An integer value that specifies the maximum number of rows for the default buffer. <25>
engineThreads	An integer value that specifies a suggestion to the data flow engine about the number of threads to use. <26>
defaultBufferSize	An integer value that specifies the number of bytes to allocate by default for temporary buffer storage. <27>
BLOBTempStoragePath	A string value that specifies a folder that is used for temporary storage of BLOB columns during the execution of the task. <28>
bufferTempStoragePath	A string value that specifies a folder that is used for temporary buffer storage during the execution of the task. <29>
runInOptimizedMode	A Boolean value that specifies whether to run the task in optimized mode. Optimized mode removes unused columns, outputs, and components from the data flow. TRUE specifies that the task is run in optimized mode. FALSE specifies that the task is not run in optimized mode.

2.7.1.1.1 PipelineComponentsType

The **PipelineComponentsType** complex type specifies a collection of component objects for a Pipeline executable.

The following is the XSD for the **PipelineComponentsType** complex type.

```
<xs:complexType name="PipelineComponentsType">
  <xs:sequence>
```

```

    <xs:element name="component" type="DTS:PipelineComponentType"
      form="unqualified" maxOccurs="unbounded"/>
  </xs:sequence>
</xs:complexType>

```

The following table specifies the elements of the **PipelineComponentsType** complex type.

Element	Type definition	Description
Component	PipelineComponentType	A complex type that specifies a single component within a pipeline.

2.7.1.1.1 PipelineComponentType

The **PipelineComponentType** complex type specifies a single component within a Pipeline executable. Each component represents a single operation within a **Pipeline Task**.

The following is the XSD for the **PipelineComponentType** complex type.

```

<xs:complexType name="PipelineComponentType">
  <xs:sequence>
    <xs:element name="properties" form="unqualified"
      type="DTS:PipelineComponentPropertiesType"
      minOccurs="0"/>
    <xs:element name="connections" form="unqualified"
      type="DTS:PipelineComponentConnectionsType"
      minOccurs="0"/>
    <xs:element name="inputs" form="unqualified"
      type="DTS:PipelineComponentInputsType"
      minOccurs="0"/>
    <xs:element name="outputs" form="unqualified"
      type="DTS:PipelineComponentOutputsType"
      minOccurs="0"/>
  </xs:sequence>
  <xs:attribute name="name" type="xs:string" form="unqualified"
    use="optional" default=""/>
  <xs:attribute name="refId" type="xs:string" use="required"
    form="unqualified"/>
  <xs:attribute name="componentClassID" use="required"
    type="DTS:PipelineComponentComponentClassIDEnum"
    form="unqualified"/>
  <xs:attribute name="description" type="xs:string"
    form="unqualified" use="optional" default=""/>
  <xs:attribute name="localeId" type="xs:int" use="optional"
    default="-1" form="unqualified"/>
  <xs:attribute name="usesDispositions" type="xs:boolean"
    use="optional" default="false" form="unqualified"/>
  <xs:attribute name="validateExternalMetadata" form="unqualified"
    use="optional" default="True">
    <xs:simpleType>
      <xs:restriction base="xs:string">
        <xs:enumeration value="True"/>
        <xs:enumeration value="False"/>
      </xs:restriction>
    </xs:simpleType>
  </xs:attribute>

```

```

</xs:attribute>
<xs:attribute name="version" type="xs:int" use="optional"
  default="0" form="unqualified"/>
<xs:attribute name="pipelineVersion" type="xs:int"
  use="optional" default="0" form="unqualified"/>
<xs:attribute name="contactInfo" type="xs:string"
  use="optional" default="" form="unqualified"/>
</xs:complexType>

```

The following table specifies the elements of the **PipelineComponentType** complex type.

Element	Type definition	Description
properties	PipelineComponentPropertiesType	A complex type that specifies a collection of property elements for the component.
connections	PipelineComponentConnectionsType	A complex type that specifies a collection of connection elements for the component.
inputs	PipelineComponentInputsType	A complex type that specifies a collection of input elements that represent inputs arriving at this component.
outputs	PipelineComponentOutputsType	A complex type that specifies a collection of output elements that represent outputs coming from this component.

The following table specifies the attributes of the **PipelineComponentType** complex type.

Attribute	Description
name	A string value that specifies the name for this component element.
refId	A string value that specifies a unique refId for this object. Elsewhere within the containing executable or within the package, the value of refId can be used to refer to this object. <30>
componentClassId	An enumeration value that specifies the Class ID for this component.
description	A string value that specifies the description for this component element.
localeId	An integer value that specifies the LCID for this component element.
usesDispositions	A Boolean value that specifies whether the component has an output path for errors. TRUE specifies that the component has an output path for errors. FALSE specifies that the component does not have an output path for errors.
validateExternalMetadata	The validateExternalMetadata attribute value is not used by the data transformation processing engine. <31>
version	An integer value that specifies the version of the component.
pipelineVersion	An integer value that specifies the version of the task within which a component is designed to execute.

Attribute	Description
contactInfo	A string value that specifies contact information for the developer of a component. <32>

2.7.1.1.1.1.1 PipelineComponentPropertiesType

The **PipelineComponentPropertiesType** complex type specifies a collection of properties of the component.

The following is the XSD for the **PipelineComponentPropertiesType** complex type.

```
<xs:complexType name="PipelineComponentPropertiesType">
  <xs:sequence>
    <xs:element name="property" form="unqualified"
      type="DTS:PipelineComponentPropertyType"
      minOccurs="0" maxOccurs="unbounded"/>
  </xs:sequence>
</xs:complexType>
```

The following table specifies the elements of the **PipelineComponentPropertiesType** complex type.

Element	Type definition	Description
property	PipelineComponentPropertyType	A complex type that specifies a property of a component or of a component input, output, or metadata column.

2.7.1.1.1.1.1.1 PipelineComponentPropertyType

The **PipelineComponentPropertyType** complex type specifies the structure in which the value for a single property of a component is held. All components do not use the same set of properties, so this general structure is designed to hold the variety of properties that a component can have.

The following is the XSD for the **PipelineComponentPropertyType** complex type.

```
<xs:complexType name="PipelineComponentPropertyType" mixed="true">
  <xs:sequencef>
    <xs:element name="arrayElements"
      type="DTS:PipelineComponentArrayElementsType"
      form="unqualified" minOccurs="0"/>
  </xs:sequence>
  <xs:attribute name="name" use="required"
    type="DTS:PipelineComponentPropertyNameEnum"
    form="unqualified"/>
  <xs:attributeGroup
    ref="DTS:PipelineComponentPropertyAttributeGroup"/>
</xs:complexType>
```

The following table specifies the elements of the **PipelineComponentPropertyType** complex type.

Element	Type definition	Description
arrayElements	PipelineComponentArrayElementsType	A complex type that contains a collection of elements that form an array. The collection constitutes the value for the property. This type is used only if the isArray attribute value is TRUE.

The following table specifies the attributes of the **PipelineComponentPropertyType** complex type.

Attribute	Description
PipelineComponentPropertyAttributeGroup	An attribute group that contains attributes that are common to all property elements for input elements, output elements, inputColumn elements, and outputColumn elements.
name	A string value that specifies the name of the property.

2.7.1.1.1.1.1.1.1 PipelineComponentArrayElementsType

The **PipelineComponentArrayElementsType** complex type specifies a collection of component objects for a Pipeline executable.

The following is the XSD for the **PipelineComponentArrayElementsType** complex type.

```
<xs:complexType name="PipelineComponentArrayElementsType">
  <xs:sequence>
    <xs:element name="arrayElement"
      type="DTS:PipelineComponentArrayType"
      form="unqualified" minOccurs="0" maxOccurs="unbounded"/>
  </xs:sequence>
  <xs:attribute name="arrayElementCount" type="xs:int"
    form="unqualified"/>
</xs:complexType>
```

The following table specifies the elements of the **PipelineComponentArrayElementsType** type.

Element	Type definition	Description
arrayElement	PipelineComponentArrayType	A complex type that specifies a single array element that is a member of the array of elements that is the value of a pipeline property.

2.7.1.1.1.1.1.1.1.1 PipelineComponentArrayType

The **PipelineComponentArrayType** complex type specifies a collection of component objects for a Pipeline executable.

The following is the XSD for the **PipelineComponentArrayType** complex type.

```

<xs:complexType name="PipelineComponentArrayType">
  <xs:simpleContent>
    <xs:extension base="xs:anySimpleType">
      <xs:attribute name="dataType"
        type="DTS:PipelineComponentDataTypeEnum"
        form="unqualified"/>
    </xs:extension>
  </xs:simpleContent>
</xs:complexType>

```

The following table specifies the attributes of the **PipelineComponentArrayType** complex type.

Attribute	Description
dataType	An enumeration value that specifies the type of the data that is contained in the value for the array element.

2.7.1.1.1.1.1.2 PipelineComponentPropertyNameEnum

The **PipelineComponentPropertyNameEnum** type contains the allowed values for the **name** attribute on the **component** element of a Pipeline executable. The allowed values for the **property** element for each task are more restricted than the values that are specified formally by the XSD.

Each **name** attribute value MUST NOT be used for any component except for the components that are specified in the subsections of this section. Some components allow no properties.

The additional restrictions specified in the subsections of this section MUST be followed for the **name** attribute on the **property** element children of the **component** element.

```

<xs:simpleType name="PipelineComponentPropertyNameEnum">
  <xs:restriction base="xs:string">
    <!--Transforms-->
    <!--Aggregate Task-->
    <xs:enumeration value="KeyScale"/>
    <xs:enumeration value="Keys"/>
    <xs:enumeration value="CountDistinctScale"/>
    <xs:enumeration value="CountDistinctKeys"/>
    <xs:enumeration value="AutoExtendFactor"/>
    <!--Audit (none)-->
    <!--Cache Transform (none)-->
    <!--Character Map (none)-->
    <!--Conditional Split (none)-->
    <!--Copy Column (none)-->
    <!--Data Conversion (none)-->
    <!--Data Mining Query-->
    <xs:enumeration value="ObjectRef"/>
    <xs:enumeration value="QueryText"/>
    <xs:enumeration value="CatalogName"/>
    <!--Derived Column Query (none)-->
    <!--Export Column Query (none)-->
    <!--Fuzzy Grouping-->
    <xs:enumeration value="MinSimilarity"/>
    <xs:enumeration value="Delimiters"/>
    <xs:enumeration value="MaxMemoryUsage"/>
  </xs:restriction>
</xs:simpleType>

```

```

<xs:enumeration value="Exhaustive"/>
<!--Fuzzy Lookup-->
<xs:enumeration value="MatchIndexOptions"/>
<xs:enumeration value="MaxMemoryUsage"/>
<xs:enumeration value="MatchIndexName"/>
<xs:enumeration value="ReferenceTableName"/>
<xs:enumeration value="DropExistingMatchIndex"/>
<xs:enumeration value="CopyReferenceTable"/>
<xs:enumeration value="MaxOutputMatchesPerInput"/>
<xs:enumeration value="MinSimilarity"/>
<xs:enumeration value="Delimiters"/>
<xs:enumeration value="ReferenceMetadataXml"/>
<xs:enumeration value="Exhaustive"/>
<xs:enumeration value="WarmCaches"/>
<!--Import Column (none)-->
<!--Lookup-->
<xs:enumeration value="SqlCommand"/>
<xs:enumeration value="SqlCommandParam"/>
<xs:enumeration value="ConnectionType"/>
<xs:enumeration value="CacheType"/>
<xs:enumeration value="NoMatchBehavior"/>
<xs:enumeration value="NoMatchCachePercentage"/>
<xs:enumeration value="MaxMemoryUsage"/>
<xs:enumeration value="MaxMemoryUsage64"/>
<xs:enumeration value="ReferenceMetadataXml"/>
<xs:enumeration value="ParameterMap"/>
<xs:enumeration value="DefaultCodePage"/>
<!--Merge (none)-->
<!--MergeJoin (none)-->
<xs:enumeration value="JoinType"/>
<xs:enumeration value="NumKeyColumns"/>
<xs:enumeration value="TreatNullsAsEqual"/>
<xs:enumeration value="MaxBuffersPerInput"/>
<!--Multicast (none)-->
<!--OLE DB Command-->
<xs:enumeration value="CommandTimeout"/>
<xs:enumeration value="SqlCommand"/>
<xs:enumeration value="DefaultCodePage"/>
<!--Percentage Sampling-->
<xs:enumeration value="SamplingValue"/>
<xs:enumeration value="SamplingSeed"/>
<!--Pivot (none)-->
<!--RowCount-->
<xs:enumeration value="VariableName"/>
<!--Row Sampling-->
<xs:enumeration value="SamplingValue"/>
<xs:enumeration value="SamplingSeed"/>
<!--Script Component-->
<xs:enumeration value="SourceCode"/>
<xs:enumeration value="BinaryCode"/>
<xs:enumeration value="VSTAProjectName"/>
<xs:enumeration value="ScriptLanguage"/>
<xs:enumeration value="ReadOnlyVariables"/>
<xs:enumeration value="ReadWriteVariables"/>
<xs:enumeration value="BreakpointCollection"/>
<xs:enumeration value="UserComponentTypeName"/>
<!--Slowly Changing Dimension-->
<xs:enumeration value="SqlCommand"/>
<xs:enumeration value="CurrentRowWhere"/>

```



```

<xs:enumeration value="UpdateChangingAttributeHistory"/>
<xs:enumeration value="FailOnFixedAttributeChange"/>
<xs:enumeration value="InferredMemberIndicator"/>
<xs:enumeration value="EnableInferredMember"/>
<xs:enumeration value="FailOnLookupFailure"/>
<xs:enumeration value="IncomingRowChangeType"/>
<xs:enumeration value="DefaultCodePage"/>
<!--Sort-->
<xs:enumeration value="EliminateDuplicates"/>
<xs:enumeration value="MaximumThreads"/>
<!--Term Extraction-->
<xs:enumeration value="NeedReferenceData"/>
<xs:enumeration value="OutTermTable"/>
<xs:enumeration value="OutTermColumn"/>
<xs:enumeration value="WordOrPhrase"/>
<xs:enumeration value="ScoreType"/>
<xs:enumeration value="FrequencyThreshold"/>
<xs:enumeration value="MaxLengthOfTerm"/>
<xs:enumeration value="IsCaseSensitive"/>
<!--Term Lookup-->
<xs:enumeration value="RefTermTable"/>
<xs:enumeration value="RefTermColumn"/>
<xs:enumeration value="IsCaseSensitive"/>
<!--UnionAll (none)-->
<!--Unpivot (none)-->
<!--Data Destinations-->
<!--ADO.Net Destination-->
<xs:enumeration value="TableOrViewName"/>
<xs:enumeration value="BatchSize"/>
<xs:enumeration value="CommandTimeout"/>
<xs:enumeration value="UserComponentTypeName"/>
<!--Excel Destination-->
<xs:enumeration value="CommandTimeout"/>
<xs:enumeration value="OpenRowset"/>
<xs:enumeration value="OpenRowsetVariable"/>
<xs:enumeration value="SqlCommand"/>
<xs:enumeration value="AccessMode"/>
<xs:enumeration value="FastLoadKeepIdentity"/>
<xs:enumeration value="FastLoadKeepNulls"/>
<xs:enumeration value="FastLoadOptions"/>
<xs:enumeration value="FastLoadMaxInsertCommitSize"/>
<!--Flat File Destination-->
<xs:enumeration value="Overwrite"/>
<xs:enumeration value="Header"/>
<!--OLE DB Destination-->
<xs:enumeration value="CommandTimeout"/>
<xs:enumeration value="OpenRowset"/>
<xs:enumeration value="OpenRowsetVariable"/>
<xs:enumeration value="SqlCommand"/>
<xs:enumeration value="DefaultCodePage"/>
<xs:enumeration value="AlwaysUseDefaultCodePage"/>
<xs:enumeration value="AccessMode"/>
<xs:enumeration value="FastLoadKeepIdentity"/>
<xs:enumeration value="FastLoadKeepNulls"/>
<xs:enumeration value="FastLoadOptions"/>
<xs:enumeration value="FastLoadMaxInsertCommitSize"/>
<!--Raw File Destination-->
<xs:enumeration value="AccessMode"/>
<xs:enumeration value="FileName"/>

```

```

<xs:enumeration value="FileNameVariable"/>
<xs:enumeration value="WriteOption"/>
<!--DataReader Destination-->
<xs:enumeration value="ReadTimeout"/>
<xs:enumeration value="DataReader"/>
<xs:enumeration value="FailOnTimeout"/>
<xs:enumeration value="UserComponentTypeName"/>
<!--Data Mining Model Training-->
<xs:enumeration value="ObjectRef"/>
<!--Dimension Processing-->
<xs:enumeration value="ObjectRef"/>
<xs:enumeration value="UseDefaultConfiguration"/>
<xs:enumeration value="KeyErrorLimit"/>
<xs:enumeration value="KeyErrorLogFile"/>
<xs:enumeration value="KeyErrorAction"/>
<xs:enumeration value="KeyErrorLimitAction"/>
<xs:enumeration value="KeyNotFound"/>
<xs:enumeration value="KeyDuplicate"/>
<xs:enumeration value="NullKeyConvertedToUnknown"/>
<xs:enumeration value="NullKeyNotAllowed"/>
<xs:enumeration value="ProcessType"/>
<!--Partition Processing-->
<xs:enumeration value="ObjectRef"/>
<xs:enumeration value="UseDefaultConfiguration"/>
<xs:enumeration value="KeyErrorLimit"/>
<xs:enumeration value="KeyErrorLogFile"/>
<xs:enumeration value="KeyErrorAction"/>
<xs:enumeration value="KeyErrorLimitAction"/>
<xs:enumeration value="KeyNotFound"/>
<xs:enumeration value="KeyDuplicate"/>
<xs:enumeration value="NullKeyConvertedToUnknown"/>
<xs:enumeration value="NullKeyNotAllowed"/>
<xs:enumeration value="ProcessType"/>
<!--RecordSet Destination-->
<xs:enumeration value="VariableName"/>
<!--SQL Server Compact Destination-->
<xs:enumeration value="Table Name"/>
<xs:enumeration value="UserComponentTypeName"/>
<!--SQL Server Destination-->
<xs:enumeration value="DefaultCodePage"/>
<xs:enumeration value="AlwaysUseDefaultCodePage"/>
<xs:enumeration value="BulkInsertTableName"/>
<xs:enumeration value="BulkInsertCheckConstraints"/>
<xs:enumeration value="BulkInsertFirstRow"/>
<xs:enumeration value="BulkInsertFireTriggers"/>
<xs:enumeration value="BulkInsertKeepIdentity"/>
<xs:enumeration value="BulkInsertKeepNulls"/>
<xs:enumeration value="BulkInsertLastRow"/>
<xs:enumeration value="BulkInsertMaxErrors"/>
<xs:enumeration value="BulkInsertOrder"/>
<xs:enumeration value="BulkInsertTablock"/>
<xs:enumeration value="Timeout"/>
<xs:enumeration value="MaxInsertCommitSize"/>
<!--Data Sources-->
<!--ADO.Net Source-->
<xs:enumeration value="SqlCommand"/>
<xs:enumeration value="CommandTimeout"/>
<xs:enumeration value="AllowImplicitStringConversion"/>
<xs:enumeration value="TableOrViewName"/>

```

```

<xs:enumeration value="AccessMode"/>
<xs:enumeration value="UserComponentTypeName"/>
<!--Excel Source-->
<xs:enumeration value="CommandTimeout"/>
<xs:enumeration value="OpenRowset"/>
<xs:enumeration value="OpenRowsetVariable"/>
<xs:enumeration value="SqlCommand"/>
<xs:enumeration value="SqlCommandVariable"/>
<xs:enumeration value="AccessMode"/>
<xs:enumeration value="ParameterMapping"/>
<!--Flat File Source-->
<xs:enumeration value="RetainNulls"/>
<xs:enumeration value="FileNameColumnName"/>
<!--OLEDB Source Task-->
<xs:enumeration value="CommandTimeout"/>
<xs:enumeration value="OpenRowset"/>
<xs:enumeration value="OpenRowsetVariable"/>
<xs:enumeration value="SqlCommand"/>
<xs:enumeration value="SqlCommandVariable"/>
<xs:enumeration value="DefaultCodePage"/>
<xs:enumeration value="AlwaysUseDefaultCodePage"/>
<xs:enumeration value="AccessMode"/>
<xs:enumeration value="ParameterMapping"/>
<!--Raw File Source-->
<xs:enumeration value="AccessMode"/>
<xs:enumeration value="FileName"/>
<xs:enumeration value="FileNameVariable"/>
<!--XML Source-->
<xs:enumeration value="UserComponentTypeName"/>
<xs:enumeration value="XMLData"/>
<xs:enumeration value="XMLDataVariable"/>
<xs:enumeration value="AccessMode"/>
<xs:enumeration value="XMLSchemaDefinition"/>
<xs:enumeration value="UseInlineSchema"/>
</xs:restriction>
</xs:simpleType>

```

This section contains no tabular explanation of the properties that are specified in the XSD in this section. Tabular explanations are contained in the appropriate subsection where a particular value is allowed.

2.7.1.1.1.1.1.2.1 Aggregate Component

The **Aggregate Component** MUST NOT use any **Name** attribute value on a **property** element except for those that are listed in the table in this section.

The following table specifies the **Name** attribute values that are allowed for the Aggregate Component, in addition to any restrictions on the element value. These restrictions MUST be followed.

Name attribute value	Description
KeyScale	The property element value MUST be an integer between 0 and 3. This value specifies the approximate number of groups that is expected by the operation. This value is used to optimize computation. The enumeration values are

Name attribute value	Description
	interpreted as follows: 0 – The key scale is not used. 1 – Aggregation writes approximately 500,000 keys. 2 – Aggregation writes approximately 25,000,000 keys. 3– Aggregation writes more than 25,000,000 keys.
Keys	The property element value MUST be an integer. This value specifies the number of groups that is expected by the operation. This value is used to optimize computation. If this value is specified, it overrides the value that is specified for the KeyScale attribute.
CountDistinctScale	The property element value MUST be an integer between 0 and 3. This value specifies the approximate number of groups that is expected by a distinct count operation. This value is used to optimize computation. The enumeration values are interpreted as follows: 0 – The key scale is not used. 1 – Aggregation writes approximately 500,000 keys. 2 – Aggregation writes approximately 25,000,000 keys. 3– Aggregation writes more than 25,000,000 keys.
CountDistinctKeys	The property element value MUST be an integer. This value specifies the number of groups that is expected by a distinct count operation. This value is used to optimize computation. If this value is specified, it overrides the value that is specified for the CountDistinctKeys attribute.
AutoExtendFactor	The property element value MUST be an integer. This value specifies the percentage amount by which memory is extended during the aggregate operation.

2.7.1.1.1.1.1.2.2 Audit Component

The **Audit Component** MUST NOT have any properties.

2.7.1.1.1.1.1.2.3 Cache Transform Component

The **Cache Transform Component** MUST NOT have any properties.

2.7.1.1.1.1.1.2.4 Character Map Component

The **Character Map Component** MUST NOT have any properties.

2.7.1.1.1.1.1.2.5 Conditional Split Component

The **Conditional Split Component** MUST NOT have any properties.

2.7.1.1.1.1.1.2.6 Copy Column Component

The **Copy Column Component** MUST NOT have any properties.

2.7.1.1.1.1.1.2.7 Data Conversion Component

The **Data Conversion Component** MUST NOT have any properties.

2.7.1.1.1.1.1.2.8 Data Mining Query Component

The **Data Mining Query Component** MUST NOT use any **name** attribute value on a **property** element except for those that are listed in the table in this section.

The following table specifies the **Name** attribute values that are allowed for the Data Mining Query Component, in addition to any restrictions on the element value. These restrictions MUST be followed.

Name attribute value	Description
ObjectRef	A string value that specifies an XML tag that identifies the mining structure that the task uses.
QueryText	A string value that specifies a Data Mining Query Language (DMX) query string. For more information about the DMX language, see [MSDN-DMXR] .
CatalogName	A string value that specifies the catalog name in the host database for the data mining model.

2.7.1.1.1.1.1.2.9 Derived Column Component

The **Derived Column Component** MUST NOT have any properties.

2.7.1.1.1.1.1.2.10 Export Column Component

The **Export Column Component** MUST NOT have any properties.

2.7.1.1.1.1.1.2.11 Fuzzy Grouping Component

The **Fuzzy Grouping Component** MUST NOT use any **name** attribute value on a **property** element except for those that are listed in the table in this section.

The following table specifies the **Name** attribute values that are allowed for the Fuzzy Grouping Component, in addition to any restrictions on the element value. All stated restrictions MUST be followed.

Name attribute value	Description
MinSimilarity	The property element value MUST be a single precision number between 0 and 1. This value specifies the similarity threshold that the task uses to identify duplicates.
Delimiters	The property element value MUST be a string. This value specifies the tokens that the task uses as delimiters.
MaxMemoryUsage	The property element value MUST be an integer. This value specifies the maximum memory usage for the task in bytes. <33>
Exhaustive	The property element value MUST be a Boolean. This value specifies whether each input record is compared to every other input record. TRUE specifies that each input record is compared to every other input record. FALSE specifies that each input record is not compared to every other input record.

2.7.1.1.1.1.1.2.12 Fuzzy Lookup Component

The **Fuzzy Lookup Component** MUST NOT use any **Name** attribute value on a property element except for those that are listed in the table in this section.

The following table specifies the **Name** attribute values that are allowed for the Fuzzy Lookup Component, in addition to any restrictions on the element value. All stated restrictions MUST be followed.

Name attribute value	Description
MatchIndexOptions	The property element value MUST be an integer between 0 and 3. This value specifies how the match index is managed. The values have the following meanings: 0 – Reuse existing index. 1 – Generate a new index. 2 – Generate and persist a new index. 3 – Generate and maintain a new index.
MaxMemoryUsage	The property element value MUST be an integer. This value specifies the maximum size for the cache table in bytes. .<34>
MatchIndexName	The property element value MUST be a string. This value specifies the name of the match index. The match index is the table in which the transformation creates and saves the index that it uses.
ReferenceTableName	The property element value MUST be a string value. This value specifies the name of the lookup table. .<35>
DropExistingMatchIndex	The property element value MUST be a Boolean value. This value specifies whether the match index that is specified in the MatchIndexName attribute is deleted when the MatchIndexOptions attribute is not set to the value "ReuseExistingIndex".
CopyReferenceTable	The property element value MUST be a Boolean value. This value specifies whether a copy of the reference table is made for index construction and for subsequent lookups. TRUE specifies that a copy of the reference table is be made. FALSE specifies that a copy of the reference table is not made.
MaxOutputMatchesPerInput	The property element value MUST be an integer. This value specifies the maximum number of matches that can be returned for each input row.
MinSimilarity	The property element value MUST be a single precision number between 0 and 1. This value specifies the similarity threshold that the task uses to identify duplicates.
Delimiters	The property element value MUST be a string. This value specifies the tokens that the task uses as delimiters.
ReferenceMetadataXml	The property element value MUST be a string. .<36>
Exhaustive	The property element value MUST be a Boolean. This value specifies whether each input record is compared to every other input record. TRUE specifies that each input record is compared to every other input record. FALSE specifies that each input record is not compared to every other

Name attribute value	Description
	input record.
WarmCaches	The property element value MUST be a Boolean. This value specifies whether the index and reference table are partially loaded into memory before the operation begins. TRUE specifies that the index and reference table are partially loaded into memory before the operation begins. FALSE specifies that the index and reference table are not partially loaded into memory before the operation begins.

2.7.1.1.1.1.1.2.13 Import Column Component

The **Import Column Component** MUST NOT have any properties.

2.7.1.1.1.1.1.2.14 Lookup Component

The **Lookup Component** MUST NOT use any **Name** attribute value on a **property** element except for those that are listed in the table in this section.

The following table specifies the **Name** attribute values that are allowed for the Lookup Component, in addition to any restrictions on the element value. These restrictions MUST be followed.

Name attribute value	Description
SqlCommand	The property element value MUST be a string value. This value specifies an SQL SELECT command string that populates the lookup table.
SqlCommandParam	The property element value MUST be a string value. This value specifies a parameterized SQL statement that populates the lookup table.
ConnectionType	The property element value MUST be an integer between 0 and 1. This value specifies the connection type. The allowed values are the following: 0 – The connection is OLE DB. 1 – The connection is to a cache.
CacheType	The property element value MUST be an integer between 0 and 2. This enumeration value specifies the cache type for the lookup table. The allowed values are interpreted as follows: 0 – Full. 1 – Partial. 2 – No cache.
NoMatchBehavior	The property element value MUST be an integer between 0 and 1. This enumeration value specifies the behavior when rows with no matching value in the reference dataset are encountered in the data flow. The allowed values are interpreted as follows: 0 – Rows with no matching entries are treated as errors. 1 – Rows with no matching entries are sent to the “no match” output.
NoMatchCachePercentage	The property value MUST be an integer between 0 and 100. The value specifies the maximum percentage of cache memory that can be allocated to data for which a match has not been found.

Name attribute value	Description
MaxMemoryUsage	The property element value MUST be an integer. This value specifies the maximum memory size in megabytes for the cache on a 32-bit platform.
MaxMemoryUsage64	The property element value MUST be an integer. This value specifies the maximum memory size in megabytes for the cache on a 64-bit platform.
ReferenceMetadataXml	The property element value MUST be a string. <37>
ParameterMap	The property element value MUST be a string. This value specifies the parameters that are mapped to the SQL command. The string is delimited by a semicolon.
DefaultCodePage	The property element value MUST be an integer. This value specifies the default code page to use if code page information is not available from the data source.

2.7.1.1.1.1.1.2.15 Merge Component

The **Merge Component** MUST NOT have any properties.

2.7.1.1.1.1.1.2.16 MergeJoin Component

The **MergeJoin Component** MUST NOT use any **Name** attribute value on a **property** element except for those that are listed in the table in this section.

The following table specifies the **Name** attribute values that are allowed for the MergeJoin Component, in addition to any restrictions on the element value. These restrictions MUST be followed.

Name attribute value	Description
JoinType	The property element value MUST be an integer value between 0 and 2. This value specifies the type of join to be performed. The interpretation of the enumeration values is as follows. 0 – Full join. 1 – Left outer join. 2 – Inner join.
NumKeyColumns	The property element value MUST be an integer. This value specifies the number of key columns used in the join.
TreatNullsAsEqual	The property element value MUST be a Boolean value. This value specifies whether NULL values are treated as equal for the purpose of a join. TRUE specifies that NULL values are treated as equal. FALSE specifies that NULL values are not treated as equal and are treated as they are normally treated by the database server.
MaxBuffersPerInput	The property element value MUST be an integer. This value specifies the maximum number of buffers that is used per input.

2.7.1.1.1.1.1.2.17 Multicast Component

The **Multicast Component** MUST NOT have any properties.

2.7.1.1.1.1.1.2.18 OLE DB Command Component

The **OLE DB Command Component** MUST NOT use any **Name** attribute value on a **property** element except for those that are listed in the table in this section.

The following table specifies the **Name** attribute values that are allowed for the OLE DB Command Component, in addition to any restrictions on the element value. These restrictions MUST be followed.

Name attribute value	Description
CommandTimeout	The property element value MUST be an integer. This value specifies the timeout interval, in seconds, for the command.
SqlCommand	The property element value MUST be a string value. This value specifies the SQL command string.
DefaultCodePage	The property element value MUST be an integer. This value specifies the default code page to use if the code page is not available from the data source.

2.7.1.1.1.1.1.2.19 Percentage Sampling Component

The **Percentage Sampling Component** MUST NOT use any **Name** attribute value on a **property** element except for those that are listed in the table in this section.

The following table specifies the **Name** attribute values that are allowed for the Percentage Sampling Component, in addition to any restrictions on the element value. These restrictions MUST be followed.

Name attribute value	Description
SamplingValue	The property element value MUST be an integer. This value represents the percentage of the source that is taken as a sample.
SamplingSeed	The property element value MUST be an integer. This value specifies the random number generator seed that is used for generating a random sample.

2.7.1.1.1.1.1.2.20 Pivot Component

The **Pivot Component** MUST NOT have any properties.

2.7.1.1.1.1.1.2.21 RowCount Component

The **RowCount Component** MUST NOT use any **Name** attribute value on a **property** element except for those that are listed in the table in this section.

The following table specifies the **Name** attribute values that are allowed for the RowCount Component, in addition to any restrictions on the element value. These restrictions MUST be followed.

Name attribute value	Description
VariableName	The property element value MUST be a string value. This value specifies the name of the variable that holds the row count.

2.7.1.1.1.1.1.2.22 Row Sampling Component

The **Row Sampling Component** MUST NOT use any **Name** attribute value on a **property** element except for those that are listed in the table in this section.

The following table specifies the **Name** attribute values that are allowed for the Row Sampling Component, in addition to any restrictions on the element value. These restrictions MUST be followed.

Name attribute value	Description
SamplingValue	The property element MUST be an integer. This value specifies the number of rows in the sample.
SamplingSeed	The property element MUST be an integer. This value specifies the seed value for the random number generator.

2.7.1.1.1.1.1.2.23 Script Component

The **Script Component** MUST NOT use any **Name** attribute value on a **property** element except for those that are listed in the table in this section.

The following table specifies the **Name** attribute values that are allowed for the Script Component, in addition to any restrictions on the element value. These restrictions MUST be followed.

Name attribute value	Description
SourceCode	The property element value MUST be empty. The SourceCode property element MUST contain the arrayElements element. The value specifies the source code for the Script Component.
BinaryCode	The property element value MUST be empty. The BinaryCode property element MUST contain the arrayElements element. The value specifies the binary code for the Script Component.
VSTAProjectName	The property element value MUST be a string value. This value specifies the project name for the Script Component. <38>
ScriptLanguage	The property element value MUST be a string value from an enumeration. This value specifies the language of the script project. The valid string values are as follows: "CSsharp" – The C# language. "VisualBasic" – The Visual Basic language.
ReadOnlyVariables	The property element value MUST be a string value. This value specifies the read-only variables in the package that are available to the Script Component.
ReadWriteVariables	The property element value MUST be a string value. This value specifies

Name attribute value	Description
	the read-write variables in the package that are available to the Script Component.
BreakpointCollection	The property element value MUST be empty. The BreakpointCollection property element MUST contain the arrayElements element. The value specifies a collection of breakpoints for the Script Component.
UserComponentTypeName	The property element value MUST be a string value. This value specifies the fully qualified assembly name for the component.

2.7.1.1.1.1.1.2.24 Slowly Changing Dimension Component

The **Slowly Changing Dimension Component** MUST NOT use any **Name** attribute value on a **property** element except for those that are listed in the table in this section.

The following table specifies the **Name** attribute values that are allowed for the Slowly Changing Dimension Component, in addition to any restrictions on the element value. These restrictions MUST be followed.

Name attribute value	Description
SqlCommand	The property element value MUST be a string value. This value specifies an SQL statement that is used to create a schema rowset.
CurrentRowWhere	The property element value MUST be a string value. This value specifies a WHERE clause of an SQL SELECT statement that selects the current row among the rows that have the same key value.
UpdateChangingAttributeHistory	The property element value MUST be a Boolean. This value specifies whether historical attribute updates are directed to the transformation output for changing attribute updates.
FailOnFixedAttributeChange	The property element value MUST be a Boolean. This value specifies whether the transformation fails when rows where the columns with fixed attributes contain changes or when the lookup in the dimension table fails. TRUE specifies that when fixed attributes change or the lookup fails, the operation fails. FALSE specifies that when fixed attributes change or the lookup fails, the operation identifies a new record.
InferredMemberIndicator	The property element value MUST be a string value. This value specifies the column name for the inferred member .
EnableInferredMember	The property element value MUST be a Boolean. The value specifies whether inferred member updates are detected. TRUE specifies that inferred member updates are detected. FALSE specifies that inferred member updates are not detected.
FailOnLookupFailure	The property element value MUST be a Boolean. The value specifies whether lookup failure results in task failure. TRUE specifies that a lookup failure results in a task failure. FALSE specifies that a lookup failure does not result in a task failure.

Name attribute value	Description
IncomingRowChangeType	The property element value MUST be an integer between 0 and 1. This enumeration value specifies the incoming row change type. The allowed values are as follows: 0 – All incoming rows are considered to be new rows. 1 – The system detects which incoming rows are new.
DefaultCodePage	The property element value MUST be an integer. This value specifies the default code page to use if code page information is not available from the data source.

2.7.1.1.1.1.1.2.25 Sort Component

The **Sort Component** MUST NOT use any **Name** attribute value on a **property** element except for those that are listed in the table in this section.

The following table specifies the **Name** attribute values that are allowed for the Sort Component, in addition to any restrictions on the element value. These restrictions MUST be followed.

Name attribute value	Description
EliminateDuplicates	The property element value MUST be a Boolean. The value specifies whether to removed duplicate rows from the output. TRUE specifies that duplicate rows are removed from the output. FALSE specifies that duplicate rows are not removed from the output.
MaximumThreads	The property element value MUST be an integer. The value specifies the maximum number of threads to use for sorting. <39>

2.7.1.1.1.1.1.2.26 Term Extraction Component

The Term Extraction Component MUST NOT use any **Name** attribute value on a **property** element except for those that are listed in the table in this section.

The following table specifies the **Name** attribute values that are allowed for the Term Extraction Component, in addition to any restrictions on the element value. These restrictions MUST be followed.

Name attribute value	Description
NeedReferenceData	The property element value MUST be a Boolean. This value specifies whether a table of excluded terms is used. TRUE specifies that a table of excluded terms is used. FALSE specifies that a table of excluded terms is not used.
OutTermTable	The property element value MUST be a string value. This value specifies the table name that contains the excluded terms.
OutTermColumn	The property element value MUST be a string value. This value specifies the column name that contains the excluded terms.

Name attribute value	Description
WordOrPhrase	The property element value MUST be an integer between 0 and 2. This enumeration value specifies how terms are determined. The valid enumeration values are as follows: 0 – Words only. 1 – Noun phrases only. 2 – Words and noun phrases.
ScoreType	The property element value MUST be an integer between 0 and 1. This value specifies what type of score is associated with the term. 0 – The frequency of the term is its score. 1 – The TFIDF score is the term's score.
FrequencyThreshold	The property element value MUST be an integer. This value specifies the number of occurrences of a term before it is extracted.
MaxLengthOfTerm	The property element value MUST be an integer. This value specifies the maximum length of terms in characters. It applies only to phrases.
IsCaseSensitive	The property element value MUST be a Boolean. This value specifies whether case sensitivity is used when detecting nouns and noun phrases. TRUE specifies that case is used when detecting nouns and noun phrases. FALSE specifies that case is ignored when detecting nouns and noun phrases.

2.7.1.1.1.1.1.2.27 Term Lookup Component

The **Term Lookup Component** MUST NOT use any **Name** attribute value on a **property** element except for those that are listed in the table in this section.

The following table specifies the **Name** attribute values that are allowed for the Term Lookup Component, in addition to any restrictions on the element value. These restrictions MUST be followed.

Name attribute value	Description
RefTermTable	The property element value MUST be a string value. This value specifies the name of the table that contains the reference terms.
RefTermColumn	The property element value MUST be a string value. This value specifies the name of the column that contains the reference terms.
IsCaseSensitive	The property element value MUST be a Boolean. This value specifies whether case sensitivity is applied to matching input terms with reference terms. TRUE specifies that case is used when matching input terms with reference terms. FALSE specifies that case is ignored when matching input terms with reference terms.

2.7.1.1.1.1.1.2.28 Union All Component

The **Union All Component** MUST NOT have any properties.

2.7.1.1.1.1.1.2.29 Unpivot Component

The **Unpivot Component** MUST NOT have any properties.

2.7.1.1.1.1.1.2.30 ADO.NET Destination Component

The ADO.NET Destination Component MUST NOT use any **Name** attribute value on a **property** element except for those that are listed in the table in this section.

The following table specifies the **Name** attribute values that are allowed for the ADO.NET Destination Component, in addition to any restrictions on the element value. These restrictions MUST be followed.

Name attribute value	Description
TableOrViewName	The property element value MUST be a string value. This value specifies the name of the table or view for the task.
BatchSize	The property element value MUST be an integer. This value specifies the number of rows that are sent to the server at a time. <40>
CommandTimeout	The property element value MUST be an integer. This value specifies the number of seconds that elapse before the command times out. <41>
UserComponentTypeName	The property element value MUST be a string value. This value specifies the fully qualified Microsoft® .NET Framework assembly name for the component.

2.7.1.1.1.1.1.2.31 Excel Destination Component

The Excel Destination Component MUST NOT use any **Name** attribute value on a **property** element except for those that are listed in the table in this section.

The following table specifies the **Name** attribute values that are allowed for the Excel Destination Component, in addition to any restrictions on the element value. These restrictions MUST be followed.

Name attribute value	Description
CommandTimeout	The property element value MUST be an integer. This value specifies the number of seconds that elapse before the command times out. <42>
OpenRowset	The property element value MUST be a string value. This value specifies the name of the table or view that is used. This value is used when the AccessMode attribute is set to the value "0" or "3".
OpenRowsetVariable	The property element value MUST be a string value. This value specifies the name of the variable that contains the name of the table or view that is used. This value is used when the AccessMode attribute is set to the value "1" or "4".
SqlCommand	The property element value MUST be a string value. This value specifies the SQL command that is used. It is used when the AccessMode attribute is set to value "2".
AccessMode	The property element value MUST be an integer value between 0 and

Name attribute value	Description
	<p>5. This enumeration value specifies how to access the database at its destination. The allowed values have the following meanings:</p> <p>0 – The name of a table or view is user-specified.</p> <p>1 – The name of a variable that contains the name of a table or view is specified.</p> <p>2 – A user-specified SQL statement is used.</p> <p>3 – Open the rowset with a fast load operation or with a specified table name or view name.</p> <p>4 – Open the rowset with a fast load operation or with the table name or view name specified in a variable.</p>
FastLoadKeepIdentity	<p>The property element value MUST be a Boolean. This value specifies whether to copy identity values during a fast load operation. This value is used if the AccessMode attribute is set to the value "3" or "4".</p> <p>TRUE specifies that identity values are copied.</p> <p>FALSE specifies that identity values are not copied.</p>
FastLoadKeepNulls	<p>The property element value MUST be a Boolean. This value specifies whether to copy NULL values during a fast load operation. This value is used if the AccessMode attribute is set to the value "3" or "4".</p> <p>TRUE specifies that NULL values should be copied.</p> <p>FALSE specifies that NULL values should not be copied.</p>
FastLoadOptions	<p>The property element value MUST be a string value. This value specifies the fast load options that are selected. The string is a comma-separated list of fast load options. For more information about fast load options, see [MSDN-PBCO].<43></p>
FastLoadMaxInsertCommitSize	<p>The property element value MUST be an integer. The value specifies the commit size, in rows, that is used when the AccessMode attribute is set to value "3" or "4".</p>

2.7.1.1.1.1.1.2.32 Flat File Destination Component

The **Flat File Destination Component** MUST NOT use any **Name** attribute value on a **property** element except for those that are listed in the table in this section.

The following table specifies the **Name** attribute values that are allowed for the Flat File Destination Component, in addition to any restrictions on the element value. These restrictions MUST be followed.

Name attribute value	Description
Header	<p>The property element value MUST be a string value. This value contains a string that is inserted into the file header before data is written to the file.</p>
Overwrite	<p>The property element value MUST be a Boolean. This value specifies whether to overwrite or to append to an existing destination file with the same name.</p> <p>TRUE specifies to overwrite a destination file with the same name.</p> <p>FALSE specifies to append to a destination file with the same name.</p>

2.7.1.1.1.1.1.2.33 OLE DB Destination Component

The **OLE DB Destination Component** MUST NOT use any **Name** attribute value on a **property** element except for those that are listed in the table in this section.

The following table specifies the **Name** attribute values that are allowed for the OLE DB Destination Component, in addition to any restrictions on the element value. These restrictions MUST be followed.

Name attribute value	Description
CommandTimeout	The property element value MUST be an integer. This value specifies the number of seconds that elapse before the command times out. <44>
OpenRowset	The property element value MUST be a string value. This value specifies the name of the table or view that is used. This value is used when the AccessMode attribute is set to the value "0" or "3".
OpenRowsetVariable	The property element value MUST be a string value. This value specifies the name of the variable that contains the name of the table or view that is used. This value is used when the AccessMode attribute is set to the value "1" or "4".
SqlCommand	The property element value MUST be a string value. This value specifies the SQL command that is used. This value is used when the AccessMode attribute is set to value "2".
DefaultCodePage	The property element value MUST be an integer. This value specifies the default code page to use if code page information is not available from the data source.
AlwaysUseDefaultCodePage	The property element value MUST be a Boolean. This value specifies whether to always use the value for the code page given in the DefaultCodePage attribute. TRUE specifies to always use the value that is given in the DefaultCodePage attribute for the code page value. FALSE specifies to first try to derive the code page value from the data source. If the code page value cannot be derived from the data source, the DefaultCodePage attribute value is used.
AccessMode	The property element value MUST be an integer value between 0 and 5. This enumeration value specifies how to access the database at its destination. The allowed values have the following meanings: 0 – The name of a table or view is user-specified. 1 – The name of a variable that contains the name of a table or view is specified. 2 – A user-specified SQL statement is used. 3 – The rowset is opened by using a fast load operation, with a specified table name or view name. 4 – The rowset is opened by using a fast load operation, with the table name or view name that is specified in a variable.
FastLoadKeepIdentity	The property element value MUST be a Boolean. This value specifies whether to copy identity values during a fast load operation. This value is used if the AccessMode attribute is set to the value "3" or "4".

Name attribute value	Description
	TRUE specifies that identity values are copied. FALSE specifies that identity values are not copied.
FastLoadKeepNulls	The property element value MUST be a Boolean. This value specifies whether to copy NULL values during a fast load operation. This value is used if the AccessMode attribute is set to the value "3" or "4". TRUE specifies that NULL values should be copied. FALSE specifies that NULL values should not be copied.
FastLoadOptions	The property element value MUST be a string value. This value specifies the fast load options that are selected. The string is a comma-separated list of fast load options. For more information about fast load options, see [MSDN-PBCO].<45>
FastLoadMaxInsertCommitSize	The property element value MUST be an integer. The value specifies the commit size, in rows, that is used when AccessMode is set to value "3" or "4".

2.7.1.1.1.1.1.2.34 DataReader Destination Component

The **DataReader Destination Component** MUST NOT use any **Name** attribute value on a **property** element except for those that are listed in the table in this section.

The following table specifies the **Name** attribute values that are allowed for the DataReader Destination Component, in addition to any restrictions on the element value. These restrictions MUST be followed.

Name attribute value	Description
ReadTimeout	The property element value MUST be an integer. This value specifies the number of milliseconds that elapse before the operation times out.
DataReader	The property element value MUST be a string value. This value specifies the class name of the data reader object at the destination.
FailOnTimeout	The property element value MUST be a Boolean. This value specifies whether to fail if the value for the ReadTimeout attribute is reached. TRUE specifies to fail if the ReadTimeout attribute value is reached. FALSE specifies not to fail if the ReadTimeout attribute value is reached.
UserComponentTypeName	The property element value MUST be a string value. This value specifies the fully qualified Microsoft® .NET Framework assembly name for the component.

2.7.1.1.1.1.1.2.35 Data Mining Model Training Destination Component

The **Data Mining Model Training Destination Component** MUST NOT use any **Name** attribute value on a **property** element except for those that are listed in the table in this section.

The following table specifies the **Name** attribute values that are allowed for the Data Mining Model Training Destination Component, in addition to any restrictions on the element value. These restrictions MUST be followed.

Name attribute value	Description
ObjectRef	The property element value MUST be a string value. This value specifies an XML tag that identifies the mining structure that the task uses.

2.7.1.1.1.1.1.2.36 Dimension Processing Destination Component

The **Dimension Processing Destination Component** MUST NOT use any **Name** attribute value on a **property** element except for those that are listed in the table in this section.

The following table specifies the **Name** attribute values that are allowed for the Dimension Processing Destination Component, in addition to any restrictions on the element value. These restrictions MUST be followed.

Name attribute value	Description
ObjectRef	The property element value MUST be a string value. This value contains a reference to an Analysis Management Objects (AMO) object that represents the dimension after it is looked up. <46>
UseDefaultConfiguration	The property element value MUST be a Boolean. This value specifies whether to use the existing default configuration on the server. TRUE specifies to use the existing default configuration on the server. FALSE specifies to not use the default configuration on the server. If the value is FALSE, the value that is used is specified in the values of the properties of the component.
KeyErrorLimit	The property element value MUST be an integer. This value specifies the number of key errors after which processing fails. This value is used only if the UseDefaultConfiguration attribute value is set to FALSE.
KeyErrorLogFile	The property element value MUST be a string value. This value specifies the file path to the file that is used to log key errors. This value is used only if the UseDefaultConfiguration attribute value is set to FALSE.
KeyErrorAction	The property element value MUST be an integer value between 0 and 1. The enumeration value specifies the action to take upon encountering a key processing error. The allowed values are the following: 0 – Convert the key to the “unknown” value. 1 – Discard the record. This value is used only if the UseDefaultConfiguration attribute value is set to FALSE.
KeyErrorLimitAction	The property element value MUST be an integer value between 0 and 1. This enumeration value specifies the action to take upon reaching the key error limit. The allowed values are the following: 0 – Stop processing. 1 – Continue processing and stop logging. This value is used only if the UseDefaultConfiguration attribute value is set to FALSE.

Name attribute value	Description
KeyNotFound	<p>The property element value MUST be an integer between 0 and 2. This value specifies the action to take if a key is not found. The allowed values are the following:</p> <ul style="list-style-type: none"> 0 – Ignore the error. 1 – Report the error and continue. 2 – Report the error and stop processing. <p>This value is used only if the UseDefaultConfiguration attribute value is set to FALSE.</p>
KeyDuplicate	<p>The property element value MUST be an integer between 0 and 2. This value specifies the action to take if a duplicate key is found. The allowed values are the following:</p> <ul style="list-style-type: none"> 0 – Ignore the error. 1 – Report the error and continue. 2 – Report the error and stop processing. <p>This value is used only if the UseDefaultConfiguration attribute value is set to FALSE.</p>
NullKeyConvertedToUnknown	<p>The property element value MUST be an integer between 0 and 2. This value specifies the action to take if a null key is found and converted to “unknown”. The allowed values are the following:</p> <ul style="list-style-type: none"> 0 – Ignore the error. 1 – Report the error and continue. 2 – Report the error and stop processing. <p>This value is used only if the UseDefaultConfiguration attribute value is set to FALSE.</p>
NullKeyNotAllowed	<p>The property element value MUST be an integer between 0 and 2. This value specifies the action to take if a null key is found that is not allowed. The allowed values are the following:</p> <ul style="list-style-type: none"> 0 – Ignore the error. 1 – Report the error and continue. 2 – Report the error and stop processing. <p>This value is used only if the UseDefaultConfiguration attribute value is set to FALSE.</p>
ProcessType	<p>The property element value MUST be an integer between 0 and 2. This value specifies the type of processing that is performed on the dimension. The allowed values are the following:</p> <ul style="list-style-type: none"> 0 – Full processing. 1 – Processing to add to dimension. 2 – Update processing. <p>For more information about Microsoft® SQL Server® Analysis Services processing types, see [MSDN-POS].</p>

2.7.1.1.1.1.1.2.37 Partition Processing Destination Component

The **Partition Processing Destination Component** MUST NOT use any **Name** attribute value on a **property** element except for those that are listed in the table in this section.

The following table specifies the **Name** attribute values that are allowed for the Partition Processing Destination Component, in addition to any restrictions on the element value. These restrictions MUST be followed.

Name attribute value	Description
ObjectRef	The property element value MUST be a string value. This value contains a reference to an Analysis Management Objects (AMO) object that represents the partition after it is looked up.<47>
UseDefaultConfiguration	The property element value MUST be a Boolean. This value specifies whether to use the existing default configuration on the server. TRUE specifies to use the existing default configuration on the server. FALSE specifies to not use the default configuration on the server. If the value is FALSE, the values that are used are specified in the values of the properties of the component.
KeyErrorLimit	The property element value MUST be an integer. This value specifies the number of key errors after which processing fails. This value is used only if the UseDefaultConfiguration attribute value is set to FALSE.
KeyErrorLogFile	The property element value MUST be a string value. This value specifies the file path to the file that is used to log key errors. This value is used only if the UseDefaultConfiguration attribute value is set to FALSE.
KeyErrorAction	The property element value MUST be an integer value between 0 and 1. The enumeration value specifies the action to take upon encountering a key processing error. The allowed values are the following: 0 – Convert the key to the “unknown” value. 1 – Discard the record. This value is used only if the UseDefaultConfiguration attribute value is set to FALSE.
KeyErrorLimitAction	The property element value MUST be an integer value between 0 and 1. This enumeration value specifies the action to take upon reaching the key error limit. The allowed values are the following: 0 – Stop processing. 1 – Continue processing and stop logging. This value is used only if the UseDefaultConfiguration attribute value is set to FALSE.
KeyNotFound	The property element value MUST be an integer between 0 and 2. This value specifies the action to take if a key is not found. The allowed values are the following: 0 – Ignore the error. 1 – Report the error and continue. 2 – Report the error and stop processing. This value is used only if the UseDefaultConfiguration attribute value is set to FALSE.
KeyDuplicate	The property element value MUST be an integer between 0 and 2. This value specifies the action to take if a duplicate key is found. The

Name attribute value	Description
	<p>allowed values are the following:</p> <ul style="list-style-type: none"> 0 – Ignore the error. 1 – Report the error and continue. 2 – Report the error and stop processing. <p>This value is used only if the UseDefaultConfiguration attribute value is set to FALSE.</p>
NullKeyConvertedToUnknown	<p>The property element value MUST be an integer between 0 and 2. This value specifies the action to take if a null key is found and converted to “unknown”. The allowed values are the following:</p> <ul style="list-style-type: none"> 0 – Ignore the error. 1 – Report the error and continue. 2 – Report the error and stop processing. <p>This value is used only if the UseDefaultConfiguration attribute value is set to FALSE.</p>
NullKeyNotAllowed	<p>The property element value MUST be an integer between 0 and 2. This value specifies the action to take if a null key is found that is not allowed. The allowed values are the following:</p> <ul style="list-style-type: none"> 0 – Ignore the error. 1 – Report the error and continue. 2 – Report the error and stop processing. <p>This value is used only if the UseDefaultConfiguration attribute value is set to FALSE.</p>
ProcessType	<p>The property element value MUST be an integer between 0 and 2. This value specifies the type of processing that is performed on the dimension. The allowed values are the following:</p> <ul style="list-style-type: none"> 0 – Full processing. 1 – Processing to add to dimension. 2 – Update processing. <p>For more information about Microsoft® SQL Server® Analysis Services processing types, see [MSDN-POS].</p>

2.7.1.1.1.1.1.2.38 Raw File Destination Component

The **Raw File Destination Component** MUST NOT use any **Name** attribute value on a **property** element except for those that are listed in the table in this section.

The following table specifies the **Name** attribute values that are allowed for the Raw File Destination Component, in addition to any restrictions on the element value. These restrictions MUST be followed.

Name attribute value	Description
AccessMode	<p>The property element value MUST be an integer between 0 and 1. This enumeration value specifies whether the file name is specified in the XML or is specified as the value of a variable. The allowed values are the following:</p> <ul style="list-style-type: none"> 0 – The file name is specified in the XML.

Name attribute value	Description
	1 – The file name is specified as the value of a variable.
FileName	The property element value MUST be a string value. This value specifies the name of the file for output. This value is used only if the value of the AccessMode attribute is "0".
FileNameVariable	The property element value MUST be a string value. The value specifies the name of the variable that contains the file name for the output file. This value applies only if the value for the AccessMode attribute is equal to "1".
WriteOption	The property element value MUST be an integer between 0 and 3. This value specifies the action to take for the file write operation. The allowed values are the following: 0 – Always create the file. 1 – Create the file one time only. 2 – Append to an existing file. 3 – Truncate the file and append.

2.7.1.1.1.1.1.2.39 RecordSet Destination Component

The **RecordSet Destination Component** MUST NOT use any **Name** attribute value on a **property** element except for those that are listed in the table in this section.

The following table specifies the **Name** attribute values that are allowed for the RecordSet Destination Component, in addition to any restrictions on the element value. These restrictions MUST be followed.

Name attribute value	Description
VariableName	The property element value MUST be a string value. This value specifies the name of the variable that holds the ADO recordset.

2.7.1.1.1.1.1.2.40 SQL Server Compact Edition Destination Component

The **SQL Server Compact Edition Destination Component** MUST NOT use any **Name** attribute value on a **property** element except for those that are listed in the table in this section.

The following table specifies the **Name** attribute values that are allowed for the SQL Server Compact Edition Destination Component, in addition to any restrictions on the element value. These restrictions MUST be followed.

Name attribute value	Description
TableName	The property element value MUST be a string value. This value specifies the name of the destination table in the SQL Server Compact edition database.
UserComponentTypeName	The property element value MUST be a string value. This value specifies the fully qualified Microsoft® .NET Framework assembly name for the component.

2.7.1.1.1.1.1.2.41 SQL Server Destination Component

The **SQL Server Destination Component** MUST NOT use any **Name** attribute value on a **property** element except for those that are listed in the table in this section.

The following table specifies the **Name** attribute values that are allowed for the SQL Server Destination Component, in addition to any restrictions on the element value. These restrictions MUST be followed.

Name attribute value	Description
DefaultCodePage	The property element value MUST be an integer. This value specifies the default code page to use if code page information is not available from the data source.
AlwaysUseDefaultCodePage	The property element value MUST be a Boolean. This value specifies whether to always use the value for the code page that is given in the DefaultCodePage attribute. TRUE specifies to always use the value that is given in the DefaultCodePage attribute for the code page value. FALSE specifies to first try to derive the code page value from the data source. If the code page value cannot be derived from the data source, the DefaultCodePage attribute value is used.
BulkInsertTableName	The property element value MUST be a string value. This value specifies the table name to use for the bulk insert operation.
BulkInsertCheckConstraints	The property element value MUST be a Boolean. This enumeration value specifies whether constraints on the table are checked during the bulk insert operation. TRUE specifies that constraints are checked. FALSE specifies that constraints are not checked.
BulkInsertFirstRow	The property element value MUST be an integer. This value specifies the row in the table at which insertion begins. <48>
BulkInsertFireTriggers	The property element value MUST be a Boolean. This value specifies whether insert triggers that are specified for the table are fired during the bulk insert operation. TRUE specifies that triggers are fired during the bulk insert operation. FALSE specifies that triggers are not fired during the bulk insert operation.
BulkInsertKeepIdentity	The property element value MUST be a Boolean. This value specifies whether to keep data values from the data file for values for identity columns. TRUE specifies that the values that are present in the data file are kept for identity columns. FALSE specifies that the values that are present in the data file for identity columns are not kept.
BulkInsertKeepNulls	The property element value MUST be a Boolean. This value specifies whether null values in the input are retained. TRUE specifies that null values in the input are retained. FALSE specifies that a default value is used if a null value is encountered in the input.

Name attribute value	Description
BulkInsertLastRow	The property element value MUST be an integer. This value specifies the row in the data file at which insertion ends. <49>
BulkInsertMaximumErrors	The property element value MUST be an integer. This enumeration value specifies the maximum number of errors that are allowed.
BulkInsertOrder	The property element value MUST be a string value. This value specifies the columns that are used for sorting.
BulkInsertTablock	The property element value MUST be a Boolean. This value specifies whether a table level lock is acquired for the bulk insert operation. TRUE specifies that a table level lock is acquired for the bulk insert operation. FALSE specifies that a table level lock is not acquired for the bulk insert operation.
Timeout	The property element value MUST be an integer. This value specifies the number of seconds that the destination waits for records to insert before the operation times out. <50>
MaxInsertCommitSize	The property element value MUST be an integer. This value specifies the maximum number of rows to insert in a single batch. <51>

2.7.1.1.1.1.1.2.42 ADO.NET Source Component

The **ADO.NET Source Component** MUST NOT use any **Name** attribute value on a **property** element except for those that are listed in the table in this section.

The following table specifies the **Name** attribute values that are allowed for the ADO.Net Source Component, in addition to any restrictions on the element value. These restrictions MUST be followed.

Name attribute value	Description
SqlCommand	The property element value MUST be a string value. This value specifies an SQL SELECT command string that populates the lookup table.
CommandTimeout	The property element value MUST be an integer. This value specifies the number of seconds before the command times out. <52>
AllowImplicitStringConversion	The property element value MUST be a Boolean. The value specifies whether external metadata types are converted to the type that the destination requires. <53> TRUE specifies that external types are converted to strings. FALSE specifies that no error is generated if there is a mismatch between the external metadata type and a column that requires a string.
TableOrViewName	The property element value MUST be a string value. This value specifies the name of the table or view for the task.
AccessMode	The property element value MUST be an integer from an enumeration (the value "0" or "2"). This value specifies the access mode to the ADO.NET data. The allowed values are the following:

Name attribute value	Description
	0 – Table or view. 2 – SQL command.
UserComponentTypeName	The property element value MUST be a string value. This value specifies the fully qualified Microsoft® .NET Framework assembly name for the component.

2.7.1.1.1.1.1.2.43 Excel Source Component

The **Excel Source Component** MUST NOT use any **Name** attribute value on a **property** element except for those that are listed in the table in this section.

The following table specifies the **Name** attribute values that are allowed for the Excel Source Component, in addition to any restrictions on the element value. These restrictions MUST be followed.

Name attribute value	Description
CommandTimeout	The property element value MUST be an integer. This value specifies the number of seconds that elapse before the command times out. <54>
OpenRowset	The property element value MUST be a string value. This value specifies the name of the table or view that is used. This value is used when the AccessMode attribute is set to the value "0" or "3".
OpenRowsetVariable	The property element value MUST be a string value. This value specifies the name of the variable that contains the name of the table or view that is used. This value is used when the AccessMode attribute is set to the value "1" or "4".
SqlCommand	The property element value MUST be a string value. This value specifies the SQL command that is used. This value is used when the AccessMode attribute is set to the value "2".
SqlCommandVariable	The property element value MUST be a string value. This value specifies the name of the variable that contains the SQL command that is executed.
AccessMode	The property element value MUST be an integer value between 0 and 4. This enumeration value specifies how to access the data in the Microsoft® Office Excel® sheet. The allowed values have the following meanings: 0 – Use "open rowset" to open the Office Excel data. 1 – Use "open rowset" from the value that is contained in a variable. 2 – Use an SQL command to open the Office Excel data. 3 – Use an SQL command that is contained in a variable to open the Office Excel data.
ParameterMapping	The property element value MUST be a string value. This value specifies the mapping of SQL parameters to values that are contained in variables.

2.7.1.1.1.1.1.2.44 Flat File Source Component

The **Flat File Source Component** MUST NOT use any **Name** attribute value on a **property** element except for those that are listed in the table in this section.

The following table specifies the **Name** attribute values that are allowed for the Flat File Source Component, in addition to any restrictions on the element value. These restrictions **MUST** be followed.

Name attribute value	Description
RetainNulls	The property element value MUST be a Boolean value. This value specifies whether to retain NULL values that are obtained from the source during the pipeline processing. TRUE specifies that NULL values are retained during pipeline processing. FALSE specifies that NULL values are not retained.
FileNameColumnName	The property element value MUST be a string value. This value specifies the name of the output column that contains the file name for the flat file source file.

2.7.1.1.1.1.1.2.45 OLE DB Source Component

The **OLE DB Source Component** **MUST NOT** use any **Name** attribute value on a **property** element except for those that are listed in the table in this section.

The following table specifies the **Name** attribute values that are allowed for the OLE DB Source Component, in addition to any restrictions on the element value. These restrictions **MUST** be followed.

Name attribute value	Description
CommandTimeout	The property element value MUST be an integer. This value specifies the number of seconds that elapse before the command times out. <55>
OpenRowset	The property element value MUST be a string value. This value specifies the name of the table or view that is used. This value is used when the AccessMode attribute is set to the value "0" or "3".
OpenRowsetVariable	The property element value MUST be a string value. This value specifies the name of the variable that contains the name of the table or view that is used. This value is used when the AccessMode attribute is set to the value "1" or "4".
SqlCommand	The property element value MUST be a string value. This value specifies the SQL command that is used. This value is used when the AccessMode attribute is set to value "2".
DefaultCodePage	The property element value MUST be an integer. This value specifies the default code page to use if code page information is not available from the data source.
AlwaysUseDefaultCodePage	The property element value MUST be a Boolean. This value specifies whether to always use the value for the code page given in the DefaultCodePage attribute. TRUE specifies to always use the value given in the DefaultCodePage attribute for the code page value. FALSE specifies to first try to derive the code page value from the data source. If the code page value cannot be derived from the data source, the DefaultCodePage attribute value is used.

Name attribute value	Description
AccessMode	The property element value MUST be an integer value between 0 and 4. This enumeration value specifies how to access the data in the Microsoft® Office Excel® sheet. The allowed values have the following meanings. 0 – Use “open rowset” to open the Office Excel data. 1 – Use “open rowset” from the value that is contained in a variable. 2 – Use an SQL command to open the Office Excel data. 3 – Use an SQL command that is contained in a variable to open the Office Excel data.
ParameterMapping	The property element value MUST be a string value. This value specifies the mapping of SQL parameters to values that are contained in variables.

2.7.1.1.1.1.1.2.46 Raw File Source Component

The Raw File Source Component MUST NOT use any **Name** attribute value on a **property** element except for those that are listed in the table in this section.

The following table specifies the **Name** attribute values that are allowed for the Raw File Source Component, in addition to any restrictions on the element value. These restrictions MUST be followed.

Name attribute value	Description
AccessMode	The property element value MUST be an integer between 0 and 1. This enumeration value specifies whether the file is specified in the XML or is specified as the value of a variable. The allowed values are the following: 0 – The file name is specified in the package file. 1 – The file name is specified as the value of a variable.
FileName	The property element value MUST be a string value. This value specifies the name of the file for output. This value is used only if the value of the AccessMode attribute is “0”.
FileNameVariable	The property element value MUST be a string value. The value specifies the name of the variable that contains the file name for the output file. This value applies only if the value for the AccessMode attribute is equal to “1”.

2.7.1.1.1.1.1.2.47 XML Source Component

The **XML Source Component** MUST NOT use any **Name** attribute value on a **property** element except for those that are listed in the table in this section.

The following table specifies the **Name** attribute values that are allowed for the XML Source Component, in addition to any restrictions on the element value. These restrictions MUST be followed.

Name attribute value	Description
UserComponentTypeName	The property element value MUST be a string value. This value specifies

Name attribute value	Description
	the fully qualified Microsoft® .NET Framework assembly name for the component.
XMLData	The property element value MUST be a string value. This value specifies the file name or variable name that contains the XML. The content of the string is dependent upon the value of the AccessMode attribute.
XMLDataVariable	The property element value MUST be a string value. This value specifies the name of the variable that contains the XML data.
AccessMode	The property element value MUST be an integer between 0 and 2. This value specifies the mode of access of the XML. The allowed values are the following. 0 - XML file. 1 - XML file from the value of a variable. 2 - XML data from the value of a variable.
XMLSchemaDefinition	The property element value MUST be a string value. The value contains an inline XML Schema definition. This value is used if the UseInlineSchema attribute value is set to TRUE.
UseInlineSchema	The property element value MUST be a Boolean. The value specifies whether an inline XML Schema definition is used. TRUE specifies that an inline XML Schema definition is used. FALSE specifies that an inline XML Schema definition is not used.

2.7.1.1.1.1.1.3 PipelineComponentDataTypeEnum

The **PipelineComponentDataTypeEnum** type contains the enumeration values for the **dataType** attribute.

The following is the XSD for the **PipelineComponentDataTypeEnum** type.

```
<xs:simpleType name="PipelineComponentDataTypeEnum">
  <xs:restriction base="xs:string">
    <xs:enumeration value="System.Boolean"/>
    <xs:enumeration value="System.Byte"/>
    <xs:enumeration value="System.SByte"/>
    <xs:enumeration value="System.Decimal"/>
    <xs:enumeration value="System.Double"/>
    <xs:enumeration value="System.Single"/>
    <xs:enumeration value="System.Int32"/>
    <xs:enumeration value="System.UInt32"/>
    <xs:enumeration value="System.Int64"/>
    <xs:enumeration value="System.UInt64"/>
    <xs:enumeration value="System.Int16"/>
    <xs:enumeration value="System.UInt16"/>
    <xs:enumeration value="System.String"/>
    <xs:enumeration value="System.Null"/>
    <xs:enumeration value="System.DateTime"/>
    <xs:enumeration value="System.Object"/>
  </xs:restriction>
</xs:simpleType>
```

The following table specifies the enumeration values for the **PipelineComponentDataTypeEnum** type.

Enumeration value	Description
System.Boolean	The value is a Boolean.
System.Byte	The value is a byte.
System.SByte	The value is an 8-bit signed integer.
System.Decimal	The value is a decimal quantity.
System.Double	The value is a double precision real number.
System.Single	The value is a single precision real number.
System.Int32	The value is a 32-bit integer.
System.UInt32	The value is a 32-bit unsigned integer.
System.Int64	The value is a 64-bit integer.
System.UInt64	The value is a 64-bit unsigned integer.
System.Int16	The value is a 16-bit integer.
System.UInt16	The value is a 16-bit unsigned integer.
System.String	The value is a string.
System.Null	The value is null.
System.DateTime	The value is a date/time value.
System.Object	The value is an object.

2.7.1.1.1.1.1.1.4 PipelineComponentStateEnum

The **PipelineComponentStateEnum** type contains the enumeration values for the **state** attribute.

The following is the XSD for the **PipelineComponentStateEnum** type.

```
<xs:simpleType name="PipelineComponentStateEnum">
  <xs:restriction base="xs:string">
    <xs:enumeration value="cdata"/>
    <xs:enumeration value="escaped"/>
    <xs:enumeration value="default"/>
  </xs:restriction>
</xs:simpleType>
```

The following table specifies the enumeration values for the **PipelineComponentStateEnum** type.

Enumeration value	Description
cdata	Serialize the property value as a CDATA XSD section.

Enumeration value	Description
escaped	Serialize the property value as text, with escape sequence as needed.
default	Serialize the property value in the default fashion.

2.7.1.1.1.1.1.5 PipelineComponentExpressionTypeEnum

The **PipelineComponentExpressionTypeEnum** type contains the enumeration values for the **expressionType** attribute.

The following is the XSD for the **PipelineComponentExpressionTypeEnum** type.

```
<xs:simpleType name="PipelineComponentExpressionTypeEnum">
  <xs:restriction base="xs:string">
    <xs:enumeration value="None"/>
    <xs:enumeration value="Notify"/>
  </xs:restriction>
</xs:simpleType>
```

The following table specifies the enumeration values for the **PipelineComponentExpressionTypeEnum** type.

Enumeration value	Description
None	The value of the property cannot be specified with an expression.
Notify	The value of the property can be specified with a property expression.

2.7.1.1.1.1.2 PipelineComponentConnectionsType

The **PipelineComponentConnectionsType** complex type specifies a collection of connection objects for a component.

The following is the XSD for the **PipelineComponentConnectionsType** complex type.

```
<xs:complexType name="PipelineComponentConnectionsType">
  <xs:sequence>
    <xs:element name="connection" form="unqualified"
      type="DTS:PipelineComponentConnectionType"
      minOccurs="0" maxOccurs="unbounded"/>
  </xs:sequence>
</xs:complexType>
```

The following table specifies the elements of the **PipelineComponentConnectionsType** complex type.

Element	Type definition	Description
connection	PipelineComponentConnectionType	A complex type that specifies a reference to a connection manager that is available to this

Element	Type definition	Description
		component.

2.7.1.1.1.2.1 PipelineComponentConnectionType

The **PipelineComponentConnectionType** complex type specifies a collection of connection objects for a component.

The following is the XSD for the **PipelineComponentConnectionType** complex type.

```
<xs:complexType name="PipelineComponentConnectionType">
  <xs:sequence/>
  <xs:attribute name="refId" type="xs:string" use="required"
    form="unqualified"/>
  <xs:attribute name="name" type="xs:string" use="optional"
    default="" form="unqualified"/>
  <xs:attribute name="description" type="xs:string"
    use="optional" default="" form="unqualified"/>
  <xs:attribute name="connectionManagerID" type="xs:string"
    use="optional" default="" form="unqualified"/>
</xs:complexType>
```

The following table specifies the attributes of the **PipelineComponentConnectionType** complex type.

Attribute	Description
refId	A string value that specifies a unique refId for this object. Elsewhere within the containing executable or within the package, the value of refId can be used to refer to this object. <56>
name	A string value that specifies the name for this component connection element.
description	A string value that specifies the description for this component connection element.
connectionManagerID	A universally unique identifier (UUID) value that specifies the DTSID attribute of the connection manager that is used by this component connection.

2.7.1.1.1.3 PipelineComponentInputsType

The **PipelineComponentInputsType** complex type specifies a collection of output objects for a component.

The following is the XSD for the **PipelineComponentInputsType** complex type.

```
<xs:complexType name="PipelineComponentInputsType">
  <xs:sequence>
    <xs:element name="input" form="unqualified"
      type="DTS:PipelineComponentInputType"
      minOccurs="0" maxOccurs="unbounded"/>
  </xs:sequence>
```

```
</xs:complexType>
```

The following table specifies the elements of the **PipelineComponentInputsType** complex type.

Element	Type definition	Description
input	PipelineComponentInputType	A complex type that specifies a reference to an input that is available to this component.

2.7.1.1.1.1.3.1 PipelineComponentInputType

The **PipelineComponentInputType** complex type specifies the structure in which the descriptor for a single input to a component is held. All inputs are not identical, so this general structure is designed to hold the variety of inputs that a component can have.

The following is the XSD for the **PipelineComponentInputType** complex type.

```
<xs:complexType name="PipelineComponentInputType">
  <xs:sequence>
    <xs:element name="inputColumns"
      type="DTS:PipelineComponentInputColumnsType"
      minOccurs="0" form="unqualified"/>
    <xs:element name="externalMetadataColumns"
      type="DTS:PipelineComponentMetadataColumnsType"
      minOccurs="0" form="unqualified"/>
  </xs:sequence>
  <xs:attributeGroup
    ref="DTS:PipelineComponentInputOutputElementAttributeGroup"/>
</xs:complexType>
```

The following table specifies the elements of the **PipelineComponentInputType** complex type.

Element	Type definition	Description
inputColumns	PipelineComponentInputColumnsType	A complex type that specifies a collection of input columns that are associated with the input element.
externalMetadataColumns	PipelineComponentMetadataColumnsType	A complex type that specifies a collection of external metadata columns that are associated with the input element.

The following table specifies the attribute groups of the **PipelineComponentInputType** complex type.

Attribute	Description
PipelineComponentInputOutputElementAttributeGroup	An attribute group specification that specifies attributes that are common for the input element and for the output element of the

Attribute	Description
	PipelineComponentInputType type.

2.7.1.1.1.3.1.1 PipelineComponentInputColumnsType

The **PipelineComponentInputColumnsType** complex type specifies a collection of column objects for an **input** element that is part of a Pipeline component.

The following is the XSD for the **PipelineComponentInputColumnsType** complex type.

```
<xs:complexType name="PipelineComponentInputColumnsType">
  <xs:sequence>
    <xs:element name="inputColumn"
      type="DTS:PipelineComponentInputColumnType"
      minOccurs="0" maxOccurs="unbounded" form="unqualified"/>
  </xs:sequence>
</xs:complexType>
```

The following table specifies the elements of the **PipelineComponentInputColumnsType** complex type.

Element	Type definition	Description
inputColumn	PipelineComponentInputColumnType	A complex type that specifies a single column within a pipeline input.

2.7.1.1.1.3.1.2 PipelineComponentInputColumnType

The **PipelineComponentInputColumnType** complex type specifies a single column that is a member of a collection of input columns to a Pipeline component.

The following is the XSD for the **PipelineComponentInputColumnType** complex type.

```
<xs:complexType name="PipelineComponentInputColumnType">
  <xs:sequence>
    <xs:element name="properties"
      type="DTS:PipelineComponentInputColumnPropertiesType"
      form="unqualified" minOccurs="0" maxOccurs="unbounded"/>
  </xs:sequence>
  <xs:attributeGroup
    ref="DTS:PipelineComponentAllColumnBaseAttributeGroup"/>
  <xs:attributeGroup
    ref="DTS:PipelineComponentIOColumnBaseAttributeGroup"/>
  <xs:attribute name="usageType" form="unqualified"
    use="optional" default="readOnly"
    type="DTS:PipelineComponentUsageTypeEnum"/>
  <xs:attribute name="cachedName" type="xs:string"
    use="optional" default="" form="unqualified"/>
  <xs:attribute name="cachedSortKeyPosition" type="xs:int"
    use="optional" default="0" form="unqualified"/>
  <xs:attribute name="cachedPrecision" type="xs:int" use="optional"
    default="0" form="unqualified"/>
</xs:complexType>
```

```

<xs:attribute name="cachedScale" type="xs:int" use="optional"
  default="0" form="unqualified"/>
<xs:attribute name="cachedLength" type="xs:int" use="optional"
  default="0" form="unqualified"/>
<xs:attribute name="cachedDataType"
  type="DTS:PipelineComponentColumnDataTypeEnum"
  use="optional" default="empty" form="unqualified"/>
<xs:attribute name="cachedCodepage" type="xs:int" use="optional"
  default="0" form="unqualified"/>
<xs:attribute name="cachedComparisonFlags" type="xs:int"
  form="unqualified" use="optional" default="0" />
</xs:complexType>

```

The following table specifies the elements of the **PipelineComponentInputColumnType** complex type.

Element	Type definition	Description
properties	PipelineComponentPropertiesType	A complex type that specifies a collection of properties of an input column.

The following table specifies the attributes and attribute groups of the **PipelineComponentInputColumnType** complex type.

Attribute group	Description
PipelineComponentAllColumnBaseAttributeGroup	An attribute group specification that specifies attributes that are common to all types of columns for Pipeline components.
PipelineComponentIOColumnBaseAttributeGroup	An attribute group specification that specifies attributes that are common to all input and output columns for Pipeline components.
usageType	An enumeration value that specifies the type of use available for the input column.
cachedName	A string value that specifies the name for this column element.
cachedSortKeyPosition	An integer value that specifies the position of this column among the sort keys.
cachedPrecision	An integer value that specifies the total digits in a numeric data type.
cachedScale	An integer value that specifies the number of digits to the right of the decimal point.
cachedLength	An integer value that specifies the length of the column in characters.
cachedDataType	An enumeration value that specifies the type of the data in the column.
cachedCodepage	An integer value that specifies the numeric value of the ANSI code page that is used for strings for this column.

Attribute group	Description
cachedComparisonFlags	<p>An integer value that is a bitmask that specifies which options are chosen for comparison of values in the column. The interpretation of the bits in this integer is as follows:</p> <ul style="list-style-type: none"> 0x00000001 – Ignore case. 0x00000002 – Ignore nonspace characters. 0x00000004 – Ignore symbols. 0x00000010 – Linguistically appropriate ignore case. 0x00000020 – Linguistically appropriate ignore nonspace characters. 0x00010000 – Ignore Kana type. 0x00020000 – Ignore width. 0x08000000 – Use linguistic rules for casing.

2.7.1.1.1.3.1.3 PipelineComponentInputColumnPropertiesType

The **PipelineComponentInputColumnPropertiesType** complex type specifies a collection of properties for an **inputColumn** element that is part of a Pipeline component.

The following is the XSD for the **PipelineComponentInputColumnPropertiesType** complex type.

```
<xs:complexType name="PipelineComponentInputColumnPropertiesType">
  <xs:sequence>
    <xs:element name="property" form="unqualified"
      type="DTS:PipelineComponentInputColumnPropertyType"
      minOccurs="0" maxOccurs="unbounded"/>
  </xs:sequence>
</xs:complexType>
```

The following table specifies the elements of the **PipelineComponentInputColumnPropertiesType** complex type.

Element	Type definition	Description
property	PipelineComponentInputColumnPropertyType	A complex type that specifies a single property within a collection of input column properties for an inputColumn element of a Pipeline component.

2.7.1.1.1.3.1.3.1 PipelineComponentInputColumnPropertyType

The **PipelineComponentInputColumnPropertyType** complex type specifies a property of an **inputColumn** element.

The following is the XSD for the **PipelineComponentInputColumnPropertyType** complex type.

```
<xs:complexType name="PipelineComponentInputColumnPropertyType">
  <xs:simpleContent>
    <xs:extension base="xs:anySimpleType">
```

```

    <xs:attributeGroup
      ref="DTS:PipelineComponentPropertyAttributeGroup"/>
    <xs:attribute name="name" form="unqualified" use="required"
      type="DTS:PipelineComponentInputColumnPropertyNameEnum"/>
  </xs:extension>
</xs:simpleContent>
</xs:complexType>

```

The following table specifies the attributes and attribute groups of the **PipelineComponentInputColumnPropertyType** complex type.

Attribute	Description
PipelineComponentPropertyAttributeGroup	An attribute group that contains attributes that are common to all property elements for input elements, output elements, inputColumn elements, and outputColumn elements.
name	A string value that specifies the name of the property.

2.7.1.1.1.3.1.3.1.1 PipelineComponentInputColumnPropertyNameEnum

The **PipelineComponentInputColumnPropertyNameEnum** type contains the allowed values for the **name** attribute on the **inputColumn** element of a Pipeline component. The allowed values for the property element for each task are more restricted than the values that are specified formally by the XSD.

Each **name** attribute value MUST NOT be used for any component except for the components that are specified in the subsections to this section. Some components allow no properties.

The additional restrictions specified in the subsections to this section MUST be followed for the **name** attribute on the **property** element children of the **inputColumn** element.

The following is the XSD for the **PipelineComponentInputColumnPropertyNameEnum** type.

```

<xs:simpleType name="PipelineComponentInputColumnPropertyNameEnum">
  <xs:restriction base="xs:string">
    <!--Transforms-->
    <!--Aggregate Task-->
    <!--Audit (none)-->
    <!--Cache Transform-->
    <xs:enumeration value="CacheColumnName"/>
    <!--Character Map-->
    <xs:enumeration value="MapFlags"/>
    <!--Conditional Split (none)-->
    <!--Copy Column (none)-->
    <!--Data Conversion (none)-->
    <!--Data Mining Query(none)-->
    <!--Derived Column Query-->
    <xs:enumeration value="Expression"/>
    <xs:enumeration value="FriendlyExpression"/>
    <!--Export Column-->
    <xs:enumeration value="FileDataColumnID"/>
    <xs:enumeration value="WriteBOM"/>
    <xs:enumeration value="ForceTruncate"/>
  </xs:restriction>
</xs:simpleType>

```

```

<xs:enumeration value="AllowAppend"/>
<!--Fuzzy Grouping, Fuzzy Lookup-->
<xs:enumeration value="ToBeCleaned"/>
<xs:enumeration value="ExactFuzzy"/>
<xs:enumeration value="LeadingTrailingNumeralsSignificant"/>
<xs:enumeration value="MinSimilarity"/>
<xs:enumeration value="FuzzyComparisonFlags"/>
<!--Import Column-->
<xs:enumeration value="FileDataColumnID"/>
<xs:enumeration value="ExpectBOM"/>
<!--Lookup-->
<xs:enumeration value="JoinToReferenceColumn"/>
<xs:enumeration value="CopyFromReferenceColumn"/>
<!--Merge-->
<xs:enumeration value="OutputColumnLineageID"/>
<!--MergeJoin (none)-->
<!--Multicast (none)-->
<!--OLE DB Command (none)-->
<!--Percentage Sampling (none)-->
<!--Pivot-->
<xs:enumeration value="PivotUsage"/>
<!--RowCount (none)-->
<!--Row Sampling (none)-->
<!--Script Component (none)-->
<!--Slowly Changing Dimension-->
<xs:enumeration value="ColumnType"/>
<!--Sort-->
<xs:enumeration value="NewComparisonFlags"/>
<xs:enumeration value="NewSortKeyPosition"/>
<!--Term Extraction (none)-->
<!--Term Lookup-->
<xs:enumeration value="InputColumnType"/>
<!--UnionAll-->
<xs:enumeration value="OutputColumnLineageID"/>
<!--Unpivot-->
<xs:enumeration value="DestinationColumn"/>
<xs:enumeration value="PivotKeyValue"/>
<!--Data Destinations-->
<!--ADO.Net Destination (none)-->
<!--Excel Destination (none)-->
<!--Flat File Destination (none)-->
<!--OLE DB Destination (none)-->
<!--Raw File Destination (none)-->
<!--DataReader Destination (none)-->
<!--Data Mining Model Training (none)-->
<!--Dimension Processing (none)-->
<!--Partition Processing (none)-->
<!--RecordSet Destination (none)-->
<!--SQL Server Compact Destination (none)-->
<!--SQL Server Destination (none)-->
</xs:restriction>
</xs:simpleType>

```

2.7.1.1.1.3.1.3.1.1.1 Aggregate Component inputColumn Element

The Aggregate Component MUST NOT have any properties on the **inputColumn** element.

2.7.1.1.1.3.1.3.1.1.2 Audit Component inputColumn Element

The Audit Component MUST NOT have any properties on the **inputColumn** element.

2.7.1.1.1.3.1.3.1.1.3 Cache Component inputColumn Element

The **Cache Component inputColumn** element MUST NOT use any **Name** attribute value on a **property** element except for those that are listed in the table in this section.

The following table specifies the **Name** attribute values that are allowed for the Cache Component on the **inputColumn** element, in addition to any restrictions on the element value. These restrictions MUST be followed.

Name attribute value	Description
CacheColumnName	The property element value MUST be a string value. This value specifies the name of a column that is associated with an input column.

2.7.1.1.1.3.1.3.1.1.4 Character Map Component inputColumn Element

The Character Map Component **inputColumn** element MUST NOT use any **Name** attribute value on a **property** element except for those that are listed in the table in this section.

The following table specifies the **Name** attribute values that are allowed for the Character Map Component on the **inputColumn** element, in addition to any restrictions on the element value. These restrictions MUST be followed.

Name attribute value	Description
MapFlags	The property element value MUST be an integer value between 0 and 9. This enumeration value specifies the string operation that is performed on the column. The allowed values are the following: 0 – Map to lower case. 1 – Map to upper case. 2 – Perform byte reversal. 3 – Map to Hiragana. 4 – Map to Katakana. 5 – Map to half width. 6 – Map to full width. 7 – Perform linguistic casing. 8 – Map to Simplified Chinese. 9 – Map to Traditional Chinese.

2.7.1.1.1.3.1.3.1.1.5 Conditional Split Component inputColumn Element

The Conditional Split Component MUST NOT have any properties on the **inputColumn** element.

2.7.1.1.1.3.1.3.1.1.6 Copy Column Component inputColumn Element

The Copy Column Component MUST NOT have any properties on the **inputColumn** element.

2.7.1.1.1.1.3.1.3.1.1.7 Data Conversion Component inputColumn Element

The Data Conversion Component MUST NOT have any properties on the **inputColumn** element.

2.7.1.1.1.1.3.1.3.1.1.8 Data Mining Query Component inputColumn Element

The Data Mining Query Component MUST NOT have any properties on the **inputColumn** element.

2.7.1.1.1.1.3.1.3.1.1.9 Derived Column Component inputColumn Element

The Derived Column Component **inputColumn** element MUST NOT use any **Name** attribute value on a **property** element except for those that are listed in the table in this section.

The following table specifies the **Name** attribute values that are allowed for the Derived Column Component on the **inputColumn** element, in addition to any restrictions on the element value. These restrictions MUST be followed.

Name attribute value	Description
Expression	The property element value MUST be a string value. This value specifies the expression by which the column is derived.
FriendlyExpression	The property element value MUST be a string value. This value specifies a conditional expression by which the column is derived. The FriendlyExpression attribute uses column names in the expression syntax, while the Expression attribute uses only column LineageIDs.

2.7.1.1.1.1.3.1.3.1.1.10 Export Column Component inputColumn Element

The Export Column Component **inputColumn** element MUST NOT use any **Name** attribute value on a **property** element except for those that are listed in the table in this section.

The following table specifies the **Name** attribute values that are allowed for the Export Column Component on the **inputColumn** element, in addition to any restrictions on the element value. These restrictions MUST be followed.

Name attribute value	Description
FileDataColumnID	The property element value MUST be an integer. This value specifies the identifier for the column that contains the data that is inserted by the task.
WriteBOM	The property element value MUST be a Boolean. This value specifies whether a byte order mark (BOM) is inserted into the file. TRUE specifies that a BOM is inserted into the file. FALSE specifies that a BOM is not inserted into the file.
ForceTruncate	The property element value MUST be a Boolean. This value specifies whether a truncation is forced before a write operation on an existing file. TRUE specifies that a truncation is forced before a write operation on an existing file. FALSE specifies that a truncation is not forced before a write operation on an existing file.

Name attribute value	Description
AllowAppend	<p>The property element value MUST be a Boolean. This value specifies whether the transformation is allowed to append data to an existing file.</p> <p>TRUE specifies that the transformation is allowed to append data to an existing file.</p> <p>FALSE specifies that the transformation is not allowed to append data to an existing file.</p>

2.7.1.1.1.1.3.1.3.1.1.11 Fuzzy Grouping Component inputColumn Element

The Fuzzy Grouping Component **inputColumn** element MUST NOT use any **Name** attribute value on a **property** element except for those that are listed in the table in this section.

The following table specifies the **Name** attribute values that are allowed for the Fuzzy Grouping Component on the **inputColumn** element, in addition to any restrictions on the element value. These restrictions MUST be followed.

Name attribute value	Description
ToBeCleaned	<p>The property element value MUST be a Boolean. This value specifies whether this is a column to be grouped by.</p> <p>TRUE specifies that this is a column to be grouped by.</p> <p>FALSE specifies that this is not a column to be grouped by.</p>
ExactFuzzy	<p>The property element value MUST be an integer between 1 and 2. This value specifies whether the fuzzy match is exact or fuzzy. The allowed values are the following:</p> <p>1 – Exact.</p> <p>2 – Fuzzy.</p>
LeadingTrailingNumeralsSignificant	<p>The property element value MUST be an integer between 0 and 3. This enumeration value specifies how to treat numerals. The allowed values are as follows:</p> <p>0 – Numerals are not significant.</p> <p>1 – Leading numerals are significant.</p> <p>2 – Trailing numerals are significant.</p> <p>3 – Both leading and trailing numerals are significant.</p>
MinSimilarity	<p>The property element value MUST be a double precision value between 0 and 1. This value specifies the similarity threshold to join on the column. Only rows that are greater than this value qualify as matches.</p>
FuzzyComparisonFlags	<p>The property element value MUST be an integer value. This integer value is a bitmask that specifies the comparison flags for the sort operation. The bit values are as follows:</p> <p>0x00000001 - Ignore case.</p> <p>0x00000002 - Ignore nonspace characters.</p> <p>0x00000004 - Ignore symbols.</p> <p>0x00000100 - Sort punctuation as symbols.</p> <p>0x00001000 - Ignore Kana type.</p>

Name attribute value	Description
	0x00002000 - Ignore character width.

2.7.1.1.1.1.3.1.3.1.1.12 Fuzzy Lookup Component inputColumn Element

The Fuzzy Lookup Component **inputColumn** element MUST NOT use any **Name** attribute value on a **property** element except for those that are listed in the table in this section.

The following table specifies the **Name** attribute values that are allowed for the Fuzzy Lookup Component on the **inputColumn** element, in addition to any restrictions on the element value. These restrictions MUST be followed.

Name attribute value	Description
ToBeCleaned	The property element value MUST be a Boolean. This value specifies whether this is a column to be grouped by. TRUE specifies that this is a column to be grouped by. FALSE specifies that this is not a column to be grouped by.
ExactFuzzy	The property element value MUST be an integer between 1 and 2. This value specifies whether the fuzzy match is exact or fuzzy. The allowed values are the following: 1 - Exact 2 - Fuzzy
LeadingTrailingNumeralsSignificant	The property element value MUST be an integer between 0 and 3. This enumeration value specifies how to treat numerals. The allowed values are as follows: 0 - Numerals are not significant. 1 - Leading numerals are significant. 2 - Trailing numerals are significant. 3 - Both leading and trailing numerals are significant.
MinSimilarity	The property element value MUST be a double precision value between 0 and 1. This value specifies the similarity threshold to join on the column. Only rows that are greater than this value qualify as matches.
FuzzyComparisonFlags	The property element value MUST be an integer value. This integer value is a bitmask that specifies the comparison flags for the sort operation. The bit values are as follows: 0x00000001 - Ignore case. 0x00000002 - Ignore nonspace characters. 0x00000004 - Ignore symbols. 0x00000100 - Sort punctuation as symbols. 0x00001000 - Ignore Kana type. 0x00002000 - Ignore character width.

2.7.1.1.1.1.3.1.3.1.1.13 Import Column Component inputColumn Element

The Import Column Component **inputColumn** element MUST NOT use any **Name** attribute value on a **property** element except for those that are listed in the table in this section.

The following table specifies the **Name** attribute values that are allowed for the Import Column Component on the **inputColumn** element, in addition to any restrictions on the element value. These restrictions **MUST** be followed.

Name attribute value	Description
FileDataColumnID	The property element value MUST be an integer. This value specifies the identifier for the column that contains the data that is inserted into the data flow.
ExpectBOM	The property element value MUST be a Boolean. This value specifies whether a byte order mark (BOM) is expected in the column. TRUE specifies that a BOM is expected in the column. FALSE specifies that a BOM is not expected in the column.

2.7.1.1.1.3.1.3.1.1.14 Lookup Component inputColumn Element

The Lookup Component **inputColumn** element **MUST NOT** use any **Name** attribute value on a **property** element except for those that are listed in the table in this section.

The following table specifies the **Name** attribute values that are allowed for the Lookup Component on the **inputColumn** element, in addition to any restrictions on the element value. These restrictions **MUST** be followed.

Name attribute value	Description
JoinToReferenceColumn	The property element value MUST be a string. This value specifies the name of the column in the reference table upon which to join.
CopyFromReferenceColumn	The property element value MUST be a string. This value specifies the name of the column in the reference table from which a column is copied.

2.7.1.1.1.3.1.3.1.1.15 Merge Component inputColumn Element

The Merge Component **MUST NOT** have any properties on the **inputColumn** element.

2.7.1.1.1.3.1.3.1.1.16 MergeJoin Component inputColumn Element

The MergeJoin Component **MUST NOT** have any properties on the **inputColumn** element.

2.7.1.1.1.3.1.3.1.1.17 Multicast Component inputColumn Element

The Multicast Component **MUST NOT** have any properties on the **inputColumn** element.

2.7.1.1.1.3.1.3.1.1.18 OLE DB Command Component inputColumn Element

The OLE DB Command Component **MUST NOT** have any properties on the **inputColumn** element.

2.7.1.1.1.3.1.3.1.1.19 Percentage Sampling Component inputColumn Element

The Percentage Sampling Component **MUST NOT** have any properties on the **inputColumn** element.

2.7.1.1.1.3.1.3.1.1.20 Pivot Component inputColumn Element

The Pivot Component **inputColumn** element MUST NOT use any **Name** attribute value on a **property** element except for those that are listed in the table in this section.

The following table specifies the **Name** attribute values that are allowed for the Pivot Component on the **inputColumn** element, in addition to any restrictions on the element value. These restrictions MUST be followed.

Name attribute value	Description
PivotUsage	The property element value MUST be an integer value between 0 and 3. This value specifies the role of a column for pivoting. The allowed values are the following: 0 – The column is not pivoted. 1 – The column provides row keys. All input rows with the same value are combined into one output row. 2 – The column is a pivot column. At least one column is created for each value in this column. 3 – The values from this column are placed in one of the cells created by the pivot.

2.7.1.1.1.3.1.3.1.1.21 RowCount Component inputColumn Element

The RowCount Component MUST NOT have any properties on the **inputColumn** element.

2.7.1.1.1.3.1.3.1.1.22 Row Sampling Component inputColumn Element

The Row Sampling Component MUST NOT have any properties on the **inputColumn** element.

2.7.1.1.1.3.1.3.1.1.23 Script Component inputColumn Element

The Script Component MUST NOT have any properties on the **inputColumn** element.

2.7.1.1.1.3.1.3.1.1.24 Slowly Changing Dimension Component inputColumn Element

The Slowly Changing Dimension Component **inputColumn** element MUST NOT use any **Name** attribute value on a **property** element except for those that are listed in the table in this section.

The following table specifies the **Name** attribute values that are allowed for the Slowly Changing Dimension Component on the **inputColumn** element, in addition to any restrictions on the element value. These restrictions MUST be followed.

Name attribute value	Description
ColumnType	The property element value MUST be an integer value between 0 and 4. This value specifies the update type for the column. 0 – Unknown. 1 – Key column. 2 – Changing attribute. 3 – Historical attribute. 4 – Fixed attribute.

2.7.1.1.1.3.1.3.1.1.25 Sort Component inputColumn Element

The Sort Component **inputColumn** element MUST NOT use any **Name** attribute value on a **property** element except for those that are listed in the table in this section.

The following table specifies the **Name** attribute values that are allowed for the Sort Component on the **inputColumn** element, in addition to any restrictions on the element value. These restrictions MUST be followed.

Name attribute value	Description
NewComparisonFlags	The property element value MUST be an integer value. This integer value is a bitmask that specifies the comparison flags for the sort operation. The bit values are as follows: 0x00000001 - Ignore case. 0x00000002 - Ignore nonspace characters. 0x00000004 - Ignore symbols. 0x00000100 - Sort punctuation as symbols. 0x00001000 - Ignore Kana type. 0x00002000 - Ignore character width.
NewSortKeyPosition	The property element value MUST be an integer. This value specifies the sort order of the column.

2.7.1.1.1.3.1.3.1.1.26 Term Extraction Component inputColumn Element

The **Term Extraction Component** MUST NOT have any properties on the **inputColumn** element.

2.7.1.1.1.3.1.3.1.1.27 Term Lookup Component inputColumn Element

The Term Lookup Component **inputColumn** element MUST NOT use any **Name** attribute value on a **property** element except for those that are listed in the table in this section.

The following table specifies the **Name** attribute values that are allowed for the Term Lookup Component on the **inputColumn** element, in addition to any restrictions on the element value. These restrictions MUST be followed.

Name attribute value	Description
InputColumnType	The property element value MUST be an integer between 0 and 2. This value specifies the input column type. The allowed values are the following: 0 - Passthrough column. 1 - Lookup column. 2 - Passthrough and lookup column.

2.7.1.1.1.3.1.3.1.1.28 Union All Component inputColumn Element

The Union All Component **inputColumn** element MUST NOT use any **Name** attribute value on a **property** element except for those that are listed in the table in this section.

The following table specifies the **Name** attribute values that are allowed for the Union All Component on the **inputColumn** element, in addition to any restrictions on the element value. These restrictions **MUST** be followed.

Name attribute value	Description
OutputColumnLineageID	The property element value MUST be an integer. This value specifies the LineageID of the corresponding output column.

2.7.1.1.1.3.1.3.1.1.29 Unpivot Component inputColumn Element

The Unpivot Component **inputColumn** element **MUST NOT** use any **Name** attribute value on a **property** element except for those that are listed in the table in this section.

The following table specifies the **Name** attribute values that are allowed for the Unpivot Component on the **inputColumn** element, in addition to any restrictions on the element value. These restrictions **MUST** be followed.

Name attribute value	Description
DestinationColumn	The property element value MUST be an integer. This value specifies the LineageID of the corresponding output column. <57>
PivotKeyValue	The property element value MUST be a string value. This value specifies one of the pivot key values that is copied to an output column.

2.7.1.1.1.3.1.3.1.1.30 ADO.NET Destination Component inputColumn Element

The **ADO.NET Destination Component** **MUST NOT** have any properties on the **inputColumn** element.

2.7.1.1.1.3.1.3.1.1.31 Excel Destination Component inputColumn Element

The **Excel Destination Component** **MUST NOT** have any properties on the **inputColumn** element.

2.7.1.1.1.3.1.3.1.1.32 Flat File Destination Component inputColumn Element

The Flat File Destination Component **MUST NOT** have any properties on the **inputColumn** element.

2.7.1.1.1.3.1.3.1.1.33 OLE DB Destination Component inputColumn Element

The OLE DB Destination Component **MUST NOT** have any properties on the **inputColumn** element.

2.7.1.1.1.3.1.3.1.1.34 DataReader Destination Component inputColumn Element

The DataReader Destination Component **MUST NOT** have any properties on the **inputColumn** element.

2.7.1.1.1.3.1.3.1.1.35 Data Mining Model Training Destination Component inputColumn Element

The Data Mining Model Training Destination Component **MUST NOT** have any properties on the **inputColumn** element.

2.7.1.1.1.3.1.3.1.1.36 Dimension Processing Destination Component **inputColumn** Element

The Dimension Processing Destination Component MUST NOT have any properties on the **inputColumn** element.

2.7.1.1.1.3.1.3.1.1.37 Partition Processing Destination Component **inputColumn** Element

The Partition Processing Destination Component MUST NOT have any properties on the **inputColumn** element.

2.7.1.1.1.3.1.3.1.1.38 Raw File Destination Component **inputColumn** Element

The Raw File Destination Component MUST NOT have any properties on the **inputColumn** element.

2.7.1.1.1.3.1.3.1.1.39 RecordSet Destination Component **inputColumn** Element

The RecordSet Destination Component MUST NOT have any properties on the **inputColumn** element.

2.7.1.1.1.3.1.3.1.1.40 SQL Server Compact Edition Destination Component **inputColumn** Element

The SQL Server Compact Edition Destination Component MUST NOT have any properties on the **inputColumn** element.

2.7.1.1.1.3.1.3.1.1.41 SQL Server Destination Component **inputColumn** Element

The SQL Server Destination Component MUST NOT have any properties on the **inputColumn** element.

2.7.1.1.1.3.1.3.2 PipelineComponentUsageTypeEnum

The **PipelineComponentUsageTypeEnum** type contains the enumeration values for the **usageType** attribute.

The following is the XSD for the **PipelineComponentUsageTypeEnum** type.

```
<xs:simpleType name="PipelineComponentUsageTypeEnum">
  <xs:restriction base="xs:string">
    <xs:enumeration value="readOnly"/>
    <xs:enumeration value="readWrite"/>
    <xs:enumeration value="Ignored"/>
  </xs:restriction>
</xs:simpleType>
```

The following table specifies the enumeration values for the **PipelineComponentUsageTypeEnum** type.

Enumeration value	Description
readOnly	The column is read-only.

Enumeration value	Description
readWrite	The column is available for read operations and for write operations.
Ignored	The column is ignored.

2.7.1.1.1.3.1.4 PipelineComponentInputPropertiesType

The **PipelineComponentInputPropertiesType** complex type specifies a collection of properties for an **input** element that is part of a Pipeline component.

The following is the XSD for the **PipelineComponentInputPropertiesType** complex type.

```
<xs:complexType name="PipelineComponentInputPropertiesType">
  <xs:sequence>
    <xs:element name="property" form="unqualified"
      type="DTS:PipelineComponentInputPropertyType"
      minOccurs="0" maxOccurs="unbounded"/>
  </xs:sequence>
</xs:complexType>
```

The following table specifies the elements of the **PipelineComponentInputPropertiesType** complex type.

Element	Type definition	Description
property	PipelineComponentInputPropertyType	A complex type that specifies a single property within a collection of input properties for an input element of a Pipeline component.

2.7.1.1.1.3.1.5 PipelineComponentInputPropertyType

The **PipelineComponentInputPropertyType** complex type specifies the structure in which the value for a single property of an input of a component is held. All inputs do not use the same set of properties, so this general structure is designed to hold the variety of properties that an input can have.

The following is the XSD for the **PipelineComponentInputPropertyType** complex type.

```
<xs:complexType name="PipelineComponentInputPropertyType"
  mixed="true">
  <xs:sequence>
    <xs:element name="arrayElements"
      type="DTS:PipelineComponentArrayElementsType"
      form="unqualified" minOccurs="0"/>
  </xs:sequence>
  <xs:attributeGroup
    ref="DTS:PipelineComponentPropertyAttributeGroup"/>
  <xs:attribute name="name" use="required"
    type="DTS:PipelineComponentInputPropertyNameEnum"
    form="unqualified"/>
</xs:complexType>
```

The following table specifies the elements of the **PipelineComponentInputPropertyType** complex type.

Element	Type definition	Description
arrayElements	PipelineComponentArrayElementsType	A complex type that contains a collection of elements that form an array. The collection constitutes the value for the property. This element is used only if the value of the isArray attribute is TRUE.

The following table specifies the attribute groups and the attributes of the **PipelineComponentInputPropertyType** complex type.

Attribute	Description
PipelineComponentPropertyAttributeGroup	An attribute group that contains attributes that are common to all property elements for input elements, output elements, inputColumn elements, and outputColumn elements.
name	A string value that specifies the name of the property.

2.7.1.1.1.3.1.6 PipelineComponentInputPropertyNameEnum

The **PipelineComponentPropertyNameEnum** type contains the allowed values for the **name** attribute on the **input** element of a Pipeline component. The allowed values for the **property** element for each task are more restricted than the values that are specified formally by the XSD.

No tasks allow any property elements on the **input** element. Therefore, the **PipelineComponentInputPropertyNameEnum** type does not contain any enumerated values. It is specified as a type as the **property** element itself is valid, and custom components can add valid property names for the name attribute. For more information about the addition of properties by custom programmers, see [Custom Packages](#).

All tasks MUST NOT have any properties on the **input** element.

The following is the XSD for the **PipelineComponentInputPropertyNameEnum** type.

```
<xs:simpleType name="PipelineComponentInputPropertyNameEnum">
  <xs:restriction base="xs:string">
    </xs:restriction>
  <!--None of the components have properties for the Input element-->
</xs:simpleType>
```

2.7.1.1.1.4 PipelineComponentOutputsType

The **PipelineComponentOutputsType** complex type specifies a collection of output objects for a component.

The following is the XSD for the **PipelineComponentOutputsType** complex type.

```
<xs:complexType name="PipelineComponentOutputsType">
```



```

<xs:sequence>
  <xs:element name="output" form="unqualified"
    type="DTS:PipelineComponentOutputType"
    minOccurs="0" maxOccurs="unbounded"/>
</xs:sequence>
</xs:complexType>

```

The following table specifies the elements of the **PipelineComponentOutputsType** complex type.

Element	Type definition	Description
output	PipelineComponentOutputType	A complex type that specifies a reference to an output that is created by this component and that is available to other components.

2.7.1.1.1.4.1 PipelineComponentOutputType

The **PipelineComponentOutputType** complex type specifies the structure in which the descriptor for a single output from a component is held. All outputs are not identical, so this general structure is designed to hold the variety of outputs that a component can have.

The following is the XSD for the **PipelineComponentOutputType** complex type.

```

<xs:complexType name="PipelineComponentOutputType">
  <xs:sequence>
    <xs:element name="properties"
      type="DTS:PipelineComponentOutputPropertiesType"
      minOccurs="0" form="unqualified"/>
    <xs:element name="outputColumns"
      type="DTS:PipelineComponentOutputColumnsType"
      minOccurs="0" form="unqualified"/>
    <xs:element name="externalMetadataColumns"
      type="DTS:PipelineComponentMetadataColumnsType"
      minOccurs="0" form="unqualified"/>
  </xs:sequence>
  <xs:attributeGroup
    ref="DTS:PipelineComponentInputOutputElementAttributeGroup"/>
  <xs:attribute name="exclusionGroup" type="xs:int"
    use="optional" default="0" form="unqualified"/>
  <xs:attribute name="synchronousInputId" type="xs:string"
    use="optional" default="0" form="unqualified"/>
  <xs:attribute name="deleteOutputOnPathDetached" type="xs:boolean"
    use="optional" default="false" form="unqualified"/>
  <xs:attribute name="isErrorOut" type="xs:boolean"
    use="optional" default="false" form="unqualified"/>
  <xs:attribute name="isSorted" type="xs:boolean" use="optional"
    default="false" form="unqualified"/>
</xs:complexType>

```

The following table specifies the elements of the **PipelineComponentOutputType** complex type.

Element	Type definition	Description
properties	PipelineComponentPropertiesType	A complex type that specifies

Element	Type definition	Description
		a collection of properties that are associated with the output element.
outputColumns	PipelineComponentOutputColumnsType	A complex type that specifies a collection of output columns that are associated with the output element.
externalMetadataColumns	PipelineComponentMetadataColumnType	A complex type that specifies a collection of external metadata columns that are associated with the output element.

The following table specifies the attribute groups and the attributes of the **PipelineComponentPropertyType** complex type.

Attribute	Description
PipelineComponentInputOutputElementAttributeGroup	An attribute group specification that specifies attributes that are common for the input element and for the output element of the PipelineComponentOutputType type.
exclusionGroup	An integer value that specifies a hint to the data flow engine about whether copies of flowing data may need to be made for multiple outputs. If multiple outputs share the same exclusionGroup value, the engine guarantees that input rows are output to only one of those outputs. If the exclusionGroup value is "0" or if the exclusionGroup attribute for outputs is unequal, no such guarantee is made.
synchronousInputId	An integer value that specifies the id attribute of an input that is synchronous with this output.
deleteOutputOnPathDetached	A Boolean value that determines whether the data flow engine deletes the output when it is detached from a path. TRUE specifies that the output is deleted when it is detached from a path. FALSE specifies that the output is not deleted when it is detached from a path.
isErrorOut	A Boolean value that specifies whether the output is an error output. TRUE specifies that the output is an error output. FALSE specifies that the output is not an error output.
isSorted	A Boolean value that specifies whether the output is sorted. TRUE specifies that the output is sorted.

Attribute	Description
	FALSE specifies that the output is not sorted.

2.7.1.1.1.4.1.1 PipelineComponentOutputColumnsType

The **PipelineComponentOutputColumnsType** complex type specifies a collection of column objects for an **output** element that is part of a Pipeline component.

The following is the XSD for the **PipelineComponentOutputColumnsType** complex type.

```
<xs:complexType name="PipelineComponentOutputColumnsType">
  <xs:sequence>
    <xs:element name="outputColumn"
      type="DTS:PipelineComponentOutputColumnType"
      minOccurs="0" maxOccurs="unbounded" form="unqualified"/>
  </xs:sequence>
</xs:complexType>
```

The following table specifies the elements of the **PipelineComponentOutputColumnsType** complex type.

Element	Type definition	Description
outputColumn	PipelineComponentOutputColumnType	A complex type that specifies a single column within a collection of output columns for a Pipeline component.

2.7.1.1.1.4.1.1.1 PipelineComponentOutputColumnType

The **PipelineComponentOutputColumnType** complex type specifies a single column that is a member of a collection of output columns in a Pipeline component.

The following is the XSD for the **PipelineComponentOutputColumnType** complex type.

```
<xs:complexType name="PipelineComponentOutputColumnType">
  <xs:sequence>
    <xs:element name="properties"
      type="DTS:PipelineComponentOutputColumnPropertiesType"
      form="unqualified" minOccurs="0" maxOccurs="unbounded"/>
  </xs:sequence>
  <xs:attributeGroup
    ref="DTS:PipelineComponentAllColumnBaseAttributeGroup"/>
  <xs:attributeGroup
    ref="DTS:PipelineComponentIOColumnBaseAttributeGroup"/>
  <xs:attributeGroup
    ref="DTS:PipelineComponentColumnExtendedAttributeGroup"/>
  <xs:attribute name="sortKeyPosition" type="xs:int"
    use="optional" default="0" form="unqualified"/>
  <xs:attribute name="comparisonFlags" type="xs:int"
    form="unqualified" use="optional" default="0" />
  <xs:attribute name="specialFlags" form="unqualified"
    use="optional" default="0">
```

```

<xs:simpleType>
  <xs:restriction base="xs:int">
    <xs:minInclusive value="0"/>
    <xs:maxInclusive value="2"/>
  </xs:restriction>
</xs:simpleType>
</xs:attribute>
</xs:complexType>

```

The following table specifies the elements of the **PipelineComponentOutputColumnType** complex type.

Element	Type definition	Description
properties	PipelineComponentPropertiesType	A complex type that specifies a collection of properties for an output column.

The following table specifies the attributes and attribute groups of the **PipelineComponentOutputColumnType** complex type.

Attribute group or attribute	Description
PipelineComponentAllColumnBaseAttributeGroup	An attribute group specification that specifies attributes that are common to all types of columns for Pipeline components.
PipelineComponentIOColumnBaseAttributeGroup	An attribute group specification that specifies attributes that are common to all input and output columns for Pipeline components.
PipelineComponentColumnExtendedAttributeGroup	An attribute group specification that specifies additional attributes present for the PipelineComponentOutputColumnType complex type.
sortKeyPosition	An integer value that specifies the position of this column among the sort keys.
comparisonFlags	An integer value that is a bitmask that specifies which options are chosen for comparison of values in the column. The interpretation of the bits in this integer is as follows: 0x00000001 – Ignore case. 0x00000002 – Ignore nonspace characters. 0x00000004 – Ignore symbols. 0x00000010 – Linguistically appropriate ignore case. 0x00000020 – Linguistically appropriate ignore nonspace characters. 0x00010000 – Ignore Kana type. 0x00020000 – Ignore width. 0x08000000 – Use linguistic rules for casing.
specialFlags	An integer enumeration value that specifies whether the column contains special information. The allowed

Attribute group or attribute	Description
	values are the following: 0 – No special information is contained in the column. 1 – The data in the column contains error codes. 2 – The data in the column contains the LineageID of the column in which an error occurred.

2.7.1.1.1.4.1.1.2 PipelineComponentOutputColumnPropertiesType

The **PipelineComponentOutputColumnPropertiesType** complex type specifies a collection of properties for an **outputColumn** element that is part of a Pipeline component.

The following is the XSD for the **PipelineComponentOutputColumnPropertiesType** complex type.

```
<xs:complexType name="PipelineComponentOutputColumnPropertiesType">
  <xs:sequence>
    <xs:element name="property" form="unqualified"
      type="DTS:PipelineComponentOutputColumnPropertyType"
      minOccurs="0" maxOccurs="unbounded"/>
  </xs:sequence>
</xs:complexType>
```

The following table specifies the elements of the **PipelineComponentOutputColumnPropertiesType** complex type.

Element	Type definition	Description
property	PipelineComponentOutputColumnPropertyType	A complex type that specifies a single property within a collection of input column properties for an outputColumn element of a Pipeline component.

2.7.1.1.1.4.1.1.2.1 PipelineComponentOutputColumnPropertyType

The **PipelineComponentOutputColumnPropertyType** complex type specifies a property for an **outputColumn** element.

The following is the XSD for the **PipelineComponentOutputColumnPropertyType** complex type.

```
<xs:complexType name="PipelineComponentOutputColumnPropertyType">
  <xs:simpleContent>
    <xs:extension base="xs:anySimpleType">
      <xs:attributeGroup
        ref="DTS:PipelineComponentPropertyAttributeGroup"/>
      <xs:attribute name="name" form="unqualified" use="required"
        type="DTS:PipelineComponentOutputColumnPropertyNameEnum"/>
    </xs:extension>
  </xs:simpleContent>
</xs:complexType>
```

The following table specifies the attribute groups of the **PipelineComponentOutputColumnPropertyType** complex type.

Attribute group	Description
PipelineComponentPropertyAttributeGroup	An attribute group that contains attributes that are common to all property elements for input elements, output elements, inputColumn elements, and outputColumn elements.
name	An enumeration value that specifies the name of the property.

2.7.1.1.1.4.1.1.2.1.1 PipelineComponentOutputColumnPropertyNameEnum

The **PipelineComponentOutputColumnPropertyNameEnum** type contains the allowed values for the **name** attribute on the **outputColumn** element of a Pipeline component. The allowed values for the **property** element for each task are more restricted than the values that are specified formally by the XSD.

Each **name** attribute value MUST NOT be used for any component except for the components that are specified in the subsections to this section. Some components allow no properties.

The additional restrictions specified in the subsections to this section MUST be followed for the **name** attribute on the **property** element children of the **outputColumn** element.

```
<xs:simpleType name="PipelineComponentOutputColumnPropertyNameEnum">
  <xs:restriction base="xs:string">
    <!--Transforms-->
    <!--Aggregate Task-->
    <xs:enumeration value="AggregationColumnId"/>
    <xs:enumeration value="AggregationType"/>
    <xs:enumeration value="IsBig"/>
    <xs:enumeration value="AggregationComparisonFlags"/>
    <xs:enumeration value="CountDistinctKey"/>
    <xs:enumeration value="CountDistinctScale"/>
    <!--Audit-->
    <xs:enumeration value="LineageItemSelected"/>
    <!--Cache Transform (none)-->
    <!--Character Map (none)-->
    <!--Conditional Split (none)-->
    <!--Copy Column (none)-->
    <xs:enumeration value="copyColumnId"/>
    <!--Data Conversion (none)-->
    <xs:enumeration value="SourceInputColumnLineageID"/>
    <xs:enumeration value="FastParse"/>
    <!--Data Mining Query-->
    <!--Derived Column Query (none)-->
    <xs:enumeration value="Expression"/>
    <xs:enumeration value="FriendlyExpression"/>
    <!--Export Column Query (none)-->
    <!--Fuzzy Grouping-->
    <xs:enumeration value="ColumnType"/>
    <xs:enumeration value="InputId"/>
    <!--Fuzzy Lookup-->
    <xs:enumeration value="CopyFromReferenceColumn"/>
  </xs:restriction>
</xs:simpleType>
```

```

<xs:enumeration value="SourceInputColumnLineageID"/>
<xs:enumeration value="ColumnType"/>
<!--Import Column (none)-->
<!--Lookup-->
<xs:enumeration value="CopyFromReferenceColumn"/>
<!--Merge (none)-->
<!--MergeJoin-->
<xs:enumeration value="InputColumnID"/>
<!--Multicast (none)-->
<!--OLE DB Command (none)-->
<!--Percentage Sampling (none)-->
<!--Pivot-->
<xs:enumeration value="SourceColumn"/>
<xs:enumeration value="PivotKeyValue"/>
<!--RowCount (none)-->
<!--Row Sampling-->
<xs:enumeration value="InputColumnLineageID"/>
<!--Script Component (none)-->
<!--Slowly Changing Dimension (none)-->
<!--Sort-->
<xs:enumeration value="SortColumnId"/>
<!--Term Extraction (none)-->
<!--Term Lookup-->
<xs:enumeration value="CustomLineageID"/>
<!--UnionAll (none)-->
<!--Unpivot (none)-->
<xs:enumeration value="PivotKey"/>
<!--Data Sources-->
<!--ADO.Net Source (none)-->
<!--Excel Source (none)-->
<!--Flat File Source-->
<xs:enumeration value="FastParse"/>
<xs:enumeration value="UseBinaryFormat"/>
<!--OLEDB Source Task (none)-->
<!--Raw File Source (none)-->
<!--XML Source (none)-->
</xs:restriction>
</xs:simpleType>

```

2.7.1.1.1.4.1.1.2.1.1.1 Aggregate Component outputColumn Element

The Aggregate Component **outputColumn** element MUST NOT use any **Name** attribute value on a **property** element except for those that are listed in the table in this section.

The following table specifies the name attribute values that are allowed for the Aggregate Component on the **outputColumn** element, in addition to any restrictions on the element value. These restrictions MUST be followed.

Name attribute value	Description
AggregationColumnId	The property element value MUST be an integer. This value specifies the LineageID of a column that participates in a GroupBy or an aggregation operation.
AggregationType	The property element value MUST be an integer between 0 and 7. This value specifies the type of aggregation to be performed. The enumeration values are interpreted as follows:

Name attribute value	Description
	0 – Group by 1 – Count 2 – Count all 3 – Count distinct 4 – Sum 5 – Average 6 – Minimum 7 – Maximum
IsBig	The property element value MUST be a Boolean. This value specifies whether the column has a very large value (greater than 4 billion) or a very precise value (more precision than double precision). TRUE specifies that the column contains a very large or very precise value. FALSE specifies that the column does not contain a very large or very precise value.
AggregationComparisonFlags	The property element value MUST be an integer value. This integer value is a bitmask that specifies the comparison flags for the sort operation. The bit values are as follows: 0x00000001 - Ignore case. 0x00000002 - Ignore nonspace characters. 0x00001000 - Ignore Kana type. 0x00002000 - Ignore character width.
CountDistinctScale	The property element value MUST be an integer between 0 and 3. This value specifies the approximate number of groups that is expected by the operation. This value is used to optimize computation. The enumeration values are interpreted as follows: 0 – The key scale is not used. 1 – Aggregation writes 0 to 500,000 keys. 2 – Aggregation writes 500,000 to 25,000,000 keys. 3 – Aggregation writes more than 25,000,000 keys.
CountDistinctKeys	The property element value MUST be an integer. This value specifies the exact number of GroupBy keys that can be written. If this value is specified, it takes precedence over the value of the CountDistinctScale attribute.

2.7.1.1.1.4.1.1.2.1.1.2 Audit Component outputColumn Element

The Audit Component **outputColumn** element MUST NOT use any **Name** attribute value on a **property** element except for those that are listed in the table in this section.

The following table specifies the **Name** attribute values that are allowed for the Audit Component on the **outputColumn** element, in addition to any restrictions on the element value. These restrictions MUST be followed.

Name attribute value	Description
LineageItemSelected	The property element value MUST be an integer between 0 and 8. This

Name attribute value	Description
	enumeration value specifies the audit item that is selected for output. The allowed values are as follows: 0 - Execution instance GUID. 1 - Package ID. 2 - Package name. 3 - Version ID. 4 - Execution start time. 5 - Machine name. 6 - User name. 7 - Task name. 8 - Task ID.

2.7.1.1.1.1.4.1.1.2.1.1.3 Cache Transform Component outputColumn Element

The Cache Transform Component MUST NOT have any properties on the **outputColumn** element.

2.7.1.1.1.1.4.1.1.2.1.1.4 Character Map Component outputColumn Element

The Character Map Component MUST NOT have any properties on the **outputColumn** element.

2.7.1.1.1.1.4.1.1.2.1.1.5 Conditional Split Component outputColumn Element

The Conditional Split Component MUST NOT have any properties on the **outputColumn** element.

2.7.1.1.1.1.4.1.1.2.1.1.6 Copy Column Component outputColumn Element

The Copy Column Component **outputColumn** element MUST NOT use any **Name** attribute value on a **property** element except for those that are listed in the table in this section.

The following table specifies the **Name** attribute values that are allowed for the Copy Column Component on the **outputColumn** element, in addition to any restrictions on the element value. These restrictions MUST be followed.

Name attribute value	Description
copyColumnId	The property element value MUST be an integer. This value specifies the LineageID of the column to copy.

2.7.1.1.1.1.4.1.1.2.1.1.7 Data Conversion Component outputColumn Element

The Data Conversion Component **outputColumn** element MUST NOT use any **Name** attribute value on a **property** element except for those that are listed in the table in this section.

The following table specifies the **Name** attribute values that are allowed for the Data Conversion Component on the **outputColumn** element, in addition to any restrictions on the element value. These restrictions MUST be followed.

Name attribute value	Description
SourceInputColumnLineageID	The property element value MUST be an integer. This value specifies the LineageID of the source input column.
FastParse	The property element value MUST be a Boolean. This value specifies whether to use the locale-neutral fast parse algorithm. TRUE specifies to use the fast parse algorithm. FALSE specifies not to use the fast parse algorithm.

2.7.1.1.1.4.1.1.2.1.1.8 Data Mining Query Component outputColumn Element

The Data Mining Query Component MUST NOT have any properties on the **outputColumn** element.

2.7.1.1.1.4.1.1.2.1.1.9 Derived Column Component outputColumn Element

The Derived Column Component **outputColumn** element MUST NOT use any **Name** attribute value on a **property** element except for those that are listed in the table in this section.

The following table specifies the **Name** attribute values that are allowed for the Derived Column Component on the **outputColumn** element, in addition to any restrictions on the element value. These restrictions MUST be followed.

Name attribute value	Description
Expression	The property element value MUST be a string value. This value specifies the expression by which the column is derived.
FriendlyExpression	The property element value MUST be a Boolean. This value specifies whether to use the locale-neutral fast parse algorithm. TRUE specifies to use the fast parse algorithm. FALSE specifies not to use the fast parse algorithm.

2.7.1.1.1.4.1.1.2.1.1.10 Export Column Component outputColumn Element

The Export Column Component MUST NOT have any properties on the **outputColumn** element.

2.7.1.1.1.4.1.1.2.1.1.11 Fuzzy Grouping Component outputColumn Element

The Fuzzy Grouping Component **outputColumn** element MUST NOT use any **Name** attribute value on a **property** element except for those that are listed in the table in this section.

The following table specifies the **Name** attribute values that are allowed for the Fuzzy Grouping Component on the **outputColumn** element, in addition to any restrictions on the element value. These restrictions MUST be followed.

Name attribute value	Description
ColumnType	The property element value MUST be an integer between 0 and 6. This value specifies the type of the column. The allowed values are as follows: 0 – The type of the column is undefined.

Name attribute value	Description
	1 – The column is a key input. 2 – The column is a key output. 3 – The column contains the similarity value. 4 – The column contains the column similarity value. 5 – The column is passthrough. 6 – The column is canonical.
InputId	The property element value MUST be an integer. This value specifies the LineageID of the corresponding input column.

2.7.1.1.1.4.1.1.2.1.1.12 Fuzzy Lookup Component outputColumn Element

The Fuzzy Lookup Component **outputColumn** element MUST NOT use any **Name** attribute value on a **property** element except for those that are listed in the table in this section.

The following table specifies the **Name** attribute values that are allowed for the Fuzzy Lookup Component on the **outputColumn** element, in addition to any restrictions on the element value. These restrictions MUST be followed.

Name attribute value	Description
CopyFromReferenceColumn	The property element value MUST be a string. This value specifies the name of the column in the reference table that provides the values for this output column.
SourceInputColumnLineageID	The property element value MUST be an integer. This value specifies the LineageID of the source input column.
ColumnType	The property element value MUST be an integer between 0 and 3. This value specifies the type of the column. 0 – The type of the column is undefined. 1 – The column contains the similarity value. 2 – The column contains the confidence value. 3 – The column contains the column similarity value.
InputId	The property element value MUST be an integer. This value specifies the LineageID of the corresponding input column.

2.7.1.1.1.4.1.1.2.1.1.13 Import Column Component outputColumn Element

The Import Column Component MUST NOT have any properties on the **outputColumn** element.

2.7.1.1.1.4.1.1.2.1.1.14 Lookup Component outputColumn Element

The Lookup Component **outputColumn** element MUST NOT use any **Name** attribute value on a **property** element except for those that are listed in the table in this section.

The following table specifies the **Name** attribute values that are allowed for the Lookup Component on the **outputColumn** element, in addition to any restrictions on the element value. These restrictions MUST be followed.

Name attribute value	Description
CopyFromReferenceColumn	The property element value MUST be a string. This value specifies the name of the column in the reference table that provides the values for this output column.

2.7.1.1.1.4.1.1.2.1.1.15 Merge Component outputColumn Element

The Merge Component **outputColumn** element MUST NOT use any **Name** attribute value on a **property** element except for those that are listed in the table in this section.

The following table specifies the **Name** attribute values that are allowed for the Merge Component on the **outputColumn** element, in addition to any restrictions on the element value. These restrictions MUST be followed.

Name attribute value	Description
OutputColumnLineageID	The property element value MUST be a string. This value specifies the LineageID of the output column.

2.7.1.1.1.4.1.1.2.1.1.16 MergeJoin Component outputColumn Element

The MergeJoin Component **outputColumn** element MUST NOT use any **Name** attribute value on a **property** element except for those that are listed in the table in this section.

The following table specifies the **Name** attribute values that are allowed for the MergeJoin Component on the **outputColumn** element, in addition to any restrictions on the element value. These restrictions MUST be followed.

Name attribute value	Description
InputColumnID	The property element value MUST be a string. This value specifies the LineageID of the input column from which data is copied to this output column.

2.7.1.1.1.4.1.1.2.1.1.17 Multicast Component outputColumn Element

The Multicast Component MUST NOT have any properties on the **outputColumn** element.

2.7.1.1.1.4.1.1.2.1.1.18 OLE DB Command Component outputColumn Element

The OLE DB Command Component MUST NOT have any properties on the **outputColumn** element.

2.7.1.1.1.4.1.1.2.1.1.19 Percentage Sampling Component outputColumn Element

The Percentage Sampling Component MUST NOT have any properties on the **outputColumn** element.

2.7.1.1.1.4.1.1.2.1.1.20 Pivot Component outputColumn Element

The Pivot Component **outputColumn** element MUST NOT use any **Name** attribute value on a **property** element except for those that are listed in the table in this section.

The following table specifies the **Name** attribute values that are allowed for the Pivot Component on the **outputColumn** element, in addition to any restrictions on the element value. These restrictions MUST be followed.

Name attribute value	Description
SourceColumn	The property element value MUST be an integer. This value specifies the LineageID of the input column that contains a pivoted value. <58>
PivotKeyValue	The property element value MUST be a string value. This value specifies one of the possible set of pivot keys that are identified in the input.

2.7.1.1.1.4.1.1.2.1.1.21 RowCount Component outputColumn Element

The RowCount Component MUST NOT have any properties on the **outputColumn** element.

2.7.1.1.1.4.1.1.2.1.1.22 Row Sampling Component outputColumn Element

The Row Sampling Component **outputColumn** element MUST NOT use any **Name** attribute value on a **property** element except for those that are listed in the table in this section.

The following table specifies the **Name** attribute values that are allowed for the Row Sampling Component on the **outputColumn** element, in addition to any restrictions on the element value. These restrictions MUST be followed.

Name attribute value	Description
InputColumnLineageID	The property element value MUST be an integer. This value specifies the LineageID of the input column that is the source of this output column.

2.7.1.1.1.4.1.1.2.1.1.23 Script Component outputColumn Element

The Script Component MUST NOT have any properties on the **outputColumn** element.

2.7.1.1.1.4.1.1.2.1.1.24 Slowly Changing Dimension Component outputColumn Element

The Slowly Changing Dimension Component MUST NOT have any properties on the **outputColumn** element.

2.7.1.1.1.4.1.1.2.1.1.25 Sort Component outputColumn Element

The Sort Component **outputColumn** element MUST NOT use any **Name** attribute value on a **property** element except for those that are listed in the table in this section.

The following table specifies the **Name** attribute values that are allowed for the Sort Component on the **outputColumn** element, in addition to any restrictions on the element value. These restrictions MUST be followed.

Name attribute value	Description
SortColumnID	The property element value MUST be an integer. This value specifies the

Name attribute value	Description
	LineageID of the sort column.

2.7.1.1.1.4.1.1.2.1.1.26 Term Extraction Component outputColumn Element

The Term Extraction Component MUST NOT have any properties on the **outputColumn** element.

2.7.1.1.1.4.1.1.2.1.1.27 Term Lookup Component outputColumn Element

The Term Lookup Component **outputColumn** element MUST NOT use any **Name** attribute value on a **property** element except for those that are listed in the table in this section.

The following table specifies the **Name** attribute values that are allowed for the Term Lookup Component on the **outputColumn** element, in addition to any restrictions on the element value. These restrictions MUST be followed.

Name attribute value	Description
CustomLineageID	The property element value MUST be an integer. This value specifies the LineageID of the corresponding input column.

2.7.1.1.1.4.1.1.2.1.1.28 Union All Component outputColumn Element

The Union All Component MUST NOT have any properties on the **outputColumn** element.

2.7.1.1.1.4.1.1.2.1.1.29 Unpivot Component outputColumn Element

The Unpivot Component **outputColumn** element MUST NOT use any **Name** attribute value on a **property** element except for those that are listed in the table in this section.

The following table specifies the **Name** attribute values that are allowed for the Unpivot Component on the **outputColumn** element, in addition to any restrictions on the element value. These restrictions MUST be followed.

Name attribute value	Description
PivotKey	The property element value MUST be a Boolean. This value specifies whether the PivotKeyValue property of input columns is written to this output column. TRUE specifies that the PivotKeyValue property of input columns is written to this output column. FALSE specifies that the PivotKeyValue property of input columns is not written to this output column.

2.7.1.1.1.4.1.1.2.1.1.30 ADO.NET Source Component outputColumn Element

The ADO.NET Source Component MUST NOT have any properties on the **outputColumn** element.

2.7.1.1.1.4.1.1.2.1.1.31 Excel Source Component outputColumn Element

The Excel Source Component MUST NOT have any properties on the **outputColumn** element.

2.7.1.1.1.4.1.1.2.1.1.32 Flat File Source Component outputColumn Element

The Flat File Source Component **outputColumn** element MUST NOT use any **Name** attribute value on a **property** element except for those that are listed in the table in this section.

The following table specifies the **Name** attribute values that are allowed for the Flat File Source Component on the **outputColumn** element, in addition to any restrictions on the element value. These restrictions MUST be followed.

Name attribute value	Description
FastParse	The property element value MUST be a Boolean. This value specifies whether the component uses the faster locale-insensitive parsing method. TRUE specifies that the faster locale-insensitive parsing method is used. FALSE specifies that the faster locale-insensitive parsing method is not used.
UseBinaryFormat	The property element value MUST be a Boolean. This value specifies whether data from the source is in binary format TRUE specifies that the data is in binary format. FALSE specifies that the data is not in binary format.

2.7.1.1.1.4.1.1.2.1.1.33 OLE DB Source Component outputColumn Element

The OLE DB Source Component MUST NOT have any properties on the **outputColumn** element.

2.7.1.1.1.4.1.1.2.1.1.34 Raw File Source Component outputColumn Element

The **Raw File Source Component** MUST NOT have any properties on the **outputColumn** element.

2.7.1.1.1.4.1.1.2.1.1.35 XML Source Component outputColumn Element

The XML Source Component MUST NOT have any properties on the **outputColumn** element.

2.7.1.1.1.4.1.2 PipelineComponentOutputPropertiesType

The **PipelineComponentOutputPropertiesType** complex type specifies a collection of properties for an **output** element that is part of a Pipeline component.

The following is the XSD for the **PipelineComponentOutputPropertiesType** complex type.

```
<xs:complexType name="PipelineComponentOutputPropertiesType">
  <xs:sequence>
    <xs:element name="property" form="unqualified"
      type="DTS:PipelineComponentOutputPropertyType"
      minOccurs="0" maxOccurs="unbounded"/>
  </xs:sequence>
</xs:complexType>
```

The following table specifies the elements of the **PipelineComponentOutputPropertiesType** complex type.

Element	Type definition	Description
property	PipelineComponentOutputPropertyType	A complex type that specifies a single property within a collection of output properties for an output element of a Pipeline component.

2.7.1.1.1.4.1.2.1 PipelineComponentOutputPropertyType

The **PipelineComponentOutputPropertyType** complex type specifies the structure in which the value for a single property of an output of a component is held. All outputs do not use the same set of properties, so this general structure is designed to hold the variety of properties that an output can have.

The following is the XSD for the **PipelineComponentOutputPropertyType** complex type.

```
<xs:complexType name="PipelineComponentOutputPropertyType"
  mixed="true">
  <xs:sequence>
    <xs:element name="arrayElements"
      type="DTS:PipelineComponentArrayElementsType"
      form="unqualified" minOccurs="0"/>
  </xs:sequence>
  <xs:attributeGroup
    ref="DTS:PipelineComponentPropertyAttributeGroup"/>
  <xs:attribute name="name" use="required"
    type="DTS:PipelineComponentOutputPropertyNameEnum"
    form="unqualified"/>
</xs:complexType>
```

The following table specifies the elements of the **PipelineComponentOutputPropertyType** complex type.

Element	Type definition	Description
arrayElements	PipelineComponentArrayElementsType	A complex type that contains a collection of elements that form an array. The collection constitutes the value for the property. This value is used only if the isArray attribute value is TRUE.

The following table specifies the attributes of the **PipelineComponentOutputPropertyType** complex type.

Attribute	Description
name	An enumeration value that specifies the name of the property.
PipelineComponentPropertyAttributeGroup	An attribute group that contains attributes that are common to all property elements for input elements, output elements, inputColumn elements, and outputColumn elements.

2.7.1.1.1.4.1.2.1.1 PipelineComponentOutputPropertyNameEnum

The **PipelineComponentOutputPropertyNameEnum** type contains the allowed values for the **name** attribute on the **output** element of a component of a Pipeline executable. The allowed values for the **property** element for each task are more restricted than the values that are specified formally by the XSD.

Each **name** attribute value MUST NOT be used for any **output** element except for the components that are specified in the subsections to this section. Some components allow no properties on the **output** element.

The additional restrictions that are specified in the subsections to this section MUST be followed for the **name** attribute on the **property** element children of the **output** element.

The following is the XSD for the **PipelineComponentOutputPropertyNameEnum** type.

```
<xs:simpleType name="PipelineComponentOutputPropertyNameEnum">
  <xs:restriction base="xs:string">
    <!--Transforms-->
    <!--Aggregate Task-->
    <xs:enumeration value="KeyScale"/>
    <xs:enumeration value="Keys"/>
    <!--Audit (none)-->
    <!--Cache Transform (none)-->
    <!--Character Map (none)-->
    <!--Conditional Split-->
    <xs:enumeration value="Expression"/>
    <xs:enumeration value="FriendlyExpression"/>
    <xs:enumeration value="EvaluationOrder"/>
    <xs:enumeration value="IsDefaultOut"/>
    <!--Copy Column (none)-->
    <!--Data Conversion (none)-->
    <!--Data Mining Query(none)-->
    <!--Derived Column Query (none)-->
    <!--Export Column Query (none)-->
    <!--Fuzzy Grouping(none)-->
    <!--Fuzzy Lookup(none)-->
    <!--Import Column (none)-->
    <!--Lookup(none)-->
    <!--Merge (none)-->
    <!--MergeJoin (none)-->
    <!--Multicast (none)-->
    <!--OLE DB Command(none)-->
    <!--Percentage Sampling-->
    <xs:enumeration value="Selected"/>
    <!--Pivot (none)-->
    <!--RowCount (none)-->
    <!--Row Sampling-->
    <xs:enumeration value="Selected"/>
    <!--Script Component(none)-->
    <!--Slowly Changing Dimension(none)-->
    <!--Sort(none)-->
    <!--Term Extraction(none)-->
    <!--Term Lookup(none)-->
    <!--UnionAll (none)-->
    <!--Unpivot (none)-->
    <!--Data Sources(none)-->
```

```

<!--ADO.Net Source (none)-->
<!--Excel Source (none)-->
<!--Flat File Source (none)-->
<!--OLEDB Source Task (none)-->
<!--Raw File Source (none)-->
<!--XML Source-->
<xs:enumeration value="RowsetID"/>
</xs:restriction>
</xs:simpleType>

```

2.7.1.1.1.4.1.2.1.1.1 Aggregate Component output Element

The Aggregate Component **output** element MUST NOT use any **Name** attribute value on a **property** element except for those that are listed in the table in this section.

The following table specifies the **Name** attribute values that are allowed for the Aggregate Component, in addition to any restrictions on the element value. These restrictions MUST be followed.

Name attribute value	Description
KeyScale	<p>The property element value MUST be an integer between 0 and 3. This value that specifies the approximate number of groups expected by the operation. This value is used to optimize computation. The enumeration values are interpreted as follows:</p> <ul style="list-style-type: none"> 0 – The key scale is not used. 1 – The aggregation writes approximately 500,000 keys. 2 – The aggregation writes approximately 25,000,000 keys. 3 – The aggregation writes more than 25,000,000 keys.
Keys	<p>The property element value MUST be an integer. This value specifies the exact number of GroupBy keys that can be written. If this value is specified, it takes precedence over the value of the KeyScale attribute.</p>

2.7.1.1.1.4.1.2.1.1.2 Audit Component output Element

The Audit Component **output** element MUST NOT have any properties.

2.7.1.1.1.4.1.2.1.1.3 Cache Transform Component output Element

The Cache Transform Component **output** element MUST NOT have any properties.

2.7.1.1.1.4.1.2.1.1.4 Character Map Component output Element

The Character Map Component **output** element MUST NOT have any properties.

2.7.1.1.1.4.1.2.1.1.5 Conditional Split Component output Element

The Conditional Split Component **output** element MUST NOT use any **Name** attribute value on a **property** element except for those that are listed in the table in this section.

The following table specifies the **Name** attribute values that are allowed for the Conditional Split Component, in addition to any restrictions on the element value. These restrictions MUST be followed.

Name attribute value	Description
Expression	The property element value MUST be a string value. This value specifies a conditional expression that is evaluated to determine the conditional split.
FriendlyExpression	The property element value MUST be a string value. This value specifies a conditional expression that is evaluated to determine the conditional split. The FriendlyExpression attribute uses column names in the expression syntax, while the Expression attribute uses only column LineageIDs.
EvaluationOrder	The property element value MUST be an integer. This value specifies the order in which the expression is evaluated, from lowest to highest.
IsDefaultOut	The property element value MUST be a Boolean. This value specifies whether an output is the default output. TRUE specifies that the output is the default output. FALSE specifies that the output is not the default output.

2.7.1.1.1.1.4.1.2.1.1.6 Copy Column Component output Element

The Copy Column Component **output** element MUST NOT have any properties.

2.7.1.1.1.1.4.1.2.1.1.7 Data Conversion Component output Element

The Data Conversion Component **output** element MUST NOT have any properties.

2.7.1.1.1.1.4.1.2.1.1.8 Data Mining Query Component output Element

The Data Mining Query Component **output** element MUST NOT have any properties.

2.7.1.1.1.1.4.1.2.1.1.9 Derived Column Component output Element

The Derived Column Component **output** element MUST NOT have any properties.

2.7.1.1.1.1.4.1.2.1.1.10 Export Column Component output Element

The Export Column Component **output** element MUST NOT have any properties.

2.7.1.1.1.1.4.1.2.1.1.11 Fuzzy Grouping Component output Element

The Fuzzy Grouping Component **output** element MUST NOT have any properties.

2.7.1.1.1.1.4.1.2.1.1.12 Fuzzy Lookup Component output Element

The Fuzzy Lookup Component **output** element MUST NOT have any properties.

2.7.1.1.1.1.4.1.2.1.1.13 Import Column Component output Element

The Import Column Component **output** element MUST NOT have any properties.

2.7.1.1.1.1.4.1.2.1.1.14 Lookup Component output Element

The Lookup Component **output** element MUST NOT have any properties.

2.7.1.1.1.1.4.1.2.1.1.15 Merge Component output Element

The Merge Component **output** element MUST NOT have any properties.

2.7.1.1.1.1.4.1.2.1.1.16 MergeJoin Component output Element

The MergeJoin Component **output** element MUST NOT have any properties.

2.7.1.1.1.1.4.1.2.1.1.17 Multicast Component output Element

The Multicast Component **output** element MUST NOT have any properties.

2.7.1.1.1.1.4.1.2.1.1.18 OLE DB Command Component output Element

The OLE DB Command Component **output** element MUST NOT have any properties.

2.7.1.1.1.1.4.1.2.1.1.19 Percentage Sampling Component output Element

The Percentage Sampling Component **output** element MUST NOT use any **Name** attribute value on a **property** element except for those that are listed in the table in this section.

The following table specifies the **Name** attribute values that are allowed for the Percentage Sampling Component, in addition to any restrictions on the element value. These restrictions MUST be followed.

Name attribute value	Description
Selected	The property element value MUST be a Boolean value. This value specifies to which output sampled output is directed. TRUE specifies that sampled output is directed to this output. FALSE specifies that sampled output is not directed to this output.

2.7.1.1.1.1.4.1.2.1.1.20 Pivot Component output Element

The Pivot Component **output** element MUST NOT have any properties.

2.7.1.1.1.1.4.1.2.1.1.21 RowCount Component output Element

The RowCount Component **output** element MUST NOT have any properties.

2.7.1.1.1.1.4.1.2.1.1.22 Row Sampling Component output Element

The Row Sampling Component **output** element MUST NOT use any **Name** attribute value on a **property** element except for those that are listed in the table in this section.

The following table specifies the **Name** attribute values that are allowed for the Row Sampling Component, in addition to any restrictions on the element value. These restrictions MUST be followed.

Name attribute value	Description
Selected	<p>The property element value MUST be a Boolean value. This value specifies to which output sampled output is directed.</p> <p>TRUE specifies that sampled output is directed to this output.</p> <p>FALSE specifies that sampled output is not directed to this output.</p>

2.7.1.1.1.1.4.1.2.1.1.23 Script Component output Element

The Script Component **output** element MUST NOT have any properties.

2.7.1.1.1.1.4.1.2.1.1.24 Slowly Changing Dimension Component output Element

The Slowly Changing Dimension Component **output** element MUST NOT have any properties.

2.7.1.1.1.1.4.1.2.1.1.25 Sort Component output Element

The Sort Component **output** element MUST NOT have any properties.

2.7.1.1.1.1.4.1.2.1.1.26 Term Extraction Component output Element

The Term Extraction Component **output** element MUST NOT have any properties.

2.7.1.1.1.1.4.1.2.1.1.27 Term Lookup Component output Element

The Term Lookup Component **output** element MUST NOT have any properties.

2.7.1.1.1.1.4.1.2.1.1.28 Union All Component output Element

The Union All Component **output** element MUST NOT have any properties.

2.7.1.1.1.1.4.1.2.1.1.29 Unpivot Component output Element

The Unpivot Component **output** element MUST NOT have any properties.

2.7.1.1.1.1.4.1.2.1.1.30 ADO.NET Source Component output Element

The ADO.NET Source Component **output** element MUST NOT have any properties.

2.7.1.1.1.1.4.1.2.1.1.31 Excel Source Component output Element

The Excel Source Component **output** element MUST NOT have any properties.

2.7.1.1.1.1.4.1.2.1.1.32 Flat File Source Component output Element

The Flat File Source Component **output** element MUST NOT have any properties.

2.7.1.1.1.1.4.1.2.1.1.33 OLE DB Source Component output Element

The OLE DB Source Component **output** element MUST NOT have any properties.

2.7.1.1.1.4.1.2.1.1.34 Raw File Source Component output Element

The Raw File Source Component **output** element MUST NOT have any properties.

2.7.1.1.1.4.1.2.1.1.35 XML Source Component output Element

The XML Source Component **output** element MUST NOT use any **Name** attribute value on a **property** element except for those that are listed in the table in this section.

The following table specifies the **Name** attribute values that are allowed for the XML Source Component, in addition to any restrictions on the element value. These restrictions MUST be followed.

Name attribute value	Description
RowsetID	The property element value MUST be a string. This value specifies the name of the rowset that is associated with the output.

2.7.1.1.1.4.1.3 PipelineComponentRowDispositionEnum

The **PipelineComponentRowDispositionEnum** type contains the enumeration values for the **state** attribute.

The following is the XSD for the **PipelineComponentRowDispositionEnum** type.

```
<xs:simpleType name="PipelineComponentRowDispositionEnum">
  <xs:restriction base="xs:string">
    <xs:enumeration value="NotUsed"/>
    <xs:enumeration value="IgnoreFailure"/>
    <xs:enumeration value="FailComponent"/>
    <xs:enumeration value="RedirectRow"/>
  </xs:restriction>
</xs:simpleType>
```

The following table specifies the enumeration values for the **PipelineComponentRowDispositionEnum** type.

Enumeration value	Description
NotUsed	Specifies that row processing is not used.
IgnoreFailure	Specifies that the component ignores the failure and continue processing.
FailComponent	Specifies that the component's execution fails.
RedirectRow	Specifies that any row that causes a failure is redirected to the error output.

2.7.1.1.1.5 PipelineComponentComponentClassIDEnum

The **PipelineComponentComponentClassIDEnum** type contains the enumeration values for the **componentClassID** attribute.

The following is the XSD for the **PipelineComponentComponentClassIDEnum** type.

```

<xs:simpleType name="PipelineComponentComponentClassIDEnum">
  <xs:restriction base="DTS:uuid">
    <!--Transforms-->
    <!--Aggregate-->
    <xs:enumeration value="{5B201335-B360-485C-BB93-75C34E09B3D3}"/>
    <!--Audit-->
    <xs:enumeration value="{4FCE8297-9C65-40A9-9D60-00C5CC6BC283}"/>
    <!--Cache Transform-->
    <xs:enumeration value="{BF818E79-2C1C-410D-ADEA-B2D1A04FED01}"/>
    <!--Character Map-->
    <xs:enumeration value="{C86C867A-7D40-486A-8734-F0B6943A9DD4}"/>
    <!--Conditional Split-->
    <xs:enumeration value="{7F88F654-4E20-4D14-84F4-AF9C925D3087}"/>
    <!--Copy Column-->
    <xs:enumeration value="{D231ABC4-4754-481B-8F7A-CD4BD8D09832}"/>
    <!--Data Conversion-->
    <xs:enumeration value="{62B1106C-7DB8-4EC8-ADD6-4C664DFFC54A}"/>
    <!--Data Mining Query-->
    <xs:enumeration value="{CBDF0CC-3758-4424-A431-3C2E103069AA}"/>
    <!--Derived Column-->
    <xs:enumeration value="{49928E82-9C4E-49F0-AABE-3812B82707EC}"/>
    <!--Export Column-->
    <xs:enumeration value="{A9823821-0085-4483-952F-36277F63FFC5}"/>
    <!--Fuzzy Grouping-->
    <xs:enumeration value="{836E0D0B-0358-45B4-B888-4ADCE9356D4E}"/>
    <!--Fuzzy Lookup-->
    <xs:enumeration value="{E4A5F949-EC93-45AB-8B36-B52936257EC2}"/>
    <!--Import Column-->
    <xs:enumeration value="{9053CAE0-140B-48E4-AEEC-4E6A26E9E436}"/>
    <!--Lookup-->
    <xs:enumeration value="{671046B0-AA63-4C9F-90E4-C06E0B710CE3}"/>
    <!--Merge-->
    <xs:enumeration value="{36E0E750-2510-4776-AA6E-17EAE84FD63E}"/>
    <!--MergeJoin-->
    <xs:enumeration value="{14D43A4F-D7BD-489D-829E-6DE35750CFE4}"/>
    <!--Multicast-->
    <xs:enumeration value="{EC139FBC-694E-490B-8EA7-35690FB0F445}"/>
    <!--OLE DB Command-->
    <xs:enumeration value="{93FFEC66-CBC8-4C7F-9C6A-CB1C17A7567D}"/>
    <!--Percentage Sampling-->
    <xs:enumeration value="{05322586-D434-4593-8BE4-8CFC766D9C8B}"/>
    <!--Pivot-->
    <xs:enumeration value="{AEB2AFAE-2201-48B1-B290-42BB8C9149DD}"/>
    <!--RowCount-->
    <xs:enumeration value="{E2697D8C-70DA-42B2-8208-A19CE3A9FE41}"/>
    <!--Row Sampling-->
    <xs:enumeration value="{284A868A-7C3D-498C-ABBF-028CEF6AB288}"/>
    <!--Script Component, ADO.Net source, XML Source,ADO.Net
    Destination, DataReader Destination, SQL ServerCompact Destination-->
    <xs:enumeration value="{874F7595-FB5F-40FF-96AF-FBFF8250E3EF}"/>
    <!--Slowly Changing Dimension-->
    <xs:enumeration value="{25BBB0C5-369B-4303-B3DF-D0DC741DEE58}"/>
    <!--Sort-->
    <xs:enumeration value="{5B1A3FF5-D366-4D75-AD1F-F19A36FCBEDB}"/>
    <!--Term Extraction-->
    <xs:enumeration value="{056F53D1-8081-4D07-8134-1D4DAC244BB2}"/>
    <!--Term Lookup-->
    <xs:enumeration value="{ACCC729A-823D-49A7-B16D-F1999AEB1D4C}"/>
  </xs:restriction>
</xs:simpleType>

```

```

<!--Union All-->
<xs:enumeration value="{B594E9A8-4351-4939-891C-CFE1AB93E925}"/>
<!--Unpivot-->
<xs:enumeration value="{B8B094A9-8809-4E06-8874-5C55606A9FDF}"/>
<!--Destinations-->
<!--Excel Destination-->
<xs:enumeration value="{1F5D5712-2FBA-4CB9-A95A-86C1F336E1DA}"/>
<!--Flat File Destination-->
<xs:enumeration value="{8DA75FED-1B7C-407D-B2AD-2B24209CCCA4}"/>
<!--OLE DB Destination-->
<xs:enumeration value="{4ADA7EAA-136C-4215-8098-D7A7C27FC0D1}"/>
<!--Data Mining Model Training-->
<xs:enumeration value="{3D9FFAE9-B89B-43D9-80C8-B97D2740C746}"/>
<!--Dimension Processing-->
<xs:enumeration value="{2C2F0891-3AAA-4865-A676-D7476FE4CE90}"/>
<!--Partition Processing-->
<xs:enumeration value="{DA510FB7-E3A8-4D96-9F59-55E15E67FE3D}"/>
<!--Raw File-->
<xs:enumeration value="{04762BB6-892F-4EE6-AD46-9CEB0A7EC7A2}"/>
<!--RecordSet Destination-->
<xs:enumeration value="{C457FD7E-CE98-4C4B-AEFE-F3AE0044F181}"/>
<!--SQL Server Destination-->
<xs:enumeration value="{F452EAF3-5EF0-43F1-8067-09DDF0BC6316}"/>
<!--Sources-->
<!--Excel Source-->
<xs:enumeration value="{8C084929-27D1-479F-9641-ABB7CDADF1AC}"/>
<!--Flat File Source-->
<xs:enumeration value="{D23FD76B-F51D-420F-BBCB-19CBF6AC1AB4}"/>
<!--OLE DB Source-->
<xs:enumeration value="{165A526D-D5DE-47FF-96A6-F8274C19826B}"/>
<!--Raw File Source-->
<xs:enumeration value="{480C7D5A-CE63-405C-B338-3C7F26560EE3}"/>
</xs:restriction>
</xs:simpleType>

```

The following table specifies the enumeration values for the **PipelineComponentComponentClassIDEnum** type.

Enumeration value	Description
{5B201335-B360-485C-BB93-75C34E09B3D3}	Aggregate Component
{4FCE8297-9C65-40A9-9D60-00C5CC6BC283}	Audit Component
{BF818E79-2C1C-410D-ADEA-B2D1A04FED01}	Cache Component
{C86C867A-7D40-486A-8734-F0B6943A9DD4}	Character Map Component
{7F88F654-4E20-4D14-84F4-AF9C925D3087}	Conditional Split Component
{D231ABC4-4754-481B-8F7A-CD4BD8D09832}	Copy Column Component

Enumeration value	Description
{62B1106C-7DB8-4EC8-ADD6-4C664DFFC54A}	Data Conversion Component
{CBDFF0CC-3758-4424-A431-3C2E103069AA}	Data Mining Query Component
{49928E82-9C4E-49F0-AABE-3812B82707EC}	Derived Column Component
{A9823821-0085-4483-952F-36277F63FFC5}	Export Column Component
{836E0D0B-0358-45B4-B888-4ADCE9356D4E}	Fuzzy Grouping Component
{E4A5F949-EC93-45AB-8B36-B52936257EC2}	Fuzzy Lookup Component
{9053CAE0-140B-48E4-AEEC-4E6A26E9E436}	Import Column Component
{671046B0-AA63-4C9F-90E4-C06E0B710CE3}	Lookup Component
{36E0E750-2510-4776-AA6E-17EAE84FD63E}	Merge Component
{14D43A4F-D7BD-489D-829E-6DE35750CFE4}	MergeJoin Component
{EC139FBC-694E-490B-8EA7-35690FB0F445}	Multicast Component
{93FFEC66-CBC8-4C7F-9C6A-CB1C17A7567D}	OLE DB Command Component
{05322586-D434-4593-8BE4-8CFC766D9C8B}	Percentage Sampling Component
{AEB2AFAE-2201-48B1-B290-42BB8C9149DD}	Pivot Component
{E2697D8C-70DA-42B2-8208-A19CE3A9FE41}	RowCount Component
{284A868A-7C3D-498C-ABBF-028CEF6AB288}	Row Sampling Component
{874F7595-FB5F-40FF-96AF-FBFF8250E3EF}	Script Component, ADO.NET Source Component, XML Source Component, ADO.NET Destination Component, DataReader Destination Component, and SQL Server Compact Edition Destination Component. <59>
{25BBB0C5-369B-4303-B3DF-D0DC741DEE58}	Slowly Changing Dimension Component
{5B1A3FF5-D366-4D75-AD1F-F19A36FCBEDB}	Sort Component

Enumeration value	Description
{056F53D1-8081-4D07-8134-1D4DAC244BB2}	Term Extraction Component
{ACCC729A-823D-49A7-B16D-F1999AEB1D4C}	Term Lookup Component
{B594E9A8-4351-4939-891C-CFE1AB93E925}	Union All Component
{B8B094A9-8809-4E06-8874-5C55606A9FDF}	Unpivot Component
{2E42D45B-F83C-400F-8D77-61DDE6A7DF29}	ADO.NET Destination Component
{1F5D5712-2FBA-4CB9-A95A-86C1F336E1DA}	Excel Destination Component
{8DA75FED-1B7C-407D-B2AD-2B24209CCCA4}	Flat File Destination Component
{4ADA7EAA-136C-4215-8098-D7A7C27FC0D1}	OLE DB Destination Component
{3D9FFAE9-B89B-43D9-80C8-B97D2740C746}	Data Mining Model Training Destination Component
{2C2F0891-3AAA-4865-A676-D7476FE4CE90}	Dimension Processing Destination Component
{DA510FB7-E3A8-4D96-9F59-55E15E67FE3D}	Partition Processing Destination Component
{C457FD7E-CE98-4C4B-AEFE-F3AE0044F181}	RecordSet Destination Component
{2E42D45B-F83C-400F-8D77-61DDE6A7DF29}	SQL Server Compact Edition Destination Component
{F452EAF3-5EF0-43F1-8067-09DDF0BC6316}	SQL Server Destination Component
{8C084929-27D1-479F-9641-ABB7CDADF1AC}	Excel Source Component
{D23FD76B-F51D-420F-BBCB-19CBF6AC1AB4}	Flat File Source Component
{165A526D-D5DE-47FF-96A6-F8274C19826B}	OLE DB Source Component
{480C7D5A-CE63-405C-B338-3C7F26560EE3}	Raw File Source Component

2.7.1.1.1.1.6 Attribute Groups and Common Types Used by Components

The following sections specify attribute groups and other types that are referenced by type definitions within the Pipeline component's hierarchy of types.

2.7.1.1.1.1.6.1 PipelineComponentMetadataColumnsType

The **PipelineComponentMetadataColumnsType** complex type specifies a collection of external metadata column objects for an **input** element or an **output** element of a Pipeline executable.

The following is the XSD for the **PipelineComponentMetadataColumnsType** complex type.

```
<xs:complexType name="PipelineComponentMetadataColumnsType">
  <xs:sequence>
    <xs:element name="externalMetadataColumn"
      type="DTS:PipelineComponentMetadataColumnType"
      minOccurs="0" maxOccurs="unbounded" form="unqualified"/>
  </xs:sequence>
  <xs:attribute name="isUsed" form="unqualified">
    <xs:simpleType>
      <xs:restriction base="xs:string">
        <xs:enumeration value="True"/>
        <xs:enumeration value="False"/>
      </xs:restriction>
    </xs:simpleType>
  </xs:attribute>
</xs:complexType>
```

The following table specifies the elements of the **PipelineComponentMetadataColumnsType** complex type.

Element	Type definition	Description
externalMetadataColumn	PipelineComponentMetadataColumnType	A complex type that specifies a single metadata column definition within an input or an output of a Pipeline.

The following table specifies the attributes of the **PipelineComponentExternalMetadataColumnsType** complex type.

Attribute group	Description
isUsed	An enumeration value that specifies whether external metadata columns are used. "True" specifies that external metadata columns are used. "False" specifies that external metadata columns are not used.

2.7.1.1.1.1.6.1.1 PipelineComponentMetadataColumnType

The **PipelineComponentMetadataColumnType** complex type specifies a single column that is a member of a collection of metadata columns that are part of a Pipeline component.

The following is the XSD for the **PipelineComponentMetadataColumnType** complex type.

```

<xs:complexType name="PipelineComponentMetadataColumnType">
  <xs:sequence>
    <xs:element name="properties"
      type="DTS:PipelineComponentMetadataColumnPropertiesType"
      minOccurs="0" form="unqualified"/>
  </xs:sequence>
  <xs:attributeGroup
    ref="DTS:PipelineComponentAllColumnBaseAttributeGroup"/>
  <xs:attributeGroup
    ref="DTS:PipelineComponentColumnExtendedAttributeGroup"/>
</xs:complexType>

```

The following table specifies the elements of the **PipelineComponentMetadataColumnType** complex type.

Element	Type definition	Description
properties	PipelineComponentMetadataColumnPropertiesType	A complex type that specifies a collection of properties of a metadata column.

The following table specifies the attribute groups of the **PipelineComponentMetadataColumnType** type.

Attribute group	Description
PipelineComponentAllColumnBaseAttributeGroup	An attribute group specification that specifies attributes that are common to all types of columns for Pipeline components.
PipelineComponentColumnExtendedAttributeGroup	An attribute group specification that specifies additional attributes that are present for the PipelineComponentMetadataColumnType type.

2.7.1.1.1.1.6.1.1.1 PipelineComponentMetadataColumnPropertiesType

The **PipelineComponentMetadataColumnPropertiesType** complex type specifies a collection of properties for an **externalMetadataColumn** element that is part of a Pipeline component.

The following is the XSD for the **PipelineComponentMetadataColumnPropertiesType** complex type.

```

<xs:complexType name="PipelineComponentMetadataColumnPropertiesType">
  <xs:sequence>
    <xs:element name="property"
      type="DTS:PipelineComponentMetadataColumnPropertyType"
      minOccurs="0" maxOccurs="unbounded" form="unqualified"/>
  </xs:sequence>
</xs:complexType>

```

The following table specifies the elements of the **PipelineComponentMetadataColumnPropertiesType** complex type.

Element	Type definition	Description
property	PipelineComponentMetadataColumnPropertyType	A complex type that specifies a single property within a collection of metadata column properties for an externalMetadataColumn element of a Pipeline component.

2.7.1.1.1.1.6.1.1.1.1 PipelineComponentMetadataColumnPropertyType

The **PipelineComponentMetadataColumnPropertyType** complex type specifies a property of an **inputColumn** element.

The following is the XSD for the **PipelineComponentMetadataColumnPropertyType** complex type.

```
<xs:complexType name="PipelineComponentMetadataColumnPropertyType">
  <xs:simpleContent>
    <xs:extension base="xs:anySimpleType">
      <xs:attributeGroup
        ref="DTS:PipelineComponentPropertyAttributeGroup"/>
      <xs:attribute name="name" form="unqualified" use="required"
        type="DTS:PipelineComponentMetadataColumnPropertyNameEnum"/>
    </xs:extension>
  </xs:simpleContent>
</xs:complexType>
```

The following table specifies the attributes and attribute groups of the **PipelineComponentMetadataColumnPropertyType** complex type.

Attribute	Description
PipelineComponentPropertyAttributeGroup	An attribute group that contains attributes that are common to all property elements for input elements, output elements, inputColumn elements, and outputColumn elements.
name	A string value that specifies the name of the property.

2.7.1.1.1.1.6.1.1.1.1.1 PipelineComponentMetadataColumnPropertyNameEnum

The **PipelineComponentMetadataColumnPropertyNameEnum** type contains the allowed values for the **name** attribute on the **externalMetadataColumn** element of a Pipeline component. The allowed values for the **property** element for each task are more restricted than the values that are specified formally by the XSD.

Each **name** attribute value MUST NOT be used for any component except for the components that are specified in the subsections to this section. Some components allow no properties.

The additional restrictions specified in the subsections to this section MUST be followed for the **name** attribute on the **property** element children of the **externalMetadataColumn** element.

The following is the XSD of the **PipelineComponentMetadataColumnPropertyNameEnum** type.

```

<xs:simpleType name="PipelineComponentMetadataColumnNameEnum">
  <xs:restriction base="xs:string">
    <!--OLE DB Command-->
    <xs:enumeration value="DBParamInfoFlags"/>
    <!--XML Source-->
    <xs:enumeration value="CLRType"/>
  </xs:restriction>
</xs:simpleType>

```

2.7.1.1.1.6.1.1.1.2 OLE DB Command Component

The OLE DB Command Component **externalMetadataColumn** element MUST NOT use any **Name** attribute value on a child **property** element except for those that are listed in the table in this section.

The following table specifies the **Name** attribute values that are allowed for the OLE DB Command Component on the **externalMetadataColumn** element, in addition to any restrictions on the element value. These restrictions MUST be followed.

Name attribute value	Description
DBParamInfoFlags	<p>The property element value MUST be an integer. This integer is a bitmask that specifies characteristics of a parameter. The interpretation of the bits in the bitmask is as follows:</p> <ul style="list-style-type: none"> 0x00000001 – The parameter accepts values on input. 0x00000002 – The parameter returns values on output. 0x00000010 – The parameter is signed. 0x00000040 – The parameter accepts NULL values. 0x00000080 – The parameter is a binary large object (BLOB). 0x00000100 – The parameter value represents the absolute value of the negative scale of the parameter.

2.7.1.1.1.6.1.1.1.3 XML Source Component

The XML Source Component **externalMetadataColumn** element MUST NOT use any **Name** attribute value on a child **property** element except for those that are listed in the table in this section.

The following table specifies the **Name** attribute values that are allowed for the XML Source Component on the **externalMetadataColumn** element, in addition to any restrictions on the element value. These restrictions MUST be followed.

Name attribute value	Description
CLRType	<p>The property element value MUST be a string. This value specifies the type of the column, in terms of the CLR type system. The allowed string values are the following:</p> <ul style="list-style-type: none"> System.Boolean – Boolean. System.Byte – Byte.

Name attribute value	Description
	System.SByte – 8-bit signed integer. System.Char – Unicode character. System.Decimal – Decimal number. System.Double – Double-precision real number. System.Single – Single-precision real number. System.Int32 – 32-bit integer. System.UInt32 – Unsigned 32-bit integer. System.Int64 – 64-bit integer. System.UInt64 – Unsigned 64-bit integer. System.Object – Object. System.Int16 – 16-bit integer. System.UInt16 – Unsigned 16-bit integer. System.String – Unicode character string. For more information about Microsoft® .NET Framework system types, see [MSDN-TYPCLS] .

2.7.1.1.1.1.6.2 PipelineComponentInputOutputElementAttributeGroup

The **PipelineComponentInputOutputElementAttributeGroup** attribute group specifies attributes that are used in common by the **input** element and the **output** element of the Pipeline component.

The following is the XSD for the **PipelineComponentInputOutputElementAttributeGroup** attribute group.

```

<xs:attributeGroup
  name="PipelineComponentInputOutputElementAttributeGroup">
  <xs:attribute name="refId" type="xs:string" use="required"
    form="unqualified"/>
  <xs:attribute name="name" type="xs:string" use="optional" default=""
    form="unqualified"/>
  <xs:attribute name="description" type="xs:string"
    use="optional" default="" form="unqualified"/>
  <xs:attribute name="hasSideEffects" type="xs:boolean"
    use="optional" default="false" form="unqualified"/>
  <xs:attribute name="dangling" type="xs:boolean"
    use="optional" default="false" form="unqualified"/>
  <xs:attribute name="errorOrTruncationOperation" type="xs:string"
    use="optional" default="" form="unqualified"/>
  <xs:attribute name="errorRowDisposition" form="unqualified"
    type="DTS:PipelineComponentRowDispositionEnum"
    use="optional" default="NotUsed"/>
  <xs:attribute name="truncationRowDisposition" form="unqualified"
    type="DTS:PipelineComponentRowDispositionEnum"
    use="optional" default="NotUsed"/>
</xs:attributeGroup>

```

The following table specifies additional information for the attributes of the **PipelineComponentInputOutputElementAttributeGroup** attribute group.

Attribute group	Description
refId	A string value that specifies a unique refId for this object. Elsewhere within the containing executable or within the package, the value of refId can be used to refer to this object. <60>
Name	A string value that specifies the name for this column element.
description	A string value that specifies the description for this component output element.
hasSideEffects	A Boolean value that indicates whether a component can be removed from the execution plan of the data flow when it is not attached to an upstream component and when the value of the RunInOptimizedMode attribute is TRUE. TRUE indicates that the component cannot be removed from the execution plan when it is not attached to an upstream component and when the RunInOptimizedMode attribute of the Pipeline element is TRUE. FALSE indicates that the component can be removed from the execution plan when it is not attached to an upstream component and when the RunInOptimizedMode attribute of the Pipeline element is TRUE.
dangling	A Boolean value that specifies whether the output is dangling, that is, that it does not lead to another component. TRUE specifies that the output is dangling. FALSE specifies that the output is not dangling.
errorOrTruncationOperation	A string value that specifies a string that can be displayed by the user interface to indicate the type of operation that causes an error or truncation operation to occur.
errorRowDisposition	An enumeration value that specifies the handling of row errors.
TruncationRowDisposition	An enumeration value that specifies the handling of truncations that occur when processing rows.

2.7.1.1.1.6.3 PipelineComponentAllColumnBaseAttributeGroup

The **PipelineComponentAllColumnBaseAttributeGroup** attribute group specifies the attributes that are used for all columns that are specified by components.

The following is the XSD for the **PipelineComponentAllColumnBaseAttributeGroup** attribute group.

```
<xs:attributeGroup name="PipelineComponentAllColumnBaseAttributeGroup">
  <xs:attribute name="refId" type="xs:string" use="required"
    form="unqualified"/>
  <xs:attribute name="name" type="xs:string" use="optional" default=""
    form="unqualified"/>
  <xs:attribute name="description" type="xs:string" use="optional"
    default="" form="unqualified"/>
  <xs:attribute name="mappedColumnId" type="xs:int" use="optional"
    default="0" form="unqualified"/>
</xs:attributeGroup>
```

The following table specifies additional information for the attributes of the **PipelineComponentAllColumnBaseAttributeGroup** attribute group.

Attribute group	Description
refId	A string value that specifies a unique refId for this object. Elsewhere within the containing executable or within the package, the value of refId can be used to refer to this object. <61>
name	A string value that specifies the name for this column element.
description	A string value that specifies the description for this column element.
mappedColumnId	An integer value that specifies the id of a column that is mapped to this column.

2.7.1.1.1.6.4 PipelineComponentIOColumnBaseAttributeGroup

The **PipelineComponentIOColumnBaseAttributeGroup** attribute group specifies the attributes that are used for all columns that serve as input columns or output columns that are specified by components.

The following is the XSD for the **PipelineComponentIOColumnBaseAttributeGroup** attribute group.

```
<xs:attributeGroup name="PipelineComponentIOColumnBaseAttributeGroup">
  <xs:attribute name="errorOrTruncationOperation" type="xs:string"
    use="optional" default="" form="unqualified"/>
  <xs:attribute name="errorRowDisposition"
    type="DTS:PipelineComponentRowDispositionEnum"
    form="unqualified" use="optional" default="NotUsed"/>
  <xs:attribute name="truncationRowDisposition"
    type="DTS:PipelineComponentRowDispositionEnum"
    form="unqualified" use="optional" default="NotUsed"/>
  <xs:attribute name="externalMetadataColumnId" type="xs:string"
    form="unqualified"/>
  <xs:attribute name="lineageId" type="xs:string" use="required"
    form="unqualified"/>
</xs:attributeGroup>
```

The following table specifies additional information for the attributes of the **PipelineComponentIOColumnBaseAttributeGroup** attribute group.

Attribute group	Description
errorOrTruncationOperation	A string value that specifies a string that can be displayed by the user interface to indicate the type of operation that causes an error or truncation operation to occur.
errorRowDisposition	An enumeration value that specifies the handling of row errors.
truncationRowDisposition	An enumeration value that specifies the handling of truncations that occur when processing rows.
externalMetadataColumnId	An integer value that specifies the id of the external metadata column for this column.

Attribute group	Description
lineageId	A string value. <62>

2.7.1.1.1.6.5 PipelineComponentColumnExtendedAttributeGroup

The **PipelineComponentColumnExtendedAttributeGroup** attribute group specifies additional attributes that are used for some columns that are specified within components.

The following is the XSD for the **PipelineComponentColumnExtendedAttributeGroup** attribute group.

```
<xs:attributeGroup name="PipelineComponentColumnExtendedAttributeGroup">
  <xs:attribute name="precision" type="xs:int" use="optional" default="0"
    form="unqualified"/>
  <xs:attribute name="scale" type="xs:int" use="optional" default="0"
    form="unqualified"/>
  <xs:attribute name="length" type="xs:int" use="optional" default="0"
    form="unqualified"/>
  <xs:attribute name="dataType"
    type="DTS:PipelineComponentColumnDataTypeEnum"
    use="optional" default="empty" form="unqualified"/>
  <xs:attribute name="codePage" type="xs:int" use="optional" default="0"
    form="unqualified"/>
</xs:attributeGroup>
```

The following table specifies additional information for the attributes of the **PipelineComponentColumnExtendedAttributeGroup** attribute group.

Attribute	Description
Precision	An integer value that specifies the total digits in a numeric data type.
Scale	An integer value that specifies the number of digits to the right of the decimal point.
Length	An integer value that specifies the length of the column in characters.
dataType	An enumeration value that specifies the type of the data in the column.
Codepage	An integer value that specifies the numeric value of the ANSI code page that is used for strings for this column.

2.7.1.1.1.6.5.1 PipelineComponentColumnDataTypeEnum

The **PipelineComponentColumnDataTypeEnum** type contains the enumeration values for the **DataType** attribute as it appears within the different types of column elements.

The following is the XSD for the **PipelineComponentColumnDataTypeEnum** type.

```
<xs:simpleType name="PipelineComponentColumnDataTypeEnum">
  <xs:restriction base="xs:string">
    <xs:enumeration value="empty"/>
    <xs:enumeration value="i1"/>
  </xs:restriction>
</xs:simpleType>
```

```

<xs:enumeration value="ui1"/>
<xs:enumeration value="i2"/>
<xs:enumeration value="i4"/>
<xs:enumeration value="r4"/>
<xs:enumeration value="r8"/>
<xs:enumeration value="cy"/>
<xs:enumeration value="date"/>
<xs:enumeration value="bool"/>
<xs:enumeration value="variant"/>
<xs:enumeration value="decimal"/>
<xs:enumeration value="ui2"/>
<xs:enumeration value="ui4"/>
<xs:enumeration value="i8"/>
<xs:enumeration value="ui8"/>
<xs:enumeration value="guid"/>
<xs:enumeration value="bytes"/>
<xs:enumeration value="str"/>
<xs:enumeration value="wstr"/>
<xs:enumeration value="numeric"/>
<xs:enumeration value="dbDate"/>
<xs:enumeration value="dateTime"/>
<xs:enumeration value="dbTime"/>
<xs:enumeration value="dbTimeStamp"/>
<xs:enumeration value="image"/>
<xs:enumeration value="text"/>
<xs:enumeration value="nText"/>
<xs:enumeration value="dbTime2"/>
<xs:enumeration value="dbTimeStamp2"/>
<xs:enumeration value="dbTimeStampOffset"/>
</xs:restriction>
</xs:simpleType>

```

The following table specifies the enumeration values for the **PipelineComponentColumnDataTypeEnum** type.

Enumeration value	Description
empty	Empty value.
i1	One-byte integer.
ui1	One-byte unsigned integer.
i2	Two-byte integer.
i4	Four-byte integer.
r4	Four-byte real number.
r8	Eight-byte real number.
cy	Calendar year.
date	Date.
bool	Boolean.
variant	Variant.

Enumeration value	Description
decimal	Decimal value.
ui2	Two-byte unsigned integer.
ui4	Four-byte unsigned integer.
i8	Eight-byte integer.
ui8	Eight-byte unsigned integer.
guid	GUID.
bytes	Bytes.
str	Null-terminated ANSI character string with maximum length of 8000 characters.
wstr	Null-terminated Unicode character string with maximum length of 8000 characters.
numeric	Numeric.
dbDate	A structure that consists of year, month, day.
dateTime	Date time.
dbTime	A structure that consists of hour, minute, second.
dbTimeStamp	A structure that consists of year, month, day, hour, minute, seconds, and fractional parts.
image	Image.
text	Text.
nText	A Unicode character string with a maximum length of $2^{30} - 1$ characters.
dbTime2	A dbtime type that also includes fractional seconds.
dbTimeStamp2	A dbTimeStamp type that also includes fractional seconds.
dbTimeStampOffset	A dbTimeStamp type that has a time zone offset.

2.7.1.1.1.1.6.6 PipelineComponentPropertyAttributeGroup

The **PipelineComponentPropertyAttributeGroup** attribute group specifies the attributes that are used for all input and output columns that are specified by components.

The following is the XSD for the **PipelineComponentPropertyAttributeGroup** attribute group.

```
<xs:attributeGroup
  name="PipelineComponentPropertyAttributeGroup">
  <xs:attribute name="dataType"
    type="DTS:PipelineComponentDataTypeEnum"
    form="unqualified"/>
  <xs:attribute name="state"
    type="DTS:PipelineComponentStateEnum"/>
```

```

        form="unqualified" use="optional" default="default" />
<xs:attribute name="isArray" type="xs:boolean"
    use="optional" default="false" form="unqualified"/>
<xs:attribute name="description" type="xs:string"
    use="optional" default="" form="unqualified"/>
<xs:attribute name="typeConverter" type="xs:string"
    use="optional" default="" form="unqualified"/>
<xs:attribute name="UITypeEditor" type="xs:string"
    use="optional" default="" form="unqualified"/>
<xs:attribute name="containsID" type="xs:boolean"
    use="optional" default="false" form="unqualified"/>
<xs:attribute name="expressionType"
    type="DTS:PipelineComponentExpressionTypeEnum"
    use="optional" default="None" form="unqualified"/>
</xs:attributeGroup>

```

The following table specifies additional information for the attributes of the **PipelineComponentPropertyAttributeGroup** attribute group.

Attribute group	Description
name	A string value that specifies the name for this component property element.
dataType	An enumeration value that specifies the data type that is contained in the value for the property element.
state	An enumeration value that specifies the manner in which the property value is serialized.
isArray	A Boolean value that specifies whether the value of the property element is an array. TRUE specifies that the value of the property element is an array. FALSE specifies that the value of the property element is not an array.
description	A string value that specifies the description for this component property element.
typeConverter	A string value that specifies the class name of a class that inherits from System.ComponentModel.TypeConverter . This class can be called to do type conversion from this component property type to another type.
UITypeEditor	A string value that specifies the class name of a class that derives from System.Drawing.Design.UITypeEditor and can be called by a user interface to edit a component property.
containsID	A Boolean value that specifies whether this property value is a reference to a column. TRUE specifies that this property value is a reference to a column. FALSE specifies that this property value is not a reference to a column.
expressionType	An enumeration value that specifies whether the value for the property can be specified through an expression.

2.7.1.1.2 PipelinePathsType

The **PipelinePathsType** complex type specifies a collection of path objects for the Pipeline executable.

The following is the XSD for the **PipelinePathsType** complex type.

```

<xs:complexType name="PipelinePathsType">
  <xs:sequence>
    <xs:element name="path" type="DTS:PipelinePathType"
      form="unqualified" minOccurs="0" maxOccurs="unbounded"/>
  </xs:sequence>
</xs:complexType>

```

The following table specifies the elements of the **PipelinePathsType** complex type.

Element	Type definition	Description
path	PipelinePathType	A complex type that specifies a single path within a pipeline.

2.7.1.1.2.1 PipelinePathType

The **PipelinePathType** complex type specifies a single path between two components of a Pipeline executable.

The following is the XSD for the **PipelinePathType** complex type.

```

<xs:complexType name="PipelinePathType">
  <xs:sequence/>
  <xs:attribute name="refId" type="xs:string" use="required"
    form="unqualified"/>
  <xs:attribute name="name" type="xs:string" form="unqualified"/>
  <xs:attribute name="description" type="xs:string"
    form="unqualified"/>
  <xs:attribute name="startId" type="xs:string" form="unqualified"/>
  <xs:attribute name="endId" type="xs:string" form="unqualified"/>
</xs:complexType>

```

The following table specifies the attributes of the **PipelinePathType** complex type.

Attribute	Description
refId	A string value that specifies a unique refId for this object. Elsewhere within the containing executable or within the package, the value of refId can be used to refer to this object. <63>
id	An integer value that specifies an identifier for this path element. Other elements can refer to this path element by using this id value.
name	A string value that specifies the name for this path element.
description	A string value that specifies the description for this path element.
startId	A string value that specifies the identifier for a component that is where the path that this path element describes starts.
endId	A string value that specifies the identifier for a component that is where the path that this path element describes ends.

2.7.1.2 ActiveXScriptTaskData Element

The **ActiveXScriptTaskData** element is used to specify parameters, properties, and settings that are specific to the ActiveX Script Task. The **ActiveXScriptTaskData** element resides in the [ActiveXScriptTask](#) namespace. The [ExecutableObjectDataType](#) type refers to the **ActiveXScriptTaskData** element within an XSD **choice** element by using the XSD **ref** attribute, as in the following XSD fragment.

```
<xs:element ref="ActiveXScriptTask:ActiveXScriptTaskData" />
```

2.7.1.2.1 ActiveXScriptTask Namespace

The **ActiveXScriptTask** namespace specifies elements and types that are used by the ActiveX Script Task.

The following is the XSD declaration for the **ActiveXScriptTask** namespace.

```
xmlns:ActiveXScriptTask=  
"www.microsoft.com/sqlserver/dts/tasks/activexscripttask"
```

2.7.1.2.1.1 ActiveXScriptTaskData Element

The **ActiveXScriptTaskData** element is used to specify parameters, properties, and settings that are specific to the ActiveX Script Task.

The following is the XSD for element declaration for the **ActiveXScriptTaskData** element in the [ActiveXScriptTask](#) namespace.

```
<xs:element name="ActiveXScriptTaskData"  
            type="ActiveXScriptTask:ActiveXScriptTaskDataType"/>
```

2.7.1.2.1.1.1 ActiveXScriptTaskDataType

The **ActiveXScriptTaskDataType** complex type holds parameters, properties, and settings for an ActiveX Script Task.

The following is the XSD for the **ActiveXScriptTaskDataType** complex type.

```
<xs:complexType name="ActiveXScriptTaskDataType">  
  <xs:sequence/>  
  <xs:attribute name="ScriptingLanguage"  
                type="ActiveXScriptTask:ScriptingLanguageEnum"/>  
  <xs:attribute name="ScriptText" type="xs:string"/>  
  <xs:attribute name="EntryMethod" type="xs:string"/>  
</xs:complexType>
```

The **ActiveXScriptTaskDataType** complex type MUST NOT contain any elements or values.

The following table provides additional information for the attributes of the **ActiveXScriptTaskDataType** complex type.

Attribute	Description
ScriptingLanguage	This enumeration value specifies the language the script is written in.
ScriptText	This string value contains the software code for the script in the language that is indicated by the ScriptingLanguage attribute.
EntryMethod	This string value specifies the name of the method where the script is entered.

2.7.1.2.1.1.1 ScriptingLanguageEnum

The **ScriptingLanguageEnum** type contains the enumeration values for the **ScriptingLanguage** attribute.

The following is the XSD for the **ScriptingLanguageEnum** type.

```
<xs:simpleType name="ScriptingLanguageEnum">
  <xs:restriction base="xs:string">
    <xs:enumeration value="VBScript"/>
    <xs:enumeration value="JScript.Compact"/>
    <xs:enumeration value="JScript"/>
  </xs:restriction>
</xs:simpleType>
```

The following table specifies the enumeration values for the **ScriptingLanguageEnum** type.

Enumeration value	Description
VBScript	Visual Basic Script language [MSDN-VBSLR] .
JScript.Compact	Java Script Compact EMCA 327 [ECMA-327] .
Jscript	Java Script language [JavaSpec] .

2.7.1.3 ASDdlDataObjectDataType

The **ASDdlDataObjectDataType** complex type is used to specify parameters, properties, and settings that are specific to the Analysis Services (AS) Execute Data Definition Language (DDL) Task.

The following is the XSD for the **ASDdlDataObjectDataType** complex type.

```
<xs:complexType name="ASDdlDataObjectDataType">
  <xs:sequence/>
  <xs:attribute name="ConnectionName" type="xs:string"
    form="unqualified"/>
  <xs:attribute name="SourceType" form="unqualified"
    type="DTS:SourceTypeEnum"/>
  <xs:attribute name="Source" type="xs:string"
    form="unqualified"/>
```



```
</xs:complexType>
```

The **ASDdlDataObjectDataType** complex type MUST NOT contain any elements or values.

The following table specifies the attributes of the **ASDdlDataObjectDataType** complex type.

Attribute	Description
ConnectionName	The name of a connection manager that connects to an instance of Microsoft® SQL Server® Analysis Services or to an Analysis Services project.
SourceType	Specifies the source of the DDL statements.
Source	If the SourceType is "variable", this string contains the name of the variable that contains the DDL statements that the task executes. If the SourceType is "DirectInput", this string contains the text of the DDL statement as encoded XML. If the SourceType is "FileConnection", this string contains the value of the ObjectName property of a connection manager.

2.7.1.4 ASProcessingDataObjectDataType

The **ASProcessingDataObjectDataType** complex type is used to specify parameters, properties, and settings that are specific to the AS Processing Task.

The following is the XSD for the **ASProcessingDataObjectDataType** complex type.

```
<xs:complexType name="ASProcessingDataObjectDataType">
  <xs:sequence/>
  <xs:attribute name="ConnectionName" type="xs:string"
    form="unqualified"/>
  <xs:attribute name="ProcessingCommands" type="xs:string"
    form="unqualified"/>
</xs:complexType>
```

The **ASProcessingDataObjectDataType** type MUST NOT contain any elements or values.

The following table provides additional information about the attributes of the **ASProcessingDataObjectDataType** type.

Attribute	Description
ConnectionName	This string contains the name of a ConnectionManager that is available in this package. The ConnectionName attribute is matched to the ObjectName property of the ConnectionManager type.
ProcessingCommands	This string contains a stream of encoded XML that contains the actual processing commands that are to be executed.

2.7.1.5 BulkInsertTaskData Element

The **BulkInsertTaskData** element is used to specify parameters, properties, and settings that are specific to the Bulk Insert Task. The **BulkInsertTaskData** element resides in the [BulkInsertTask](#)

namespace. The **BulkInsertTaskData** type refers to the **BulkInsertTaskData** element within an XSD **choice** element, using the XSD **ref** attribute, as in the following XSD fragment.

The following is the XSD for the **BulkInsertTaskData** element.

```
<xs:element ref="BulkInsertTask:BulkInsertTaskData"/>
```

For more information about the **BulkInsertTaskData** element, see [ExecutableObjectDataType](#).

2.7.1.5.1 BulkInsertTask Namespace

The **BulkInsertTask** namespace specifies the elements and types that are used by the Bulk Insert Task.

The following is the XSD declaration for the **BulkInsertTask** namespace.

```
xmlns:BulkInsertTask=  
"www.microsoft.com/sqlserver/dts/tasks/bulkinserttask"
```

2.7.1.5.1.1 BulkInsertTaskData Element

The **BulkInsertTaskData** element is used to specify parameters, properties, and settings that are specific to the Bulk Insert Task.

The following is the XSD for the element declaration for the **BulkInsertTaskData** element in the [BulkInsertTask](#) namespace.

```
<xs:element name="BulkInsertTaskData"  
  type="BulkInsertTask:BulkInsertTaskDataType"/>
```

2.7.1.5.1.2 BulkInsertTaskDataType

The **BulkInsertTaskDataType** complex type holds parameters, properties, and settings for a Bulk Insert Task.

The following is the XSD for the **BulkInsertTaskDataType** complex type.

```
<xs:complexType name="BulkInsertTaskDataType">  
  <xs:sequence/>  
  <xs:attribute name="BatchSize" type="xs:int" use="optional"  
    default="0"/>  
  <xs:attribute name="CheckConstraints" use="optional" default="True">  
    <xs:simpleType>  
      <xs:restriction base="xs:string">  
        <xs:enumeration value="True"/>  
        <xs:enumeration value="False"/>  
      </xs:restriction>  
    </xs:simpleType>  
  </xs:attribute>
```

```

<xs:attribute name="CodePage" type="BulkInsertTask:CodePageType"
  use="optional" default="RAW"/>
<xs:attribute name="SourceConnectionName" type="xs:string"
  use="optional" default=""/>
<xs:attribute name="DestinationConnectionName" type="xs:string"
  use="optional" default=""/>
<xs:attribute name="DataFileType"
  type="BulkInsertTask:DataFileTypeEnum"
  use="optional" default="DTSBulkInsert_DataFileType_Char"/>
<xs:attribute name="DestinationTableName" type="xs:string"
  use="optional" default=""/>
<xs:attribute name="FirstRow" type="xs:int" use="optional"
  default="1"/>
<xs:attribute name="LastRow" type="xs:int" use="optional"
  default="0"/>
<xs:attribute name="UseFormatFile" use="optional" default="False">
  <xs:simpleType>
    <xs:restriction base="xs:string">
      <xs:enumeration value="True"/>
      <xs:enumeration value="False"/>
    </xs:restriction>
  </xs:simpleType>
</xs:attribute>
<xs:attribute name="FormatFile" type="xs:string" use="optional"
  default=""/>
<xs:attribute name="SortedData" type="xs:string" use="optional"
  default=""/>
<xs:attribute name="TableLock" use="optional" default="False">
  <xs:simpleType>
    <xs:restriction base="xs:string">
      <xs:enumeration value="True"/>
      <xs:enumeration value="False"/>
    </xs:restriction>
  </xs:simpleType>
</xs:attribute>
<xs:attribute name="KeepIdentity" use="optional" default="False">
  <xs:simpleType>
    <xs:restriction base="xs:string">
      <xs:enumeration value="True"/>
      <xs:enumeration value="False"/>
    </xs:restriction>
  </xs:simpleType>
</xs:attribute>
<xs:attribute name="KeepNulls" use="optional" default="False">
  <xs:simpleType>
    <xs:restriction base="xs:string">
      <xs:enumeration value="True"/>
      <xs:enumeration value="False"/>
    </xs:restriction>
  </xs:simpleType>
</xs:attribute>
<xs:attribute name="FieldTerminator"
  type="BulkInsertTask:BulkInsertTaskTerminatorEnum"
  use="optional" default="Tab"/>
<xs:attribute name="RowTerminator"
  type="BulkInsertTask:BulkInsertTaskTerminatorEnum"
  use="optional" default="{CR}{LF}"/>
<xs:attribute name="FireTriggers" use="optional" default="False">
  <xs:simpleType>

```

```

    <xs:restriction base="xs:string">
      <xs:enumeration value="True"/>
      <xs:enumeration value="False"/>
    </xs:restriction>
  </xs:simpleType>
</xs:attribute>
<xs:attribute name="MaximumErrors" type="xs:int" use="optional"
  default="0"/>
</xs:complexType>

```

The **BulkInsertTaskDataType** complex type MUST NOT contain elements or values.

The following table specifies additional information for the attributes of the **BulkInsertTaskDataType** complex type.

Attribute	Description
BatchSize	This integer specifies the number of rows in a batch. Each batch is processed as a single transaction. <64>
CheckConstraints	This enumeration value specifies whether constraints on the table are checked during the bulk insert operation. "True" specifies that constraints are checked. "False" specifies that constraints are not checked.
CodePage	This value specifies the code page of the data in the data file.
SourceConnectionName	This string specifies the name of the source connection file.
DestinationConnectionName	This string specifies the name of the connection to the destination database.
DataFileType	This enumeration value specifies the type of text that is in the file.
DestinationTableName	This string specifies the name of the table in the destination database.
FirstRow	The row in the data file at which insertion begins.
LastRow	The row in the data file at which insertion ends. <65>
UseFormatFile	This enumeration value specifies whether a format file is used for the bulk insert operation. "True" specifies that a format file is used for the bulk insert operation. "False" specifies that a format file is not used for the bulk insert operation.
FormatFile	The string specifies the name of the format file. This string is used only when the UseFormatFile attribute is set to "True".
SortedData	This string specifies the columns on which to sort the data.
TableLock	This enumeration value specifies whether a table level lock is acquired for the bulk insert operation. "True" specifies that a table level lock is acquired for the bulk insert operation. "False" specifies that a table level lock is not acquired for the bulk insert

Attribute	Description
	operation.
KeepIdentity	This enumeration value specifies whether to keep data values from the data file for values for identity columns. "True" specifies that values present in the data file are kept for identity columns. "False" specifies that values present in the data file are not kept for identity columns.
KeepNulls	This enumeration value specifies whether null values in the input are retained. "True" specifies that null values in the input are retained. "False" specifies that a default value is used if a null value is encountered in the input.
FieldTerminator	This enumeration value specifies the character that terminates a field.
RowTerminator	This enumeration value specifies the character that terminates a row.
FireTriggers	This enumeration value specifies whether insert triggers that are specified for the table are fired during the bulk insert operation. "True" specifies that triggers are fired during the bulk insert operation. "False" specifies that triggers are not fired during the bulk insert operation.
MaximumErrors	This enumeration value specifies the maximum number of errors allowed.

2.7.1.5.1.2.1 DataFileTypeEnum

The **DataFileTypeEnum** type contains the enumeration values for the **DataFileType** attribute.

The following is the XSD for the **DataFileTypeEnum** type.

```
<xs:simpleType name="DataFileTypeEnum">
  <xs:restriction base="xs:string">
    <xs:enumeration value="DTSBulkInsert_DataFileType_Char"/>
    <xs:enumeration value="DTSBulkInsert_DataFileType_Native"/>
    <xs:enumeration value="DTSBulkInsert_DataFileType_WideChar"/>
    <xs:enumeration value="DTSBulkInsert_DataFileType_WideNative"/>
  </xs:restriction>
</xs:simpleType>
```

The following table specifies the enumeration values for the **DataFileTypeEnum** type.

Enumeration value	Description
DTS_BulkInsert_DataFileType_Char	This enumeration value specifies that the data file contains character data.
DTS_BulkInsert_DataFileType_Native	This enumeration value performs the bulk copy by using character types that are native to the database. <66>

Enumeration value	Description
DTS_BulkInsert_DataFileType_WideChar	This enumeration value specifies that the data file contains Unicode [UNICODE] characters.
DTS_BulkInsert_DataFileType_NativeWide	This enumeration value functions the same as DTS_BulkInsert_DataFileType_Native , except that columns of type char , varchar , and text are stored as Unicode. <67>

2.7.1.5.1.2.2 CodePageType

The **CodePageType** type is used to specify the value of the code page of the data in the data file.

The following is the XSD for the **CodePageType** type.

```
<xs:simpleType name="CodePageType">
  <xs:union memberTypes="xs:int">
    <xs:simpleType>
      <xs:restriction base="xs:string">
        <xs:enumeration value="ACP"/>
        <xs:enumeration value="OEM"/>
        <xs:enumeration value="RAW"/>
      </xs:restriction>
    </xs:simpleType>
  </xs:union>
</xs:simpleType>
```

The **CodePageType** type is a union that allows an integer value or a value from a string enumeration. If the value is an integer, it represents the ANSI code page. If the value is a string enumeration value, it is one of the values in the following table.

Enumeration value	Description
ACP	Columns of char , varchar , or text data type SHOULD be converted from the ANSI code page (ISO 1252 [ISO/IEC-8859-1]) to the server code page. <68>
OEM	Columns of char , varchar , or text data type SHOULD be converted from the system OEM code page to the server code page. <69>
RAW	No conversion from one code page to another occurs.

2.7.1.5.1.2.3 BulkInsertTaskTerminatorEnum

The **BulkInsertTaskTerminatorEnum** type contains the enumeration values that can be specified for the demarcation of fields or records in the input data file.

The following is the XSD for the **BulkInsertTaskTerminatorEnum** type.

```
<xs:simpleType name="BulkInsertTaskTerminatorEnum">
  <xs:restriction base="xs:string">
    <xs:enumeration value="{CR}{LF}"/>
  </xs:restriction>
</xs:simpleType>
```

```

<xs:enumeration value="{CR}"/>
<xs:enumeration value="{LF}"/>
<xs:enumeration value="Semicolon {;}"/>
<xs:enumeration value="Comma {,}"/>
<xs:enumeration value="Tab"/>
<xs:enumeration value="Vertical Bar {|}"/>
</xs:restriction>
</xs:simpleType>

```

The following table specifies the enumeration values for the **BulkInsertTaskTerminatorEnum** type.

Enumeration value	Description
{CR}{LF}	Specifies that the terminator is a carriage return character followed by a line feed character.
{CR}	Specifies that the terminator is a carriage return character.
{LF}	Specifies that the terminator is a line feed character.
Semicolon {;}	Specifies that the terminator is a semicolon character.
Comma {,}	Specifies that the terminator is a comma character.
Tab	Specifies that the terminator is a tab character.
Vertical Bar { }	Specifies that the terminator is a vertical bar character.

2.7.1.6 DMQueryTaskDataObjectType

The **DMQueryTaskDataObjectType** complex type is used to specify parameters, properties, and settings that are specific to the Data Mining Query Task.

The following is the XSD for the **DMQueryTaskDataObjectType** complex type.

```

<xs:complexType name="DMQueryTaskDataObjectType">
  <xs:sequence>
    <xs:element name="QueryString" form="unqualified"
      type="DTS:DMQueryTaskQueryStringContainerType"/>
    <xs:element name="QueryBuilderQueryString" form="unqualified"
      type="DTS:DMQueryTaskQueryStringContainerType"/>
    <xs:element name="QueryBuilderSpecification" form="unqualified"
      type="DTS:DMQueryBuilderSpecificationType"/>
  </xs:sequence>
  <xs:attribute name="InputConnection" type="xs:string"
    form="unqualified"/>
  <xs:attribute name="OutputConnection" type="xs:string"
    form="unqualified"/>
  <xs:attribute name="ModelStructureName" type="xs:string"
    form="unqualified"/>
  <xs:attribute name="ModelName" type="xs:string" form="unqualified"/>
  <xs:attribute name="OverwriteOutputTable" form="unqualified">
    <xs:simpleType>
      <xs:restriction base="xs:string">

```

```

        <xs:enumeration value="True"/>
        <xs:enumeration value="False"/>
    </xs:restriction>
</xs:simpleType>
</xs:attribute>
<xs:attribute name="OutputTableName" type="xs:string"
    form="unqualified"/>
</xs:complexType>

```

The following table specifies the elements of the **DMQueryTaskDataObjectDataType** complex type.

Element	Type definition	Description
QueryString	DMQueryTaskQueryStringContainerType	A string that specifies a data mining query. <70>
QueryBuilderQueryString	DMQueryTaskQueryStringContainerType	A string that specifies a data mining query that appears in the UI for data mining as the initial query string, which the user can then modify.
QueryBuilderSpecification	DMQueryBuilderSpecificationType	The complex content contained in the QueryBuilderSpecification element specifies information about the state of the Microsoft® SQL Server® Integration Services (SSIS) UI between sessions so that editing sessions can start from where a previous session finished. Further description of the contents of this element is not within the scope of this document.

The following table specifies the attributes of the **DMQueryTaskDataObjectDataType** complex type.

Attribute	Description
InputConnection	This string value is the connection string to the data source for the data mining operation.
OutputConnection	This string value is the connection string to the database where the results of the data mining operation are written.
ModelStructureName	This string value contains the name of the data mining structure [MSDN-MSASDM] that is used for the data mining operation.
ModelName	This string value contains the name of the data mining model [MSDN-MMASDM] that is used for the data mining operation.
OverwriteOutputTable	This enumeration value specifies whether the table that is specified in the OutputTableName attribute can be overwritten.

Attribute	Description
	"True" specifies that data in the output table can be overwritten. "False" specifies that data in the output table MUST NOT be overwritten.
OutputTableName	The name of the table in the output database where the results of the data mining operation are written.

2.7.1.6.1 DMQueryTaskQueryStringContainerType

The **DMQueryTaskQueryStringContainerType** complex type contains a string value that is the value of the specific element that is of the **DMQueryTaskQueryStringContainerType** complex type.

The following is the XSD for the **DMQueryTaskQueryStringContainerType** complex type.

```
<xs:complexType name="DMQueryTaskQueryStringContainerType">
  <xs:simpleContent>
    <xs:extension base="xs:string">
      <xs:attribute name="Sensitive" type="xs:boolean"
        form="unqualified"/>
      <xs:attribute name="Encrypted" type="xs:boolean"
        form="unqualified"/>
    </xs:extension>
  </xs:simpleContent>
</xs:complexType>
```

The **DMQueryTaskQueryStringContainerType** complex type MUST NOT contain any elements. The value of the **DMQueryTaskQueryStringContainerType** complex type is a string value, because the type is an extension of the string type. Attributes are added to the string type, as specified in this section.

The following table specifies additional information for the attributes of the **DMQueryTaskQueryStringContainerType** complex type.

Attribute	Description
Sensitive	The attribute value contains an indicator for whether the string that is the value of the element is treated as sensitive. FALSE specifies that the element string value is not considered to be sensitive. TRUE specifies that the element string value is considered to be sensitive.
Encrypted	The attribute value contains an indicator for whether the element value is encrypted. FALSE specifies that the element value is not encrypted. TRUE specifies that the element value is encrypted. For more details about the encryption algorithm that is used if the value of the Encrypted attribute is TRUE, see Security .

2.7.1.6.2 DMQueryBuilderSpecificationType

The **DMQueryBuilderSpecificationType** complex type contains unspecified XML content that is used for the Microsoft® SQL Server® Integration Services (SSIS) UI.

The following is the XSD for the **DMQueryBuilderSpecificationType** complex type.

```
<xs:complexType name="DMQueryBuilderSpecificationType">
  <xs:sequence>
    <xs:any minOccurs="0" maxOccurs="unbounded"
      namespace="##any" processContents="lax"/>
  </xs:sequence>
  <xs:attribute name="Sensitive" type="xs:boolean"
    form="unqualified"/>
  <xs:attribute name="Encrypted" type="xs:boolean"
    form="unqualified"/>
</xs:complexType>
```

The following table specifies additional information for the attributes of the **DMQueryBuilderSpecificationType** complex type.

Attribute	Description
Sensitive	The attribute value contains an indicator for whether the element content is treated as sensitive. FALSE specifies that the element content is not considered to be sensitive. TRUE specifies that the element content is considered to be sensitive.
Encrypted	The attribute value contains an indicator for whether the element content is encrypted. FALSE specifies that the element content is not encrypted. TRUE specifies that the element content is encrypted.

2.7.1.7 DataProfilingTaskDataObjectDataType

The **DataProfilingTaskDataObjectDataType** complex type is used to specify parameters, properties, and settings that are specific to the Data Profiling Task.

The following is the XSD for the **DataProfilingTaskDataObjectDataType** complex type.

```
<xs:complexType name="DataProfilingTaskDataObjectDataType">
  <xs:sequence>
    <xs:element name="ProfileInput" type="xs:string"
      form="unqualified"/>
  </xs:sequence>
  <xs:attribute name="DestinationType" form="unqualified"
    type="DTS:DestinationTypeEnum"
    use="optional" default="FileConnection"/>
  <xs:attribute name="Destination" type="xs:string"
    form="unqualified" use="optional" default=""/>
  <xs:attribute name="OverwriteDestination" form="unqualified"
    use="optional" default="False">
    <xs:simpleType>
      <xs:restriction base="xs:string">
        <xs:enumeration value="True"/>
        <xs:enumeration value="False"/>
      </xs:restriction>
    </xs:simpleType>
  </xs:attribute>
```

```
</xs:complexType>
```

The following table specifies the elements of the **DataProfilingTaskDataObjectType** complex type.

Element	Type definition	Description
ProfileInput	String. Content of the string is further defined in Data Profiling ProfileInput String Format Definition .	A string value that contains encoded XML that specifies parameters, properties, and settings for the Data Profiling Task.

The following table specifies the attributes of the **DataProfilingTaskDataObjectType** complex type.

Attribute	Description
DestinationType	This enumeration value specifies whether to save the output to a file connection or to a variable.
Destination	This string specifies the name of the file connection or the name of the variable in which to save the Data Profiling Task output.
OverwriteDestination	This enumeration value specifies whether the output from this task can overwrite any previously existing content at the output destination. "True" specifies that previously existing content at the destination for output can be overwritten. "False" specifies that previously existing content at the destination for output MUST NOT be overwritten.

2.7.1.7.1 Data Profiling ProfileInput String Format Definition

The **ProfileInput** element appears within the Microsoft® SQL Server® Integration Services (SSIS) package stream as a string value. This string value is shown in the XSD in [DataProfilingTaskDataObjectType](#) where the **ProfileInput** element is defined as type **xs:string**.

However, the content of that string value is encoded XML. This section specifies the XML in the string value by using XSD. Despite the use of XSD in these sections, this value is a string at the Integration Services package level.

2.7.1.7.1.1 DataProfile Root Element of the ProfileInput String

The root element of the XML that is encoded as a string that is contained in the **ProfileInput** element is the **DataProfile** element.

The following is the XSD of the **DataProfile** element declaration.

```
<xs:element name="DataProfile">
  <xs:complexType>
    <xs:sequence>
      <xs:element name="DataSources" type="DataSourcesType" />
      <!-- Input -->
      <xs:element name="DataProfileInput" type="DataProfileInputType" />
    </xs:sequence>
  </xs:complexType>
</xs:element>
```

```

        minOccurs="0" maxOccurs="1" />
    <!-- Output -->
    <xs:element name="DataProfileOutput" type="DataProfileOutputType"
        minOccurs="0" maxOccurs="1" />
    </xs:sequence>
</xs:complexType>
</xs:element>

```

The following table specifies additional information about the elements and types for the **DataProfile** root element.

Element	Type definition	Description
DataSources	DataSourcesType	This complex type specifies the data sources that are referenced by the Data Profiling Task.
DataProfileInput	DataProfileInputType	This complex type specifies what should be profiled and how it should be profiled.
DataProfileOutput	DataProfileOutputType	This complex type specifies the profile output.

2.7.1.7.1.1.1 DataSourcesType

The **DataSourcesType** complex type MAY contain references to data sources. [<71>](#)

The following is the XSD of the **DataSourcesType** complex type.

```

<xs:complexType name="DataSourcesType">
  <xs:sequence>
</xs:sequence>
</xs:complexType>

```

2.7.1.7.1.1.2 DataProfileInputType

The **DataProfileInputType** complex type is used to specify parameters, properties, and settings that are specific to the Data Profiling Task.

The following is the XSD of the **DataProfileInputType** complex type.

```

<xs:complexType name="DataProfileInputType">
  <xs:sequence>
    <xs:element name="ProfileMode" type="ProfileModeType"
        minOccurs="1" maxOccurs="1" />
    <xs:element name="Timeout" type="xs:int" minOccurs="0"
        maxOccurs="1" default="0" />
    <xs:element name="Requests" minOccurs="1" maxOccurs="1">
      <xs:complexType>
        <xs:sequence>
          <xs:element ref="ProfileRequest" minOccurs="0"
              maxOccurs="unbounded" />
        </xs:sequence>
      </xs:complexType>
    </xs:element>
  </xs:sequence>
</xs:complexType>

```

```

</xs:sequence>
</xs:complexType>

```

The following table specifies additional information about the elements and types for the **DataProfileInputType** complex type.

Element	Type definition	Description
ProfileMode	ProfileModeType	An enumeration value that specifies in which mode the profile is run. <72>
Timeout	xs:integer	An integer value that specifies the timeout interval for the Data Profiling Task in seconds.
Requests	ProfileRequest	A complex type that contains all of the profile requests to be run by the Data Profiling Task.

2.7.1.7.1.1.2.1 ProfileModeType

The **ProfileModeType** type specifies the enumeration values for the **ProfileMode** element.

The following is the XSD of the **ProfileModeType** type.

```

<xs:simpleType name="ProfileModeType">
  <xs:restriction base="xs:string">
    <xs:enumeration value="Fast" />
    <xs:enumeration value="Exact" />
  </xs:restriction>
</xs:simpleType>

```

The following table specifies the enumeration values for the **ProfileModeType** type.

Enumeration value	Description
Fast	The profile is computed in fast mode, but may not be exact.
Exact	An exact profile is computed.

2.7.1.7.1.1.2.2 ProfileRequest Element

The **ProfileRequest** element is an abstract element that is a placeholder for elements that contain a specific data profile request. Elements that can be substituted for this placeholder have the **substitutionGroup** attribute of the element set to the value "ProfileRequest".

The following is the XSD of the **ProfileRequest** element.

```

<xs:element name="ProfileRequest" type="ProfileRequestType"
  abstract="true" />

```

2.7.1.7.1.1.2.2.1 ProfileRequestType

The **ProfileRequestType** abstract type is used to hold a profile request. The **ProfileRequestType** abstract type specifies an attribute that is common to many requests. The content of elements of type **ProfileRequestType** is specified for each specific element that can be substituted for the element of this type that appears in an XML instance document.

The following is the XSD of the **ProfileRequestType** abstract type.

```
<xs:complexType name="ProfileRequestType" abstract="true">
  <xs:attribute
    name="ID" type="xs:string" use="required" />
</xs:complexType>
```

The **ProfileRequestType** abstract type can contain elements, depending on the type of the element that is substituted.

The following table specifies additional information for the attributes of the **ProfileRequestType** abstract type.

Attribute	Description
ID	A string value that specifies an identification string that is used to refer to the data profile request elsewhere in the package.

2.7.1.7.1.1.2.2.1.1 Elements That Can Be Substituted for the ProfileRequest Element

The following elements have the XSD **substitutionGroup** attribute set to "ProfileRequest" in their XSD definition. Thus, they can be substituted for the [ProfileRequest](#) element.

- [ColumnStatisticsProfileRequest](#)
- [ColumnLengthDistributionProfileRequest](#)
- [ColumnValueDistributionProfileRequest](#)
- [ColumnNullRatioProfileRequest](#)
- [ColumnPatternProfileRequest](#)
- [CandidateKeyProfileRequest](#)
- [FunctionalDependencyProfileRequest](#)
- [InclusionProfileRequest](#)

2.7.1.7.1.1.2.2.1.2 ColumnStatisticsProfileRequest Element

The **ColumnStatisticsProfileRequest** element is used to specify parameters, properties, and settings that are used to request a **column statistics profile**. The **ColumnStatisticsProfileRequest** element has the XSD **substitutionGroup** attribute set to the value "ProfileRequest"; therefore, it is one of the elements that can be substituted for the [ProfileRequest](#) element.

The following is the XSD of the **ColumnStatisticsProfileRequest** element declaration.

```
<xs:element name="ColumnStatisticsProfileRequest"
            type="ColumnStatisticsProfileRequestType"
            substitutionGroup="ProfileRequest" />
```

2.7.1.7.1.1.2.2.1.2.1 ColumnStatisticsProfileRequestType

The **ColumnStatisticsProfileRequestType** complex type is the type of the [ColumnStatisticsProfileRequest](#) element.

The following is the XSD of the **ColumnStatisticsProfileRequestType** complex type.

```
<xs:complexType name="ColumnStatisticsProfileRequestType"
               final="#all">
  <xs:complexContent>
    <xs:extension base="ColumnProfileRequestType">
    </xs:extension>
  </xs:complexContent>
</xs:complexType>
```

All of the elements and attributes of the **ColumnStatisticsProfileRequestType** type are contained in the definition of its base type, the [ColumnProfileRequestType](#) complex type. The **ColumnStatisticsProfileRequestType** type MUST NOT contain additions or extensions that are not specified in the **ColumnProfileRequestType** complex type.

2.7.1.7.1.1.2.2.1.3 ColumnLengthDistributionProfileRequest Element

The **ColumnLengthDistributionProfileRequest** element is used to specify parameters, properties, and settings that are used to request **column length distribution profiles**. The **ColumnLengthDistributionProfileRequest** element has the XSD **substitutionGroup** attribute set to the value "ProfileRequest"; therefore, it is one of the elements that can be substituted for the [ProfileRequest](#) element.

The following is the XSD of the **ColumnLengthDistributionProfileRequest** element declaration.

```
<xs:element name="ColumnLengthDistributionProfileRequest"
            type="ColumnLengthDistributionProfileRequestType"
            substitutionGroup="ProfileRequest" />
```

2.7.1.7.1.1.2.2.1.3.1 ColumnLengthDistributionProfileRequestType

The **ColumnLengthDistributionProfileRequestType** complex type is the type of the [ColumnLengthDistributionProfileRequest](#) element.

The following is the XSD of the **ColumnLengthDistributionProfileRequestType** complex type.

```
<xs:complexType name="ColumnLengthDistributionProfileRequestType"
               final="#all">
  <xs:complexContent>
```

```

<xs:extension base="ColumnProfileRequestType">
  <xs:sequence>
    <xs:element name="IgnoreLeadingSpace" type="xs:boolean"
      minOccurs="0" maxOccurs="1" default="false" />
    <xs:element name="IgnoreTrailingSpace" type="xs:boolean"
      minOccurs="0" maxOccurs="1" default="true" />
  </xs:sequence>
</xs:extension>
</xs:complexContent>
</xs:complexType>

```

The **ColumnLengthDistributionProfileRequestType** complex type is an extension of the [ColumnProfileRequestType](#) complex type. The following table specifies additional information about the elements in the **ColumnLengthDistributionProfileRequestType** complex type.

Element	Type definition	Description
IgnoreLeadingSpace	xs:Boolean	A Boolean value that specifies whether to ignore leading spaces when comparing string values. TRUE indicates that leading spaces MUST be ignored when comparing string values. FALSE indicates that leading spaces MUST NOT be ignored when comparing string values.
IgnoreTrailingSpace	xs:Boolean	A Boolean value that specifies whether to ignore trailing spaces when comparing string values. TRUE indicates that trailing spaces MUST be ignored when comparing string values. FALSE indicates that trailing spaces MUST NOT be ignored when comparing string values.

2.7.1.7.1.1.2.2.1.4 ColumnValueDistributionProfileRequest Element

The **ColumnValueDistributionProfileRequest** element is used to specify parameters, properties, and settings that are used to request **column value distribution profiles**. The **ColumnValueDistributionProfileRequest** element has the XSD **substitutionGroup** attribute set to the value "ProfileRequest"; therefore, it is one of the elements that can be substituted for the [ProfileRequest](#) element.

The following is the XSD of the **ColumnValueDistributionProfileRequest** element declaration.

```

<xs:element name="ColumnValueDistributionProfileRequest"
  type="ColumnValueDistributionProfileRequestType"
  substitutionGroup="ProfileRequest" />

```

2.7.1.7.1.1.2.2.1.4.1 ColumnValueDistributionProfileRequestType

The **ColumnValueDistributionProfileRequestType** complex type is the type of the [ColumnValueDistributionProfileRequest](#) element.

The following is the XSD of the **ColumnValueDistributionProfileRequestType** complex type.

```

<xs:complexType name="ColumnValueDistributionProfileRequestType"
  final="#all">
  <xs:complexContent>
    <xs:extension base="ColumnProfileRequestType">
      <xs:sequence>
        <xs:element name="Option" type="ValueDistributionOptions"
          minOccurs = "1" />
        <xs:element name="FrequentValueThreshold" type="xs:double"
          minOccurs="0" maxOccurs="1" />
      </xs:sequence>
    </xs:extension>
  </xs:complexContent>
</xs:complexType>

```

The **ColumnValueDistributionProfileRequestType** complex type is an extension of the [ColumnProfileRequestType](#) complex type. The following table specifies additional information about the elements in the **ColumnValueDistributionProfileRequestType** complex type.

Element	Type definition	Description
Option	ValueDistributionOptions	This enumeration value specifies whether to include all values in the distribution computation.
FrequentValueThreshold	xs:double	This double value specifies the threshold at which to include values in the distribution computation. This value MUST be a value between 0 and 1, inclusive. This value is ignored if the value of the Option attribute is not equal to "FrequentValueThreshold". <73>

2.7.1.7.1.1.2.2.1.4.1.1 ValueDistributionOptions

The **ValueDistributionOptions** type specifies the enumeration values for the **Options** element.

The following is the XSD of the **ValueDistributionOptions** type.

```

<xs:simpleType name="ValueDistributionOptions">
  <xs:restriction base="xs:string">
    <xs:enumeration value="AllValues" />
    <xs:enumeration value="FrequentValues" />
  </xs:restriction>
</xs:simpleType>

```

The following table specifies the enumeration values for the **ValueDistributionOptions** type.

Enumeration value	Description
AllValues	The distribution is computed for all values.
FrequentValues	The distribution is computed only for values whose frequency exceeds the minimum value that is specified in the FrequentValueThreshold element.

2.7.1.7.1.1.2.2.1.5 ColumnNullRatioProfileRequest Element

The **ColumnNullRatioProfileRequest** element is used to specify parameters, properties, and settings that are used to request **column null ratio distribution profiles**. The **ColumnNullRatioProfileRequest** element has the XSD **substitutionGroup** attribute set to the value "ProfileRequest"; therefore, it is one of the elements that can be substituted for the [ProfileRequest](#) element.

The following is the XSD of the **ColumnNullRatioProfileRequest** element declaration.

```
<xs:element name="ColumnNullRatioProfileRequest"
  type="ColumnNullRatioProfileRequestType"
  substitutionGroup="ProfileRequest" />
```

2.7.1.7.1.1.2.2.1.5.1 ColumnNullRatioProfileRequestType

The **ColumnNullRatioProfileRequestType** complex type is the type of the [ColumnNullRatioProfileRequest](#) element.

The following is the XSD of the **ColumnNullRatioProfileRequestType** complex type.

```
<xs:complexType name="ColumnNullRatioProfileRequestType"
  final="#all">
  <xs:complexContent>
    <xs:extension base="ColumnProfileRequestType">
    </xs:extension>
  </xs:complexContent>
</xs:complexType>
```

All of the elements and attributes of the **ColumnNullRatioProfileRequestType** complex type are contained in the definition of its base type, the [ColumnProfileRequestType](#) complex type. The **ColumnNullRatioProfileRequestType** type MUST NOT contain additions or extensions that are not specified in the **ColumnProfileRequestType** complex type.

2.7.1.7.1.1.2.2.1.6 CandidateKeyProfileRequest Element

The **CandidateKeyProfileRequest** element is used to specify parameters, properties, and settings that are used to request **candidate key profiles**. The **CandidateKeyProfileRequest** element has the XSD **substitutionGroup** attribute set to the value "ProfileRequest"; therefore, the **CandidateKeyProfileRequest** element is one of the elements that can be substituted for the [ProfileRequest](#) element.

The following is the XSD of the **CandidateKeyProfileRequest** element declaration.

```
<xs:element name="CandidateKeyProfileRequest"
  type="CandidateKeyProfileRequestType"
  substitutionGroup="ProfileRequest" />
```

2.7.1.7.1.1.2.2.1.6.1 CandidateKeyProfileRequestType

The **CandidateKeyProfileRequestType** complex type is the type of the [CandidateKeyProfileRequest](#) element.

The following is the XSD of the **CandidateKeyProfileRequestType** complex type.

```
<xs:complexType name="CandidateKeyProfileRequestType"
  final="#all">
  <xs:complexContent>
    <xs:extension base="TableProfileRequestType">
      <xs:sequence>
        <xs:element name="KeyColumns"
          type="ColumnParameterCollectionType"
          minOccurs="1" maxOccurs="1" />
        <xs:element name="ThresholdSetting"
          type="StrengthThresholdSettingType"
          minOccurs="1" maxOccurs="1" />
        <xs:element name="KeyStrengthThreshold" type="xs:double"
          minOccurs="0" maxOccurs="1" />
        <xs:element name="VerifyOutputInFastMode" type="xs:boolean"
          default="true" minOccurs="0" maxOccurs="1" />
        <xs:element name="MaxNumberOfViolations" type="xs:int"
          minOccurs="0" maxOccurs="1" default="-1" />
      </xs:sequence>
    </xs:extension>
  </xs:complexContent>
</xs:complexType>
```

The **CandidateKeyProfileRequestType** complex type is an extension of the [TableProfileRequestType](#) complex type. The following table specifies additional information about the elements in the **CandidateKeyProfileRequestType** complex type.

Element	Type definition	Description
KeyColumns	ColumnParameterCollectionType	A complex type that specifies the column or columns to be profiled as key candidates.
ThresholdSetting	StrengthThresholdSettingType	An enumeration value that specifies what type of threshold to use in identifying a key candidate.
KeyStrengthThreshold	xs:double	A double value that specifies the minimum strength that is required to report a candidate key. This value is used only if the ThresholdSetting element is set to the value "Specified". <74>
VerifyOutputInFastMode	xs:Boolean	A Boolean value that specifies whether the output verification step is performed in fast mode. TRUE specifies that output verification is performed in fast mode. FALSE specifies that output verification

Element	Type definition	Description
		is not performed in fast mode. <75>
MaxNumberOfViolations	xs:int	An integer value that specifies the maximum number of candidate key violations to report in the output. This option is disabled when the KeyStrengthThreshold element is set to the value "Exact". <76>

2.7.1.7.1.1.2.2.1.7 FunctionalDependencyProfileRequest Element

The **FunctionalDependencyProfileRequest** element is used to specify parameters, properties, and settings that are used to request **functional dependency profiles**. The **FunctionalDependencyProfileRequest** element has the XSD **substitutionGroup** attribute set to the value "ProfileRequest"; therefore, it is one of the elements that can be substituted for the [ProfileRequest](#) element.

The following is the XSD of the **FunctionalDependencyProfileRequest** element declaration.

```
<xs:element name="FunctionalDependencyProfileRequest"
  type="FunctionalDependencyProfileRequestType"
  substitutionGroup="ProfileRequest" />
```

2.7.1.7.1.1.2.2.1.7.1 FunctionalDependencyProfileRequestType

The **FunctionalDependencyProfileRequestType** complex type is the type of the [FunctionalDependencyProfileRequest](#) element.

The following is the XSD of the **FunctionalDependencyProfileRequestType** complex type.

```
<xs:complexType name="FunctionalDependencyProfileRequestType"
  final="#all">
  <xs:complexContent>
    <xs:extension base="TableProfileRequestType">
      <xs:sequence>
        <xs:element name="DeterminantColumns"
          type="ColumnParameterCollectionType"
          minOccurs="1" maxOccurs="1" />
        <xs:element name="DependentColumn" type="ColumnParameterType"
          minOccurs="1" maxOccurs="1" />
        <xs:element name="ThresholdSetting"
          type="StrengthThresholdSettingType"
          minOccurs="1" maxOccurs="1" />
        <xs:element name="FDStrengthThreshold" type="xs:double"
          minOccurs="0" maxOccurs="1" />
        <xs:element name="VerifyOutputInFastMode" type="xs:boolean"
          default="true" minOccurs="0" maxOccurs="1" />
        <xs:element name="MaxNumberOfViolations" default="-1"
          type="xs:int" minOccurs="0" maxOccurs="1" />
      </xs:sequence>
    </xs:extension>
  </xs:complexContent>
```

</xs:complexType>

The **FunctionalDependencyProfileRequestType** complex type is an extension of the [TableProfileRequestType](#) complex type. The following table specifies additional information about the elements in the **FunctionalDependencyProfileRequestType** complex type.

Element	Type definition	Description
DeterminantColumns	ColumnParameterCollectionType	A complex type that specifies a collection of determinant columns, which are the columns that are assessed for their ability to determine the dependent columns.
DependentColumn	ColumnParameterType	A complex type that specifies the column for which the dependency on the determinant columns is computed.
ThresholdSetting	StrengthThresholdSettingType	An enumeration value that specifies what type of threshold to use to identify a key candidate.
FDStrengthThreshold	xs:double	A double value that specifies the minimum functional dependency threshold that is required to consider a dependency as existing. This value is used only if the value of the ThresholdSetting element is set to "Specified". <77>
VerifyOutputInFastMode	xs:boolean	A Boolean value that specifies whether the output verification step is performed in fast mode. TRUE specifies that output verification is performed in fast mode. FALSE specifies that output verification is not performed in fast mode. <78>
MaxNumberOfViolations	xs:int	An integer value that specifies the maximum number of candidate key violations to report in the output. This option is disabled when the KeyStrengthThreshold element is set to the value "Exact". <79>

2.7.1.7.1.1.2.2.1.8 InclusionProfileRequest Element

The **InclusionProfileRequest** element is used to specify parameters, properties, and settings that are used to request **value inclusion profiles**. The **InclusionProfileRequest** element has the XSD **substitutionGroup** attribute set to the value "ProfileRequest"; therefore, the **InclusionProfileRequest** element is one of the elements that can be substituted for the [ProfileRequest](#) element.

The following is the XSD of the **InclusionProfileRequest** element declaration.

```

<xs:element name="InclusionProfileRequest"
  type="InclusionProfileRequestType"
  substitutionGroup="ProfileRequest" />

```

2.7.1.7.1.1.2.2.1.8.1 InclusionProfileRequestType

The **InclusionProfileRequestType** complex type is the type of the [InclusionProfileRequest](#) element.

The following is the XSD of the **InclusionProfileRequestType** complex type.

```

<xs:complexType name="InclusionProfileRequestType" final="#all">
  <xs:complexContent>
    <xs:extension base="ProfileRequestType">
      <xs:sequence>
        <xs:element name="SubsetDataSourceID" type="xs:string"
          minOccurs="0" maxOccurs="1" />
        <xs:element name="SubsetTable" type="TableQNameType"
          minOccurs="1" maxOccurs="1" />
        <xs:element name="SubsetColumns"
          type="ColumnParameterCollectionType"
          minOccurs="1" maxOccurs="1" />
        <xs:element name="SupersetDataSourceID" type="xs:string"
          minOccurs="0" maxOccurs="1" />
        <xs:element name="SupersetTable" type="TableQNameType"
          minOccurs="1" maxOccurs="1" />
        <xs:element name="SupersetColumns"
          type="ColumnParameterCollectionType"
          minOccurs="1" maxOccurs="1" />
        <xs:element name="InclusionThresholdSetting"
          type="StrengthThresholdSettingType"
          minOccurs="1" maxOccurs="1" />
        <xs:element name="InclusionStrengthThreshold" type="xs:double"
          minOccurs="0" maxOccurs="1" />
        <xs:element name="SupersetColumnsKeyThresholdSetting"
          type="StrengthThresholdSettingType"
          minOccurs="1" maxOccurs="1" />
        <xs:element name="SupersetColumnsKeyThreshold" type="xs:double"
          minOccurs="0" maxOccurs="1" />
        <xs:element name="VerifyOutputInFastMode" type="xs:boolean"
          default="true" minOccurs="0" maxOccurs="1" />
        <xs:element name="MaxNumberOfViolations" default="-1"
          type="xs:int" minOccurs="0" maxOccurs="1" />
      </xs:sequence>
    </xs:extension>
  </xs:complexContent>
</xs:complexType>

```

The **InclusionProfileRequestType** complex type is an extension of the base type, the [ProfileRequestType](#) abstract type. The following table specifies additional information about the elements in the **InclusionProfileRequestType** type.

Element	Type definition	Description
SubsetDataSourceID	xs:string	A string value that contains an identifier for the subset data source.
SubsetTable	TableQNameType	A complex type that specifies information to reference the table that is used as the subset table.
SubsetColumns	ColumnParameterCollectionType	A complex type that specifies the columns that constitute the subset for which determination of the value inclusion profile is computed.
SupersetDataSourceID	xs:string	A string value that contains an identifier for the superset data source. <80>
SupersetTable	TableQNameType	A complex type that specifies information to reference the table that is used as the superset table.
SupersetColumns	ColumnParameterCollectionType	A complex type that specifies the columns that constitute the superset for which determination of the value inclusion profile is computed.
InclusionThresholdSetting	StrengthThresholdSettingType	An enumeration value that specifies what type of threshold to use in the value inclusion profile.
InclusionStrengthThreshold	xs:double	A double value that specifies the minimum inclusion strength that is required to report the inclusion strength. This value is used only if the value of the InclusionThresholdSetting element is set to "Specified". <81>
SupersetColumnsKeyThresholdSetting	StrengthThresholdSettingType	An enumeration value that specifies what type of threshold to use in the value inclusion profile for a key.
SupersetColumnsKeyThreshold	xs:double	A double value that specifies the minimum inclusion strength that is required to report the inclusion strength of the suitability of the column as a key. This value is used only if the value of the SupersetColumnsKeyThresholdSetting element is set to "Specified". <82>
VerifyOutputInFastMode	xs:boolean	A Boolean value that specifies whether the output verification step is performed in fast mode. TRUE specifies that output verification is performed in fast mode.

Element	Type definition	Description
		FALSE specifies that output verification is not performed in fast mode. <83>
MaxNumberOfViolations	xs:int	An integer value that specifies the maximum number of violations to report in the output. This option is disabled when the value of the InclusionThresholdSetting element is set to "Exact". <84>

2.7.1.7.1.1.2.2.1.9 ColumnPatternProfileRequest Element

The **ColumnPatternProfileRequest** element is used to specify parameters, properties, and settings that are used to request value inclusion profiles. The **ColumnPatternProfileRequest** element has the XSD **substitutionGroup** attribute set to the value "ProfileRequest"; therefore, it is one of the elements that can be substituted for the [ProfileRequest](#) element.

The following is the XSD of the **InclusionProfileRequest** element declaration.

```
<xs:element name="ColumnPatternProfileRequest"
  type="ColumnPatternProfileRequestType"
  substitutionGroup="ProfileRequest" />
```

2.7.1.7.1.1.2.2.1.9.1 ColumnPatternProfileRequestType

The **ColumnPatternProfileRequestType** complex type is the type of the [ColumnPatternProfileRequest](#) element.

The following is the XSD of the **ColumnPatternProfileRequestType** complex type.

```
<xs:complexType name=" ColumnPatternProfileRequestType " final="#all">
  <xs:complexContent>
    <xs:extension base="ColumnProfileRequestType">
      <xs:sequence>
        <xs:element name="MaxNumberOfPatterns" type="xs:int"
          minOccurs="0"/>
        <xs:element name="PercentageDataCoverageDesired"
          type="xs:int" minOccurs="0"/>
        <xs:element name="CaseSensitive" type="xs:boolean"
          minOccurs="0"/>
        <xs:element name="Delimiters" type="xs:string"
          minOccurs="0"/>
        <xs:element name="Symbols" type="xs:string"
          minOccurs="0"/>
        <xs:element name="TagDataSourceId" type="xs:string"
          minOccurs="0"/>
        <xs:element name="TagTableName" type="TableNameType"
          minOccurs="0"/>
      </xs:sequence>
    </xs:extension>
  </xs:complexContent>
```

</xs:complexType>

The **ColumnPatternProfileRequestType** complex type is an extension of the base type, the [ColumnProfileRequestType](#) complex type. The following table specifies additional information about the elements in the **ColumnPatternProfileRequestType** complex type.

Element	Type definition	Description
MaxNumberOfPatterns	xs:int	An integer value that specifies the maximum number of patterns that are returned by the column pattern profile task. <85>
PercentageDataCoverageDesired	xs:int	An integer value that specifies the percentage of the data that is described by the patterns that are returned by the column pattern profile task. <86>
CaseSensitive	xs:Boolean	A Boolean value that specifies whether to consider strings as case sensitive. TRUE specifies that case MUST be considered in determining the pattern. FALSE specifies that case MUST be ignored in determining the pattern. <87>
Delimiters	xs:string	A string value that specifies the characters that are treated as the equivalent of spaces between words when tokenizing text. <88>
Symbols	xs:string	A string value that specifies the symbols that are retained as part of patterns. <89>
TagSourceID	xs:string	A string value that contains an identifier for the tag table .
TagTableName	TableQNameType	A complex type that specifies information to reference the table that is used as the tag table.

2.7.1.7.1.1.2.2.1.10 Abstract Base Types Used by Data Profiling Task

The following abstract types are used as a base for extension or restriction for instance types that are used by the Data Profiling Task.

2.7.1.7.1.1.2.2.1.10.1 ColumnProfileRequestType

The **ColumnProfileRequestType** complex type is the base type from which many types that request a profile of a column are extended.

The following is the XSD of the **ColumnProfileRequestType** complex type.

```
<xs:complexType name="ColumnProfileRequestType" abstract="true">
  <xs:complexContent>
    <xs:extension base="TableProfileRequestType">
      <xs:sequence>
        <xs:element name="Column" type="ColumnParameterType" />
      </xs:sequence>
    </xs:extension>
  </xs:complexContent>
</xs:complexType>
```

```

        minOccurs="1" maxOccurs="1" />
    </xs:sequence>
</xs:extension>
</xs:complexContent>
</xs:complexType>

```

The following table specifies additional information about the elements in the **ColumnProfileRequestType** complex type.

Element	Type definition	Description
Column	ColumnParameterType	A complex type that specifies information that is sufficient to identify a column at a data source for which a profile is being requested.

2.7.1.7.1.1.2.2.1.10.2 TableProfileRequestType

The **TableProfileRequestType** complex type is the base type from which many types that request a profile of a table or of table elements are extended.

The following is the XSD of the **TableProfileRequestType** complex type.

```

<xs:complexType name="TableProfileRequestType" abstract="true">
  <xs:complexContent>
    <xs:extension base="ProfileRequestType">
      <xs:sequence>
        <xs:element name="DataSourceID" type="xs:string"
          minOccurs = "0"/>
        <xs:element name="Table" type="TableQNameType" />
      </xs:sequence>
    </xs:extension>
  </xs:complexContent>
</xs:complexType>

```

The following table specifies additional information about the elements in the **TableProfileRequestType** complex type.

Element	Type definition	Description
DataSourceID	xs:string	A string value that contains an identifier for the data source for this table request.
Table	TableQNameType	A complex type that identifies a single table within a data source.

2.7.1.7.1.1.2.2.1.11 Other Types Used by Data Profiling Task

The following types are referenced as element types by other complex types within the Data Profiling Task.

2.7.1.7.1.1.2.2.1.11.1 TableQNameType

The **TableQNameType** complex type is used to specify an existing table in a database.

The following is the XSD of the **TableQNameType** complex type.

```

<xs:complexType name="TableQNameType">
  <xs:attribute name="Database" type="xs:string" use="optional" />
  <xs:attribute name="Schema" type="xs:string" use="optional" />
  <xs:attribute name="Table" type="xs:string" use="optional" />
</xs:complexType>

```

The **TableQNameType** complex type MUST NOT contain elements.

The following table specifies additional information for the attributes of the **TableQNameType** complex type.

Attribute	Description
Database	A string value that specifies the name of the database in which the table resides.
Schema	A string value that specifies the name of the schema within the database.
Table	A string value that specifies the name of the table within the schema.

2.7.1.7.1.1.2.2.1.11.2 ColumnParameterCollectionType

The **ColumnParameterCollectionType** complex type specifies a collection of columns that are considered as key column candidates.

The following is the XSD of the **ColumnparameterCollectionType** complex type.

```

<xs:complexType name="ColumnParameterCollectionType">
  <xs:sequence>
    <xs:element name="Column" type="ColumnParameterType"
      minOccurs="0" maxOccurs="unbounded" />
  </xs:sequence>
</xs:complexType>

```

The following table specifies additional information about the elements in the **ColumnParameterCollectionType** complex type.

Element	Type definition	Description
Column	ColumnParameterType	A complex type that specifies a single existing column by pointing to the column at its external location.

2.7.1.7.1.1.2.2.1.11.2.1 ColumnParameterType

The **ColumnParameterType** complex type specifies a collection of columns that are considered as key column candidates.

The following is the XSD of the **ColumnParameterType** complex type.

```

<xs:complexType name="ColumnParameterType">
  <xs:attribute name="IsWildcard" type="xs:boolean"
    use="required" />

```

```

<xs:attribute name="ColumnName" type="xs:string"
              use="optional" />
<xs:attribute name="StringCompareOptions"
              type="DTS:StringCompareOptionsEnum"
              use="optional" />
</xs:complexType>

```

The following table specifies additional information about the elements in the **ColumnParameterType** complex type.

Element	Type definition	Description
IsWildcard	xs:boolean	This Boolean value specifies whether the wildcard character (*) has been specified to select all columns TRUE specifies that the wildcard character has been specified; therefore, all columns in the table are selected. FALSE specifies that the wildcard character has not been specified and that specific individual columns are selected.
ColumnName	xs:string	A string value that specifies the name of a column.
StringCompareOptions	StringCompareOptionsEnum	An enumeration value that specifies the options to be used in string comparison.

2.7.1.7.1.1.2.2.1.11.2.1.1 StringCompareOptionsEnum

The **StringCompareOptionsEnum** type contains the enumeration values for the **StringCompareOptions** element. The **StringCompareOptionsEnum** type is a bitmask, but it is a bitmask in which not all combinations are permitted. The XSD enumeration enumerates only the allowed value combinations.

The following is the XSD for the **StringCompareOptionsEnum** type.

```

<xs:simpleType name="StringCompareOptionsEnum">
  <xs:restriction base="xs:int">
    <xs:enumeration value="0"/>
    <xs:enumeration value="1024"/>
    <xs:enumeration value="1025"/>
    <xs:enumeration value="1026"/>
    <xs:enumeration value="1027"/>
    <xs:enumeration value="1032"/>
    <xs:enumeration value="1033"/>
    <xs:enumeration value="1034"/>
    <xs:enumeration value="1035"/>
    <xs:enumeration value="1040"/>
    <xs:enumeration value="1041"/>
    <xs:enumeration value="1042"/>
    <xs:enumeration value="1043"/>
    <xs:enumeration value="1048"/>
    <xs:enumeration value="1050"/>
    <xs:enumeration value="1051"/>
  </xs:restriction>
</xs:simpleType>

```

```
<xs:enumeration value="32768"/>
</xs:restriction>
```

The following table specifies the enumeration values for the **StringCompareOptionsEnum** type.

Enumeration value	Description
0	Default.
1024	Dictionary sort.
1025	Dictionary sort, ignore case.
1026	Dictionary sort, ignore non-space characters.
1027	Dictionary sort, ignore case, and ignore non-space characters.
1032	Dictionary sort, ignore kana type.
1033	Dictionary sort, ignore case, and ignore kana type.
1034	Dictionary sort, ignore non-space characters, and ignore kana type.
1035	Dictionary sort, ignore case, ignore non-space characters, and ignore kana type.
1040	Dictionary sort, ignore width.
1041	Dictionary sort, ignore case, and ignore width.
1042	Dictionary sort, ignore non-space characters, and ignore width.
1043	Dictionary sort, ignore case, ignore non-space characters, and ignore width.
1048	Dictionary sort, ignore kana type, and ignore width.
1050	Dictionary sort, ignore non-space characters, ignore kana type, and ignore width.
1051	Dictionary sort, ignore case, ignore non-space characters, ignore kana type, and ignore width.
32768	Binary sort.

2.7.1.7.1.1.2.2.1.11.3 StrengthThresholdSettingType

The **StrengthThresholdSettingType** type specifies the enumeration values for the **ThresholdSetting** element.

The following is the XSD of the **StrengthThresholdSettingType** type.

```
<xs:simpleType name="StrengthThresholdSettingType">
  <xs:restriction base="xs:string">
    <xs:enumeration value="None" />
    <xs:enumeration value="Specified" />
    <xs:enumeration value="Exact" />
  </xs:restriction>
</xs:simpleType>
```

```
</xs:simpleType>
```

The following table specifies the enumeration values for the **StrengthThresholdSettingType** type.

Enumeration value	Description
None	No threshold is specified. The key strength is reported, regardless of its value.
Specified	A threshold is specified as the value of the KeyStrengthThreshold element. The key strength is reported only if it is greater than the threshold.
Exact	No threshold is specified. The key strength is reported only if the selected columns are an exact key.

2.7.1.7.1.1.3 DataProfileOutputType

The **DataProfileOutputType** complex type contains the computed profile results. [<90>](#)

The following is the XSD of the **DataProfileOutputType** complex type.

```
<xs:complexType name="DataProfileOutputType">
  <xs:sequence>
    <xs:element name="Profiles" type="ProfilesType"
      minOccurs="1" maxOccurs="1" />
  </xs:sequence>
</xs:complexType>
```

The following table specifies additional information about the elements and types for the **DataProfileOutputType** complex type.

Element	Type definition	Description
Profiles	ProfilesType	A complex type that MAY contain an output profile. <91>

2.7.1.7.1.1.3.1 ProfilesType

The **ProfilesType** complex type contains the computed profile results.

The **ProfilesType** complex type MUST be empty.

The following is the XSD of the **ProfilesType** complex type.

```
<xs:complexType name="ProfilesType">
  <xs:sequence/>
</xs:complexType>
```

2.7.1.8 Exec80PackageTaskData Element

The **Exec80PackageTaskData** element is used to specify parameters, properties, and settings that are specific to the execution of a **Data Transformation Services (DTS) 2000 Package** as a task.

The **Exec80PackageTaskData** element resides in the [Exec80PackageTask](#) namespace. The [ExecutableObjectDataType](#) type refers to this element within an XSD **choice** element, using the XSD **ref** attribute, in the following XSD fragment.

```
<xs:element ref="Exec80PackageTask:Exec80PackageTaskData"/>
```

2.7.1.8.1 Exec80PackageTask Namespace

The **Exec80PackageTask** namespace specifies the elements and types that are used by the Execute DTS 2000 Package Task.

The following is the XSD declaration for the **Exec80PackageTask** namespace.

```
xmlns:Exec80PackageTask=  
"www.microsoft.com/sqlserver/dts/tasks/exec80packagetask"
```

2.7.1.8.1.1 Exec80PackageTaskData Element

The following is the XSD for the element declaration for the **Exec80PackageTaskData** element in the [Exec80PackageTask](#) namespace.

```
<xs:element name="Exec80PackageTaskData"  
  type="Exec80PackageTask:Exec80PackageTaskType"/>
```

2.7.1.8.1.1.1 Exec80PackageTaskType

The **Exec80PackageTaskType** complex type holds parameters, properties, and settings for an Execute DTS 2000 Package Task.

The following is the XSD for the **Exec80PackageTaskType** complex type.

```
<xs:complexType name="Exec80PackageTaskType">  
  <xs:sequence>  
    <xs:element name="DTS2000Package" type="xs:base64Binary"  
      minOccurs="0" form="unqualified"/>  
  </xs:sequence>  
  <xs:attribute name="Location"  
    type="Exec80PackageTask:Exec80PackageTaskLocationEnum"/>  
  <xs:attribute name="PackageName" type="xs:string"/>  
  <xs:attribute name="PackageID" type="xs:string"/>  
  <xs:attribute name="PackageVersionGUID" type="xs:string"/>  
  <xs:attribute name="SQLServer" type="xs:string"/>  
  <xs:attribute name="SQLUsername" type="xs:string"/>  
  <xs:attribute name="WindowsAuthentication">  
    <xs:simpleType>  
      <xs:restriction base="xs:string">  
        <xs:enumeration value="True"/>  
        <xs:enumeration value="False"/>  
      </xs:restriction>  
    </xs:simpleType>  
  </xs:attribute>  
</xs:complexType>
```

```

    </xs:simpleType>
  </xs:attribute>
  <xs:attribute name="Filename" type="xs:string"/>
  <xs:attribute name="InnerGlobalVariables" type="xs:string"/>
  <xs:attribute name="OuterGlobalVariables" type="xs:string"/>
</xs:complexType>

```

The following table specifies the elements of the **Exec80PackageTaskType** complex type.

Element	Type definition	Description
DTS2000Package	xs:base64Binary	This element stores the content of the DTS 2000 Package in binary format. If this element is present, the DTS 2000 package is not retrieved from an external location.

The following table specifies additional information for the attributes of the **Exec80PackageTaskType** complex type.

Attribute	Description
Location	This enumeration value specifies the storage location for the DTS 2000 package file.
PackageName	This string specifies the name of the DTS 2000 package that is executed.
PackageID	This GUID value specifies the ID of the DTS 2000 package that is executed.
PackageVersionGUID	A GUID value that is unique to every version of the package. <92>
SQLServer	This string value contains the name of the server instance. <93>
SQLUsername	This string value contains the database username. <94>
WindowsAuthentication	An enumeration value that specifies whether Windows Authentication is used. "True" specifies that Windows Authentication is used. "False" specifies that Windows Authentication is not used.
Filename	This string value specifies the name of the file. This value is used only if the Location attribute has a value of "StorageFile".
InnerGlobalVariables	A string value that contains a collection of variables that are the inner variables for the task.
OuterGlobalVariables	A string value that contains a collection of variables that are the outer variables for the task.

2.7.1.8.1.1.1.1 Exec80PackageTaskEnum

The **Exec80PackageTaskEnum** type contains the enumeration values for the **Location** attribute.

The following is the XSD for the **Exec80PackageTaskEnum** type.

```

<xs:simpleType name="Exec80PackageTaskLocationEnum">
  <xs:restriction base="xs:string">
    <xs:enumeration value="SqlServer"/>
  </xs:restriction>
</xs:simpleType>

```



```

    <xs:enumeration value="EmbeddedInTask"/>
    <xs:enumeration value="StorageFile"/>
  </xs:restriction>
</xs:simpleType>

```

The following table specifies the enumeration values for the **Exec80PackageTaskEnum** type.

Enumeration value	Description
SqlServer	Specifies that the DTS2000 Package file is stored on a database server. <95>
EmbeddedInTask	Specifies that the DTS2000 Package file is embedded inline in the package file.
StorageFile	Specifies that the DTS2000 Package file is stored in a file in the file system.

2.7.1.9 ExecutePackageTaskObjectDataType

The **ExecutePackageTaskObjectDataType** complex type is used to specify parameters, properties, and settings that are specific to the Execute Package Task.

The following is the XSD for the **ExecutePackageTaskObjectDataType** complex type.

```

<xs:complexType name="ExecutePackageTaskObjectDataType">
  <xs:sequence>
    <xs:element name="ExecuteOutOfProcess" form="unqualified">
      <xs:simpleType>
        <xs:restriction base="xs:string">
          <xs:enumeration value="True"/>
          <xs:enumeration value="False"/>
        </xs:restriction>
      </xs:simpleType>
    </xs:element>
    <xs:element name="PackageName" type="xs:string"
      form="unqualified"/>
    <xs:element name="UseProjectReference" type="DTS:BooleanStringCap"
      minOccurs="0" form="unqualified"/>
    <xs:element name="PackagePassword" type="DTS>PasswordElementType"
      form="unqualified"/>
    <xs:element name="PackageID" type="DTS:uuid" form="unqualified"/>
    <xs:element name="VersionID" type="DTS:uuid" form="unqualified"/>
    <xs:element name="Connection" type="xs:string" form="unqualified"/>
  </xs:sequence>
</xs:complexType>

```

The following table specifies the elements of the **ExecutePackageTaskObjectDataType** complex type.

Element	Type definition	Description
ExecuteOutOfProcess	Inline in the XSD in this section.	This enumeration value specifies whether the package is executed in a separate process. "True" specifies that the package is executed in a separate process.

Element	Type definition	Description
		"False" specifies that the package is executed within the parent process.
PackageName	String	A string value that specifies the name of the package that is run.
UseProjectReference	BooleanStringCap	A value of type BooleanStringCap that specifies whether the package to be executed is located in the same project as the current package. "True" specifies that the package to execute is located in the same project as the current package. "False" specifies that the package to execute is not located in the same project as the current package.
PackagePassword	PasswordElementType	A string value that specifies the password for use if the package is encrypted.
PackageID	UUID	A UUID value that specifies the ID of the package that is executed.
VersionID	UUID	A UUID value that specifies the version ID of the version of a package to execute.
Connection	xs:string	A string value that specifies a reference to a connection manager by its DTSID property value or by its ObjectName property value.

2.7.1.10 ExecuteProcessDataObjectDataType

The **ExecuteProcessDataObjectDataType** complex type is used to specify parameters, properties, and settings that are specific to the Execute Process Task.

The following is the XSD for the **ExecuteProcessDataObjectDataType** complex type.

```
<xs:complexType name="ExecuteProcessDataObjectDataType">
  <xs:sequence>
  </xs:sequence>
  <xs:attribute name="Executable" type="xs:string" form="unqualified"
    use="optional" default=""/>
  <xs:attribute name="RequireFullFileName" form="unqualified"
    use="optional" type="DTS:BooleanStringCap"
    default="True"/>
  <xs:attribute name="Arguments" type="xs:string" form="unqualified"
    use="optional" default=""/>
  <xs:attribute name="WorkingDirectory" type="xs:string"
    use="optional" default="" form="unqualified"/>
  <xs:attribute name="TimeOut" type="xs:string" form="unqualified"
    use="optional" default="0"/>
  <xs:attribute name="FailTaskIfReturnCodeIsNotSuccessValue"
    use="optional" default="True" form="unqualified">
    <xs:simpleType>
      <xs:restriction base="xs:string">
        <xs:enumeration value="True"/>
        <xs:enumeration value="False"/>
      </xs:restriction>
    </xs:simpleType>
  </xs:attribute>
</complexType>
```

```

    </xs:simpleType>
  </xs:attribute>
  <xs:attribute name="SuccessValue" type="xs:string" form="unqualified"
    use="optional" default="0"/>
  <xs:attribute name="TerminateAfterTimeout" form="unqualified"
    use="optional" default="True">
    <xs:simpleType>
      <xs:restriction base="xs:string">
        <xs:enumeration value="True"/>
        <xs:enumeration value="False"/>
      </xs:restriction>
    </xs:simpleType>
  </xs:attribute>
  <xs:attribute name="StandardInputVariable" type="xs:string"
    use="optional" default="" form="unqualified"/>
  <xs:attribute name="StandardOutputVariable" type="xs:string"
    use="optional" default="" form="unqualified"/>
  <xs:attribute name="StandardErrorVariable" type="xs:string"
    use="optional" default="" form="unqualified"/>
  <xs:attribute name="WindowStyle" form="unqualified"
    type="DTS:WindowStyleEnum"
    use="optional" default="Normal"/>
</xs:complexType>

```

The **ExecuteProcessDataObjectDataType** complex type MUST NOT contain elements.

The following table specifies the attributes of the **ExecuteProcessDataObjectDataType** complex type.

Attribute	Description
Executable	A string value that specifies the name of the executable to execute.
RequireFullFileName	An enumeration value that specifies whether the task fails if the executable is not found on the specified path. "True" specifies that the full file name is required and the task fails if the executable is not found on the specified path. "False" specifies that the full file name is not required and that the task can still execute if the executable is found in any location that is available to the process.
Arguments	A string value that specifies a list of arguments that is passed to the executable.
WorkingDirectory	A string value that specifies the working directory for the executable.
TimeOut	An integer value that specifies the timeout, in seconds, for the executable.
FailTaskIfReturnCodeIsNotSuccessValue	An enumeration value that specifies whether the task fails if the return code is not the same as that specified for the SuccessValue attribute. "True" specifies that the task fails if the return code is not the same as the value that is specified for the

Attribute	Description
	SuccessValue attribute. "False" specifies that the task does not fail if the return code is not the same as the value that is specified for the SuccessValue attribute.
SuccessValue	An integer value that specifies the value that is returned by the external process to indicate that the external process has completed successfully.
TerminateAfterTimeout	An enumeration value that specifies whether the task should terminate after the timeout value is reached. "True" specifies that the task terminates after the timeout value is reached. "False" specifies that the task does not terminate after the timeout value is reached.
StandardInputVariable	A string value that specifies a variable that contains input information that is passed to the process.
StandardOutputVariable	A string value that specifies a variable where output information from the process is sent.
StandardErrorVariable	A string value that specifies a variable where error information from the process is sent.
WindowStyle	An enumeration value that specifies how the new window in which the task starts a process appears.

2.7.1.10.1 WindowStyleEnum

The **WindowStyleEnum** type contains the enumeration values for specifying what the appearance is of the window that is created to run the process.

The following is the XSD for the **WindowStyleEnum** type.

```
<xs:simpleType name="WindowStyleEnum">
  <xs:restriction base="xs:string">
    <xs:enumeration value="Hidden"/>
    <xs:enumeration value="Maximized"/>
    <xs:enumeration value="Minimized"/>
    <xs:enumeration value="Normal"/>
  </xs:restriction>
</xs:simpleType>
```

The following table specifies the enumeration values for the **WindowStyleEnum** type.

Enumeration value	Description
Hidden	Specifies that the window MUST be hidden.
Maximized	Specifies that the window MUST be maximized.
Minimized	Specifies that the window MUST be minimized.

Enumeration value	Description
Normal	Specifies that the window MUST be normal size.

2.7.1.11 SqlTaskData Element

The **SqlTaskData** element is used to specify parameters, properties, and settings that are specific to the execution of an Execute SQL Task. This element resides in the [SQLTask](#) namespace. The [ExecutableObjectDataType](#) type refers to this element within an XSD **choice** element, using the XSD **ref** attribute, in the following XSD fragment.

```
<xs:element ref="SQLTask:SqlTaskData"/>
```

2.7.1.11.1 SQLTask Namespace

The **SQLTask** namespace specifies the elements and types that are used by the Execute SQL Task.

The following is the XSD declaration for the **SQLTask** namespace.

```
xmlns:SQLTask="www.microsoft.com/sqlserver/dts/tasks/sqltask"
```

2.7.1.11.1.1 SqlTaskData Element

The **SqlTaskData** element is used to specify parameters, properties, and settings that are specific to the execution of an Execute SQL Task. The following is the XSD for the element declaration for the **SqlTaskData** element in the [SQLTask](#) namespace.

```
<xs:element name="SqlTaskData" type="SQLTask:SqlTaskDataType"/>
```

2.7.1.11.1.1.1 SqlTaskDataType

The **SqlTaskDataType** complex type holds parameters, properties, and settings for the Execute SQL Task.

The following is the XSD for the **SqlTaskDataType** complex type.

```
<xs:complexType name="SqlTaskDataType">
  <xs:sequence>
    <xs:element name="SelectedDatabases"
      type="SQLTask:SelectedDatabasesType"
      minOccurs="0" maxOccurs="unbounded"/>
    <xs:element name="OperatorNotifyList"
      type="SQLTask:OperatorNotifyListType"
      minOccurs="0" maxOccurs="unbounded"/>
    <xs:element name="ParameterBinding"
      type="SQLTask:SqlTaskParameterBindingType"
      minOccurs="0" maxOccurs="unbounded"/>
    <xs:element name="ResultBinding"/>
  </xs:sequence>
</xs:complexType>
```

```

        type="SQLTask:SqlTaskResultBindingType"
        minOccurs="0" maxOccurs="1"/>
    <xs:element name="BackupDestinationList"
        type="SQLTask:BackupDestinationListType"
        minOccurs="0" maxOccurs="unbounded"/>
</xs:sequence>
<xs:attributeGroup
    ref="SQLTask:SqlTaskBaseAttributeGroup"/>
<xs:attributeGroup
    ref="SQLTask:MaintenanceTaskBaseAttributeGroup"/>
<xs:attributeGroup
    ref="SQLTask:BackupTaskAttributeGroup"/>
<xs:attributeGroup
    ref="SQLTask:CheckIntegrityTaskAttributeGroup"/>
<xs:attributeGroup
    ref="SQLTask:AgentJobTaskAttributeGroup"/>
<xs:attributeGroup
    ref="SQLTask:HistoryCleanupTaskAttributeGroup"/>
<xs:attributeGroup
    ref="SQLTask:MaintenanceFileCleanupTaskAttributeGroup"/>
<xs:attributeGroup
    ref="SQLTask:NotifyOperatorTaskAttributeGroup"/>
<xs:attributeGroup
    ref="SQLTask:RebuildIndexTaskAttributeGroup"/>
<xs:attributeGroup
    ref="SQLTask:ReorganizeIndexTaskAttributeGroup"/>
<xs:attributeGroup
    ref="SQLTask:ShrinkDBTaskAttributeGroup"/>
<xs:attributeGroup
    ref="SQLTask:UpdateStatisticsTaskAttributeGroup"/>
<xs:attributeGroup
    ref="SQLTask:TSQLExecuteTaskAttributeGroup"/>
<xs:attribute name="RemoveOlderThan" type="xs:int"/>
<xs:attribute name="TimeUnitsType"
    type="SQLTask:SqlTaskTimeUnitsTypeEnum"/>
<xs:attribute name="DatabaseSelectionType"
    type="SQLTask:SqlTaskDatabaseSelectionTypeEnum"/>
</xs:complexType>

```

The following table provides additional information about the elements, types, and constraints in the **SQLTaskDataType** complex type.

Element	Additional constraints	Type definition	Description
SelectedDatabases	The SelectedDatabases element MUST NOT be used except with the following tasks: Backup Task, Check Integrity Task, Rebuild Index Task, Reorganize Index Task, Shrink Database Task, and Update Statistics Task.	SelectedDatabasesType	A complex type value that specifies information about an existing database.
OperatorNotifyList	The OperatorNotifyList element MUST NOT be used except with the Notify	OperatorNotifyListType	A complex type value that specifies information

Element	Additional constraints	Type definition	Description
	Operator Task.		about the operators to notify.
ParameterBinding	None.	SqlTaskParameterBindingType	A complex type value that specifies information about parameters that the Execute SQL Task uses as input or output.
ResultBinding	None.	SqlTaskResultBindingType	A complex type value that specifies information about the binding of the results of the execution of the Execute SQL Task.
BackupDestinationList	The BackupDestinationList element MUST NOT be used except with the Backup Task.	BackupDestinationListType	A complex type value that specifies information about the destinations for a Backup Task.

The following table specifies additional information for the attributes and the attribute groups of the **SqlTaskDataType** complex type.

Attribute or attribute group	Description
SqlTaskBaseAttributeGroup	An attribute group that specifies the attributes that are common to all SQL tasks.
MaintenanceTaskBaseAttributeGroup	An attribute group that specifies the attributes that are common to all maintenance tasks.
BackupTaskAttributeGroup	An attribute group that specifies the attributes for the Backup Task.
CheckIntegrityTaskAttributeGroup	An attribute group that specifies the attributes for the Check Integrity Task.
AgentJobTaskAttributeGroup	An attribute group that specifies the attributes for the Execute SQL Agent Job Task.
HistoryCleanupTaskAttributeGroup	An attribute group that specifies the attributes for the

Attribute or attribute group	Description
	History Cleanup Task.
MaintenanceFileCleanupTaskAttributeGroup	An attribute group that specifies the attributes for the Maintenance File Cleanup Task.
NotifyOperatorTaskAttributeGroup	An attribute group that specifies the attributes for the Notify Operator Task.
RebuildIndexTaskAttributeGroup	An attribute group that specifies the attributes for the Rebuild Index Task.
ReorganizeIndexTaskAttributeGroup	An attribute group that specifies the attributes for the Reorganize Index Task.
ShrinkDBTaskAttributeGroup	An attribute group that specifies the attributes for the Shrink Database Task.
UpdateStatisticsTaskAttributeGroup	An attribute group that specifies the attributes for the Update Statistics Task.
RemoveOlderThan	An integer value that specifies the number of units of time after which history is removed. The units for this integer value are specified by the TimeUnitsType attribute.
TimeUnitsType	An enumeration value that specifies the units of time for the RemoveOlderThan attribute.
DatabaseSelectionType	An enumeration value that specifies what types of databases are selected or whether a list of databases is specified.

2.7.1.11.1.1.1.1 SqlTaskDatabaseSelectionTypeEnum

The **SqlTaskDatabaseSelectionTypeEnum** type contains the enumeration values for the **SelectionType** attribute.

The following is the XSD for the **SqlTaskDatabaseSelectionTypeEnum** type.

```
<xs:simpleType name="SqlTaskDatabaseSelectionTypeEnum">
  <xs:restriction base="xs:int">
    <xs:minInclusive value="1"/>
    <xs:maxInclusive value="4"/>
  </xs:restriction>
</xs:simpleType>
```

The following table specifies the enumeration values for the **SqlTaskDatabaseSelectionTypeEnum** type.

Enumeration value	Description
1	Specifies that all databases are selected.
2	Specifies that only system databases are selected.

Enumeration value	Description
3	Specifies that all user databases are selected.
4	Specifies that the selected databases are specified by SelectedDatabases elements.

2.7.1.11.1.1.1.2 SqlTaskTimeUnitsTypeEnum

The **SqlTaskTimeUnitsTypeEnum** type contains the enumeration values for the **SelectionType** attribute.

The following is the XSD for the **SqlTaskTimeUnitsTypeEnum** type.

```
<xs:simpleType name="SqlTaskTimeUnitsTypeEnum">
  <xs:restriction base="xs:int">
    <xs:enumeration value="0"/>
    <xs:enumeration value="1"/>
    <xs:enumeration value="2"/>
    <xs:enumeration value="3"/>
    <xs:enumeration value="5"/>
  </xs:restriction>
</xs:simpleType>
```

The following table specifies the enumeration values for the **SqlTaskTimeUnitsTypeEnum** type.

Enumeration value	Description
0	The unit of time for the RemoveOlderThan attribute is days.
1	The unit of time for the RemoveOlderThan attribute is weeks.
2	The unit of time for the RemoveOlderThan attribute is months.
3	The unit of time for the RemoveOlderThan attribute is years.
5	The unit of time for the RemoveOlderThan attribute is hours.

2.7.1.11.1.1.1.3 SelectedDatabasesType

The **SelectedDatabasesType** complex type contains information about the databases that are selected for an Execute SQL Task data operation.

The following is the XSD for the **SelectedDatabasesType** complex type.

```
<xs:complexType name="SelectedDatabasesType">
  <xs:sequence/>
  <xs:attribute name="DatabaseName" type="xs:string"/>
</xs:complexType>
```

The **SelectedDatabasesType** complex type MUST NOT contain any elements or values.

The following table specifies the attributes of the **SelectedDatabasesType** complex type.

Attribute	Description
DatabaseName	A string value that contains the name of an existing database.

2.7.1.11.1.1.1.4 OperatorNotifyListType

The **OperatorNotifyListType** complex type contains information about the databases that are selected for an Execute SQL Task data operation.

The following is the XSD for the **OperatorNotifyListType** complex type.

```
<xs:complexType name="OperatorNotifyListType">
  <xs:sequence/>
  <xs:attribute name="OperatorNotify" type="xs:string"/>
</xs:complexType>
```

The **OperatorNotifyListType** complex type MUST NOT contain any elements or values.

The following table specifies the attributes of the **OperatorNotifyListType** complex type.

Attribute	Description
OperatorNotify	A string value that contains the name of an operator to notify.

2.7.1.11.1.1.1.5 SqlTaskParameterBindingType

The **SqlTaskParameterBindingType** complex type specifies information about the parameters that are used to execute an SQL statement.

The following is the XSD for the **SqlTaskParameterBindingType** complex type.

```
<xs:complexType name="SqlTaskParameterBindingType">
  <xs:sequence/>
  <xs:attribute name="ParameterName" type="xs:string"/>
  <xs:attribute name="DtsVariableName" type="xs:string"/>
  <xs:attribute name="ParameterDirection"
    type="SQLTask:ParameterDirectionEnum"/>
  <xs:attribute name="DataType" type="DTS:DtsDataTypeEnum"/>
  <xs:attribute name="ParameterSize" type="xs:int"/>
</xs:complexType>
```

The **SqlTaskParameterBindingType** complex type MUST NOT contain any elements or values.

The following table specifies the attributes of the **SqlTaskParameterBindingType** complex type.

Attribute	Description
ParameterName	A string value that specifies the name of the parameter. The format of this string value varies with the provider.

Attribute	Description
DtsVariableName	A string value that specifies the name of a DTS variable that provides an input value as the parameter value, receives an output value from the SQL execution, or receives a return value from the SQL execution.
ParameterDirection	An enumeration value that specifies the direction for the parameter.
Data Type	An enumeration value that specifies the data type of the parameter.
ParameterSize	An integer value that specifies the size of the parameter. Whether a parameter needs a size specified depends on the type of the parameter and the requirement of the provider.

2.7.1.11.1.1.1.5.1 ParameterDirectionEnum

The **ParameterDirectionEnum** type contains the enumeration values for the **ParameterDirection** attribute.

The following is the XSD for the **ParameterDirectionEnum** type.

```
<xs:simpleType name="ParameterDirectionEnum">
  <xs:restriction base="xs:string">
    <xs:enumeration value="Input"/>
    <xs:enumeration value="Output"/>
    <xs:enumeration value="ReturnValue"/>
  </xs:restriction>
</xs:simpleType>
```

The following table specifies the enumeration values for the **ParameterDirectionEnum** type.

Enumeration value	Description
Input	Specifies that the parameter provides input to the Execute SQL Task.
Output	Specifies that the parameter receives output from the Execute SQL Task.
ReturnValue	Specifies that the parameter receives a return value from the Execute SQL Task.

2.7.1.11.1.1.1.6 BackupDestinationListType

The **BackupDestinationListType** complex type specifies a list of backup destinations.

The following is the XSD for the **BackupDestinationListType** complex type.

```
<xs:complexType name="BackupDestinationListType">
  <xs:sequence/>
  <xs:attribute name="BackupDestinationLocation"
    type="xs:string"/>
</xs:complexType>
```

The **BackupDestinationListType** complex type MUST NOT contain any elements or values.

The following table specifies the attributes of the **BackupDestinationListType** complex type.

Attribute	Description
BackupDestinationLocation	A string value that specifies the destination location for the backup.

2.7.1.11.1.1.1.7 SqlTaskResultBindingType

The **SqlTaskResultBindingType** complex type specifies information about parameters that are used to execute an SQL statement.

The following is the XSD for the **SqlTaskResultBindingType** complex type.

```
<xs:complexType name="SqlTaskResultBindingType">
  <xs:sequence/>
  <xs:attribute name="ResultName" type="xs:string"/>
  <xs:attribute name="DtsVariableName" type="xs:string"/>
</xs:complexType>
```

The **SqlTaskResultBindingType** complex type MUST NOT contain any elements or values.

The following table specifies the attributes of the **SqlTaskResultBindingType** complex type.

Attribute	Description
ResultName	A string value that specifies the name of the result. The format of this string value varies with the provider.
DtsVariableName	A string value that specifies the name of a DTS variable that receives the result.

2.7.1.11.1.1.1.8 SqlTaskBaseAttributeGroup

The **SqlTaskBaseAttributeGroup** attribute group specifies the attributes that are used by the [SqlTaskData](#) element for all tasks that use the **SqlTaskData** element.

The following is the XSD for the **SqlTaskBaseAttributeGroup** attribute group.

```
<xs:attributeGroup name="SqlTaskBaseAttributeGroup">
  <xs:attribute name="Connection" type="DTS:uuid" use="optional"
    default=""/>
  <xs:attribute name="Timeout" type="xs:int" use="optional" default="0"/>
  <xs:attribute name="IsStoredProc" use="optional" default="False">
    <xs:simpleType>
      <xs:restriction base="xs:string">
        <xs:enumeration value="True"/>
        <xs:enumeration value="False"/>
      </xs:restriction>
    </xs:simpleType>
  </xs:attribute>
  <xs:attribute name="BypassPrepare" use="optional" default="True">
    <xs:simpleType>
      <xs:restriction base="xs:string">
        <xs:enumeration value="True"/>
        <xs:enumeration value="False"/>
      </xs:restriction>
    </xs:simpleType>
  </xs:attribute>
</xs:attributeGroup>
```

```

    </xs:simpleType>
  </xs:attribute>
  <xs:attribute name="SqlStmtSourceType"
    type="DTS:SourceTypeEnum"
    use="optional" default="DirectInput"/>
  <xs:attribute name="SqlStatementSource" type="xs:string"
    use="optional" default=""/>
  <xs:attribute name="CodePage" type="xs:int" use="optional"/>
  <xs:attribute name="ResultType"
    type="SQLTask:SqlResultTypeEnum"
    use="optional" default="ResultSetType_None"/>
</xs:attributeGroup>

```

The following table specifies additional information for the attributes of the **SqlTaskBaseAttributeGroup** attribute group.

Attribute	Description
Connection	A string value that specifies a reference to a connection manager by its DTSID property value or by its ObjectName property value.
TimeOut	An integer that specifies the timeout interval, in seconds, for the task.
IsStoredProc	An enumeration value that specifies whether the Execute SQL Task executes a stored procedure. "True" specifies that the task executes a stored procedure. "False" specifies that the task does not execute a stored procedure.
BypassPrepare	An enumeration value that specifies whether the SQL statement is prepared before the SQL statement is executed. "True" specifies that the prepare step is bypassed and that the task is not prepared before it is executed. "False" specifies that the prepare step is not bypassed and that the task is prepared before it is executed.
SqlStatementSourceType	This enumeration value specifies the source of the SQL statement.
SqlStatementSource	This string value specifies the SQL statement. The string value can contain an SQL language statement, or it can contain identifying information for the source of the SQL statement. The content depends on the value of the SqlStatementSourceType attribute.
CodePage	This integer value specifies the code page for the task. <96>
ResultType	This enumeration value specifies the form of the output from the task.

2.7.1.11.1.1.1.8.1 SqlResultTypeEnum

The **SqlResultTypeEnum** type contains the enumeration values for the **SqlResultType** attribute.

The following is the XSD for the **SqlResultTypeEnum** type.

```

<xs:simpleType name="SqlResultTypeEnum">
  <xs:restriction base="xs:string">
    <xs:enumeration value="ResultSetType_None"/>
  </xs:restriction>
</xs:simpleType>

```

```

    <xs:enumeration value="ResultSetType_Rowset" />
    <xs:enumeration value="ResultSetType_SingleRow" />
    <xs:enumeration value="ResultSetType_XML" />
  </xs:restriction>
</xs:simpleType>

```

The following table specifies the enumeration values for the **SqlResultTypeEnum** type.

Enumeration value	Description
ResultSetType_None	Specifies that no result set is returned.
ResultSetType_Rowset	Specifies that the result set that is returned is a rowset.
ResultSetType_SingleRow	Specifies that the result set that is returned is a single row.
ResultSetType_XML	Specifies that the result set that is returned is XML.

2.7.1.11.1.1.1.9 MaintenanceTaskBaseAttributeGroup

The **MaintenanceTaskBaseAttributeGroup** attribute group specifies the attributes that are used by the [SqlTaskData](#) element by all maintenance plan tasks. The attributes that are specified in this section MUST NOT be used unless the task is one of the maintenance plan tasks.

The following is the XSD for the **MaintenanceTaskBaseAttributeGroup** attribute group.

```

<xs:attributeGroup name="MaintenanceTaskBaseAttributeGroup">
  <xs:attribute name="ServerVersion" type="xs:int" />
  <xs:attribute name="ExtendedLogging">
    <xs:simpleType>
      <xs:restriction base="xs:string">
        <xs:enumeration value="True" />
        <xs:enumeration value="False" />
      </xs:restriction>
    </xs:simpleType>
  </xs:attribute>
  <xs:attribute name="LocalConnectionForLogging" type="xs:string" />
  <xs:attribute name="TaskName" type="xs:string" />
  <xs:attribute name="IgnoreDatabasesInNotOnlineState">
    <xs:simpleType>
      <xs:restriction base="xs:string">
        <xs:enumeration value="True" />
        <xs:enumeration value="False" />
      </xs:restriction>
    </xs:simpleType>
  </xs:attribute>
</xs:attributeGroup>

```

The following table specifies additional information for the attributes of the **MaintenanceTaskBaseAttributeGroup** attribute group.

Attribute	Description
ServerVersion	An integer value that specifies the server version.

Attribute	Description
ExtendedLogging	An enumeration value that specifies whether to include additional information about server operation at the end of a successful execution of a maintenance task in the log file. "True" specifies that additional information is included in the log file. "False" specifies that additional information is not included in the log file.
LocalConnectionForLogging	A string value that specifies a local connection manager that is used for logging. The string can reference the connection manager by pointing to the DTSID property of the connection manager or to the ObjectName property of the connection manager.
TaskName	A string value that specifies the name of the task.
IgnoreDatabasesInNotOnlineState	An enumeration value that specifies whether databases that are not in the online state are ignored. "True" specifies that databases that are not in the online state are ignored. "False" specifies that databases that are not in the online state are not ignored.

2.7.1.11.1.1.10 BackupTaskAttributeGroup

The **BackupTaskAttributeGroup** attribute group specifies the attributes that are used by the [SqlTaskData](#) element when the **ExecutableType** attribute of the containing [Executable](#) element is equal to the following value:

Microsoft.SqlServer.Management.DatabaseMaintenance.DbMaintenanceBackupTask,
Microsoft.SqlServer.MaintenancePlanTasks, Version=11.0.0.0, Culture=neutral,
PublicKeyToken=89845dcd8080cc91

The attributes that are specified in this section MUST NOT be used unless the **ExecutableType** attribute is equal to this value.

The following is the XSD for the **BackupTaskAttributeGroup** attribute group.

```
<xs:attributeGroup name="BackupTaskAttributeGroup">
  <xs:attribute name="BackupAction" type="SQLTask:BackupActionEnum"/>
  <xs:attribute name="BackupIsIncremental">
    <xs:simpleType>
      <xs:restriction base="xs:string">
        <xs:enumeration value="True"/>
        <xs:enumeration value="False"/>
      </xs:restriction>
    </xs:simpleType>
  </xs:attribute>
  <xs:attribute name="BackupFileGroupsFiles" type="xs:string"/>
  <xs:attribute name="BackupDeviceType"
    type="SQLTask:BackupDeviceTypeEnum"/>
  <xs:attribute name="BackupPhysicalDestinationType"
    type="SQLTask:BackupDeviceTypeEnum"/>
</xs:attributeGroup>
```

```

<xs:attribute name="BackupDestinationType"
              type="SQLTask:DestinationTypeEnum"/>
<xs:attribute name="BackupDestinationAutoFolderPath"
              type="xs:string"/>
<xs:attribute name="BackupActionForExistingBackups"
              type="SQLTask:BackupActionForExistingBackupsEnum"/>
<xs:attribute name="BackupCreateSubFolder">
  <xs:simpleType>
    <xs:restriction base="xs:string">
      <xs:enumeration value="True"/>
      <xs:enumeration value="False"/>
    </xs:restriction>
  </xs:simpleType>
</xs:attribute>
<xs:attribute name="BackupFileExtension" type="xs:string"/>
<xs:attribute name="BackupVerifyIntegrity">
  <xs:simpleType>
    <xs:restriction base="xs:string">
      <xs:enumeration value="True"/>
      <xs:enumeration value="False"/>
    </xs:restriction>
  </xs:simpleType>
</xs:attribute>
<xs:attribute name="ExpireDate" type="xs:dateTime"/>
<xs:attribute name="RetainDays" type="xs:int"/>
<xs:attribute name="InDays">
  <xs:simpleType>
    <xs:restriction base="xs:string">
      <xs:enumeration value="True"/>
      <xs:enumeration value="False"/>
    </xs:restriction>
  </xs:simpleType>
</xs:attribute>
<xs:attribute name="UseExpiration">
  <xs:simpleType>
    <xs:restriction base="xs:string">
      <xs:enumeration value="True"/>
      <xs:enumeration value="False"/>
    </xs:restriction>
  </xs:simpleType>
</xs:attribute>
<xs:attribute name="BackupCompressionAction"
              type="SQLTask:BackupCompressionEnum"/>
<xs:attribute name="BackupTailLog">
  <xs:simpleType>
    <xs:restriction base="xs:string">
      <xs:enumeration value="True"/>
      <xs:enumeration value="False"/>
    </xs:restriction>
  </xs:simpleType>
</xs:attribute>
</xs:attributeGroup>

```

The following table specifies additional information for the attributes of the **BackupTaskAttributeGroup** attribute group.

Attribute	Description
BackupAction	An enumeration value that specifies the action to be taken by the Backup Task.
BackupIsIncremental	An enumeration value that specifies whether the backup is incremental. "True" specifies that the backup is incremental. "False" specifies that the backup is not incremental.
BackupFileGroupsFiles	A string value that specifies the names of files or file groups that are to be backed up. Multiple names are specified as a comma-separated list.
BackupDeviceType	An enumeration value that specifies the type of device that the backup is output to.
BackupPhysicalDestinationType	An enumeration value that specifies the type of device that the backup is output to. If the value is 1 (tape), then no rewind or unload of the backup tape is issued after the completion of the backup.
BackupDestinationType	An enumeration value that specifies the type of the destination for the backup.
BackupDestinationAutoFolderPath	A string value that specifies a folder path where further folders are created for the backup output.
BackupActionForExistingBackups	An enumeration value that specifies the action to take if an existing backup exists at the destination.
BackupCreateSubFolder	An enumeration value that specifies whether to create subfolders for the backups. "True" specifies that subfolders are created. "False" specifies that subfolders are not created.
BackupFileExtension	A string value that specifies the file extension for files that are created by the backup.
BackupVerifyIntegrity	An enumeration value that specifies whether the task verifies the integrity of the backup after the backup file is created. "True" specifies that the task verifies the integrity of the backup file that is created. "False" specifies that the task does not verify the integrity of the backup file that is created.
ExpireDate	A date/time value that specifies the expiration date for the backup.
RetainDays	An integer value that specifies a number of days until the backup expires.
InDays	An enumeration value that specifies whether to use the ExpireDate attribute value or the RetainDays attribute value for the expiration of the backup. "True" specifies that the RetainDays attribute value is used to determine the backup expiration. "False" specifies that the ExpireDate attribute value is used to

Attribute	Description
	determine the backup expiration.
UseExpiration	An enumeration value that specifies whether the backup expires. "True" specifies that the backup expires. "False" specifies that the backup does not expire.
BackupCompressionAction	An enumeration value that specifies whether the backup is compressed, the backup is not compressed, or the default compression setting is used.
BackupTailLog	An enumeration value that specifies whether the Backup Task backs up the tail of the log at the end of the task. "True" specifies that the tail of the log is backed up at the end of the backup task. "False" specifies that the tail of the log is not backed up at the end of the backup task.

2.7.1.11.1.1.1.10.1 BackupActionEnum

The **BackupActionEnum** type contains the enumeration values for the **BackupAction** attribute.

The following is the XSD for the **BackupActionEnum** type.

```
<xs:simpleType name="BackupActionEnum">
  <xs:restriction base="xs:int">
    <xs:minInclusive value="0"/>
    <xs:maxInclusive value="2"/>
  </xs:restriction>
</xs:simpleType>
```

The following table specifies the enumeration values for the **BackupActionEnum** type.

Enumeration value	Description
0	Back up a database.
1	Back up files.
2	Back up a transaction log.

2.7.1.11.1.1.1.10.2 BackupDeviceTypeEnum

The **BackupDeviceTypeEnum** type contains the enumeration values for the **BackupDeviceType** attribute.

The following is the XSD for the **BackupDeviceTypeEnum** type.

```
<xs:simpleType name="BackupDeviceTypeEnum">
  <xs:restriction base="xs:int">
    <xs:minInclusive value="0"/>
    <xs:maxInclusive value="4"/>
  </xs:restriction>
</xs:simpleType>
```

```

    </xs:restriction>
  </xs:simpleType>

```

The following table specifies the enumeration values for the **BackupDeviceTypeEnum** type.

Enumeration value	Description
0	Specifies that the backup device is a logical device.
1	Specifies that the backup device is a tape.
2	Specifies that the backup device is a file.
3	Specifies that the backup device is a pipe.
4	Specifies that the backup device is a virtual device.

2.7.1.11.1.1.1.10.3 DestinationTypeEnum

The **DestinationTypeEnum** type contains the enumeration values for the **DestinationType** attribute.

The following is the XSD for the **DestinationTypeEnum** type.

```

<xs:simpleType name="DestinationTypeEnum">
  <xs:restriction base="xs:int">
    <xs:minInclusive value="0"/>
    <xs:maxInclusive value="1"/>
  </xs:restriction>
</xs:simpleType>

```

The following table specifies the enumeration values for the **DestinationTypeEnum** type.

Enumeration value	Description
0	Specifies that the destination is automatically determined by the task.
1	Specifies that the destination is manually set by the user.

2.7.1.11.1.1.1.10.4 BackupActionForExistingBackupsEnum

The **BackupActionForExistingBackupsEnum** type contains the enumeration values for the **BackupActionForExistingBackups** attribute.

The following is the XSD for the **BackupActionForExistingBackupsEnum** type.

```

<xs:simpleType name="BackupActionForExistingBackupsEnum">
  <xs:restriction base="xs:int">
    <xs:minInclusive value="0"/>
    <xs:maxInclusive value="1"/>
  </xs:restriction>

```

```
</xs:simpleType>
```

The following table specifies the enumeration values for the **BackupActionForExistingBackupsEnum** type.

Enumeration value	Description
0	Specifies that existing backups are appended to.
1	Specifies that existing backups are overwritten.

2.7.1.11.1.1.1.10.5 BackupCompressionActionEnum

The **BackupCompressionActionEnum** type contains the enumeration values for the **CompressionAction** attribute.

The following is the XSD for the **BackupCompressionActionEnum** type.

```
<xs:simpleType name="BackupActionForExistingBackupsEnum">  
  <xs:restriction base="xs:int">  
    <xs:minInclusive value="0"/>  
    <xs:maxInclusive value="1"/>  
  </xs:restriction>  
</xs:simpleType>
```

The following table specifies the enumeration values for the **BackupCompressionActionEnum** type.

Enumeration value	Description
0	Specifies that the default setting for compression is used.
1	Specifies that backups are compressed.
2	Specifies that backups are not compressed.

2.7.1.11.1.1.1.11 CheckIntegrityTaskAttributeGroup

The **CheckIntegrityTaskAttributeGroup** attribute group specifies the attributes that are used by the [SqlTaskData](#) element when the **ExecutableType** attribute of the containing [Executable](#) element is equal to the following value:

Microsoft.SqlServer.Management.DatabaseMaintenance.DbMaintenanceCheckIntegrityTask,
Microsoft.SqlServer.MaintenancePlanTasks, Version=11.0.0.0, Culture=neutral,
PublicKeyToken=89845dcd8080cc91

The attributes that are specified in this section MUST NOT be used unless the **ExecutableType** attribute is equal to this value.

The following is the XSD for the **CheckIntegrityTaskAttributeGroup** attribute group.

```

<xs:attributeGroup name="CheckIntegrityTaskAttributeGroup">
  <xs:attribute name="IncludeIndexes">
    <xs:simpleType>
      <xs:restriction base="xs:string">
        <xs:enumeration value="True"/>
        <xs:enumeration value="False"/>
      </xs:restriction>
    </xs:simpleType>
  </xs:attribute>
</xs:attributeGroup>

```

The following table specifies additional information for the attributes of the **CheckIntegrityTaskAttributeGroup** attribute group.

Attribute	Description
IncludeIndexes	An enumeration value that specifies whether to check the integrity of all indexes in addition to the table data pages. "True" specifies that the integrity of all indexes is checked in addition to the table data pages. "False" specifies that the integrity of only the table data pages is checked.

2.7.1.11.1.1.1.12 AgentJobTaskAttributeGroup

The **AgentJobTaskAttributeGroup** attribute group specifies the attributes that are used by the [SqlTaskData](#) element when the **ExecutableType** attribute of the containing [Executable](#) element is equal to the following value:

```

Microsoft.SqlServer.Management.DatabaseMaintenance.DbMaintenanceExecuteAgentJobTask,
Microsoft.SqlServer.MaintenancePlanTasks, Version=11.0.0.0, Culture=neutral,
PublicKeyToken=89845dcd8080cc91

```

The attributes that are specified in this section MUST NOT be used unless the **ExecutableType** attribute is equal to this value.

The following is the XSD for the **AgentJobTaskAttributeGroup** attribute group.

```

<xs:attributeGroup name="AgentJobTaskAttributeGroup">
  <xs:attribute name="AgentJobID" type="xs:string"/>
</xs:attributeGroup>

```

The following table specifies additional information for the attributes of the **AgentJobTaskAttributeGroup** attribute group.

Attribute	Description
AgentJobID	A string value that specifies the Job ID for the Execute SQL Agent Job Task.

2.7.1.11.1.1.1.13 HistoryCleanupTaskAttributeGroup

The **HistoryCleanupTaskAttributeGroup** attribute group specifies the attributes that are used by the [SqlTaskData](#) element when the **ExecutableType** attribute of the containing [Executable](#) element is equal to the following value:

Microsoft.SqlServer.Management.DatabaseMaintenance.DbMaintenanceHistoryCleanupTask,
Microsoft.SqlServer.MaintenancePlanTasks, Version=11.0.0.0, Culture=neutral,
PublicKeyToken=89845dcd8080cc91

The attributes that are specified in this section MUST NOT be used unless the **ExecutableType** attribute is equal to this value.

The following is the XSD for the **HistoryCleanupTaskAttributeGroup** attribute group.

```
<xs:attributeGroup name="HistoryCleanupTaskAttributeGroup">
  <xs:attribute name="RemoveBackupRestoreHistory">
    <xs:simpleType>
      <xs:restriction base="xs:string">
        <xs:enumeration value="True"/>
        <xs:enumeration value="False"/>
      </xs:restriction>
    </xs:simpleType>
  </xs:attribute>
  <xs:attribute name="RemoveAgentHistory">
    <xs:simpleType>
      <xs:restriction base="xs:string">
        <xs:enumeration value="True"/>
        <xs:enumeration value="False"/>
      </xs:restriction>
    </xs:simpleType>
  </xs:attribute>
  <xs:attribute name="RemoveDbMaintHistory">
    <xs:simpleType>
      <xs:restriction base="xs:string">
        <xs:enumeration value="True"/>
        <xs:enumeration value="False"/>
      </xs:restriction>
    </xs:simpleType>
  </xs:attribute>
</xs:attributeGroup>
```

The following table specifies additional information for the attributes of the **HistoryCleanupTaskAttributeGroup** attribute group.

Attribute	Description
RemoveBackupRestoreHistory	An enumeration value that specifies whether the History Cleanup Task removes the backup restore history. "True" specifies that the History Cleanup Task removes the backup restore history. "False" specifies that the History Cleanup Task does not remove the backup restore history.
RemoveAgentHistory	An enumeration value that specifies whether the History Cleanup Task

Attribute	Description
	<p>removes the SQL agent history.</p> <p>"True" specifies that the History Cleanup Task removes the SQL agent history.</p> <p>"False" specifies that the History Cleanup Task does not remove the SQL agent history.</p>
RemoveDBMaintHistory	<p>An enumeration value that specifies whether the History Cleanup Task removes database maintenance history.</p> <p>"True" specifies that the History Cleanup Task removes the database maintenance history.</p> <p>"False" specifies that the History Cleanup Task does not remove the database maintenance history.</p>

2.7.1.11.1.1.1.14 MaintenanceFileCleanupTaskAttributeGroup

The **MaintenanceFileCleanupTaskAttributeGroup** attribute group specifies the attributes that are used by the [SqlTaskData](#) element when the **ExecutableType** attribute of the containing [Executable](#) element is equal to the following value:

Microsoft.SqlServer.Management.DatabaseMaintenance.DbMaintenanceFileCleanupTask, Microsoft.SqlServer.MaintenancePlanTasks, Version=11.0.0.0, Culture=neutral, PublicKeyToken=89845dcd8080cc91

The attributes that are specified in this section MUST NOT be used unless the **ExecutableType** attribute is equal to this value.

The following is the XSD for the **MaintenanceFileCleanupTaskAttributeGroup** attribute group.

```
<xs:attributeGroup name="MaintenanceFileCleanupTaskAttributeGroup">
  <xs:attribute name="FileTypeSelected" type="xs:string"/>
  <xs:attribute name="FilePath" type="xs:string"/>
  <xs:attribute name="FolderPath" type="xs:string"/>
  <xs:attribute name="CleanSubFolders">
    <xs:simpleType>
      <xs:restriction base="xs:string">
        <xs:enumeration value="True"/>
        <xs:enumeration value="False"/>
      </xs:restriction>
    </xs:simpleType>
  </xs:attribute>
  <xs:attribute name="FileExtension" type="xs:string"/>
  <xs:attribute name="AgeBased">
    <xs:simpleType>
      <xs:restriction base="xs:string">
        <xs:enumeration value="True"/>
        <xs:enumeration value="False"/>
      </xs:restriction>
    </xs:simpleType>
  </xs:attribute>
  <xs:attribute name="DeleteSpecificFile">
    <xs:simpleType>
      <xs:restriction base="xs:string">
        <xs:enumeration value="True"/>
      </xs:restriction>
    </xs:simpleType>
  </xs:attribute>
</xs:attributeGroup>
```

```

    <xs:enumeration value="False"/>
  </xs:restriction>
</xs:simpleType>
</xs:attribute>
</xs:attributeGroup>

```

The following table specifies additional information for the attributes of the **MaintenanceFileCleanupTaskAttributeGroup** attribute group.

Attribute	Description
FileTypeSelected	An enumeration value that specifies the type of the files that are selected to be deleted.
FilePath	A string value that contains the path and the name of the file to be deleted.
FolderPath	A string value that contains the path and the name of the folder that contains the files to be deleted.
CleanSubFolders	An enumeration value that specifies whether the task removes files in first-level subfolders to the folder that is specified in the FolderPath attribute. "True" specifies that the task removes files in first-level subfolders to the folder that is specified in the FolderPath attribute. "False" specifies that the task does not remove files in first-level subfolders to the folder specified in the FolderPath attribute.
FileExtension	A string value that specifies the file extension for the files to be deleted.
AgeBased	An enumeration value that specifies whether the task deletes all files of the specified type that are older than the age that is specified in the RemoveOlderThan attribute. "True" specifies that the task removes all files of the specified type that are older than the specified age. "False" specifies that the task does not remove files of the specified type that are older than the specified age.
DeleteSpecificFile	An enumeration value that specifies whether the task deletes a specific file that is specified in the FilePath attribute. "True" specifies that the task deletes a specific file that is specified in the FilePath attribute. "False" specifies that the task does not delete a specific file that is specified in the FilePath attribute.

2.7.1.11.1.1.1.14.1 SqlTaskFileTypeSelectedEnum

The **SqlTaskFileTypeSelectedEnum** type contains the enumeration values for the **FileTypeSelected** attribute.

The following is the XSD for the **SqlTaskFileTypeSelectedEnum** type.

```

<xs:simpleType name="SqlTaskFileTypeSelectedEnum">
  <xs:restriction base="xs:int">
    <xs:minInclusive value="0"/>
    <xs:maxInclusive value="1"/>
  </xs:restriction>
</xs:simpleType>

```



```

    </xs:restriction>
  </xs:simpleType>

```

The following table specifies the enumeration values for the **SqlTaskFileTypeSelectedEnum** type.

Enumeration value	Description
0	Specifies that backup files are selected for removal.
1	Specifies that maintenance plan text reports are selected for removal.

2.7.1.11.1.1.1.15 NotifyOperatorTaskAttributeGroup

The **NotifyOperatorTaskAttributeGroup** attribute groups specifies the attributes that are used by the [SqlTaskData](#) element when the **ExecutableType** attribute of the containing [Executable](#) element is equal to the following value:

Microsoft.SqlServer.Management.DatabaseMaintenance.DbMaintenanceNotifyOperatorTask,
 Microsoft.SqlServer.MaintenancePlanTasks, Version=11.0.0.0, Culture=neutral,
 PublicKeyToken=89845dcd8080cc91

The attributes that are specified in this section MUST NOT be used unless the **ExecutableType** attribute is equal to this value.

The following is the XSD for the **NotifyOperatorTaskAttributeGroup** attribute group.

```

<xs:attributeGroup name="NotifyOperatorTaskAttributeGroup">
  <xs:attribute name="Message" type="xs:string"/>
  <xs:attribute name="Profile" type="xs:string"/>
  <xs:attribute name="Subject" type="xs:string"/>
</xs:attributeGroup>

```

The following table specifies additional information for the attributes of the **NotifyOperatorTaskAttributeGroup** attribute group.

Attribute	Description
Message	A string value that contains the message text for the operator notification.
Profile	The name of the database mail profile to send to.
Subject	A string value that contains the subject line text for the operator notification.

2.7.1.11.1.1.1.16 RebuildIndexTaskAttributeGroup

The **RebuildIndexTaskAttributeGroup** attribute group specifies the attributes that are used by the [SqlTaskData](#) element when the **ExecutableType** attribute of the containing [Executable](#) element is equal to the following value:

Microsoft.SqlServer.Management.DatabaseMaintenance.DbMaintenanceReindexTask,
 Microsoft.SqlServer.MaintenancePlanTasks, Version=11.0.0.0, Culture=neutral,
 PublicKeyToken=89845dcd8080cc91

The attributes that are specified in this section MUST NOT be used unless the **ExecutableType** attribute is equal to this value.

The following is the XSD for the **RebuildIndexTaskAttributeGroup** attribute group.

```
<xs:attributeGroup name="RebuildIndexTaskAttributeGroup">
  <xs:attribute name="UseOriginalAmount">
    <xs:simpleType>
      <xs:restriction base="xs:string">
        <xs:enumeration value="True"/>
        <xs:enumeration value="False"/>
      </xs:restriction>
    </xs:simpleType>
  </xs:attribute>
  <xs:attribute name="Percentage" type="xs:int"/>
  <xs:attribute name="Sort">
    <xs:simpleType>
      <xs:restriction base="xs:string">
        <xs:enumeration value="True"/>
        <xs:enumeration value="False"/>
      </xs:restriction>
    </xs:simpleType>
  </xs:attribute>
  <xs:attribute name="KeepOnline">
    <xs:simpleType>
      <xs:restriction base="xs:string">
        <xs:enumeration value="True"/>
        <xs:enumeration value="False"/>
      </xs:restriction>
    </xs:simpleType>
  </xs:attribute>
</xs:attributeGroup>
```

The following table specifies additional information for the attributes of the **RebuildIndexTaskAttributeGroup** attribute group.

Attribute	Description
UseOriginalAmount	An enumeration value that specifies that the indexes are rebuilt with the same amount of free space as was allocated when the index was created. "True" specifies that indexes are rebuilt with the amount of free space that was allocated when the index was created. "False" specifies that indexes are not rebuilt with the amount of free space that was allocated when the index was created.
Percentage	An integer value that specifies the percentage of free space to allocate in the rebuilt indexes.
Sort	An enumeration value that specifies whether sorts that are required during the rebuild index operation are performed in a temporary database. "True" specifies that any sorts that are required during the rebuild index operation are performed in a temporary database. "False" specifies that any sorts that are required during the rebuild index operation are not performed in a temporary database.

Attribute	Description
KeepOnline	An enumeration value that specifies whether the database is to be kept online during the rebuild index operation. "True" specifies that the index is to be kept online during the rebuild index operation. "False" specifies that the index is not to be kept online during the rebuild index operation.

2.7.1.11.1.1.1.17 ReorganizeIndexTaskAttributeGroup

The **ReorganizeIndexTaskAttributeGroup** attribute group specifies the attributes that are utilized by the [SqlTaskData](#) element when the **ExecutableType** attribute of the containing [Executable](#) element is equal to the following value:

Microsoft.SqlServer.Management.DatabaseMaintenance.DbMaintenanceDefragmentIndexTask, Microsoft.SqlServer.MaintenancePlanTasks, Version=11.0.0.0, Culture=neutral, PublicKeyToken=89845dcd8080cc91

The attributes that are specified in this section MUST NOT be used unless the **ExecutableType** attribute is equal to this value.

The following is the XSD for the **ReorganizeIndexTaskAttributeGroup** attribute group.

```
<xs:attributeGroup name="ReorganizeIndexTaskAttributeGroup">
  <xs:attribute name="CompactLargeObjects">
    <xs:simpleType>
      <xs:restriction base="xs:string">
        <xs:enumeration value="True"/>
        <xs:enumeration value="False"/>
      </xs:restriction>
    </xs:simpleType>
  </xs:attribute>
</xs:attributeGroup>
```

The following table specifies additional information for the attributes of the **ReorganizeIndexTaskAttributeGroup** attribute group.

Attribute	Description
CompactLargeObjects	An enumeration value that specifies whether space for tables and views should be deallocated when possible. "True" specifies that space for tables and views should be deallocated when possible. "False" specifies that large objects are not compacted by the task.

2.7.1.11.1.1.1.18 ShrinkDBTaskAttributeGroup

The **ShrinkDBTaskAttributeGroup** attribute group specifies the attributes that are used by the [SqlTaskData](#) element when the **ExecutableType** attribute of the containing [Executable](#) element is equal to the following value:

Microsoft.SqlServer.Management.DatabaseMaintenance.DbMaintenanceShrinkTask,
 Microsoft.SqlServer.MaintenancePlanTasks, Version=11.0.0.0, Culture=neutral,
 PublicKeyToken=89845dcd8080cc91

The attributes that are specified in this section MUST NOT be used unless the **ExecutableType** attribute is equal to this value.

The following is the XSD for the **ShrinkDBTaskAttributeGroup** attribute group.

```
<xs:attributeGroup name="ShrinkDBTaskAttributeGroup">
  <xs:attribute name="DatabaseSizeLimit" type="xs:int"/>
  <xs:attribute name="DatabasePercentLimit" type="xs:int"/>
  <xs:attribute name="DatabaseReturnFreeSpace">
    <xs:simpleType>
      <xs:restriction base="xs:string">
        <xs:enumeration value="True"/>
        <xs:enumeration value="False"/>
      </xs:restriction>
    </xs:simpleType>
  </xs:attribute>
</xs:attributeGroup>
```

The following table specifies additional information for the attributes of the **ShrinkDBTaskAttributeGroup** attribute group.

Attribute	Description
DatabaseSizeLimit	An integer that specifies the size limit of the database in megabytes.
DatabasePercentLimit	An integer that specifies the limit of free space in units of percentage. When free space in the database falls below the percentage represented by the integer value, shrinking of the database stops.
DatabaseReturnFreeSpace	An enumeration value that specifies whether to retain free space in the database file or to return it to the operating system. "True" specifies that free space is returned to the operating system. "False" specifies that free space is retained in the database file.

2.7.1.11.1.1.19 UpdateStatisticsTaskAttributeGroup

The **UpdateStatisticsTaskAttributeGroup** attribute group specifies the attributes that are used by the [SqlTaskData](#) element when the **ExecutableType** attribute of the containing [Executable](#) element is equal to "". The attributes that are specified in this section MUST NOT be used unless the **ExecutableType** attribute is equal to this value.

The following is the XSD for the **UpdateStatisticsTaskAttributeGroup** attribute group.

```
<xs:attributeGroup name="UpdateStatisticsTaskAttributeGroup">
  <xs:attribute name="UpdateStatisticsType"
    type="SQLTask:SqlTaskUpdateStatisticsTypeEnum"/>
  <xs:attribute name="UpdateScanType"
    type="SQLTask:SqlTaskUpdateScanTypeEnum"/>
  <xs:attribute name="UpdateSampleValue" type="xs:int"/>
</xs:attributeGroup>
```

```
</xs:attributeGroup>
```

The following table specifies additional information for the attributes of the **UpdateStatisticsTaskAttributeGroup** attribute group.

Attribute	Description
UpdateStatisticsType	An enumeration value that specifies the database objects that have updated statistics.
UpdateScanType	An enumeration value that specifies the type of scan to perform for statistics gathering.
UpdateSampleValue	An integer value for which the interpretation is based upon the value of the UpdateScanType attribute. This integer value can represent a percentage or a count of rows.

2.7.1.11.1.1.1.19.1 SqlTaskUpdateStatisticsTypeEnum

The **SqlTaskUpdateStatisticsTypeEnum** type contains the enumeration values for the **UpdateStatisticsType** attribute.

The following is the XSD for the **SqlTaskUpdateStatisticsTypeEnum** type.

```
<xs:simpleType name="SqlTaskUpdateStatisticsTypeEnum">  
  <xs:restriction base="xs:int">  
    <xs:minInclusive value="0"/>  
    <xs:maxInclusive value="2"/>  
  </xs:restriction>  
</xs:simpleType>
```

The following table specifies the enumeration values for the **SqlTaskUpdateStatisticsTypeEnum** type.

Enumeration value	Description
0	Specifies that statistics are updated for indexes only.
1	Specifies that only column statistics are updated.
2	Specifies that all existing statistics are updated.

2.7.1.11.1.1.1.19.2 SqlTaskUpdateStatisticsTypeEnum

The **SqlTaskUpdateStatisticsTypeEnum** type contains the enumeration values for the **UpdateStatisticsType** attribute.

The following is the XSD for the **TheSqlTaskUpdateStatisticsTypeEnum** type.

```
<xs:simpleType name="SqlTaskUpdateStatisticsTypeEnum">  
  <xs:restriction base="xs:int">  
    <xs:minInclusive value="0"/>  
  </xs:restriction>  
</xs:simpleType>
```

```

    <xs:maxInclusive value="2"/>
  </xs:restriction>
</xs:simpleType>

```

The following table specifies the enumeration values for the **SqlTaskUpdateStatisticsTypeEnum** type.

Enumeration value	Description
0	Specifies that statistics are updated for indexes only.
1	Specifies that only column statistics are updated.
2	Specifies that all existing statistics are updated.

2.7.1.11.1.1.20 Execute TSQL Task

The Execute TSQL Task has no attributes that it adds to the [SqlTaskData](#) element. When the **ExecutableType** attribute of the containing [Executable](#) element is equal to "Microsoft.SqlServer.Management.DatabaseMaintenance.DbMaintenanceTSQLExecuteTask, Microsoft.SqlServer.MaintenancePlanTasks, Version=11.0.0.0, Culture=neutral, PublicKeyToken=89845dcd8080cc91" there MUST NOT be any attributes for the **SqlTaskData** element beyond those that are specified in the [SqlTaskBaseAttributeGroup](#) attribute group and the [MaintenanceTaskBaseAttributeGroup](#) attribute group.

2.7.1.12 FileSystemDataObjectDataType

The **FileSystemDataObjectDataType** complex type is used to specify settings and parameters that are specific to the File System Task.

The following is the XSD for the **FileSystemDataObjectDataType** complex type.

```

<xs:complexType name="FileSystemDataObjectDataType">
  <xs:sequence/>
  <xs:attribute name="TaskOperationType" form="unqualified"
    type="DTS:FileSystemTaskOperationTypeEnum"
    use="optional" default="CopyFile"/>
  <xs:attribute name="OperationName" form="unqualified"
    type="xs:string" use="optional" default=""/>
  <xs:attribute name="TaskOverwriteDestFile" form="unqualified"
    use="optional" default="False">
    <xs:simpleType>
      <xs:restriction base="xs:string">
        <xs:enumeration value="False"/>
        <xs:enumeration value="True"/>
      </xs:restriction>
    </xs:simpleType>
  </xs:attribute>
  <xs:attribute name="TaskSourcePath" form="unqualified"
    type="xs:string" use="optional" default=""/>
  <xs:attribute name="TaskIsSourceVariable" form="unqualified"
    use="optional" default="False">
    <xs:simpleType>
      <xs:restriction base="xs:string">

```

```

        <xs:enumeration value="False"/>
        <xs:enumeration value="True"/>
    </xs:restriction>
</xs:simpleType>
</xs:attribute>
<xs:attribute name="TaskDestinationPath" form="unqualified"
    type="xs:string" use="optional" default=""/>
<xs:attribute name="TaskIsDestinationVariable" form="unqualified">
    <xs:simpleType>
        <xs:restriction base="xs:string">
            <xs:enumeration value="False"/>
            <xs:enumeration value="True"/>
        </xs:restriction>
    </xs:simpleType>
</xs:attribute>
<xs:attribute name="TaskFileAttributes" form="unqualified"
    type="DTS:FileSystemTaskFileAttributesEnum"
    use="optional" default="Normal"/>
</xs:complexType>

```

The **FileSystemDataObjectDataType** complex type MUST NOT have child elements.

The following table provides additional information about the attributes in the **FileSystemDataObjectDataType** complex type.

Attribute	Description
TaskOperationType	This enumeration value specifies the type of file system task that is performed.
OperationName	This string value contains the name given to the operation.
TaskOverwriteDestFile	This enumeration value specifies whether the destination file can be overwritten. "True" specifies that the destination file can be overwritten. "False" specifies that the destination file cannot be overwritten.
TaskSourcePath	This string value represents the source file path. It contains either the DTSID property of a defined ConnectionManager object or a string that contains the name of a variable.
TaskIsSourceVariable	This enumeration value specifies whether a variable or a file connection manager specifies the source path. "True" specifies that the TaskSourcePath is a variable. "False" specifies that the TaskSourcePath is a file connection manager.
TaskDestinationPath	This string value represents the destination file path. It contains either the DTSID property of a defined ConnectionManager object or a string that contains the name of a variable.
TaskIsDestinationVariable	This enumeration value specifies whether a variable or a file connection manager specifies the destination path. "True" specifies that the TaskDestinationPath value is a variable. "False" specifies that the TaskDestinationPath value is a file connection manager.

Attribute	Description
TaskFileAttributes	This enumeration value specifies the file attributes for the file system file.

2.7.1.12.1 FileSystemTaskOperationTypeEnum

The **FileSystemTaskOperationTypeEnum** type contains the allowed enumeration values for the **FileSystemTaskOperationType** attribute of the [FileSystemDataObjectDataType](#) type.

The following is the XSD for the **FileSystemTaskOperationTypeEnum** type.

```
<xs:simpleType name="FileSystemTaskOperationTypeEnum">
  <xs:restriction base="xs:string">
    <xs:enumeration value="CopyFile" />
    <xs:enumeration value="CreateDirectory" />
    <xs:enumeration value="DeleteDirectory" />
    <xs:enumeration value="DeleteFile" />
    <xs:enumeration value="MoveDirectory" />
    <xs:enumeration value="MoveFile" />
    <xs:enumeration value="RenameFile" />
    <xs:enumeration value="SetAttributes" />
    <xs:enumeration value="DeleteDirectoryContent" />
    <xs:enumeration value="CopyDirectory" />
  </xs:restriction>
</xs:simpleType>
```

The following table specifies the enumeration values for the **FileSystemTaskOperationTypeEnum** type.

Enumeration value	Description
CopyFile	Specifies that the task operation copies a file.
CreateDirectory	Specifies that the task operation creates a directory.
DeleteDirectory	Specifies that the task operation deletes a directory.
DeleteFile	Specifies that the task operation deletes a file.
MoveDirectory	Specifies that the task operation moves a directory.
MoveFile	Specifies that the task operation moves a file.
RenameFile	Specifies that the task operation renames a file.
SetAttributes	Specifies that the task operation sets attributes.
DeleteDirectoryContent	Specifies that the task operation deletes directory contents.
CopyDirectory	Specifies that the task operation copies a directory.

2.7.1.12.2 FileSystemTaskFileAttributesEnum

The **FileSystemTaskFileAttributesEnum** type contains the allowed enumeration values for the **TaskFileAttributes** attribute of the [FileSystemDataObjectDataType](#) type.

The following is the XSD for the **FileSystemTaskFileAttributesEnum** type.

```
<xs:simpleType name="FileSystemTaskFileAttributesEnum">
  <xs:restriction base="xs:string">
    <xs:enumeration value="Archive" />
    <xs:enumeration value="Hidden" />
    <xs:enumeration value="Normal" />
    <xs:enumeration value="ReadOnly" />
    <xs:enumeration value="System" />
  </xs:restriction>
</xs:simpleType>
```

The following table specifies the enumeration values for the **FileSystemTaskFileAttributesEnum** type.

Enumeration value	Description
Archive	This enumeration value specifies that the Archive attribute of the file MUST be set by the task.
Hidden	This enumeration value specifies that the Hidden attribute of the file MUST be set by the task.
Normal	This enumeration value specifies that the file is normal and that none of the file attributes MUST be set by the task.
ReadOnly	This enumeration value specifies that the ReadOnly attribute of the file MUST be set by the task.
System	This enumeration value specifies that the System attribute of the file MUST be set by the task.

2.7.1.13 FtpDataObjectDataType

The **FtpDataObjectDataType** complex type is used to specify parameters, properties, and settings that are specific to the FTP Task.

The following is the XSD of the **FtpDataObjectDataType** complex type.

```
<xs:complexType name="FtpDataObjectDataType">
  <xs:sequence>
  </xs:sequence>
  <xs:attribute name="ConnectionName" type="xs:string"
    use="optional" default="" form="unqualified"/>
  <xs:attribute name="StopOnFailure" form="unqualified">
    <xs:simpleType>
      <xs:restriction base="xs:string">
        <xs:enumeration value="False"/>
        <xs:enumeration value="True"/>
      </xs:restriction>
    </xs:simpleType>
  </xs:attribute>
  <xs:attribute name="TaskOperationType"
    type="DTS:FtpDataTaskOperationTypeEnum"/>
</xs:complexType>
```

```

        use="optional" default="Send" form="unqualified"/>
<xs:attribute name="TaskOperationName" type="xs:string"
        use="optional" default="" form="unqualified"/>
<xs:attribute name="TaskIsLocalPathVar" form="unqualified"
        use="optional" default="False">
  <xs:simpleType>
    <xs:restriction base="xs:string">
      <xs:enumeration value="False"/>
      <xs:enumeration value="True"/>
    </xs:restriction>
  </xs:simpleType>
</xs:attribute>
<xs:attribute name="TaskLocalPath" type="xs:string"
        use="optional" default="" form="unqualified"/>
<xs:attribute name="TaskIsRemotePathVar" form="unqualified"
        use="optional" default="False">
  <xs:simpleType>
    <xs:restriction base="xs:string">
      <xs:enumeration value="False"/>
      <xs:enumeration value="True"/>
    </xs:restriction>
  </xs:simpleType>
</xs:attribute>
<xs:attribute name="TaskRemotePath" type="xs:string"
        use="optional" default="" form="unqualified"/>
<xs:attribute name="TaskOverwriteDest" form="unqualified"
        use="optional" default="False">
  <xs:simpleType>
    <xs:restriction base="xs:string">
      <xs:enumeration value="False"/>
      <xs:enumeration value="True"/>
    </xs:restriction>
  </xs:simpleType>
</xs:attribute>
<xs:attribute name="TaskTransferAscii" form="unqualified"
        use="optional" default="False">
  <xs:simpleType>
    <xs:restriction base="xs:string">
      <xs:enumeration value="False"/>
      <xs:enumeration value="True"/>
    </xs:restriction>
  </xs:simpleType>
</xs:attribute>
</xs:complexType>

```

The **FtpDataObjectType** complex type MUST NOT contain elements.

The following table specifies the attributes of the **FtpDataObjectType** complex type.

Attribute	Description
ConnectionName	A string value that specifies a reference to a connection manager by its DTSID property value or by its ObjectName property value.
StopOnFailure	An enumeration value that specifies whether the task fails if the FTP operation fails. "True" specifies that the task fails if the FTP operation fails.

Attribute	Description
	"False" specifies that the task does not fail if the FTP operation fails.
TaskOperationType	An enumeration value that specifies the FTP operation that the task performs.
TaskOperationName	A string value that specifies a name that is given to the operation.
TaskIsLocalPathVar	An enumeration value that specifies whether the TaskLocalPath attribute contains the name of a variable. "True" specifies that the TaskLocalPath attribute contains a variable name. "False" specifies that the TaskLocalPath attribute does not contain a variable name.
TaskLocalPath	A string value that specifies the path in the local location or, if the TaskIsLocalPathVar attribute is equal to "True", a string value that specifies the name of the variable.
TaskIsRemotePathVar	An enumeration value that specifies whether the TaskRemotePath attribute contains the name of a variable. "True" specifies that the TaskRemotePath attribute contains a variable name. "False" specifies that the TaskRemotePath attribute does not contain a variable name.
TaskRemotePath	A string value that specifies the path in the remote location or, if the TaskIsRemotePathVar attribute is equal to "True", a string value that specifies the name of the variable.
TaskOverwriteDest	An enumeration value specifies whether the FTP operation can overwrite objects at the destination. "True" specifies that the task can overwrite objects at the destination. "False" specifies that the task MUST NOT overwrite objects at the destination.
TaskTransferAscii	An enumeration value specifies whether file transfer is performed in ASCII mode. "True" specifies that file transfer is performed in ASCII mode. "False" specifies that file transfer is not performed in ASCII mode.

2.7.1.13.1 FtpDataTaskOperationTypeEnum

The **FtpDataTaskOperationTypeEnum** type contains the enumeration values for specifying what FTP operation is performed.

The following is the XSD for the **FtpDataTaskOperationTypeEnum** type.

```
<xs:simpleType name="FtpDataTaskOperationTypeEnum">
  <xs:restriction base="xs:string">
    <xs:enumeration value="DeleteLocal"/>
    <xs:enumeration value="DeleteRemote"/>
    <xs:enumeration value="MakeDirLocal"/>
    <xs:enumeration value="MakeDirRemote"/>
    <xs:enumeration value="Receive"/>
    <xs:enumeration value="RemoveDirLocal"/>
    <xs:enumeration value="RemoveDirRemote"/>
    <xs:enumeration value="Send"/>
  </xs:restriction>
</xs:simpleType>
```

```

    </xs:restriction>
  </xs:simpleType>

```

The following table specifies the enumeration values for the **FtpDataTaskOperationTypeEnum** type.

Enumeration value	Description
DeleteLocal	Specifies that the FTP operation deletes a local file.
DeleteRemote	Specifies that the FTP operation deletes a remote file.
MakeDirLocal	Specifies that the FTP operation creates a local directory.
MakeDirRemote	Specifies that the FTP operation creates a remote directory.
Receive	Specifies that the FTP operation receives a file or directory.
RemoveDirLocal	Specifies that the FTP operation removes a local directory.
RemoveDirRemote	Specifies that the FTP operation removes a remote directory.
Send	Specifies that the FTP operation sends a file or directory.

2.7.1.14 MessageQueueTaskData Element

The **MessageQueueTaskData** element is used to specify parameters, properties, and settings that are specific to the execution of a Message Queue Task. The **MessageQueueTaskData** element resides in the [MessageQueueTask](#) namespace. The [ExecutableObjectType](#) type refers to the **MessageQueueTaskData** element within an XSD **choice** element, using the XSD **ref** attribute, in the following XSD fragment.

```

<xs:element ref="MessageQueueTask:MessageQueueTaskData"/>

```

2.7.1.14.1 MessageQueueTask Namespace

The **MessageQueueTask** namespace specifies the elements and types that are used by the Message Queue Task.

The following is the XSD declaration for the **MessageQueueTask** namespace.

```

xmlns:MessageQueueTask="www.microsoft.com/sqlserver/dts/tasks/messagequeuetask"

```

2.7.1.14.1.1 MessageQueueTaskData Element

The following is the XSD for the element declaration for the **MessageQueueTaskData** element in the [MessageQueueTask](#) namespace.

```

<xs:element name="MessageQueueTaskData"

```

```
type="MessageQueueTask:MessageQueueTaskType"/>
```

2.7.1.14.1.1.1 MessageQueueTaskType

The **MessageQueueTaskType** complex type holds parameters, properties, and settings for the Message Queue Task.

The following is the XSD for the **MessageQueueTaskType** complex type.

```
<xs:complexType name="MessageQueueTaskType">
  <xs:sequence>
  </xs:sequence>
  <xs:attribute name="CurrentPackageID" type="DTS:uuid" use="optional"
    default=""/>
  <xs:attribute name="TaskDescription" type="xs:string" use="optional"
    default=""/>
  <xs:attribute name="DataFileOverWritable" use="optional"
    default="False">
    <xs:simpleType>
      <xs:restriction base="xs:string">
        <xs:enumeration value="False"/>
        <xs:enumeration value="True"/>
      </xs:restriction>
    </xs:simpleType>
  </xs:attribute>
  <xs:attribute name="DTSMMessageLineageID" type="xs:string" use="optional"
    default=""/>
  <xs:attribute name="DTSMMessagePackageID" type="xs:string" use="optional"
    default=""/>
  <xs:attribute name="DTSMMessageVersionID" type="xs:string" use="optional"
    default=""/>
  <xs:attribute name="ErrorIfMessageTimeOut" use="optional"
    default="False">
    <xs:simpleType>
      <xs:restriction base="xs:string">
        <xs:enumeration value="False"/>
        <xs:enumeration value="True"/>
      </xs:restriction>
    </xs:simpleType>
  </xs:attribute>
  <xs:attribute name="QueuePath" type="xs:string"/>
  <xs:attribute name="ReceiveMessageTimeOut" type="xs:int" use="optional"
    default="0"/>
  <xs:attribute name="ReceiveMessageType"
    type="MessageQueueTask:MSMQMessageTypeEnum"
    use="optional" default="DTSMQMessageType_String"/>
  <xs:attribute name="RemoveFromQueue" use="optional" default="False">
    <xs:simpleType>
      <xs:restriction base="xs:string">
        <xs:enumeration value="False"/>
        <xs:enumeration value="True"/>
      </xs:restriction>
    </xs:simpleType>
  </xs:attribute>
  <xs:attribute name="SaveDataFileName" type="xs:string" use="optional"
    default=""/>
```

```

<xs:attribute name="StringCompareType"
  type="MessageQueueTask:MSMQStringCompareTypeEnum"
  use="optional" default="DTSMQStringMessageCompare_None"/>
<xs:attribute name="StringCompareValue" type="xs:string" use="optional"
  default=""/>
<xs:attribute name="StringMessageToVariableName" type="xs:string"
  use="optional" default=""/>
<xs:attribute name="ReceiveVariableMessage" type="xs:string"
  use="optional" default=""/>
<xs:attribute name="TaskType"
  type="MessageQueueTask:MSMQTaskTypeEnum"
  use="optional" default="DTSMQType_Sender"/>
<xs:attribute name="UseEncryption" use="optional" default="False">
  <xs:simpleType>
    <xs:restriction base="xs:string">
      <xs:enumeration value="False"/>
      <xs:enumeration value="True"/>
    </xs:restriction>
  </xs:simpleType>
</xs:attribute>
<xs:attribute name="EncryptionAlgorithm"
  type="MessageQueueTask:MSMQEncryptionAlgorithmEnum"
  use="optional" default="Rc2"/>
<xs:attribute name="Use2000Format" use="optional" default="False">
  <xs:simpleType>
    <xs:restriction base="xs:string">
      <xs:enumeration value="False"/>
      <xs:enumeration value="True"/>
    </xs:restriction>
  </xs:simpleType>
</xs:attribute>
<xs:attribute name="DataFileName" type="xs:string" use="optional"
  default=""/>
<xs:attribute name="StringMessage" type="xs:string" use="optional"
  default=""/>
<xs:attribute name="VariableMessage" type="xs:string" use="optional"
  default=""/>
<xs:attribute name="MessageType"
  type="MessageQueueTask:MSMQMessageTypeEnum"
  use="optional" default="DTSMQMessageType_String"/>
</xs:complexType>

```

The **MessageQueueTaskType** complex type MUST NOT contain elements.

The following table specifies additional information for the attributes of the **MessageQueueTaskType** complex type.

Attribute	Description
CurrentPackageID	A UUID value that specifies the DTSID attribute of the currently executing package.
TaskDescription	A string value that specifies a description for the task.
DataFileOverWritable	An enumeration value that specifies whether the message can overwrite an existing file. This enumeration value applies only if the MessageType attribute is equal to "DTSMQMessageType_DataFile".

Attribute	Description
	<p>"True" specifies that the task can overwrite a file.</p> <p>"False" specifies that the task MUST NOT overwrite a file.</p>
DTSMessageLineageID	A string value. <97>
DTSMessagePackageID	A UUID value that specifies the DTSID property of the package that is the source of the message.
DTSMessageVersionID	A string value that specifies the version of the message.
ErrorIfMessageTimeOut	<p>An enumeration value that specifies whether the task fails when the message times out.</p> <p>"True" specifies that the task MUST fail when the message times out.</p> <p>"False" specifies that the task does not necessarily fail when the message times out.</p>
QueuePath	A string value that specifies the ObjectName property of a connection manager for this message queue.
ReceiveMessageTimeOut	An integer value that specifies the number of seconds before a received message times out.
ReceiveMessageType	An enumeration value that specifies the type of the received message.
RemoveFromQueue	<p>An enumeration value that specifies whether to remove the message from the queue.</p> <p>"True" specifies that the message MUST be removed from the queue.</p> <p>"False" specifies that the message MUST NOT be removed from the queue.</p>
SaveDataFileName	A string value that specifies the name of the file to which an incoming message is saved.
StringCompareType	An enumeration value that specifies the string comparison method. This enumeration value is used only when the TaskType attribute is set to value "DTSMQType_Receiver".
StringCompareValue	A string value that specifies a string to which a string message is compared when the TaskType attribute is set to "DTSMQType_Receiver".
StringMessageToVariableName	A string value that specifies the name of the variable to which the message contents are saved.
ReceiveVariableMessage	A string value that specifies the name of the variable where a received message is saved.
TaskType	An enumeration value that specifies whether the task is sending a message or receiving a message.
UseEncryption	<p>An enumeration value that specifies whether to encrypt the messages.</p> <p>"True" specifies that the message MUST be encrypted.</p> <p>"False" specifies that the message MUST NOT be encrypted.</p>

Attribute	Description
EncryptionAlgorithm	An enumeration value that specifies the encryption algorithm to use.
Use2000Format	An enumeration value that specifies whether the message is formatted in a specific format. 98
DataFileName	A string value that specifies the name of the file that is used if the message type uses a file.
StringMessage	A string value that contains the message text. This string value is used only if the MessageType attribute is set to the "DTSMQMessageType_String" value.
VariableMessage	A string value that contains the message text. This string value is used only if the MessageType attribute is set to the "DTSMQMessageType_Variables" value.
MessageType	An enumeration value that specifies the type of message that is sent. This enumeration value is used only when the TaskType attribute is set to "DTSMQType_Sender".

2.7.1.14.1.1.1.1 MSMQStringCompareTypeEnum

The **MSMQStringCompareTypeEnum** type contains the enumeration values for the **StringCompareType** attribute.

The following is the XSD of the **MSMQStringCompareTypeEnum** type.

```
<xs:simpleType name="MSMQStringCompareTypeEnum">
  <xs:restriction base="xs:string">
    <xs:enumeration value="DTSMQStringMessageCompare_Contains"/>
    <xs:enumeration value="DTSMQStringMessageCompare_Exact"/>
    <xs:enumeration value="DTSMQStringMessageCompare_IgnoreCase"/>
    <xs:enumeration value="DTSMQStringMessageCompare_None"/>
  </xs:restriction>
</xs:simpleType>
```

The following table specifies the enumeration values for the **MSMQStringCompareTypeEnum** type.

Enumeration value	Description
DTSMQStringMessageCompare_Contains	Specifies that the comparison operation is successful if the received message contains the comparison string.
DTSMQStringMessageCompare_Exact	Specifies that the comparison operation is successful if the received message exactly matches the comparison string.
DTSMQStringMessageCompare_IgnoreCase	Specifies that the comparison operation is successful if the received message matches the comparison string, ignoring the case of letters.
DTSMQStringMessageCompare_None	Specifies that no comparison operation is performed.

2.7.1.14.1.1.1.2 MSMQTaskTypeEnum

The **MSMQTaskTypeEnum** type contains the enumeration values for the **TaskType** attribute.

The following is the XSD of the **MSMQTaskTypeEnum** type.

```
<xs:simpleType name="MSMQTaskTypeEnum">
  <xs:restriction base="xs:string">
    <xs:enumeration value="DTSMQType_Receiver"/>
    <xs:enumeration value="DTSMQType_Sender"/>
  </xs:restriction>
</xs:simpleType>
```

The following table specifies the enumeration values for the **MSMQTaskTypeEnum** type.

Enumeration value	Description
DTSMQType_Receiver	Specifies that the task receives messages.
DTSMQType_Sender	Specifies that the task sends messages.

2.7.1.14.1.1.1.3 MSMQMessageTypeEnum

The **MSMQMessageTypeEnum** type contains the enumeration values for the **MessageType** attribute.

The following is the XSD of the **MSMQMessageTypeEnum** type.

```
<xs:simpleType name="MSMQMessageTypeEnum">
  <xs:restriction base="xs:string">
    <xs:enumeration value="DTSMQMessageType_StringMessageToVariable"/>
    <xs:enumeration value="DTSMQMessageType_DataFile"/>
    <xs:enumeration value="DTSMQMessageType_String"/>
    <xs:enumeration value="DTSMQMessageType_Variables"/>
  </xs:restriction>
</xs:simpleType>
```

The following table specifies the enumeration values for the **MSMQMessageTypeEnum** type.

Enumeration value	Description
DTSMQMessageType_StringMessageToVariable	Specifies that the message source is text and that the message destination is a variable. This value is valid only if the TaskType attribute is equal to "DTSMQType_Sender".
DTSMQMessageType_DataFile	Specifies that the message source is a data file.
DTSMQMessageType_String	Specifies that the message source is a string.
DTSMQMessageType_Variables	Specifies that the message source is a variable and that the message destination is also a variable.

2.7.1.14.1.1.1.4 MSMQEncryptionAlgorithmEnum

The **MSMQEncryptionAlgorithmEnum** type contains the enumeration values for the **EncryptionAlgorithm** attribute.

The following is the XSD of the **MSMQEncryptionAlgorithmEnum** type.

```
<xs:simpleType name="MSMQEncryptionAlgorithmEnum">
  <xs:restriction base="xs:string">
    <xs:enumeration value="Rc2"/>
    <xs:enumeration value="Rc4"/>
  </xs:restriction>
</xs:simpleType>
```

The following table specifies the enumeration values for the **MSMQEncryptionAlgorithmEnum** type.

Enumeration value	Description
Rc2	Specifies that the RC2 encryption algorithm [RFC2268] is used.
Rc4	Specifies that the RC4 encryption algorithm [SCAN-RC4] is used.

2.7.1.15 ScriptProjectObjectType

The **ScriptProjectObjectType** complex type is used to specify parameters, properties, and settings that are specific to the Script Task.

The following is the XSD of the **ScriptProjectObjectType** complex type.

```
<xs:complexType name="ScriptProjectObjectType">
  <xs:sequence>
    <xs:element name="ProjectItem"
      type="DTS:ScriptProjectProjectItemType"
      minOccurs="0" maxOccurs="unbounded"
      form="unqualified"/>
    <xs:element name="BinaryItem"
      type="DTS:ScriptProjectBinaryItemType"
      minOccurs="0" form="unqualified"/>
    <xs:element name="Breakpoint"
      type="DTS:ScriptProjectBreakpointType"
      minOccurs="0" maxOccurs="unbounded"
      form="unqualified"/>
  </xs:sequence>
  <xs:attribute name="Name" type="xs:string" form="unqualified"/>
  <xs:attribute name="VSTAMajorVersion" type="xs:int"
    form="unqualified"/>
  <xs:attribute name="VSTAMinorVersion" type="xs:int"
    form="unqualified"/>
  <xs:attribute name="Language" type="DTS:ScriptProjectLanguageEnum"
    form="unqualified"/>
  <xs:attribute name="EntryPoint" type="xs:string"
    form="unqualified"/>
  <xs:attribute name="ReadOnlyVariables" type="xs:string"
    form="unqualified"/>
</xs:complexType>
```

```

        form="unqualified"/>
        <xs:attribute name="ReadWriteVariables" type="xs:string"
        form="unqualified"/>
    </xs:complexType>

```

The following table provides additional information about the elements, types, and constraints in the **ScriptProjectObjectType** complex type.

Element	Additional constraints	Type definition	Description
ProjectItem	None	ScriptProjectProjectItemType	A string value that specifies the source code for a single item of a development environment project.
BinaryItem	None	ScriptProjectBinaryItemType	A base64 binary value that specifies the compiled binary from the development environment of the script project.
Breakpoint	None	ScriptProjectBreakpointType	A complex value that specifies a breakpoint in the code.

The following table specifies the attributes of the **ScriptProjectObjectType** complex type.

Attribute	Description
Name	A string value that specifies the name of the script project task.
VSTAMajorVersion	An integer value that specifies the major version number. <99>
VSTAMinorVersion	An integer value that specifies the minor version number. <100>
Language	An enumeration value that specifies the language for the script project.
EntryPoint	A string value that specifies the name of the entry point routine in the code for the script project.
ReadOnlyVariables	A string value that specifies read-only variables in the package file that are available to the code in the script project.
ReadWriteVariables	A string value that specifies the read-write variables in the package file that are available to the code in the script project.

2.7.1.15.1 ScriptProjectProjectItemType

The **ScriptProjectProjectItemType** complex type is used to specify the source code for the Script Component that is executed.

The following is the XSD of the **ScriptProjectProjectItemType** complex type.

```

<xs:complexType name="ScriptProjectProjectItemType">
  <xs:simpleContent>
    <xs:extension base="xs:string">
      <xs:attribute name="Name" type="xs:string"

```

```

        form="unqualified"/>
    <xs:attribute name="Encoding" type="xs:string"
        form="unqualified"/
    </xs:extension>
</xs:simpleContent>
</xs:complexType>

```

The value of element of the **ScriptProjectProjectItemType** is a string that specifies one source code item of the source code for the Script Component that is executed.

The following table specifies additional information for the attributes of the **ScriptProjectProjectItemType** complex type.

Attribute	Description
Name	A string value that specifies the name of the source file in the development environment in which the source code was developed.
Encoding	A string value that specifies the name of the encoding that is used to encode the source code for the Script Component that is executed.

2.7.1.15.2 ScriptProjectBinaryItemType

The **ScriptProjectBinaryItemType** complex type contains a representation of the binary of the compiled code for the Script Component.

The following is the XSD of the **ScriptProjectBinaryItemType** complex type.

```

<xs:complexType name="ScriptProjectBinaryItemType">
  <xs:simpleContent>
    <xs:extension base="xs:base64Binary">
      <xs:attribute name="Name" type="xs:string"
        form="unqualified"/>
    </xs:extension>
  </xs:simpleContent>
</xs:complexType>

```

The value of element of the **ScriptProjectBinaryItemType** complex type is a base64 binary representation that specifies the executable code for the Script Component.

The following table specifies additional information for the attributes of the **ScriptProjectBinaryItemType** complex type.

Attribute	Description
Name	A string value that specifies the name of the binary file in the development environment in which the source code was developed.

2.7.1.15.3 ScriptProjectBreakpointType

The **ScriptProjectBreakpointType** complex type contains a representation of the breakpoints that are set in the development environment for the Script Component.

The following is the XSD of the **ScriptProjectBreakpointType** complex type.

```
<xs:complexType name="ScriptProjectBreakpointType">
  <xs:sequence/>
  <xs:attribute name="Name" type="xs:string" form="unqualified"/>
  <xs:attribute name="Enabled" type="xs:string"
    form="unqualified"/>
  <xs:attribute name="Function" type="xs:string"
    form="unqualified"/>
  <xs:attribute name="File" type="xs:string" form="unqualified"/>
  <xs:attribute name="Line" type="xs:int" form="unqualified"/>
  <xs:attribute name="Column" type="xs:int" form="unqualified"/>
  <xs:attribute name="Condition" type="xs:string"
    form="unqualified"/>
  <xs:attribute name="ConditionType"
    type="DTS:ScriptProjectConditionTypeEnum"
    form="unqualified"/>
  <xs:attribute name="Language" type="xs:string"
    form="unqualified"/>
  <xs:attribute name="HitCount" type="xs:int" form="unqualified"/>
  <xs:attribute name="HitCountType" form="unqualified"
    type="DTS:ScriptProjectHitCountTypeEnum"/>
</xs:complexType>
```

The following table specifies additional information for the attributes of the **ScriptProjectBinaryItemType** complex type.

Attribute	Description
Name	A string value that specifies the name of the breakpoint.
Enabled	An enumeration value that specifies whether the breakpoint is enabled. "True" specifies that the breakpoint is enabled. "False" specifies that the breakpoint is not enabled.
Function	A string value that specifies the name of the function in which the breakpoint is set.
File	A string value that specifies the name of the file in which the breakpoint is set.
Line	An integer value that specifies the line number at which the breakpoint is set.
Column	An integer value that specifies the character column at which the breakpoint is set.
Condition	A string value that specifies a condition that can be evaluated as a Boolean to determine whether the breakpoint is fired. Whether the breakpoint is fired depends on this Condition value and on the values of the following attributes: ConditionType HitCount HitType
ConditionType	An enumeration value that specifies when the evaluation of the string in the Condition attribute causes a breakpoint to be fired.
Language	A string value that specifies the language of the Script Component. <101>

Attribute	Description
HitCount	An integer value that specifies a criteria for a hit count. This value, along with the value of the HitCountType attribute, is used to determine whether a break point is fired.
HitCountType	An enumeration value that specifies the type of hit count condition that causes the breakpoint to be fired.

2.7.1.15.4 ScriptProjectLanguageEnum

The **ScriptProjectLanguageEnum** type contains the enumeration values for the **Language** attribute.

The following is the XSD of the **ScriptProjectLanguageEnum** type.

```
<xs:simpleType name="ScriptProjectLanguageEnum">
  <xs:restriction base="xs:string">
    <xs:enumeration value="CSharp"/>
    <xs:enumeration value="VisualBasic"/>
  </xs:restriction>
</xs:simpleType>
```

The following table specifies the enumeration values for the **ScriptProjectLanguageEnum** type.

Enumeration value	Description
CSharp	Specifies that the C# language [MSDN-C#LS] is used.
VisualBasic	Specifies that the Visual Basic language [MSDN-VBLR] is used.

2.7.1.15.5 ScriptProjectHitCountTypeEnum

The **ScriptProjectHitCountTypeEnum** type contains the enumeration values for the **HitCountType** attribute.

The following is the XSD of the **ScriptProjectHitCountTypeEnum** type.

```
<xs:simpleType name="ScriptProjectHitCountTypeEnum">
  <xs:restriction base="xs:int">
    <xs:minInclusive value="1"/>
    <xs:maxInclusive value="4"/>
  </xs:restriction>
</xs:simpleType>
```

The following table specifies the enumeration values for the **ScriptProjectLanguageEnum** type.

Enumeration value	Description
1	Specifies that there is no hit count.
2	Specifies that the hit count is equal to the specified condition.

Enumeration value	Description
3	Specifies that the hit count is greater than or equal to the specified condition.
4	Specifies that there are multiple hit count conditions.

2.7.1.15.6 ScriptProjectConditionTypeEnum

The **ScriptProjectConditionTypeEnum** type contains the enumeration values for the **ConditionType** attribute.

The following is the XSD of the **ScriptProjectConditionTypeEnum** type.

```
<xs:simpleType name="ScriptProjectConditionTypeEnum">
  <xs:restriction base="xs:int">
    <xs:minInclusive value="1"/>
    <xs:maxInclusive value="2"/>
  </xs:restriction>
</xs:simpleType>
```

The following table specifies the enumeration values for the **ScriptProjectLanguageEnum** type.

Enumeration value	Description
1	Break when condition is true.
2	Break when condition is changed.

2.7.1.16 SendMailTaskData Element

The **SendMailTaskData** element is used to specify parameters, properties, and settings that are specific to the execution of a Send Mail Task. This element resides in the [SendMailTask](#) namespace. The [ExecutableObjectDataType](#) type refers to this element within an XSD **choice** element, using the XSD **ref** attribute, in the following XSD fragment.

```
<xs:element ref="SendMailTask:SendMailTaskData"/>
```

2.7.1.16.1 SendMailTask Namespace

The **SendMailTask** namespace specifies elements and types that are used by the Send Mail Task.

The following is the XSD declaration for the **SendMailTask** namespace.

```
xmlns:SendMailTask="www.microsoft.com/sqlserver/dts/tasks/sendmailtask"
```

2.7.1.16.1.1 SendMailTaskData Element

The following is the XSD for the element declaration for the **SendMailTaskData** element in the [SendMailTask](#) namespace.

```
<xs:element name="SendMailTaskData"
  type="SendMailTask:SendMailTaskType"/>
```

2.7.1.16.1.1.1 SendMailTaskType

The **SendMailTaskType** complex type holds parameters, properties, and settings for the Send Mail Task.

The following is the XSD for the **SendMailTaskType** complex type.

```
<xs:complexType name="SendMailTaskType">
  <xs:sequence>
    <xs:element name="Attachments" minOccurs="0"
      type="SendMailTask:AttachmentsElementType"/>
  </xs:sequence>
  <xs:attribute name="SMTPServer" type="xs:string" use="optional"
    default=""/>
  <xs:attribute name="From" type="xs:string" use="optional" default=""/>
  <xs:attribute name="To" type="xs:string" use="optional" default=""/>
  <xs:attribute name="CC" type="xs:string" use="optional" default=""/>
  <xs:attribute name="BCC" type="xs:string" use="optional" default=""/>
  <xs:attribute name="Subject" type="xs:string" use="optional"
    default=""/>
  <xs:attribute name="Priority"
    type="SendMailTask:SendMailPriorityEnum"
    use="optional" default="Normal"/>
  <xs:attribute name="MessageSourceType"
    type="DTS:SourceTypeEnum"/>
  <xs:attribute name="MessageSource" type="xs:string"
    use="optional" default="DirectInput"/>
</xs:complexType>
```

The following table provides additional information about the elements, types, and constraints for the **SendMailTaskType** complex type.

Element	Additional constraints	Type definition	Description
Attachments	None.	AttachmentsElementType	Contains information about the files to be attached to the message.

The following table specifies additional information for the attributes of the **SendMailTaskType** complex type.

Attribute	Description
SMTPServer	A string value that specifies a reference to a connection manager by its DTSID property value or by its ObjectName property value.
From	A string value that specifies the From field of the mail message.
To	A string value that specifies the To field of the mail message.

Attribute	Description
CC	A string value that specifies the Cc field of the mail message.
BCC	A string value that specifies the Bcc field of the mail message.
Subject	A string value that specifies the Subject field of the mail message.
Priority	An enumeration value that specifies the priority of the mail message.
MessageSourceType	An enumeration value that specifies the source type of the mail message.
MessageSource	A string value that specifies the content of the mail message. This value is used only if the MessageSourceType attribute is set to the value "DirectInput".

2.7.1.16.1.1.1.1 AttachmentsElementType

The **AttachmentsElementType** complex type is used to specify attachments to mail messages that are sent with the Send Mail Task.

The following is the XSD for the **AttachmentsElementType** complex type.

```
<xs:complexType name="AttachmentsElementType">
  <xs:sequence/>
  <xs:attribute name="FileName" type="xs:string"/>
</xs:complexType>
```

The following table specifies additional information for the attributes of the **AttachmentsElementType** complex type.

Attribute	Description
FileName	A string value that specifies the names of the files that are attached to the mail message that is sent by the Send Mail Task. If more than one file is attached, the file names MUST be separated by a vertical bar () character.

2.7.1.16.1.1.1.2 SendMailPriorityEnum

The **SendMailPriorityEnum** type contains the enumeration values for the **Priority** attribute.

The following is the XSD of the **SendMailPriorityEnum** type.

```
<xs:simpleType name="SendMailPriorityEnum">
  <xs:restriction base="xs:string">
    <xs:enumeration value="High"/>
    <xs:enumeration value="Low"/>
    <xs:enumeration value="Normal"/>
  </xs:restriction>
</xs:simpleType>
```

The following table specifies the enumeration values for the **SendMailPriorityEnum** type.

Enumeration value	Description
High	Specifies that the mail message is marked as high priority.
Low	Specifies that the mail message is marked as low priority.
Normal	Specifies that the mail message is marked as normal priority.

2.7.1.17 TransferDatabaseTaskDataObjectDataType

The **TransferDatabaseTaskDataObjectDataType** complex type is used to specify parameters, properties, and settings that are specific to the Transfer Database Task.

The following is the XSD for the **TransferDatabaseTaskDataObjectDataType** complex type.

```
<xs:complexType name="TransferDatabasesTaskDataObjectDataType">
  <xs:sequence/>
  <xs:attribute name="SrcConn" type="xs:string" use="optional" default=""
    form="unqualified"/>
  <xs:attribute name="DestConn" type="xs:string" use="optional"
    default="" form="unqualified"/>
  <xs:attribute name="Action" type="DTS:TransferDatabaseTaskActionEnum"
    use="optional" default="0" form="unqualified"/>
  <xs:attribute name="Method" type="DTS:TransferDatabaseTaskMethodEnum"
    use="optional" default="0" form="unqualified"/>
  <xs:attribute name="SrcDBName" type="xs:string" use="optional"
    default="" form="unqualified"/>
  <xs:attribute name="ReattachSrcDB" type="xs:boolean"
    use="optional" default="false" form="unqualified"/>
  <xs:attribute name="SrcDBFiles" type="xs:string"
    use="optional" default="" form="unqualified"/>
  <xs:attribute name="DestDBName" type="xs:string"
    use="optional" default="" form="unqualified"/>
  <xs:attribute name="DestDBFiles" type="xs:string"
    use="optional" default="" form="unqualified"/>
  <xs:attribute name="DestOverwrite" type="xs:boolean"
    use="optional" default="false" form="unqualified"/>
</xs:complexType>
```

The **TransferDatabaseTaskDataObjectDataType** complex type MUST NOT contain any elements or values.

The following table specifies the attributes of the **TransferDatabaseTaskDataObjectDataType** complex type.

Attribute	Description
SrcConn	A string value that specifies a reference to a connection manager by its DTSID property value or by its ObjectName property value.
DestConn	A string value that specifies a reference to a connection manager by its DTSID property value or by its ObjectName property value.
Action	An enumeration value that specifies which transfer action to perform.

Attribute	Description
Method	An enumeration value that specifies the method to use when performing the database transfer.
SrcDBName	A string value that specifies the name of the source database.
ReattachSrcDB	A Boolean value that specifies whether to attempt to reattach the source database if a failure occurs. TRUE specifies that there MUST be an attempt to reattach the source database if a failure occurs. FALSE specifies that there MUST NOT be an attempt to reattach the source database if a failure occurs.
SrcDBFiles	A string value that specifies the name and location of the files at the source database. The string value is a comma-delimited list.
DestDBName	A string value that specifies the name of the destination database.
DestDBFiles	A string value that specifies the name and location of the files at the destination database. The string value is a comma-delimited list.
DestOverwrite	A Boolean value that specifies whether to overwrite a database at the destination if a database of the same name exists at the destination. TRUE specifies that a database of the same name at the destination MUST be overwritten. FALSE specifies that a database of the same name at the destination MUST NOT be overwritten.

2.7.1.17.1 TransferDatabaseTaskActionEnum

The **TransferDatabaseTaskActionEnum** type contains the enumeration values for the **Action** attribute.

The following is the XSD of the **TransferDatabaseTaskActionEnum** type.

```
<xs:simpleType name="TransferDatabaseTaskActionEnum">
  <xs:restriction base="xs:int">
    <xs:minInclusive value="0"/>
    <xs:maxInclusive value="1"/>
  </xs:restriction>
</xs:simpleType>
```

The following table specifies the enumeration values for the **TransferDatabaseTaskActionEnum** type.

Enumeration value	Description
0	The database MUST be transferred by using a copy operation.
1	The database MUST be transferred by using a move operation.

2.7.1.17.2 TransferDatabaseTaskMethodEnumType

The **TransferDatabaseTaskMethodEnum** type contains the enumeration values for the **Method** attribute.

The following is the XSD of the **TransferDatabaseTaskActionEnum** type.

```
<xs:simpleType name="TransferDatabaseTaskMethodEnum">
  <xs:restriction base="xs:int">
    <xs:minInclusive value="0"/>
    <xs:maxInclusive value="1"/>
  </xs:restriction>
</xs:simpleType>
```

The following table specifies the enumeration values for the **TransferDatabaseTaskMethodEnum** type.

Enumeration value	Description
0	The database MUST be transferred when the database is offline.
1	The database MUST be transferred when the database is online.

2.7.1.18 TransferErrorMessagesTaskDataObjectDataType

The **TransferErrorMessagesTaskDataObjectDataType** complex type is used to specify parameters, properties, and settings that are specific to the Transfer Error Messages Task.

The following is the XSD for the **TransferErrorMessagesTaskDataObjectDataType** complex type.

```
<xs:complexType name="TransferErrorMessagesTaskDataObjectDataType">
  <xs:sequence/>
  <xs:attribute name="TransferAllErrorMessages" type="xs:boolean"
    use="optional" default="false" form="unqualified"/>
  <xs:attribute name="ErrorMessagesList" type="xs:string"
    use="optional" default="" form="unqualified"/>
  <xs:attribute name="ErrorMessageLanguagesList" type="xs:string"
    use="optional" default="" form="unqualified"/>
  <xs:attribute name="IfObjectExists"
    type="DTS:IfObjectExistsEnum"
    use="optional" default="FailTask" form="unqualified"/>
  <xs:attribute name="SourceConnection" type="xs:string"
    use="optional" default="" form="unqualified"/>
  <xs:attribute name="DestinationConnection" type="xs:string"
    use="optional" default="" form="unqualified"/>
</xs:complexType>
```

The **TransferErrorMessagesTaskDataObjectDataType** complex type MUST NOT contain any elements or values.

The following table specifies the attributes of the **TransferErrorMessagesTaskDataObjectDataType** complex type.

Attribute	Description
TransferAllErrorMessages	A Boolean value that specifies whether to transfer all user-defined error messages or only the specified user-defined error messages. TRUE specifies that all user-defined error messages MUST be transferred. FALSE specifies that only the specified user-defined messages are transferred.
ErrorMessageList	A string value that specifies a list of the error messages that are transferred.
ErrorMessageLanguagesList	A string value that specifies a list of languages for which the error messages are transferred.
IfObjectExists	An enumeration value that specifies what action is taken if an error message with the same name already exists at the destination.
SourceConnection	A string value that specifies a reference to a connection manager by its DTSID property value or by its ObjectName property value.
DestinationConnection	A string value that specifies a reference to a connection manager by its DTSID property value or by its ObjectName property value.

2.7.1.19 TransferJobsTaskDataObjectDataType

The **TransferJobsTaskDataObjectDataType** complex type is used to specify parameters, properties, and settings that are specific to the Transfer Jobs Task.

The following is the XSD for the **TransferJobsTaskDataObjectDataType** complex type.

```
<xs:complexType name="TransferJobsTaskDataObjectDataType">
  <xs:sequence/>
  <xs:attribute name="TransferAllJobs" type="xs:boolean"
    use="optional" default="false" form="unqualified"/>
  <xs:attribute name="JobsList" type="xs:string"
    use="optional" default="" form="unqualified"/>
  <xs:attribute name="IfObjectExists" type="DTS:IfObjectExistsEnum"
    use="optional" default="FailTask" form="unqualified"/>
  <xs:attribute name="EnableJobsAtDestination" type="xs:boolean"
    use="optional" default="false" form="unqualified"/>
  <xs:attribute name="SourceConnection" type="xs:string"
    use="optional" default="" form="unqualified"/>
  <xs:attribute name="DestinationConnection" type="xs:string"
    use="optional" default="" form="unqualified"/>
</xs:complexType>
```

The **TransferJobsTaskDataObjectDataType** complex type MUST NOT contain any elements or values.

The following table specifies the attributes of the **TransferJobsTaskDataObjectDataType** complex type.

Attribute	Description
TransferAllJobs	A Boolean value that specifies whether to transfer all jobs or only the specified jobs. TRUE specifies that all jobs MUST be transferred. FALSE specifies that only the specified jobs are transferred.
JobsList	A string value that specifies a list of jobs that are transferred.
IfObjectExists	An enumeration value that specifies what action is taken if a job of the same name already exists at the destination.
EnableJobsAtDestination	A Boolean value that specifies whether jobs created at the destination should be enabled. TRUE specifies that jobs that are created at the destination MUST be enabled. FALSE specifies that jobs that are created at the destination MUST NOT be enabled.
SourceConnection	A string value that specifies a reference to a connection manager by its DTSID property value or by its ObjectName property value.
DestinationConnection	A string value that specifies a reference to a connection manager by its DTSID property value or by its ObjectName property value.

2.7.1.20 TransferLoginsTaskDataObjectDataType

The **TransferLoginsTaskDataObjectDataType** complex type is used to specify parameters, properties, and settings that are specific to the Transfer Logins Task.

The following is the XSD for the **TransferLoginsTaskDataObjectDataType** complex type.

```
<xs:complexType name="TransferLoginsTaskDataObjectDataType">
  <xs:sequence/>
  <xs:attribute name="LoginsToTransfer"
    type="DTS:TransferLoginsTaskLoginsToTransferEnum"
    use="optional" default="SelectedLogins"
    form="unqualified"/>
  <xs:attribute name="CopySids" type="xs:boolean" form="unqualified"
    use="optional" default="false"/>
  <xs:attribute name="LoginList" type="xs:string" form="unqualified"
    use="optional" default=""/>
  <xs:attribute name="IfObjectExists" type="DTS:IfObjectExistsEnum"
    use="optional" default="FailTask" form="unqualified"/>
  <xs:attribute name="SourceConnection" type="xs:string"
    use="optional" default="" form="unqualified"/>
  <xs:attribute name="DestinationConnection" type="xs:string"
    use="optional" default="" form="unqualified"/>
  <xs:attribute name="DatabasesList" type="xs:string"
    use="optional" default="" form="unqualified"/>
</xs:complexType>
```

The **TransferLoginsTaskDataObjectDataType** complex type MUST NOT contain any elements or values.

The following table specifies the attributes of the **TransferLoginsTaskDataObjectType** complex type.

Attribute	Description
LoginsToTransfer	An enumeration value that specifies which logins MUST be transferred by the task.
CopySids	A Boolean value that specifies whether the security identifiers (SIDS) that are associated with logins are also transferred. TRUE specifies that the SIDS MUST be transferred with the logins. FALSE specifies that the SIDS MUST NOT be transferred with the logins.
LoginList	A string value that specifies the list of logins to be transferred.
IfObjectExists	An enumeration value that specifies what action is taken if a login of the same name already exists at the destination.
SourceConnection	A string value that specifies a reference to a connection manager by its DTSID property value or by its ObjectName property value.
DestinationConnection	A string value that specifies a reference to a connection manager by its DTSID property value or by its ObjectName property value.
DatabaseList	A string value that specifies the list of databases that exist on the source connection to transfer.

2.7.1.20.1 TransferLoginsTaskLoginsToTransferEnum

The **TransferLoginsTaskLoginsToTransferEnum** type contains the enumeration values for the **LoginsToTransfer** attribute.

The following is the XSD of the **TransferLoginsTaskLoginsToTransferEnum** type.

```
<xs:simpleType name="TransferLoginsTaskLoginsToTransferEnum">
  <xs:restriction base="xs:string">
    <xs:enumeration value="SelectedLogins"/>
    <xs:enumeration value="AllLoginsFrom SelectedDatabases"/>
    <xs:enumeration value="AllLogins"/>
  </xs:restriction>
</xs:simpleType>
```

The following table specifies the enumeration values for the **TransferLoginsTaskLoginsToTransferEnum** type.

Enumeration value	Description
SelectedLogins	Specifies that the selected logins are transferred.
AllLoginsFromSelectedDatabases	Specifies that all logins from the selected databases are transferred.
AllLogins	Specifies that all logins are transferred.

2.7.1.21 TransferStoredProceduresTaskDataObjectType

The **TransferStoredProceduresTaskDataObjectType** complex type is used to specify parameters, properties, and settings that are specific to the Transfer Stored Procedures Task.

The following is the XSD for the **TransferStoredProceduresTaskDataObjectType** complex type.

```
<xs:complexType name="TransferStoredProceduresTaskDataObjectType">
  <xs:sequence/>
  <xs:attribute name="TransferAllStoredProcedures"
    type="xs:boolean" use="optional" default="false"
    form="unqualified"/>
  <xs:attribute name="StoredProceduresList" type="xs:string"
    use="optional" default="" form="unqualified"/>
  <xs:attribute name="IfObjectExists" type="DTS:IfObjectExistsEnum"
    use="optional" default="FailTask" form="unqualified"/>
  <xs:attribute name="SourceConnection" type="xs:string"
    use="optional" default="" form="unqualified"/>
  <xs:attribute name="m_DestinationConnectionID"
    use="optional" default="" type="xs:string"
    form="unqualified"/>
</xs:complexType>
```

The **TransferStoredProceduresTaskDataObjectType** complex type MUST NOT contain any elements or values.

The following table specifies the attributes of the **TransferStoredProceduresTaskDataObjectType** complex type.

Attribute	Description
TransferAllStoredProcedures	A Boolean value that specifies whether to transfer all user-defined stored procedures in the master database or just the specified stored procedures. TRUE specifies that all user-defined stored procedures in the master database MUST be transferred. FALSE specifies that only the specified stored procedures in the database are transferred.
StoredProceduresList	A string value that specifies the list of stored procedures in the master database that are transferred.
IfObjectExists	An enumeration value that specifies what action is taken if a stored procedure of the same name already exists at the destination.
SourceConnection	A string value that specifies a reference to a connection manager by its DTSID property value or by its ObjectName property value.
m_DestinationConnectionID	A string value that specifies a reference to a connection manager by its DTSID property value or by its ObjectName property value.

2.7.1.22 TransferSqlServerObjectsTaskDataObjectDataType

The **TransferSqlServerObjectsTaskDataObjectDataType** complex type is used to specify parameters, properties, and settings that are specific to the Transfer SQL Server Objects Task.

The following is the XSD for the **TransferSqlServerObjectsTaskDataObjectDataType** complex type.

```
<xs:complexType name="TransferSqlServerObjectsTaskDataObjectDataType">
  <xs:sequence/>
  <xs:attribute name="SourceConnection" type="xs:string"
    use="optional" default="" form="unqualified"/>
  <xs:attribute name="DestinationConnection" type="xs:string"
    use="optional" default="" form="unqualified"/>
  <xs:attribute name="SourceDatabase" type="xs:string"
    use="optional" default="" form="unqualified"/>
  <xs:attribute name="DestinationDatabase" type="xs:string"
    use="optional" default="" form="unqualified"/>
  <xs:attribute name="CopyAllObjects" type="xs:boolean"
    use="optional" default="false" form="unqualified"/>
  <xs:attribute name="CopyAllRules" type="xs:boolean"
    use="optional" default="false" form="unqualified"/>
  <xs:attribute name="CopyAllTables" type="xs:boolean"
    use="optional" default="false" form="unqualified"/>
  <xs:attribute name="CopyAllViews" type="xs:boolean"
    use="optional" default="false" form="unqualified"/>
  <xs:attribute name="CopyAllStoredProcedures"
    type="xs:boolean" use="optional" default="false"
    form="unqualified"/>
  <xs:attribute name="CopyAllUserDefinedFunctions"
    type="xs:boolean" use="optional" default="false"
    form="unqualified"/>
  <xs:attribute name="CopyAllDefaults" type="xs:string"
    use="optional" default="false" form="unqualified"/>
  <xs:attribute name="CopyAllUserDefinedDataTypes"
    use="optional" default="false" type="xs:boolean"
    form="unqualified"/>
  <xs:attribute name="CopyAllPartitionFunctions" type="xs:boolean"
    use="optional" default="false" form="unqualified"/>
  <xs:attribute name="CopyAllPartitionSchemes" type="xs:boolean"
    use="optional" default="false" form="unqualified"/>
  <xs:attribute name="CopyAllSchemas" type="xs:boolean"
    use="optional" default="false" form="unqualified"/>
  <xs:attribute name="CopyAllSqlAssemblies" type="xs:boolean"
    use="optional" default="false" form="unqualified"/>
  <xs:attribute name="CopyAllUserDefinedAggregates"
    use="optional" default="false" type="xs:boolean"
    form="unqualified"/>
  <xs:attribute name="CopyAllUserDefinedTypes" type="xs:boolean"
    use="optional" default="false" form="unqualified"/>
  <xs:attribute name="CopyAllXmlSchemaCollections" type="xs:boolean"
    use="optional" default="false" form="unqualified"/>
  <xs:attribute name="LoginsList" type="xs:string"
    use="optional" default="" form="unqualified"/>
  <xs:attribute name="UsersList" type="xs:string"
    use="optional" default="" form="unqualified"/>
  <xs:attribute name="RulesList" type="xs:string"
    use="optional" default="" form="unqualified"/>

```

```

<xs:attribute name="TablesList" type="xs:string"
    use="optional" default="" form="unqualified"/>
<xs:attribute name="ViewsList" type="xs:string"
    use="optional" default="" form="unqualified"/>
<xs:attribute name="StoredProceduresList"
    type="xs:string" use="optional" default=""
    form="unqualified"/>
<xs:attribute name="UserDefinedFunctionsList"
    type="xs:string" use="optional" default=""
    form="unqualified"/>
<xs:attribute name="DefaultsList" type="xs:string"
    use="optional" default="" form="unqualified"/>
<xs:attribute name="UserDefinedDataTypesList"
    type="xs:string" use="optional" default=""
    form="unqualified"/>
<xs:attribute name="PartitionFunctionsList" type="xs:string"
    use="optional" default="" form="unqualified"/>
<xs:attribute name="PartitionSchemesList" type="xs:string"
    use="optional" default="" form="unqualified"/>
<xs:attribute name="SchemasList" type="xs:string"
    use="optional" default="" form="unqualified"/>
<xs:attribute name="SqlAssembliesList" type="xs:string"
    use="optional" default="" form="unqualified"/>
<xs:attribute name="UserDefinedAggregatesList"
    type="xs:string" use="optional" default=""
    form="unqualified"/>
<xs:attribute name="UserDefinedTypesList" type="xs:string"
    use="optional" default="" form="unqualified"/>
<xs:attribute name="XmlSchemaCollectionsList" type="xs:string"
    use="optional" default="" form="unqualified"/>
<xs:attribute name="DropObjectsFirst" type="xs:boolean"
    use="optional" default="false" form="unqualified"/>
<xs:attribute name="IncludeDependentObjects"
    type="xs:boolean" use="optional" default="false"
    form="unqualified"/>
<xs:attribute name="IncludeExtendedProperties" type="xs:boolean"
    use="optional" default="false" form="unqualified"/>
<xs:attribute name="CopyData" type="xs:boolean"
    use="optional" default="false" form="unqualified"/>
<xs:attribute name="ExistingData"
    type="DTS:TransferSqlServerObjectsTaskExistingDataEnum"
    use="optional" default="Replace" form="unqualified"/>
<xs:attribute name="CopySchema" type="xs:boolean"
    use="optional" default="true" form="unqualified"/>
<xs:attribute name="UseCollation" type="xs:boolean"
    use="optional" default="false" form="unqualified"/>
<xs:attribute name="CopyDatabaseUsers" type="xs:boolean"
    use="optional" default="false" form="unqualified"/>
<xs:attribute name="CopyDatabaseRoles" type="xs:boolean"
    use="optional" default="false" form="unqualified"/>
<xs:attribute name="CopySqlServerLogins" type="xs:boolean"
    use="optional" default="false" form="unqualified"/>
<xs:attribute name="CopyObjectLevelPermissions" type="xs:boolean"
    use="optional" default="false" form="unqualified"/>
<xs:attribute name="CopyIndexes" type="xs:boolean"
    use="optional" default="false" form="unqualified"/>
<xs:attribute name="CopyTriggers" type="xs:boolean"
    use="optional" default="false" form="unqualified"/>
<xs:attribute name="CopyFullTextIndexes" type="xs:boolean"

```

```

        use="optional" default="false" form="unqualified"/>
<xs:attribute name="CopyPrimaryKeys" type="xs:boolean"
        use="optional" default="false" form="unqualified"/>
<xs:attribute name="CopyForeignKeys" type="xs:boolean"
        use="optional" default="false" form="unqualified"/>
<xs:attribute name="GenerateScriptsInUnicode" type="xs:boolean"
        use="optional" default="false" form="unqualified"/>
<xs:attribute name="SourceTranslateChar" type="xs:boolean"
        use="optional" default="false" form="unqualified"/>
<xs:attribute name="DestinationTranslateChar" type="xs:boolean"
        use="optional" default="false" form="unqualified"/>
<xs:attribute name="CopyAllDRIObjects" type="xs:boolean"
        use="optional" default="false" form="unqualified"/>
</xs:complexType>

```

The **TransferSqlServerObjectsTaskDataObjectDataType** complex type MUST NOT contain any elements or values.

The following table specifies the attributes of the **TransferSqlServerObjectsTaskDataObjectDataType** complex type.

Attribute	Description
SourceConnection	A string value that specifies a reference to the connection manager for the source of the data to be transferred. The connection manager can be referenced by its DTSID property or by its ObjectName property.
DestinationConnection	A string value that specifies a reference to the connection manager for the destination of the data to be transferred. The connection manager can be referenced by its DTSID property or by its ObjectName property.
SourceDatabase	A string value that specifies the source database for objects to be transferred.
DestinationDatabase	A string value that specifies the destination database for objects to be transferred.
CopyAllObjects	A Boolean value that specifies whether the task copies all objects or only the specified objects. TRUE specifies that all objects from the source database are copied. FALSE specifies that only the specified objects are copied.
CopyAllRules	A Boolean value that specifies whether the task copies all rule objects or only the specified rule objects. TRUE specifies that all rule objects from the source database are copied. FALSE specifies that only the rules that are specified in the RulesList attribute are copied.
CopyAllTables	A Boolean value that specifies whether the task copies all tables or only the specified tables. TRUE specifies that all tables from the source database are copied. FALSE specifies that only the tables that are specified in the TablesList attribute are copied.

Attribute	Description
CopyAllViews	A Boolean value that specifies whether the task copies all views or only the specified views. TRUE specifies that all views from the source database are copied. FALSE specifies that only the views that are specified in the ViewsList attribute are copied.
CopyAllStoredProcedures	A Boolean value that specifies whether the task copies all stored procedures or only the specified stored procedures. TRUE specifies that all stored procedures from the source database are copied. FALSE specifies that only the stored procedures specified in the StoredProceduresList attribute are copied.
CopyAllUserDefinedFunctions	A Boolean value that specifies whether the task copies all user-defined functions or only the specified user-defined functions. TRUE specifies that all user-defined functions from the source database are copied. FALSE specifies that only the user-defined functions that are specified in the UserDefinedFunctionsList attribute are copied.
CopyAllDefaults	A Boolean value that specifies whether the task copies all defaults or only the specified defaults. TRUE specifies that all defaults from the source database are copied. FALSE specifies that only the defaults specified in the DefaultsList attribute are copied.
CopyAllUserDefinedDataTypes	A Boolean value that specifies whether the task copies all user-defined data types or only the specified user-defined data types. TRUE specifies that all user-defined data types from the source database are copied. FALSE specifies that only the user-defined data types specified in the UserDefinedTypesList attribute are copied.
CopyAllPartitionFunctions	A Boolean value that specifies whether the task copies all partition functions or only the specified partition functions. TRUE specifies that all partition functions from the source database are copied. FALSE specifies that only the defaults specified in the PartitionFunctionsList attribute are copied.
CopyAllPartitionSchemas	A Boolean value that specifies whether the task copies all partition schemas or only the specified partition schemas. TRUE specifies that all partition schemas from the source database are copied. FALSE specifies that only the partition schemas specified in the PartitionSchemeList attribute are copied.
CopyAllSchemas	A Boolean value that specifies whether the task copies all schemas or only the specified schemas. TRUE specifies that all schemas from the source database are copied. FALSE specifies that only the schemas specified in the SchemasList attribute are copied.

Attribute	Description
CopyAllSqlAssemblies	A Boolean value that specifies whether the task copies all SQL assemblies or only the specified SQL assemblies. TRUE specifies that all SQL assemblies from the source database are copied. FALSE specifies that only the SQL assemblies specified in the SqlAssembliesList attribute are copied.
CopyAllUserDefinedAggregates	A Boolean value that specifies whether the task copies all user-defined aggregates or only the specified user-defined aggregates. TRUE specifies that all user-defined aggregates from the source database are copied. FALSE specifies that only the user-defined aggregates specified in the UserDefinedAggregatesList attribute are copied.
CopyAllUserDefinedTypes	A Boolean value that specifies whether the task copies all user-defined types or only the specified user-defined types. TRUE specifies that all user-defined types from the source database are copied. FALSE specifies that only the user-defined types that are specified in the UserDefinedTypesList attribute are copied.
CopyAllXmlSchemaCollections	A Boolean value that specifies whether the task copies all XML schema collections or only the specified XML schema collections. TRUE specifies that all XML schema collections from the source database are copied. FALSE specifies that only the XML schema collections that are specified in the XmlSchemaCollectionsList attribute are copied.
LoginsList	A string value that specifies the list of logins to copy.
UsersList	A string value that specifies the list of database users to copy.
RulesList	A string value that specifies the list of rules to copy.
TablesList	A string value that specifies the list of tables to copy.
ViewsList	A string value that specifies the list of views to copy.
StoredProceduresList	A string value that specifies the list of stored procedures to copy.
UserDefinedFunctionsList	A string value that specifies the list of user-defined functions to copy.
DefaultsList	A string value that specifies the list of defaults to copy.
UserDefinedDataTypesList	A string value that specifies the list of user-defined data types to copy.
PartitionFunctionsList	A string value that specifies the list of partition functions to copy.
PartitionSchemesList	A string value that specifies the list of partition schemas to copy.
SchemasList	A string value that specifies the list of schemas to copy.
SqlAssembliesList	A string value that specifies the list of SQL assemblies to copy.

Attribute	Description
UserDefinedAggregatesList	A string value that specifies the list of user-defined aggregates to copy.
UserDefinedTypesList	A string value that specifies the list of user-defined types to copy.
XmlSchemaCollectionsList	A string value that specifies the list of XML schema collections to copy.
DropObjectsFirst	<p>A Boolean value that specifies whether to drop object on the destination database before the transfer. This option is used only if the value of the CopySchema attribute is set to TRUE.</p> <p>TRUE specifies that objects on the destination server are dropped before the transfer.</p> <p>FALSE specifies that objects on the destination server are not dropped before the transfer.</p>
IncludeDependentObjects	<p>A Boolean value that specifies whether dependent objects are included with the transfer.</p> <p>TRUE specifies that dependent objects are included with the transfer.</p> <p>FALSE specifies that dependent objects are not included with the transfer.</p>
IncludeExtendedProperties	<p>A Boolean value that specifies whether extended properties are included with the transfer.</p> <p>TRUE specifies that extended properties are included with the transfer.</p> <p>FALSE specifies that extended properties are not included with the transfer.</p>
CopyData	<p>A Boolean value that specifies whether data is included with the transfer.</p> <p>TRUE specifies that data is included with the transfer.</p> <p>FALSE specifies that data is not included with the transfer.</p>
ExistingData	An enumeration value that specifies whether to append or replace existing data. This value is used only if the CopyData attribute is set to TRUE and the DropObjectsFirst attribute is set to FALSE.
CopySchema	<p>A Boolean value that specifies whether the schema is included with the transfer.</p> <p>TRUE specifies that the schema is included with the transfer.</p> <p>FALSE specifies that the schema is not included with the transfer.</p>
UseCollation	<p>A Boolean value that specifies whether the transfer includes a collation.</p> <p>TRUE specifies that a collation is included with the transfer.</p> <p>FALSE specifies that a collation is not included with the transfer.</p>
CopyDatabaseUsers	<p>A Boolean value that specifies whether database users are included in the transfer.</p> <p>TRUE specifies that database users are included with the transfer. The database users that are specified in the UsersList attribute are copied.</p> <p>FALSE specifies that database users are not included with the</p>

Attribute	Description
	transfer.
CopyDatabaseRoles	A Boolean value that specifies whether database roles are included in the transfer. TRUE specifies that database roles are included with the transfer. FALSE specifies that database roles are not included with the transfer.
CopySqlServerLogins	A Boolean value that specifies whether database logins<102> are included in the transfer. TRUE specifies that database logins are included with the transfer. FALSE specifies that database logins are not included with the transfer.
CopyObjectLevelPermissions	A Boolean value that specifies whether object-level permissions are included in the transfer. TRUE specifies that object-level permissions are included with the transfer. FALSE specifies that object level permissions are not included with the transfer.
CopyIndexes	A Boolean value that specifies whether indexes are included in the transfer. TRUE specifies that indexes are included in the transfer. FALSE specifies that indexes are not included in the transfer.
CopyTriggers	A Boolean value that specifies whether triggers are included in the transfer. TRUE specifies that triggers are included in the transfer. FALSE specifies that triggers are not included in the transfer.
CopyFullTextIndexes	A Boolean value that specifies whether indexes are included in the transfer. TRUE specifies that triggers are included in the transfer. FALSE specifies that triggers are not included in the transfer.
CopyPrimaryKeys	A Boolean value that specifies whether primary key constraints are included in the transfer. TRUE specifies that primary key constraints are included in the transfer. FALSE specifies that primary key constraints are not included in the transfer.
CopyForeignKeys	A Boolean value that specifies whether foreign key constraints are included in the transfer. TRUE specifies that foreign key constraints are included in the transfer. FALSE specifies that foreign key constraints are not included in the transfer.
GenerateScriptsInUnicode	A Boolean value that specifies whether the script MUST be generated in Unicode format. TRUE specifies that the script MUST be generated in Unicode format.

Attribute	Description
	FALSE specifies that the script MUST NOT be generated in Unicode format.
SourceTranslateChar	A Boolean value that specifies whether the transfer operation translates the codepage for characters on the source database. TRUE specifies that the transfer operation translates the codepage for characters on the source database. FALSE specifies that the transfer operation does not translate the codepage for characters on the source database.
DestinationTranslateChar	A Boolean value that specifies whether the transfer operation translates the codepage for characters on the destination database. TRUE specifies that the transfer operation translates the codepage for characters on the destination database. FALSE specifies that the transfer operation does not translate the codepage for characters on the destination database.
CopyAllDRIObjects	A Boolean value that specifies that data referential integrity (DRI) objects are included in the transfer. TRUE specifies that DRI objects are included in the transfer. FALSE specifies that DRI objects are not included in the transfer.

2.7.1.22.1 TransferSqlServerObjectsTaskExistingDataEnum

The **TransferSqlServerObjectsTaskExistingDataEnum** type contains the enumeration values for the **LoginsToTransfer** attribute.

The following is the XSD of the **TransferSqlServerObjectsTaskExistingDataEnum** type.

```
<xs:simpleType name="TransferSqlServerObjectsTaskExistingDataEnum">
  <xs:restriction base="xs:string">
    <xs:enumeration value="Replace"/>
    <xs:enumeration value="Append"/>
  </xs:restriction>
</xs:simpleType>
```

The following table specifies the enumeration values for the **TransferSqlServerObjectsTaskExistingDataEnum** type.

Enumeration value	Description
Replace	Specifies that new data replaces existing data.
Append	Specifies that new data is appended to existing data.

2.7.1.23 WebServiceTaskData

The **WebServiceTaskData** element is used to specify parameters, properties, and settings that are specific to the execution of a Web Service Task. This element resides in the [WebServiceTask](#) namespace. The [ExecutableObjectType](#) type refers to this element within an XSD **choice** element, using the XSD **ref** attribute, in the following XSD fragment.

```
<xs:element ref="WSTask:WebServiceTaskData"/>
```

2.7.1.23.1 WebServiceTask Namespace

The **WebServiceTask** namespace specifies the elements and types that are used by the Web Service Task.

The following is the XSD declaration for the **WebServiceTask** namespace.

```
xmlns:WSTask="www.microsoft.com/sqlserver/dts/tasks/webservicetask"
```

2.7.1.23.1.1 WebServiceTaskData

The following is the XSD for the element declaration for the **WebServiceTaskData** element in the [WebServiceTask](#) namespace.

```
<xs:element name="WebServiceTaskData"
  type="WSTask:WSTaskDataType"/>
```

2.7.1.23.1.1.1 WebServiceTaskDataType

The **WebServiceTaskType** complex type holds parameters, properties, and settings for the Web Service Task.

The following is the XSD for the **WebServiceTaskDataType** complex type.

```
<xs:complexType name="WSTaskDataType">
  <xs:sequence>
    <xs:element name="MethodInfo"
      type="WSTask:WebServiceTaskDataMethodInfoType"/>
  </xs:sequence>
  <xs:attribute name="ConnectionName" type="xs:string" use="optional"
    default=""/>
  <xs:attribute name="Service" type="xs:string" use="optional"
    default=""/>
  <xs:attribute name="WSDLFile" type="xs:string" use="optional"
    default=""/>
  <xs:attribute name="OverwriteWSDLFile" use="optional" default="False">
    <xs:simpleType>
      <xs:restriction base="xs:string">
        <xs:enumeration value="True"/>
        <xs:enumeration value="False"/>
      </xs:restriction>
    </xs:simpleType>
  </xs:attribute>
  <xs:attribute name="OutputType"
    type="WSTask:WebServiceTaskDataOutputTypeEnum"
    use="optional" default="File"/>
  <xs:attribute name="OutputLocation" type="xs:string" use="optional"
    default=""/>
```

</xs:complexType>

The following table provides additional information about the elements and types for the **WebServiceTaskDataType** complex type.

Element	Type definition	Description
MethodInfo	WebServiceTaskDataMethodInfoType	A complex type that specifies the method that is executed by the Web Service Task.

The following table specifies the attributes of the **WebServiceTaskDataType** complex type.

Attribute	Description
ConnectionName	A string value that specifies the name of the connection that is used to execute the Web Service Task.
Service	A string value that specifies the service name of the Web service to be executed.
WSDLFile	A string value that specifies the name of the file that contains the Web Services Description Language (WSDL) file that is used with the Web service.
OverwriteWSDLFile	An enumeration value that specifies whether to overwrite the WSDL file. "True" specifies that the WSDL file MUST be overwritten. "False" specifies that the WSDL file MUST NOT be overwritten.
OutputType	An enumeration value that specifies the destination for the output.
OutputLocation	A string values that specifies the output location. Depending on the value of the OutputType attribute, this string value contains either a variable name or a file connection reference.

2.7.1.23.1.1.1.1.1 **WebServiceTaskDataMethodInfoType**

The **WebServiceTaskDataMethodInfoType** complex type is used to specify information about the method that is called by the Web Service Task.

The following is the XSD for the **WebServiceTaskDataMethodInfoType** complex type.

```
<xs:complexType name="WebServiceTaskDataMethodInfoType">
  <xs:sequence>
    <xs:element name="Documentation" type="xs:string"
      minOccurs="0" maxOccurs="1"/>
    <xs:element name="ParamInfo"
      type="WSTask:WebServiceTaskDataParamInfoType"
      maxOccurs="unbounded"/>
  </xs:sequence>
  <xs:attribute name="MethodName" type="xs:string"/>
  <xs:attribute name="MessageName" type="xs:string"/>
</xs:complexType>
```

The following table provides additional information about the elements and types for the **WebServiceTaskDataMethodInfoType** complex type.

Element	Type definition	Description
Dcocumentation	xs:string	A string value that contains descriptive documentation for the MethodInfo element contents.
ParamInfo	WebServiceTaskDataParamInfoType	A complex type that contains information about the parameters that the called method uses.

The following table specifies additional information for the attributes of the **WebServiceTaskDataMethodInfoType** complex type.

Attribute	Description
MethodName	A string value that specifies the name of the method that is executed by the Web Service Task.
MessageName	A string value that specifies the name of the message that the Web service is accessing.

2.7.1.23.1.1.1.2 WebServiceTaskDataParamInfoType

The **WebServiceTaskDataParamInfoType** complex type is used to specify information about the method that is called by the Web Service Task.

The following is the XSD for the **WebServiceTaskDataParamInfoType** complex type.

```
<xs:complexType name="WebServiceTaskDataParamInfoType">
  <xs:sequence>
    <xs:element name="VariableValue" type="xs:string"
      minOccurs="0" maxOccurs="1"/>
    <xs:element name="PrimitiveValue" type="xs:anySimpleType"
      minOccurs="0" maxOccurs="1"/>
  </xs:sequence>
  <xs:attribute name="Name" type="xs:string"/>
  <xs:attribute name="Datatype" type="xs:string"/>
  <xs:attribute name="ParamType" type="WSTask:ParamTypeEnum"/>
  <xs:attribute name="SeqNumber" type="xs:int"/>
</xs:complexType>
```

The following table provides additional information about the elements and types for the **WebServiceTaskDataParamInfoType** complex type.

Element	Type definition	Description
VariableValue	xs:string	A string value that specifies the name of the variable that supplies the value of the parameter. This element appears only if the value of the ParamType attribute is equal to "Variable".
PrimitiveValue	xs:anySimpleType	A value of anySimpleType that contains the value of the parameter. This element appears only if the value of the ParamType attribute is equal to "Primitive".

The following table specifies additional information for the attributes of the **WebServiceTaskDataParamInfoType** complex type.

Attribute	Description
Name	A string value that specifies the name of the parameter.
Datatype	A string value that specifies the data type of the parameter. The strings that can be used for the value of the Datatype attribute are defined in the WSDL file of the Web service that is being called.
ParamType	An enumeration value that specifies the type of the parameter.
SeqNumber	An integer value that specifies the sequence number of the parameter.

2.7.1.23.1.1.1.3 WebServiceTaskDataOutputTypeEnum

The **WebServiceTaskDataOutputTypeEnum** type contains the enumeration values for the **OutputType** attribute.

The following is the XSD of the **WebServiceTaskDataOutputTypeEnum** type.

```
<xs:simpleType name="WebServiceTaskDataOutputTypeEnum">
  <xs:restriction base="xs:string">
    <xs:enumeration value="File"/>
    <xs:enumeration value="Variable"/>
  </xs:restriction>
</xs:simpleType>
```

The following table specifies the enumeration values for the **WebServiceTaskDataOutputTypeEnum** type.

Enumeration value	Description
File	Specifies that the output is directed to a file.
Variable	Specifies that the output is directed to a variable.

2.7.1.24 WMIDRTaskDataObjectDataType

The **WMIDRTaskDataObjectDataType** complex type is used to specify parameters, properties, and settings that are specific to the WMI Data Reader Task.

The following is the XSD for the **WMIDRTaskDataObjectDataType** complex type.

```
<xs:complexType name="WMIDRTaskDataObjectDataType">
  <xs:sequence/>
  <xs:attribute name="WQLQuerySourceType" type="DTS:SourceTypeEnum"
    use="optional" default="DirectInput" form="unqualified"/>
  <xs:attribute name="WQLQuerySource" type="xs:string"
    use="optional" default="" form="unqualified"/>
  <xs:attribute name="DestinationType"
    type="DTS:DestinationTypeEnum" form="unqualified"/>
```

```

        use="optional" default="FileConnection"/>
<xs:attribute name="Destination" type="xs:string"
        use="optional" default="" form="unqualified"/>
<xs:attribute name="OverwriteDestination"
        type="DTS:WMITaskDataOverwriteDestinationEnum"
        use="optional" default="KeepOriginal" form="unqualified"/>
<xs:attribute name="OutputType"
        type="DTS:WMITaskDataOutputTypeEnum"
        use="optional" default="DataTable" form="unqualified"/>
<xs:attribute name="WMIConnectionName" type="xs:string"
        use="optional" default="" form="unqualified"/>
</xs:complexType>

```

The **WMIDRTaskDataObjectDataType** complex type MUST NOT contain any elements or values.

The following table specifies the attributes of the **WMIDRTaskDataObjectDataType** complex type.

Attribute	Description
WQLQuerySourceType	An enumeration value that specifies where the source for the WMI Query Language (WQL) is found.
WQLQuerySource	A string value that specifies the source of the WQL query. This value is used only if the WQLQuerySourceType value is set to "DirectInput".
DestinationType	An enumeration value that specifies the type of the destination where results are sent.
Destination	A string value that specifies the destination where results are sent. This attribute contains a variable name or a connection manager reference, depending on the value of the DestinationType attribute.
OverwriteDestination	An enumeration value that specifies how output that already exists at the destination is handled.
OutputType	An enumeration value that specifies the type of values that are output and the way in which the output values are formatted.
WMIConnectionName	A string value that specifies the connection name. The connection name is a reference to a connection manager; the connection name can match either the DTSID property of the connection manager or the ObjectName property of the connection manager.

2.7.1.24.1 WMITaskDataOverwriteDestinationEnum

The **WMITaskDataOverwriteDestinationEnum** type contains the enumeration values for the **OverwriteDestination** attribute.

The following is the XSD of the **WMITaskDataOverwriteDestinationEnum** type.

```

<xs:simpleType name="WMITaskDataOverwriteDestinationEnum">
  <xs:restriction base="xs:string">
    <xs:enumeration value="KeepOriginal"/>
    <xs:enumeration value="AppendToDestination"/>
    <xs:enumeration value="OverwriteDestination"/>
  </xs:restriction>
</xs:simpleType>

```

```
</xs:simpleType>
```

The following table specifies the enumeration values for the **WMITaskDataOverwriteDestinationEnum** type.

Enumeration value	Description
KeepOriginal	Specifies that the original data is kept and that no data is overwritten.
AppendToDestination	Specifies that new data from this task is appended to any existing data at the destination.
OverwriteDestination	Specifies that any existing destination data is overwritten with new data from the results of this task.

2.7.1.24.2 WMITaskDataOutputTypeEnum

The **WMITaskDataOutputTypeEnum** type contains the enumeration values for the **OutputType** attribute.

The following is the XSD of the **WMITaskDataOutputTypeEnum** type.

```
<xs:simpleType name="WMITaskDataOutputTypeEnum">  
  <xs:restriction base="xs:string">  
    <xs:enumeration value="DataTable"/>  
    <xs:enumeration value="PropertyNameAndValue"/>  
    <xs:enumeration value="PropertyValue"/>  
  </xs:restriction>  
</xs:simpleType>
```

The following table specifies the enumeration values for the **WMITaskDataOutputTypeEnum** type.

Enumeration value	Description
DataTable	Specifies that the output is formatted as a data table.
PropertyNameAndValue	Specifies that the output is in the form of property name/property value pairs, with one pair on each line.
PropertyValue	Specifies that only property values are output, one per line.

2.7.1.25 WMIEWTaskDataObjectDataType

The **WMIEWTaskDataObjectDataType** complex type is used to specify parameters, properties, and settings that are specific to the WMI Event Watcher Task.

The following is the XSD for the **WMIEWTaskDataObjectDataType** complex type.

```
<xs:complexType name="WMIEWTaskDataObjectDataType">  
  <xs:sequence/>  
  <xs:attribute name="WMIConnectionName" type="xs:string"/>  
</xs:complexType>
```

```

        use="optional" default="" form="unqualified"/>
<xs:attribute name="WQLQuerySourceType" type="DTS:SourceTypeEnum"
        use="optional" default="DirectInput" form="unqualified"/>
<xs:attribute name="WQLQuerySource" type="xs:string"
        use="optional" default="" form="unqualified"/>
<xs:attribute name="ActionAtEvent"
        type="DTS:WMIEWTaskDataActionAtEventEnum"
        use="optional" default="LogTheEventAndFireDTSEvent"
        form="unqualified"/>
<xs:attribute name="AfterEvent"
        type="DTS:WMIEWTaskDataAfterEventEnum"
        use="optional" default="ReturnWithSuccess"
        form="unqualified"/>
<xs:attribute name="ActionAtTimeout"
        type="DTS:WMIEWTaskDataActionAtTimeoutEnum"
        use="optional" default="LogTimeoutAndFireDTSEvent"
        form="unqualified"/>
<xs:attribute name="AfterTimeout"
        type="DTS:WMIEWTaskDataAfterEventEnum"
        use="optional" default="ReturnWithFailure"
        form="unqualified"/>
<xs:attribute name="NumberOfEvents" type="xs:int"
        use="optional" default="1" form="unqualified"/>
<xs:attribute name="Timeout" type="xs:int" form="unqualified"
        use="optional" default="0"/>
</xs:complexType>

```

The **WMIEWTaskDataObjectDataType** complex type MUST NOT contain any elements or values.

The following table specifies the attributes of the **WMIEWTaskDataObjectDataType** complex type.

Attribute	Description
WMIConnectionName	A string value that specifies the connection name. The WMIConnectionName value is a reference to a connection manager; the connection name can match either the DTSID property of the connection manager or the ObjectName property of the connection manager.
WQLQuerySourceType	An enumeration value that specifies where the source for the WQL query is found.
WQLQuerySource	A string value that specifies the source of the WQL query. This value is used only if the WQLQuerySourceType value is set to "DirectInput".
ActionAtEvent	An enumeration value that specifies the action to take when the event occurs.
AfterEvent	An enumeration value that specifies the action to take after the event occurs.
ActionAtTimeout	An enumeration value that specifies the action to take when timeout occurs.
AfterTimeout	An enumeration value that specifies the action to take after timeout occurs.
NumberOfEvents	An integer value that specifies the number of events that the task watches.
Timeout	An integer value that specifies the timeout interval for the task, in seconds.

2.7.1.25.1 WMIEWTaskDataActionAtEventEnum

The **WMIEWActionAtEventEnum** type contains the enumeration values for the **ActionAtEvent** attribute and the **ActionAtTimeout** attribute.

The following is the XSD of the **WMIEWActionAtEventEnum** type.

```
<xs:simpleType name="WMIEWTaskDataActionAtEventEnum">
  <xs:restriction base="xs:string">
    <xs:enumeration value="LogTheEventAndFireDTSEvent"/>
    <xs:enumeration value="LogTheEvent"/>
  </xs:restriction>
</xs:simpleType>
```

The following table specifies the enumeration values for the **WMIEWActionAtEventEnum** type.

Enumeration value	Description
LogTheEventAndFireDTSEvent	Specifies that the event is logged and a DTS event is fired.
LogTheEvent	Specifies that the event is logged only.

2.7.1.25.2 WMIEWTaskDataAfterEventEnum

The **WMIEWAfterEventEnum** type contains the enumeration values for the **ActionAfterEvent** attribute.

The following is the XSD of the **WMIEWAfterEventEnum** type.

```
<xs:simpleType name="WMIEWTaskDataAfterEventEnum">
  <xs:restriction base="xs:string">
    <xs:enumeration value="WatchfortheEventAgain"/>
    <xs:enumeration value="ReturnWithSuccess"/>
    <xs:enumeration value="ReturnWithFailure"/>
  </xs:restriction>
</xs:simpleType>
```

The following table specifies the enumeration values for the **WMIEWAfterEventEnum** type.

Enumeration value	Description
WatchfortheEventAgain	Specifies that the event is watched for again.
ReturnWithSuccess	Specifies that a success exit value is returned.
ReturnWithFailure	Specifies that a failure exit value is returned.

2.7.1.25.3 WMIEWTaskDataActionAtTimeoutEnum

The **WMIEWActionAtTimeoutEnum** type contains the enumeration values for the **ActionAtTimeout** attribute.

The following is the XSD of the **WMIEWActionAtTimeoutEnum** type.

```
<xs:simpleType name="WMIEWTaskDataActionAtTimeoutEnum">
  <xs:restriction base="xs:string">
    <xs:enumeration value="LogTimeoutAndFireDTSEvent"/>
    <xs:enumeration value="LogTimeout"/>
  </xs:restriction>
</xs:simpleType>
```

The following table specifies the enumeration values for the **WMIEWActionAtTimeoutEnum** type.

Enumeration value	Description
LogTimeoutAndFireDTSEvent	Specifies that a timeout event is logged and a DTS event is fired.
LogTimeout	Specifies that a timeout event is logged only.

2.7.1.26 XMLTaskDataObjectDataType

The **XMLTaskDataObjectDataType** complex type is used to specify parameters, properties, and settings that are specific to the XML Task.

The following is the XSD for the **XMLTaskDataObjectDataType** complex type.

```
<xs:complexType name="XMLTaskDataObjectDataType">
  <xs:sequence>
  </xs:sequence>
  <xs:attribute name="OperationType" form="unqualified"
    type="DTS:XMLTaskOperationTypeEnum"
    use="optional" default="Diff"/>
  <xs:attribute name="SourceType" type="DTS:SourceTypeEnum"
    use="optional" default="FileConnection"
    form="unqualified"/>
  <xs:attribute name="Source" type="xs:string" form="unqualified"
    use="optional" default="" />
  <xs:attribute name="SecondOperandType" type="DTS:SourceTypeEnum"
    use="optional" default="DirectInput" form="unqualified"/>
  <xs:attribute name="SecondOperand" type="xs:string"
    use="optional" default="" form="unqualified"/>
  <xs:attribute name="SaveOperationResult" form="unqualified"
    use="optional" default="False">
    <xs:simpleType>
      <xs:restriction base="xs:string">
        <xs:enumeration value="True"/>
        <xs:enumeration value="False"/>
      </xs:restriction>
    </xs:simpleType>
  </xs:attribute>
  <xs:attribute name="DestinationType"
    type="DTS:DestinationTypeEnum" form="unqualified"
    use="optional" default="FileConnection" />
  <xs:attribute name="Destination" type="xs:string"
    use="optional" default="" form="unqualified"/>
  <xs:attribute name="OverwriteDestination" form="unqualified"
```

```

        use="optional" default="False">
    <xs:simpleType>
        <xs:restriction base="xs:string">
            <xs:enumeration value="True"/>
            <xs:enumeration value="False"/>
        </xs:restriction>
    </xs:simpleType>
</xs:attribute>
<xs:attribute name="FailOpOnValidationFail" form="unqualified"
    use="optional" default="False">
    <xs:simpleType>
        <xs:restriction base="xs:string">
            <xs:enumeration value="True"/>
            <xs:enumeration value="False"/>
        </xs:restriction>
    </xs:simpleType>
</xs:attribute>
<xs:attribute name="FailOpOnDifference" form="unqualified"
    use="optional" default="False">
    <xs:simpleType>
        <xs:restriction base="xs:string">
            <xs:enumeration value="True"/>
            <xs:enumeration value="False"/>
        </xs:restriction>
    </xs:simpleType>
</xs:attribute>
<xs:attribute name="SaveDiffGram" form="unqualified"
    use="optional" default="False">
    <xs:simpleType>
        <xs:restriction base="xs:string">
            <xs:enumeration value="True"/>
            <xs:enumeration value="False"/>
        </xs:restriction>
    </xs:simpleType>
</xs:attribute>
<xs:attribute name="DiffGramDestinationType" form="unqualified"
    type="DTS:DestinationTypeEnum" use="optional"
    default="FileConnection"/>
<xs:attribute name="DiffGramDestination" form="unqualified"
    type="xs:string" use="optional" default=""/>
<xs:attribute name="DiffOptions" type="DTS:XMLTaskDiffOptionsType"
    use="optional" default="0" form="unqualified"/>
<xs:attribute name="DiffAlgorithm" form="unqualified"
    type="DTS:XMLTaskDiffAlgorithmEnum"
    use="optional" default="Auto"/>
<xs:attribute name="XPathStringSourceType"
    type="DTS:SourceTypeEnum" form="unqualified"
    use="optional" default="DirectInput"/>
<xs:attribute name="XPathStringSource" type="xs:string"
    use="optional" default="" form="unqualified"/>
<xs:attribute name="XPathOperation" form="unqualified"
    type="DTS:XMLTaskXPathOperationEnum"
    use="optional" default="Evaluation" />
<xs:attribute name="PutResultInOneNode" form="unqualified"
    use="optional" default="False">
    <xs:simpleType>
        <xs:restriction base="xs:string">
            <xs:enumeration value="True"/>
            <xs:enumeration value="False"/>
        </xs:restriction>
    </xs:simpleType>

```

```

        </xs:restriction>
    </xs:simpleType>
</xs:attribute>
<xs:attribute name="ValidationType"
              type="DTS:XMLTaskValidationTypeEnum"
              use="optional" default="XSD" form="unqualified"/>
</xs:complexType>

```

The **XMLTaskDataObjectDataType** complex type MUST NOT contain any elements or values.

The following table specifies the attributes of the **XMLTaskDataObjectDataType** complex type.

Attribute	Description
OperationType	An enumeration value that specifies the type of operation that is performed by the XML Task.
SourceType	An enumeration value that specifies the source type for the XML document that is used by the XML Task.
Source	A string value that contains the source. The content of the string is dependent upon the value of the SourceType attribute.
SecondOperandType	An enumeration value that selects the source type of the second document that is used by the XML Task.
SecondOperand	A string value that contains the source for the second operation. The content of the string is dependent upon the value of the SecondOperandType attribute.
SaveOperationResult	An enumeration value that specifies whether to save the result of the operation. "True" specifies that the result of the operation is saved. "False" specifies that the result of the operation is not saved.
DestinationType	An enumeration value that specifies the type of the destination.
Destination	A string value that specifies the destination. The content of the string is dependent upon the value of the DestinationType attribute.
OverwriteDestination	An enumeration value that specifies whether to overwrite any content that already exists at the destination. "True" specifies that the existing content at the destination is overwritten. "False" specifies that existing content at the destination is not overwritten.
FailOpOnValidationFail	An enumeration value that specifies whether the operation fails if the document fails to validate. "True" specifies that the operation fails if the document fails to validate. "False" specifies that the operation does not necessarily fail if the document fails to validate.
FailOpOnDifference	An enumeration value that specifies whether to fail the operation if there is a difference detected. "True" specifies that the operation fails if there is a difference. "False" specifies that the operation does not necessarily fail if there is a difference.

Attribute	Description
SaveDiffGram	An enumeration value that specifies whether to save the result of a Diff operation as a DiffGram document. "True" specifies that the result can be saved as a DiffGram document. "False" specifies that the result is not saved.
DiffGramDestinationType	An enumeration value that specifies the type of the destination of the DiffGram output.
DiffGramDestination	A string value that specifies the destination of the DiffGram output. The content of the string varies with the value of the DiffGramDestinationType attribute value.
DiffOptions	An integer value that specifies the options to be used in the Diff operation. This integer is a bitmask value.
DiffAlgorithm	An enumeration value that specifies the algorithm to use for the Diff operation.
XPathStringSourceType	An enumeration value that specifies the type of the source of the XPATH string.
XPathStringSource	A string value that specifies the XPATH string source. The content of the string is dependent upon the value of the XPathStringSourceType attribute.
XPathOperation	An enumeration value that specifies the type of XPATH operation to perform.
PutResultInOneNode	An enumeration value that specifies whether to put the output result in one XML node. "True" specifies that the output result is put in one node. "False" specifies that the output result does not need to be put in one node.
ValidationType	An enumeration value that specifies the type of validation to perform.

2.7.1.26.1 XMLTaskOperationTypeEnum

The **XMLTaskOperationTypeEnum** type contains the enumeration values for the **OperationType** attribute.

The following is the XSD of the **XMLTaskOperationTypeEnum** type.

```
<xs:simpleType name="XMLTaskDataOperationTypeEnum">
  <xs:restriction base="xs:string">
    <xs:enumeration value="Diff"/>
    <xs:enumeration value="Validate"/>
    <xs:enumeration value="Merge"/>
    <xs:enumeration value="XSLT"/>
    <xs:enumeration value="XPATH"/>
    <xs:enumeration value="Patch"/>
  </xs:restriction>
</xs:simpleType>
```

The following table specifies the enumeration values for the **XMLTaskOperationTypeEnum** type.

Enumeration value	Description
Diff	Specifies that two XML documents are compared.
Validate	Specifies that the XML is validated against an XSD or a DTD.
Merge	Specifies that two XML documents are merged.
XSLT	Specifies that an XSLT transformation is run on an XML document.
XPATH	Specifies that XPATH queries and evaluations are performed.
Patch	Specifies that the output of a Diff operation is applied to an XML document to create a new document.

2.7.1.26.2 XMLTaskDiffOptionsType

The **XMLTaskDiffOptionsType** type is the type of the value that is used for the **DiffOptions** attribute. The **XMLTaskDiffOptionsType** type is a bitmask.

The following is the XSD of the **XMLTaskDiffOptionsType** type.

```
<xs:simpleType name="XMLTaskDiffOptionsType">
  <xs:restriction base="xs:int">
    <xs:minInclusive value="0"/>
    <xs:maxInclusive value="255"/>
  </xs:restriction>
</xs:simpleType>
```

The bitmask value for the **XMLTaskDiffOptionsType** type is computed according to the following table. The table shows the value for each option that is enabled. The value for the **XMLTaskDiffOptionsType** type is the sum of the values for the options that are enabled. A value of "0" for the **XMLTaskDiffOptionsType** type means that none of the options in the table are selected.

Value	Option
1	Specifies that the order of child nodes is ignored.
2	Specifies that comment nodes are not compared.
4	Specifies that processing instructions are not compared.
8	Specifies that white space is ignored. Significant white spaces are not compared, and all text nodes are normalized by discarding any leading and trailing white space characters (#x9, #x10, #x13, #x20) and by replacing sequences of white space characters with a single space (#x20) character.
16	Specifies that namespace names of elements and attributes are ignored. This option also implies that name prefixes are ignored. When this option is selected, two names that have the same local name but that have a different namespace URI and prefix are treated as the same names.

Value	Option
32	Specifies that the prefixes of element and attribute names are not compared. When this option is selected, two names that have the same local name and namespace URI but that have a different prefix are treated as the same names.
64	Specifies that the XML declaration is ignored.
128	Specifies that the Document Type Declaration (DTD) is ignored.

2.7.1.26.3 XMLTaskDiffAlgorithmEnum

The **XMLTaskDiffAlgorithmEnum** type contains the enumeration values for the **DiffAlgorithm** attribute.

The following is the XSD of the **XMLTaskDiffAlgorithmEnum** type.

```
<xs:simpleType name="XMLTaskDiffAlgorithmEnum">
  <xs:restriction base="xs:string">
    <xs:enumeration value="Auto"/>
    <xs:enumeration value="Fast"/>
    <xs:enumeration value="Precise"/>
  </xs:restriction>
</xs:simpleType>
```

The following table specifies the enumeration values for the **XMLTaskDiffAlgorithmEnum** type.

Enumeration value	Description
Auto	Specifies that the XML Task chooses which algorithm to use.
Fast	Specifies that a fast, but less precise, algorithm is used.
Precise	Specifies that a precise diff algorithm is used.

2.7.1.26.4 XMLTaskXPathOperationEnum

The **XMLTaskXPathOperationEnum** type contains the enumeration values for the **XPathOperation** attribute.

The following is the XSD of the **XMLTaskXPathOperationEnum** type.

```
<xs:simpleType name="XMLTaskXPathOperationEnum">
  <xs:restriction base="xs:string">
    <xs:enumeration value="Evaluation"/>
    <xs:enumeration value="NodeList"/>
    <xs:enumeration value="Values"/>
  </xs:restriction>
</xs:simpleType>
```

The following table specifies the enumeration values for the **XMLTaskXPathOperationEnum** type.

Enumeration value	Description
Evaluation	Specifies that the results of an XPATH function are returned.
NodeList	Specifies that selected nodes of an XPATH operation are returned as an XML fragment.
Values	Specifies that the inner text value of all selected nodes are returned, concatenated into a string.

2.7.1.26.5 XMLTaskValidationTypeEnum

The **XMLTaskValidationTypeEnum** type contains the enumeration values for the **ValidationType** attribute.

The following is the XSD of the **XMLTaskValidationTypeEnum** type.

```
<xs:simpleType name="XMLTaskValidationTypeEnum">
  <xs:restriction base="xs:string">
    <xs:enumeration value="DTD"/>
    <xs:enumeration value="XSD"/>
  </xs:restriction>
</xs:simpleType>
```

The following table specifies the enumeration values for the **XMLTaskValidationTypeEnum** type.

Enumeration value	Description
DTD	Specifies that a DTD is used to validate an XML document.
XSD	Specifies that an XSD is used to validate an XML document.

2.8 Other Types for Package and Non-Package Executables

2.8.1 PropertyElementBaseType

A **Property** element is commonly used throughout the DTSX structure. The **PropertyElementBaseType** complex type provides a base type that many declarations of the **Property** element use for extension.

The following is the XSD of the **PropertyElementBaseType** complex type.

```
<xs:complexType name="PropertyElementBaseType">
  <xs:simpleContent>
    <xs:extension base="xs:anySimpleType">
      <xs:attribute name="DataType" type="DTS:DtsDataTypeEnum"/>
    </xs:extension>
  </xs:simpleContent>
</xs:complexType>
```

Note that the XSD for the **PropertyElementBaseType** complex type allows the type of the value in the element to be **xs:anySimpleType**. However, in individual cases, there are constraints on what the **Property** element value is allowed to be. The additional constraints **MUST** be followed. When such constraints are present, they are specified in the sections where the **Property** element is referenced.

The following table provides additional information about the attributes, types, and constraints for the **PropertyElementBaseType** complex type.

Element	Type definition	Description
DataType	None	If this optional attribute is specified, the data type of the property element's value MUST be of the specified DataType . Otherwise, the data type of the Property element's value is xs:anySimpleType .

2.8.1.1 DtsDataTypeEnum

The **DtsDataTypeEnum** type contains the values that can be specified for the **DTS:DataType** attribute. The value for the element for which a value from the **DtsDataTypeEnum** type is specified as the attribute value **MUST** be of the type that corresponds to the integer value of the enumeration as described in the following table.

The following is the XSD of the **DtsDataTypeEnum** type.

```
<xs:simpleType name="DtsDataTypeEnum">
  <xs:restriction base="xs:int">
    <xs:enumeration value="0"/>
    <xs:enumeration value="1"/>
    <xs:enumeration value="2"/>
    <xs:enumeration value="3"/>
    <xs:enumeration value="4"/>
    <xs:enumeration value="5"/>
    <xs:enumeration value="6"/>
    <xs:enumeration value="7"/>
    <xs:enumeration value="8"/>
    <xs:enumeration value="11"/>
    <xs:enumeration value="13"/>
    <xs:enumeration value="14"/>
    <xs:enumeration value="16"/>
    <xs:enumeration value="17"/>
    <xs:enumeration value="18"/>
    <xs:enumeration value="19"/>
    <xs:enumeration value="20"/>
    <xs:enumeration value="21"/>
    <xs:enumeration value="22"/>
    <xs:enumeration value="23"/>
    <xs:enumeration value="64"/>
    <xs:enumeration value="72"/>
    <xs:enumeration value="129"/>
    <xs:enumeration value="130"/>
    <xs:enumeration value="131"/>
    <xs:enumeration value="133"/>
    <xs:enumeration value="134"/>
    <xs:enumeration value="135"/>
    <xs:enumeration value="139"/>
  </xs:restriction>
</xs:simpleType>
```



```

    <xs:enumeration value="145"/>
    <xs:enumeration value="146"/>
  </xs:restriction>
</xs:simpleType>

```

The following table specifies the enumeration values for the **DtsDataTypeEnum** type.

Enumeration value	Type for enumeration value
0	Empty value.
1	Null value.
2	Two-byte integer.
3	Four-byte integer.
4	Four-byte real.
5	Eight-byte real.
6	Currency.
7	Date.
8	BSTR.
11	Boolean.
13	Object.
14	Decimal.
16	One-byte integer.
17	One-byte unsigned integer.
18	Two-byte unsigned integer.
19	Four-byte unsigned integer.
20	Eight-byte integer.
21	Eight-byte unsigned integer.
22	Integer.
23	Unsigned integer.
64	An unsigned 64-bit date/time value. Represents the number of 100 nanosecond units since the start of January 1, 1601.
72	GUID.
129	A variable-length string with a specified maximum length.
130	Null-terminated Unicode character string with maximum length of 8000 characters.

Enumeration value	Type for enumeration value
131	Numeric.
133	DbDate , a structure that consists of year, month, day.
134	DbTime , a structure that consists of hour, minute, second.
135	DbTimeStamp , a structure that consists of year, month, day, hour, minute, seconds, and fractional parts.
139	Varnumeric , a structure that can hold very large numeric values.
145	Same as value 134, but includes fractional seconds.
146	Same as value 135, but includes a time zone offset.

2.8.2 PropertyExpressionElementType

The **PropertyExpressionElementType** complex type specifies the type for the **PropertyExpression** element. The **PropertyExpression** element is commonly used throughout the DTSX structure.

The following is the XSD of the **PropertyExpressionElementType** complex type.

```
<xs:complexType name="PropertyExpressionElementType">
  <xs:simpleContent>
    <xs:extension base="xs:anySimpleType">
      <xs:attribute name="Name" type="xs:string" use="required"/>
    </xs:extension>
  </xs:simpleContent>
</xs:complexType>
```

The following table provides additional information about the attributes and types for the **PropertyExpressionElementType** complex type.

Attribute	Constraints	Description
Name	The string given MUST be one of the valid Property element Name attribute values for a Property element attribute on the same object. Or, the string given MUST be a property of a task executable that is defined within the ObjectData element of that task executable.	Specifies the Name attribute of the PropertyExpression element. Each named property has its own use and interpretation.

2.8.3 LoggingOptionsType

The **LoggingOptionsType** complex type contains information about how logging and filtering of logging information is performed in the containing executable.

The following is the XSD of the **LoggingOptionsType** complex type.

```

<xs:complexType name="LoggingOptionsType">
  <xs:sequence>
    <xs:element name="Property"
      type="DTS:LoggingOptionsPropertyElementType"
      minOccurs="0" maxOccurs="unbounded"/>
    </xs:element>
    <xs:element name="PropertyExpression"
      type="DTS:PropertyExpressionElementType"
      minOccurs="0" maxOccurs="unbounded"/>
    <xs:element name="SelectedLogProviders" minOccurs="0"
      type="DTS:SelectedLogProvidersType"/>
  </xs:sequence>
  <xs:attributeGroup ref="DTS:LoggingOptionsAttributeGroup"/>
</xs:complexType>

```

As the XSD shows, the **Property** element of the **LoggingOptionsType** complex type uses a different base type than the **Property** element does for most other objects in the DTSX structure.

The following table provides additional information about the elements, types, and constraints for the **LoggingOptionsType** complex type.

Element	Additional constraints	Type definition	Description
Property	In some cases, constraints are placed on the Property element's value for specific values of the Name attribute of the Property element. If such constraints exist, they are specified where the meaning of the particular property name is specified. These constraints MUST be followed. If the optional DataType attribute is present, the value of the Property element MUST be of the type indicated by the DataType attribute. If the Name attribute of the Property is not equal to "ColumnFilter", the Property element MUST NOT have child elements. If the Name attribute equals "ColumnFilter", the Property element is a complex type. For more information, see	Inline in the XSD in this section.	Property elements contain values for many different properties associated with an instance of the containing Executable element, according to the Name attribute of each Property element.

Element	Additional constraints	Type definition	Description
	Property Name=ColumnFilter.		
PropertyExpression	Additional constraints exist for the PropertyExpression element. These constraints MUST be followed.	PropertyExpressionElementType	The PropertyExpression element serves the same purpose as specified for the Property element except that an expression that is evaluated at run time is contained in the element's value that is stored in the Microsoft® SQL Server® Integration Services (SSIS) file format.
SelectedLogProvider	None	SelectedLogProviderType	Contains a reference to the log provider that is to be used.

2.8.3.1 LoggingOptionsPropertyElementType

The **LoggingOptionsPropertyElementType** complex type is the type of the **Property** element when it appears as a child element to a **LoggingOptions** element. This type differs from the type for the **Property** element in most other places in this document.

The following is the XSD of the **LoggingOptionsPropertyElementType** complex type.

```
<xs:complexType name="LoggingOptionsPropertyElementType" mixed="true">
  <xs:sequence>
    <xs:element name="Property" minOccurs="0" maxOccurs="unbounded">
      <xs:complexType>
        <xs:simpleContent>
          <xs:extension base="xs:anySimpleType">
            <xs:attribute name="Name"
              type="DTS:ColumnEventFilterPropertyNameEnum"
              use="required"/>
            <xs:attribute name="DataType" type="DTS:DtsDataTypeEnum"/>
          </xs:extension>
        </xs:simpleContent>
      </xs:complexType>
    </xs:element>
  </xs:sequence>
  <xs:attribute name="Name"
    type="DTS:LoggingOptionsPropertyNameEnum"
    use="required"/>
  <xs:attribute name="DataType" type="DTS:DtsDataTypeEnum"/>
  <xs:attribute name="EventName" type="xs:string"/>
</xs:complexType>
```

The following table provides additional information about the attributes and types for the **Property** element and the **Property** element that may be a child element to the **Property** element. In the case of **LoggingOptions**, the **Property** element is of type **LoggingOptionsPropertyElementType**, and these attributes are declared in that type definition.

Attribute	Description
Name	Specifies the name of the Property element. Each named property has its own use and interpretation. The explanation for the interpretation of each named property is given with the definition of the type for the Name attribute.
DataType	The type of the value of the Property element. If present, the Property element value MUST be of this type.
EventName	The name of the event to which a column filter applies.

When the **Property** element has a **Name** attribute value of "ColumnFilter", the **Property** element MUST be a complex type. This complex type contains additional **Property** elements. For more information, see [Property Name=ColumnFilter](#).

2.8.3.1.1 LoggingOptionsPropertyNameEnum

The **LoggingOptionsPropertyNameEnum** type contains the values for the **Name** attribute of the **Property** element that are allowed for the **Property** element of the [LoggingOptionsType](#) complex type.

The following is the XSD of the **LoggingOptionsPropertyNameEnum** type.

```
<xs:simpleType name="LoggingOptionsPropertyNameEnum">
  <xs:restriction base="xs:string">
    <xs:enumeration value="EventFilter"/>
    <xs:enumeration value="ColumnFilter"/>
  </xs:restriction>
</xs:simpleType>
```

The following table specifies the enumeration values for the **LoggingOptionsPropertyNameEnum** type.

Property name	Description
EventFilter	A string that contains information about the events that are being filtered on.
ColumnFilter	Contains the definition of how the columns will be filtered. For additional restrictions, see Property Name=ColumnFilter .

2.8.3.1.1.1 Property Name=ColumnFilter

When the **Property** element's **Name** attribute value is ColumnFilter, the **Property** element is a complex element and MUST contain additional child **Property** elements, as allowed for in the XSD. These child **Property** elements also have a **Name** attribute. The **Name** attribute for the child elements MUST be of type **ColumnEventFilterPropertyNameEnum**.

The following is the XSD of the **ColumnEventFilterPropertyNameEnum** type.

```

<xs:simpleType name="ColumnEventFilterPropertyNameEnum">
  <xs:restriction base="xs:string">
    <xs:enumeration value="Computer"/>
    <xs:enumeration value="Operator"/>
    <xs:enumeration value="SourceName"/>
    <xs:enumeration value="SourceID"/>
    <xs:enumeration value="ExecutionID"/>
    <xs:enumeration value="MessageText"/>
    <xs:enumeration value="DataBytes"/>
  </xs:restriction>
</xs:simpleType>

```

The following table specifies the interpretation of the values in the enumeration. For all of the **Property** Names listed in this table, the element value **MUST** be -1 for TRUE and 0 for FALSE.

Property name	Description
Computer	Specifies whether the local computer name is included in the log entry.
Operator	Specifies whether the user account is included in the log entry.
SourceName	Specifies whether the name of the task that caused the event is included in the log entry.
SourceID	Specifies whether the GUID of the task that caused the event is included in the log entry.
ExecutionID	Specifies whether the unique package GUID is included in the log entry.
MessageText	Specifies whether message text is included in the log entry.
DataBytes	Specifies whether a byte array is included in the log entry.

2.8.3.2 SelectedLogProvidersType

The **SelectedLogProvidersType** complex type is the container type for a collection of elements of type [SelectedLogProviderType](#).

The following is the XSD of the **SelectedLogProvidersType** complex type.

```

<xs:complexType name="SelectedLogProvidersType">
  <xs:sequence>
    <xs:element name="SelectedLogProvider"
      type="DTS:SelectedLogProviderType"
      minOccurs="0" maxOccurs="unbounded"/>
  </xs:sequence>
</xs:complexType>

```

The following table provides additional information about the elements, types, and constraints for the **SelectedLogProvidersType** complex type.

Element	Type definition	Description
SelectedLogProvider	SelectedLogProviderType	Specifies a log provider that applies to the element that contains the collection.

2.8.3.2.1 SelectedLogProviderType

The **SelectedLogProviderType** complex type is a reference to the log provider to be used for the logging that is selected within the **LoggingOptions** element.

The following is the XSD of the **SelectedLogProviderType** complex type.

```
<xs:complexType name="SelectedLogProviderType">
  <xs:sequence/>
  <xs:attribute name="InstanceID" type="DTS:uuid"/>
</xs:complexType>
```

The following table provides additional information about the attributes and types for the **SelectedLogProviderType** complex type.

Attribute	Description
InstanceID	A reference to the DTSID property for a LogProvider that is contained in the package. The DTSID property is contained in the BasePropertyAttributeGroup attribute group.

2.8.3.3 LoggingOptionsAttributeGroup

The **LoggingOptionsAttributeGroup** attribute group contains the attributes for the [LoggingOptionsType](#) complex type.

The following is the XSD for the **LoggingOptionsAttributeGroup** attribute group.

```
<xs:attributeGroup name="LoggingOptionsAttributeGroup">
  <xs:attribute name="LoggingMode" type="DTS:LoggingModeEnum" default="0"
    use="optional" form="qualified"/>
  <xs:attribute name="FilterKind" type="DTS:FilterKindEnum" default="1"
    use="optional" form="qualified"/>
  <xs:attribute name="EventFilter" type="xs:string" default=""
    use="optional" form="qualified"/>
</xs:attributeGroup>
```

The following table specifies the attributes for the **LoggingOptionsAttributeGroup** attribute group.

Attribute	Description
LoggingMode	An enumeration value that specifies the logging mode.
FilterKind	An enumeration value that specifies whether filtering is done by inclusion or exclusion.
EventFilter	A string value that contains information about the events that are being filtered on.

2.8.3.3.1 LoggingModeEnum

The **LoggingModeEnum** type contains the enumeration values that specify the available logging modes.

The following is the XSD of the **LoggingModeEnum** type.

```
<xs:simpleType name="LoggingModeEnum">
  <xs:restriction base="xs:int">
    <xs:minInclusive value="0"/>
    <xs:maxInclusive value="2"/>
  </xs:restriction>
</xs:simpleType>
```

The following table specifies the descriptions for the enumeration values of the **LoggingModeEnum** type.

Enumeration value	Type of logging mode specified
0	Use Parent Setting.
1	Enabled.
2	Disabled.

2.8.3.3.2 FilterKindEnum

The **FilterKindEnum** type contains the enumeration values that specify whether filtering is done by inclusion or exclusion.

The following is the XSD of the **FilterKindEnum** type.

```
<xs:simpleType name="FilterKindEnum">
  <xs:restriction base="xs:int">
    <xs:enumeration value="0"/>
    <xs:enumeration value="1"/>
  </xs:restriction>
</xs:simpleType>
```

The following table specifies the descriptions for the enumeration values of the **FilterKindEnum** type.

Enumeration value	Type of filtering specified
0	Filter by inclusion.
1	Filter by exclusion.

2.8.4 VariablesType

The **VariablesType** complex type is the container type for a collection of elements of type [VariableType](#).

The following is the XSD of the **VariablesType** type.

```
<xs:complexType name="VariablesType">
  <xs:sequence>
    <xs:element name="Variable" type="DTS:VariableType"
      minOccurs="0" maxOccurs="unbounded"/>
  </xs:sequence>
</xs:complexType>
```

The following table provides additional information about the elements, types, and constraints for the **VariablesType** complex type.

Element	Type definition	Description
Variable	VariableType	Specifies a variable that applies to the element that contains the collection.

2.8.4.1 VariableType

The **VariableType** complex type is used to specify variables that are available to the package. The variables are evaluated at run time.

The following is the XSD of the **VariableType** complex type.

```
<xs:complexType name="VariableType">
  <xs:sequence>
    <xs:element name="PropertyExpression"
      type="DTS:PropertyExpressionElementType"
      minOccurs="0" maxOccurs="unbounded"/>
    <xs:element name="VariableValue">
      <xs:complexType mixed="true">
        <xs:sequence>
          <xs:any minOccurs="0" maxOccurs="unbounded"
            processContents="skip"/>
        </xs:sequence>
        <xs:attribute name="DataType" type="DTS:DtsDataTypeEnum"/>
        <xs:attribute name="DataSubType">
          <xs:simpleType>
            <xs:restriction base="xs:string">
              <xs:enumeration value="ManagedSerizlizable"/>
            </xs:restriction>
          </xs:simpleType>
        </xs:attribute>
      </xs:complexType>
    </xs:element>
  </xs:sequence>
  <xs:attributeGroup ref="DTS:BasePropertyAttributeGroup"/>
  <xs:attributeGroup ref="DTS:VariableAttributeGroup"/>
</xs:complexType>
```

The following table provides additional information about the elements, types, and constraints for the **VariableType** complex type.

Element	Additional constraints	Type definition	Description
PropertyExpression	Additional constraints exist for the PropertyExpression element. These constraints MUST be followed.	PropertyExpressionElementType	The PropertyExpression element serves the same purpose as specified for the Property element, except that an expression that is evaluated at run time is contained in the element's value that is stored in the Microsoft® SQL Server® Integration Services (SSIS) file format.
VariableValue	If the optional DataType attribute is included, the value of the element MUST be of the type that is specified by the DataType attribute. If the optional DataSubType attribute is included, the VariableValue element can contain complex content.		Contains the value that is used literally or is evaluated as an expression.

The following table provides additional information about the attributes, attribute groups, and types for the **VariableType** type.

Attribute	Description
BasePropertyAttributeGroup	An attribute group that specifies attributes that are common to many different types throughout the schema.
VariableAttributeGroup	An attribute group that specifies attributes for the VariableType type.

2.8.4.1.1 VariableAttributeGroup

The **VariableAttributeGroup** attribute group contains the attributes for the [VariableType](#) type.

The following is the XSD for the **VariableAttributeGroup** attribute group.

```
<xs:attributeGroup name="VariableAttributeGroup">
  <xs:attribute name="Namespace" type="xs:string" use="optional"
    default="" form="qualified"/>
  <xs:attribute name="Expression" type="xs:string" use="optional"
    default="" form="qualified"/>
  <xs:attribute name="EvaluateAsExpression" type="DTS:BooleanStringCap"
```

```

        use="optional" default="False" form="qualified"/>
<xs:attribute name="ReadOnly" type="DTS:BooleanStringCap" use="optional"
    default="False" form="qualified"/>
<xs:attribute name="RaiseChangedEvent" type="DTS:BooleanStringCap"
    use="optional" default="False" form="qualified"/>
<xs:attribute name="IncludeInDebugDump" type="xs:int" use="optional"
    default="0" form="qualified"/>
</xs:attributeGroup>

```

The following table specifies the attributes for the **VariableAttributeGroup** attribute group.

Attribute	Description
Namespace	A string value that specifies the namespace that the variable belongs to.
Expression	A string value that specifies the expression for the variable. This value is used only if the EvaluateAsExpression property is set to value "-1".
EvaluateAsExpression	A value of type DTS:BooleanStringCap that specifies whether the variable contains an expression. "True" specifies that the variable contains an expression. "False" specifies that the variable does not contain an expression.
ReadOnly	A value of type DTS:BooleanStringCap that specifies whether the variable is read-only. "True" specifies that the variable is read-only. "False" specifies that the variable is not read-only.
RaiseChangedEvent	A value of type DTS:BooleanStringCap that specifies whether the variable is flagged to raise the OnVariableValueChanged event when the variable's value changes. "True" specifies that the variable is flagged to have the OnVariableValueChanged event raised when the variable's value changes. "False" specifies that an OnVariableValueChanged event is not raised when the variable's value changes.
IncludeInDebugDump	An enumeration value that specifies whether the variable is included in a debug dump.

2.8.4.1.1.1 IncludeInDebugDumpEnum

The **IncludeInDebugDumpEnum** type contains the enumeration values that specify how whether the variable is included in a debug dump.

The following is the XSD of the **IncludeInDebugDumpEnum** type.

```

<xs:simpleType name="IncludeInDebugDumpEnum">
  <xs:restriction base="xs:int">
    <xs:enumeration value="2345"/>
    <xs:enumeration value="6789"/>
  </xs:restriction>
</xs:simpleType>

```

The following table specifies the descriptions for the enumeration values of the **IncludeInDebugDumpEnum** type.

Enumeration value	Description
2345	Specifies TRUE; the variable is included in debug dumps.
6789	Specifies FALSE; the variable is not included in debug dumps.

2.8.5 EventHandlersType

The **EventHandlersType** complex type is the container type for a collection of elements of type [EventHandlerType](#).

The following is the XSD of the **EventHandlersType** complex type.

```
<xs:complexType name="EventHandlersType">
  <xs:sequence>
    <xs:element name="EventHandler" type="DTS:EventHandlerType"
      minOccurs="0" maxOccurs="unbounded" form="qualified"/>
  </xs:sequence>
</xs:complexType>
```

The following table provides additional information about the elements, types, and constraints for the **EventHandlersType** complex type.

Element	Type definition	Description
EventHandler	EventHandlerType	Specifies an EventHandler element which in turn specifies the options, parameters, and settings for the event handler.

2.8.5.1 EventHandlerType

The **EventHandlerType** complex type is used to specify the triggering events and the executables that are executed when a specific event occurs during the execution of a container, task, or package.

```
<xs:complexType name="EventHandlerType">
  <xs:sequence>
    <xs:element name="PropertyExpression"
      type="DTS:PropertyExpressionElementType"
      minOccurs="0" maxOccurs="unbounded"/>
    <xs:element name="Variables" type="DTS:VariablesType" minOccurs="0"/>
    <xs:element name="LoggingOptions" type="DTS:LoggingOptionsType"/>
    <xs:element name="Executables" type="DTS:ExecutablesType" minOccurs="0"/>
    <xs:element name="PrecedenceConstraints"
      type="DTS:PrecedenceConstraintsType" minOccurs="0"/>
  </xs:sequence>
  <xs:attributeGroup ref="DTS:BasePropertyAttributeGroup"/>
  <xs:attributeGroup ref="DTS:BaseExecutablePropertyAttributeGroup"/>
  <xs:attributeGroup ref="DTS:EventHandlerAttributeGroup"/>
  <xs:attribute name="refId" type="xs:string" use="required"
    form="qualified"/>
</xs:complexType>
```

</xs:complexType>

The following is the XSD of the **EventHandlerType** complex type.

The following table provides additional information about the elements, types, and constraints for the **EventHandlerType** complex type.

Element	Constraints	Type definition	Description
Variables	None	VariablesType	Specifies a collection of definitions of variables that can be defined in the context of the event handler.
LoggingOptions	None	LoggingOptionsType	Specifies information about what kind of information is logged for this event handler and where that information is recorded.
PropertyExpression	Additional constraints exist for the PropertyExpression element.	PropertyExpressionElementType	Serves the same purpose as specified for the Property element, except that an expression that is evaluated at run time is contained in the element's value that is stored in the Microsoft® SQL Server® Integration Services (SSIS) file format.
Executables	None	ExecutablesType	Specifies a collection of executables that are executed when the event handler is fired.
PrecedenceConstraints	None	PrecedenceConstraintsType	Specifies a collection of precedence constraints between

Element	Constraints	Type definition	Description
			contained executables in this EventHandler element.

The following table provides additional information about the attributes, attribute groups, and types for the **EventHandlerType** complex type.

Attribute	Description
BasePropertyAttributeGroup	An attribute group that specifies attributes that are common to many different types throughout the schema.
BaseExecutablePropertyAttributeGroup	An attribute group that specifies attributes that are common to many different types throughout the schema.
EventHandlerAttributeGroup	An attribute group that specifies attributes for the EventHandlerType complex type.
refId	A string value that specifies a unique refId for this object. Elsewhere within the containing executable or within the package, the value of refId can be used to refer to this object. <103>

2.8.5.1.1 EventHandlerAttributeGroup

The **EventHandlerAttributeGroup** attribute group contains the attributes for the [EventHandlerType](#) type.

The following is the XSD for the **EventHandlerAttributeGroup** attribute group.

```
<xs:attributeGroup name="EventHandlerAttributeGroup">
  <xs:attribute name="EventID" type="xs:int" use="optional"
    default="0" form="qualified"/>
  <xs:attribute name="EventName" type="DTS:EventNameEnum"
    use="required" form="qualified"/>
</xs:attributeGroup>
```

The following table specifies the attributes for the **EventHandlerAttributeGroup** attribute group.

Attribute	Description
EventID	Specifies an integer that identifies this event. <104>
EventName	An enumeration value that specifies the name of the event that triggers this event handler.

2.8.5.1.1.1 EventNameEnum

The **EventNameEnum** type contains the enumeration values that specify the name of the event that will trigger the event handler.

The following is the XSD of the **EventNameEnum** type.

```
<xs:simpleType name="EventNameEnum">
  <xs:restriction base="xs:string">
    <xs:enumeration value="OnError"/>
    <xs:enumeration value="OnExecStatusChanged"/>
    <xs:enumeration value="OnInformation"/>
    <xs:enumeration value="OnPostExecute"/>
    <xs:enumeration value="OnPreExecute"/>
    <xs:enumeration value="OnPreValidate"/>
    <xs:enumeration value="OnProgress"/>
    <xs:enumeration value="OnQueryCancel"/>
    <xs:enumeration value="OnTaskFailed"/>
    <xs:enumeration value="OnVariableValueChanged"/>
    <xs:enumeration value="OnWarning"/>
    <xs:enumeration value="OnCustomEvent"/>
  </xs:restriction>
</xs:simpleType>
```

The following table specifies the descriptions for the enumeration values of the **EventNameEnum** type.

Enumeration value	Description
OnError	Specifies that the event is fired by an error condition.
OnExecStatusChanged	Specifies that the event is fired if execution status changes.
OnInformation	Specifies that the event is fired by availability of information.
OnPostExecute	Specifies that the event is fired after execution is complete.
OnPreExecute	Specifies that the event is fired before execution begins.
OnPreValidate	Specifies that the event is fired before validation begins.
OnProgress	Specifies that the event is fired when a progress status update is available.
OnQueryCancel	Specifies that the event is fired when a query is canceled.
OnTaskFailed	Specifies that the event is fired when a task fails.
OnVariableValueChanged	Specifies that the event is fired when a variable value changes.
OnWarning	Specifies that the event is fired if a warning condition is encountered.
OnCustomEvent	Specifies that the event is fired as defined by a custom event.

2.8.6 PrecedenceConstraintsType

The **PrecedenceConstraintsType** complex type is the container type for a collection of elements of type [PrecedenceConstraintType](#).

The following is the XSD of the **PrecedenceConstraintsType** complex type.

```

<xs:complexType name="PrecedenceConstraintsType">
  <xs:sequence>
    <xs:element name="PrecedenceConstraint"
      type="DTS:PrecedenceConstraintType"
      minOccurs="0" maxOccurs="unbounded"/>
  </xs:sequence>
</xs:complexType>

```

The following table provides additional information about the elements, types, and constraints for the **PrecedenceConstraintsType** complex type.

Element	Type definition	Description
PrecedenceConstraint	PrecedenceConstraintType	Specifies a precedence constraint that applies to the element that contains the collection.

2.8.6.1 PrecedenceConstraintType

The **PrecedenceConstraintType** complex type is used to specify an object that contains **precedence constraints** between the executable elements within a package.

The following is the XSD of the **PrecedenceConstraintType** complex type.

```

<xs:complexType name="PrecedenceConstraintType">
  <xs:sequence>
    <xs:element name="PropertyExpression"
      type="DTS:PropertyExpressionElementType"
      minOccurs="0" maxOccurs="unbounded"/>
  </xs:sequence>
  <xs:attributeGroup ref="DTS:BasePropertyAttributeGroup"/>
  <xs:attributeGroup ref="DTS:PrecedenceConstraintAttributeGroup"/>
  <xs:attribute name="refId" type="xs:string" use="required"
    form="qualified"/>
</xs:complexType>

```

The following table provides additional information about the elements, types, and constraints for the **PrecedenceConstraintType** complex type.

Element	Additional constraints	Type definition	Description
PropertyExpression	Additional constraints exist for the PropertyExpression element.	PropertyExpressionElementType	The PropertyExpression element serves the same purpose as specified for the Property element except that an expression that is evaluated at run time is contained in the element's value that is stored in the Microsoft® SQL

Element	Additional constraints	Type definition	Description
			Server® Integration Services (SSIS) file format.

The following table provides additional information about the attributes, attribute groups, and types for the **PrecedenceConstraintType** complex type.

Attribute	Description
BasePropertyAttributeGroup	An attribute group that specifies attributes that are common to many different types throughout the schema.
PrecedenceConstraintAttributeGroup	An attribute group that specifies attributes for the PrecedenceConstraintType complex type.
refId	A string value that specifies a unique refId for this object. Elsewhere within the containing executable or within the package, the value of refId can be used to refer to this object. <105>

2.8.6.1.1 PrecedenceConstraintAttributeGroup

The **PrecedenceConstraintAttributeGroup** attribute group contains the attributes for the [PrecedenceConstraintType](#) type.

The following is the XSD for the **PrecedenceConstraintAttributeGroup** attribute group.

```
<xs:attributeGroup name="PrecedenceConstraintAttributeGroup">
  <xs:attribute name="Value" type="DTS:PrecedenceConstraintValueEnum"
    use="optional" default="0" form="qualified"/>
  <xs:attribute name="EvalOp" type="DTS:PrecedenceConstraintEvalOpEnum"
    use="optional" default="1" form="qualified"/>
  <xs:attribute name="LogicalAnd" type="DTS:BooleanStringCap"
    use="optional" default="False" form="qualified"/>
  <xs:attribute name="Expression" type="xs:string" use="optional"
    default="" form="qualified"/>
  <xs:attribute name="From" type="xs:string" use="required"
    form="qualified"/>
  <xs:attribute name="To" type="xs:string" use="required"
    form="qualified"/>
</xs:attributeGroup>
```

The following table specifies the attributes for the **PrecedenceConstraintAttributeGroup** attribute group.

Attribute	Description
Value	An enumeration value that specifies the task completion status that is being checked for to determine precedence.
EvalOp	An enumeration value that specifies the type of evaluation operation for this PrecedenceConstraint instance.

Attribute	Description
LogicalAnd	A value of type DTS:BooleanStringCap that specifies whether to perform a logical AND operation on all the precedence constraints for an executable. "True" specifies that the precedence operation is a logical AND that includes all the precedence constraints for an executable. "False" specifies that the precedence operation is not a logical AND between all the precedence constraints for an executable.
Expression	A string value that specifies an expression to be evaluated.
From	A string value that specifies a refId attribute value on an Executable element in the package that is the origin end of the precedence constraint.
To	A string value that specifies a refId attribute value on a Executable element in the package that is the destination end of the precedence constraint.

2.8.6.1.1.1 PrecedenceConstraintEvalOpEnum

The **PrecedenceConstraintEvalOpEnum** type contains the enumeration values that specify the type of evaluation operation for the precedence constraint.

The following is the XSD of the **PrecedenceConstraintEvalOpEnum** type.

```
<xs:simpleType name="PrecedenceConstraintEvalOpEnum">
  <xs:restriction base="xs:int">
    <xs:minInclusive value="1"/>
    <xs:maxInclusive value="4"/>
  </xs:restriction>
</xs:simpleType>
```

The following table specifies the descriptions for the enumeration values of the **PrecedenceConstraintEvalOpEnum** type.

Enumeration value	Description
1	Specifies that the evaluation operation is based on an expression.
2	Specifies that the evaluation operation is based on a constraint.
3	Specifies that the evaluation operation is based on an expression and a constraint.
4	Specifies that the evaluation operation is based on an expression or a constraint.

2.8.6.1.1.2 PrecedenceConstraintValueEnum

The **PrecedenceConstraintValueEnum** type contains the enumeration values that specify the type of evaluation operation for the precedence constraint.

The following is the XSD of the **PrecedenceConstraintValueEnum** type.

```
<xs:simpleType name="PrecedenceConstraintValueEnum">
  <xs:restriction base="xs:int">
```

```

    <xs:minInclusive value="0"/>
    <xs:maxInclusive value="2"/>
  </xs:restriction>
</xs:simpleType>

```

The following table specifies the descriptions for the enumeration values of the **PrecedenceConstraintValueEnum** type.

Enumeration value	Description
0	The task completed with a return value of Success.
1	The task completed with a return value of Failure.
2	The task ran to completion.

2.9 Enumeration Types and Supporting Types

2.9.1 BasePropertyAttributeGroup

The **BasePropertyAttributeGroup** attribute group contains attributes that are used by many objects in the structure.

The following is the XSD for the **BasePropertyAttributeGroup** attribute group.

```

<xs:attributeGroup name="BasePropertyAttributeGroup">
  <xs:attribute name="Description" type="xs:string" default=""
    use="optional" form="qualified"/>
  <xs:attribute name="DTSID" type="DTS:uuid" use="required"
    form="qualified"/>
  <xs:attribute name="CreationName" type="xs:string" use="required"
    form="qualified"/>
  <xs:attribute name="ObjectName" type="xs:string" use="optional"
    form="qualified"/>
</xs:attributeGroup>

```

The following table specifies the attributes for the **BasePropertyAttributeGroup** attribute group.

Attribute	Description
Description	A string value that specifies a human-readable descriptive string. <106>
DTSID	A value of type DTS:uuid that specifies a unique identifier for this object. Elsewhere within the containing executable or within the package, the value of DTSID can be used to refer to this object. <107>
CreationName	A string value that specifies the CreationName for this object. <108>
ObjectName	A string value that specifies the ObjectName for this object. <109>

2.9.2 BaseExecutablePropertyAttributeGroup

The **BaseExecutablePropertyAttributeGroup** attribute group contains attributes that are used by executable objects in the structure.

The following is the XSD for the **BaseExecutablePropertyAttributeGroup** attribute group.

```
<xs:attributeGroup name="BaseExecutablePropertyAttributeGroup">
  <xs:attribute name="ForceExecValue" type="DTS:BooleanStringCap"
    default="False" use="optional" form="qualified"/>
  <xs:attribute name="ExecValue" type="xs:anySimpleType" default="0"
    use="optional" form="qualified"/>
  <xs:attribute name="ForceExecutionResult" default="-1" use="optional"
    type="DTS:ForceExecutionResultEnum" form="qualified"/>
  <xs:attribute name="Disabled" type="DTS:BooleanStringCap" default="False"
    use="optional" form="qualified"/>
  <xs:attribute name="FailPackageOnFailure" type="DTS:BooleanStringCap"
    default="False" use="optional" form="qualified"/>
  <xs:attribute name="FailParentOnFailure" type="DTS:BooleanStringCap"
    default="False" use="optional" form="qualified"/>
  <xs:attribute name="MaxErrorCount" type="xs:int" default="1"
    use="optional" form="qualified"/>
  <xs:attribute name="ISOLevel" type="DTS:ISOLevelEnum"
    default="1048576" use="optional" form="qualified"/>
  <xs:attribute name="LocaleID" type="xs:int" use="optional"
    form="qualified"/>
  <xs:attribute name="TransactionOption" type="DTS:TransactionOptionEnum"
    default="1" use="optional" form="qualified"/>
  <xs:attribute name="DelayValidation" type="DTS:BooleanStringCap"
    default="False" use="optional" form="qualified"/>
  <xs:attribute name="ExecValueType" type="DTS:DtsDataTypeEnum"
    use="required" form="qualified"/>
</xs:attributeGroup>
```

The following table specifies the attributes for the **BaseExecutablePropertyAttributeGroup** attribute group.

Attribute	Description
ForceExecValue	A value of type DTS:BooleanStringCap that specifies whether the Executable is forced to return a value regardless of the exit status of the executable. "False" specifies that the Executable is not forced to return a value regardless of the exit status. "True" specifies that the Executable is forced to return a value regardless of exit status.
ExecValue	A value of type xs:anySimpleType that specifies the value that is returned if the value of the ForceExecValue attribute is "True".
ForceExecutionResult	An enumeration value that specifies the return result that is returned if a result is forced to be returned, instead of the actual result.
Disabled	A value of type DTS:BooleanStringCap that specifies whether the executable is disabled and not available at run time. "True" specifies that the executable is disabled and not available at run time.

Attribute	Description
	"False" specifies that the executable is enabled.
FailPackageOnFailure	A value of type DTS:BooleanStringCap that specifies whether the package fails if this executable fails. "True" specifies that the package fails if the executable fails. "False" specifies that the package does not necessarily fail if the executable fails.
FailParentOnFailure	A value of type DTS:BooleanStringCap that specifies whether the parent of the containing Executable element fails if this executable fails. "True" specifies that the parent executable fails if this executable fails. "False" specifies that the parent executable does not necessarily fail if this executable fails.
MaxErrorCount	An integer value that specifies the maximum number of errors before the executable fails. If this count is reached or exceeded, the executable MUST fail.
ISOLevel	An enumeration value that specifies the isolation level for the executable.
LocaleID	An integer value that specifies the LCID for the language for this executable. <110>
TransactionOption	An enumeration value that specifies the transaction support and the transaction enrollment of the container.
DelayValidation	A value of type DTS:BooleanStringCap that specifies whether the validation of the executable is delayed until its container executes. "True" specifies that the validation of the executable is delayed until run time. "False" specifies that the validation of the executable is not delayed until run time.

2.9.2.1 ISOLevelEnum

The **ISOLevelEnum** type contains the enumeration values that specify isolation levels that can be specified.

The following is the XSD of the **ISOLevelEnum** type.

```
<xs:simpleType name="ISOLevelEnum">
  <xs:restriction base="xs:int">
    <xs:enumeration value="-1"/>
    <xs:enumeration value="16"/>
    <xs:enumeration value="1033"/>
    <xs:enumeration value="4096"/>
    <xs:enumeration value="65536"/>
    <xs:enumeration value="1048576"/>
    <xs:enumeration value="16777216"/>
  </xs:restriction>
</xs:simpleType>
```

The following table specifies the descriptions for the enumeration values of the **ISOLevelEnum** type.

Enumeration value	Type of isolation level
1048576	Serializable
16777216	Snapshot
65536	Repeatable Read
1033	Read Uncommitted
4096	Read Committed
16	Chaos
-1	Unspecified

2.9.2.2 TransactionOptionEnum

The **TransactionOptionEnum** type contains the enumeration values that specify transaction support options.

The following is the XSD of the **TransactionOptionEnum** type.

```
<xs:simpleType name="TransactionOptionEnum">
  <xs:restriction base="xs:int">
    <xs:minInclusive value="0"/>
    <xs:maxInclusive value="2"/>
  </xs:restriction>
</xs:simpleType>
```

The following table specifies the descriptions for the enumeration values of the **TransactionOptionEnum** type.

Enumeration value	Support for transactions indicated
0	Not supported
1	Supported
2	Required

2.9.2.3 ForceExecutionResultEnum

The **ForceExecutionResultEnum** type contains the enumeration values that specify the result values that can be specified to be returned, instead of the actual result value, when a value's return is forced.

The following is the XSD of the **ForceExecutionResultEnum** type.

```
<xs:simpleType name="ForceExecutionResultEnum">
  <xs:restriction base="xs:int">
    <xs:minInclusive value="-1"/>
    <xs:maxInclusive value="2"/>
  </xs:restriction>
</xs:simpleType>
```

```

    </xs:restriction>
  </xs:simpleType>

```

The following table specifies the descriptions for the enumeration values of the **ForceExecutionResultEnum** type.

Enumeration value	Execution result that is forced
-1	None
0	Success
1	Failure
2	Completion

2.9.3 AllExecutableAttributeGroup

The **AllExecutableAttributeGroup** attribute group contains attributes that are used by all executable objects in the structure.

The following is the XSD for the **AllExecutableAttributeGroup** attribute group.

```

<xs:attributeGroup name="AllExecutableAttributeGroup">
  <xs:attribute name="DisableEventHandlers" type="DTS:BooleanStringCap"
    default="False" use="optional" form="qualified"/>
</xs:attributeGroup>

```

The following table specifies the attributes for the **AllExecutableAttributeGroup** attribute group.

Attribute	Description
DisableEventHandlers	<p>A value of type DTS:BooleanStringCap that specifies whether event handlers for this executable are disabled.</p> <p>"True" specifies that any event handlers applied to this executable are disabled.</p> <p>"False" specifies that event handlers applied to this executable are not disabled.</p>

2.9.4 BooleanStringCap

The **BooleanStringCap** type contains string enumeration values that are used to act as a Boolean value and to express a true or false state. The **BooleanStringCap** type is referenced by other types in the Microsoft® SQL Server® Integration Services (SSIS) package file format.

The following is the XSD for the **BooleanStringCap** type.

```

<xs:simpleType name="BooleanStringCap">
  <xs:restriction base="xs:string">
    <xs:enumeration value="True"/>
    <xs:enumeration value="False"/>
  </xs:restriction>
</xs:simpleType>

```

```
</xs:simpleType>
```

The following table specifies the enumeration values for the **BooleanStringCap** type.

Enumeration value	Description
False	Specifies that the setting is False.
True	Specifies that the setting is True.

2.9.5 UUID

The **UUID** type is used to specify the text pattern for references to DTSID values.

The following is the XSD of the **UUID** type.

```
<xs:simpleType name="uuid">
  <xs:restriction base="xs:string">
    <xs:pattern value="\{[0-9a-zA-Z]{8}-[0-9a-zA-Z]{4}-[0-9a-zA-Z]{4}-[0-9a-
zA-Z]{12}\}" />
  </xs:restriction>
</xs:simpleType>
```

2.9.6 PasswordElementType

The **PasswordElementType** complex type specifies the type of the **Password** element that is a child element of other elements within the Microsoft® SQL Server® Integration Services (SSIS) package file format. The **PasswordElementType** type is used to store the password information for connecting to a data source.

The following is the XSD of the **PasswordElementType** complex type.

```
<xs:complexType name="PasswordElementType">
  <xs:simpleContent>
    <xs:extension base="xs:string">
      <xs:attribute name="Sensitive" form="unqualified">
        <xs:simpleType>
          <xs:restriction base="xs:int">
            <xs:minInclusive value="0"/>
            <xs:maxInclusive value="1"/>
          </xs:restriction>
        </xs:simpleType>
      </xs:attribute>
      <xs:attribute name="Encrypted" form="unqualified">
        <xs:simpleType>
          <xs:restriction base="xs:int">
            <xs:minInclusive value="0"/>
            <xs:maxInclusive value="1"/>
          </xs:restriction>
        </xs:simpleType>
      </xs:attribute>
    </xs:extension>
  </xs:simpleContent>
```



```
</xs:complexType>
```

The **PasswordElementType** complex type MUST NOT contain any elements.

The following table specifies the attributes for the **PasswordElementType** complex type.

Attribute	Description
Sensitive	Specifies that the element value contains an indicator for whether the password information is treated as sensitive. The integer value has the following interpretations: 0 = FALSE; the password is not considered to be sensitive. 1 = TRUE; the password is considered to be sensitive.
Encrypted	Specifies that the element value contains an indicator for whether the element value is encrypted. The integer value has the following interpretations: 0 = FALSE; the element value is not encrypted. 1 = TRUE; the element value is encrypted.

2.9.7 SourceTypeEnum

The **SourceTypeEnum** type contains enumeration values that are used to specify the type of an input source. The **SourceTypeEnum** type is referenced by other types in the Microsoft® SQL Server® Integration Services (SSIS) package file format.

The following is the XSD for the **SourceTypeEnum** type.

```
<xs:simpleType name="SqlStmtSourceTypeEnum">  
  <xs:restriction base="xs:string">  
    <xs:enumeration value="DirectInput"/>  
    <xs:enumeration value="FileConnection"/>  
    <xs:enumeration value="Variable"/>  
  </xs:restriction>  
</xs:simpleType>
```

The following table specifies the enumeration values for the **SourceTypeEnum** type.

Enumeration value	Description
DirectInput	Specifies that the source text is contained inline in a package file as the value of another element.
FileConnection	Specifies that the source text is contained in a file connection.
Variable	Specifies that the source text is contained in a variable.

2.9.8 DestinationTypeEnum

The **DestinationTypeEnum** type contains enumeration values that are used to specify the type of a destination source. The **DestinationTypeEnum** type is referenced by other types in the Microsoft® SQL Server® Integration Services (SSIS) package file format.

The following is the XSD of the **DestinationTypeEnum** type.

```
<xs:simpleType name="DestinationTypeEnum">
  <xs:restriction base="xs:string">
    <xs:enumeration value="FileConnection"/>
    <xs:enumeration value="Variable"/>
  </xs:restriction>
</xs:simpleType>
```

The following table specifies the enumeration values for the **DestinationTypeEnum** type.

Enumeration value	Description
FileConnection	Specifies that the source is contained in a file connection.
Variable	Specifies that the source is contained in a variable.

2.9.9 IfObjectExistsEnum

The **IfObjectExistsEnum** type contains the enumeration values for the **IfObjectExists** attribute.

The following is the XSD of the **IfObjectExistsEnum** type.

```
<xs:simpleType name="IfObjectExistsEnum">
  <xs:restriction base="xs:string">
    <xs:enumeration value="FailTask"/>
    <xs:enumeration value="Overwrite"/>
    <xs:enumeration value="Skip"/>
  </xs:restriction>
</xs:simpleType>
```

The following table specifies the enumeration values for the **IfObjectExistsEnum** type.

Enumeration value	Description
FailTask	Specifies that the task MUST fail if the object exists at the destination for the transfer.
Overwrite	Specifies that the task MUST overwrite the previously existing object if the object exists at the destination for the transfer.
Skip	Specifies that the task MUST skip the transfer of such objects if the object exists at the destination for the transfer.

2.9.10 InnerObjectObjectType

The **InnerObjectObjectType** complex type specifies a type that can contain any element. It is used for extending and customizing [Executable](#) elements and **LogProvider** elements.

The following is the XSD of the **InnerObjectObjectType** complex type.

```

<xs:complexType name="InnerObjectObjectDataType">
  <xs:sequence>
    <xs:any minOccurs="0" maxOccurs="unbounded"
      namespace="##any" processContents="skip"/>
  </xs:sequence>
</xs:complexType>

```

The **InnerObjectObjectDataType** type MAY contain any element in any namespace. [<111>](#)

2.9.11 DesignTimeProperties String Value XML Content

The **DesignTimeProperties** element is of type **xs:string**. The contents of the string value MUST form a valid XML document with an **Objects** root node. This section specifies the XML for the **Objects** node, specified as XSD definitions. However, none of these elements appear as XML elements within a package file, as they appear only within the string value for the **DesignTimeProperties** element.

Where elements within the **DesignTimeProperties** string value refer to elements in a namespace, this is documented. All other elements are in an unspecified namespace.

2.9.11.1 Objects Element

The declaration for the **Objects** element, the root node of the [DesignTimeProperties](#) string value, is as follows.

```

<xs:element name="Objects" type="ObjectsType"/>

```

2.9.11.1.1 ObjectsType

The **ObjectsType** complex type specifies the screen layout of a package diagram.

The following is the XSD for the **ObjectsType** complex type.

```

<xs:complexType name="ObjectsType">
  <xs:sequence>
    <xs:element name="Package"
      type="DTS:DesignTimePropertiesContainerType"/>
    <xs:element name="TaskHost"
      type="DTS:DesignTimePropertiesContainerType" minOccurs="0"/>
    <xs:element name="DtsEventHandler"
      type="DTS:DesignTimePropertiesContainerType"
      minOccurs="0" maxOccurs="unbounded"/>
  </xs:sequence>
  <xs:attribute name="Version" type="xs:string"/>
</xs:complexType>

```

The following table provides additional information about the elements for the **ObjectsType** complex type.

Element	Description
Package	A complex type that specifies the screen layout of a package.
TaskHost	A complex type that specifies the screen layout of the tasks within a package.
DtsEventHandler	A complex type that specifies the screen layout of event handlers within a package.

The following table provides additional information about the attributes for the **ObjectsType** complex type.

Attribute	Description
Version	A string value that specifies information about the product version that the described objects correspond to.

2.9.11.1.1.1 DesignTimePropertiesContainerType

The **DesignTimePropertiesContainerType** complex type specifies the screen layout of one of several individual object types used to diagram a package.

The following is the XSD for the **DesignTimePropertiesContainerType** complex type.

```
<xs:complexType name="DesignTimePropertiesContainerType">
  <xs:sequence>
    <xs:element name="LayoutInfo" type="LayoutInfoType"/>
  </xs:sequence>
  <xs:attribute name="design-time-name" type="xs:string"/>
</xs:complexType>
```

The following table provides additional information about the elements for the **DesignTimePropertiesContainerType** complex type.

Element	Description
LayoutInfo	A complex type that specifies screen layout information for each object.

The following table provides additional information about the attributes for the **DesignTimePropertiesContainerType** complex type.

Attribute	Description
design-time-name	A string value that specifies a symbolic name that is used to identify the object.

2.9.11.1.1.1.1 LayoutInfoType

The **LayoutInfoType** complex type specifies the screen layout of an individual object from a session of using the SSIS Designer user interface.

The following is the XSD for the **LayoutInfoType** complex type.

```

<xs:complexType name="LayoutInfoType">
  <xs:sequence>
    <xs:element ref="is-ser:GraphLayout" maxOccurs="unbounded"/>
  </xs:sequence>
</xs:complexType>

```

The following table provides additional information about the elements for the **LayoutInfoType** complex type.

Element	Description
is-ser:GraphLayout	A complex type that specifies the screen layout of an object.

The **LayoutInfoType** complex type MUST NOT have attributes.

2.9.11.1.1.1.1.1 is-ser Namespace

The namespace that is identified by the **is-ser** prefix is defined as follows.

```

xmlns:is-ser=
"clr-namespace:Microsoft.SqlServer.IntegrationServices.Designer.
Model.Serialization;assembly=Microsoft.SqlServer.
IntegrationServices.Graph"

```

2.9.11.1.1.1.1.2 is-ser:GraphLayout Element

The **is-ser:GraphLayout** element is defined as follows.

```

<xs:element name="GraphLayout" type="is-ser:GraphLayoutType"/>

```

2.9.11.1.1.1.1.3 GraphLayoutType

The **GraphLayoutType** complex type specifies the layout graph of the objects that describe a package.

The following is the XSD for the **GraphLayoutType** complex type.

```

<xs:complexType name="GraphLayoutType">
  <xs:sequence>
    <xs:element name="NodeLayout" type="is-ser:NodeLayoutType"
      maxOccurs="unbounded" minOccurs="0"/>
    <xs:element name="EdgeLayout" type="is-ser:EdgeLayoutType"
      maxOccurs="unbounded" minOccurs="0"/>
    <xs:element name="ContainerLayout" type="is-ser:ContainerLayoutType"
      maxOccurs="unbounded" minOccurs="0"/>
    <xs:element name="AnnotationLayout" type="is-ser:AnnotationLayoutType"
      maxOccurs="unbounded" minOccurs="0"/>
  </xs:sequence>
  <xs:attribute name="Capacity" type="xs:int"/>
</xs:complexType>

```

The following table provides additional information about the elements for the **GraphLayoutType** complex type.

Element	Description
NodeLayout	A complex type that specifies the screen layout of a graph node.
EdgeLayout	A complex type that specifies the screen layout of an edge.
ContainerLayout	A complex type that specifies the screen layout of a container.
AnnotationLayout	A complex type that specifies the screen layout of an annotation.

The following table provides additional information about the attributes for the **GraphLayoutType** complex type.

Attribute	Description
Capacity	An integer value that specifies the maximum number of contained elements that can be held without resizing the structure.

2.9.11.1.1.1.1.3.1 NodeLayoutType

The **NodeLayoutType** complex type specifies the screen layout of an individual node of a package.

The following is the XSD for the **NodeLayoutType** complex type.

```
<xs:complexType name="NodeLayoutType">
  <xs:sequence/>
  <xs:attribute name="Size" type="xs:string"/>
  <xs:attribute name="Id" type="xs:string"/>
  <xs:attribute name="TopLeft" type="xs:string"/>
</xs:complexType>
```

The **NodeLayoutType** complex type contains no elements.

The following table provides additional information about the attributes for the **NodeLayoutType** complex type.

Attribute	Description
Size	A string value that specifies the size of the node, in WPF units .
Id	A string value that specifies an identifier for the node.
TopLeft	A string value that specifies the coordinates of the top-left corner of the node, in WPF units.

2.9.11.1.1.1.1.3.2 EdgeLayoutType

The **EdgeLayoutType** complex type specifies the screen layout of an edge within a package layout diagram.

The following is the XSD for the **EdgeLayoutType** complex type.

```

<xs:complexType name="EdgeLayoutType">
  <xs:sequence>
    <xs:element name="EdgeLayout.Curve"
      type="is-ser:EdgeLayoutCurveType" />
    <xs:element name="EdgeLayout.Labels"
      type="is-ser:EdgeLayoutLabelsType" />
  </xs:sequence>
  <xs:attribute name="Id" type="xs:string"/>
  <xs:attribute name="TopLeft" type="xs:string"/>
</xs:complexType>

```

The following table provides additional information about the elements for the **EdgeLayoutType** complex type.

Element	Description
EdgeLayout.Curve	A complex type that describes the layout of the curve associated with an edge.
EdgeLayout.Labels	A complex type that describes the layout of the labels associated with an edge.

The following table provides additional information about the attributes for the **EdgeLayoutType** complex type.

Attribute	Description
Id	A string value that specifies an identifier for the edge.
TopLeft	A string value that specifies the top-left coordinate of the edge, in WPF units.

2.9.11.1.1.1.1.3.3 EdgeLayoutCurveType

The **EdgeLayoutCurveType** complex type specifies the screen layout of a curve that is part of a package representation.

The following is the XSD for the **EdgeLayoutCurveType** complex type.

```

<xs:complexType name="EdgeLayoutCurveType">
  <xs:sequence>
    <xs:element ref="mssggle:Curve"/>
  </xs:sequence>
  <xs:attribute name="Id" type="xs:string"/>
  <xs:attribute name="TopLeft" type="xs:string"/>
</xs:complexType>

```

The following table provides additional information about the elements for the **EdgeLayoutCurveType** complex type.

Element	Description
mssggle:Curve	A complex type defined in the namespace referenced by the mssggle prefix that specifies the segments of the curve.

The following table provides additional information about the attributes for the **EdgeLayoutCurveType** complex type.

Attribute	Description
Id	A string value that specifies an identifier for the curve.
TopLeft	A string value that specifies the top-left coordinate of the curve, in WPF units.

2.9.11.1.1.1.1.3.4 mssggle Namespace

The namespace identified by the **mssggle** prefix is defined as follows.

```
xmlns:mssggle="clr-namespace:Microsoft.SqlServer.Graph.LayoutEngine;
assembly=Microsoft.SqlServer.Graph"
```

2.9.11.1.1.1.1.3.5 mssggle:Curve Element

The **mssggle:Curve** element is defined as follows.

```
<xs:element name="Curve" type="mssggle:CurveType"/>
```

2.9.11.1.1.1.1.3.6 CurveType

The **CurveType** complex type specifies the screen layout of a curve that is part of a package representation.

The following is the XSD for the **CurveType** complex type.

```
<xs:complexType name="CurveType">
  <xs:sequence>
    <xs:element name="Curve.Segments" type="mssggle:CurveSegmentsType" />
  </xs:sequence>
  <xs:attribute name="StartConnector" type="xs:string"/>
  <xs:attribute name="EndConnector" type="xs:string"/>
  <xs:attribute name="Start" type="xs:string"/>
  <xs:attribute name="End" type="xs:string"/>
</xs:complexType>
```

The following table provides additional information about the elements for the **CurveType** complex type.

Element	Description
Curve.Segments	A complex type defined in the namespace referenced by the mssggle prefix that specifies an individual segment of the curve.

The following table provides additional information about the attributes for the **CurveType** complex type.

Attribute	Description
StartConnector	A string value that specifies the coordinates of the start point of the start connector for the curve, in WPF units.
EndConnector	A string value that specifies the coordinates of the end point of the end connector for the curve, in WPF units.
Start	A string value that specifies the coordinates of the start point of the curve, in WPF units.
End	A string value that specifies the coordinates of the end point of the curve, in WPF units.

2.9.11.1.1.1.1.3.7 CurveSegmentsType

The **CurveSegmentsType** complex type specifies a collection of segments of a curve as laid out on the screen.

The following is the XSD for the **CurveSegmentsType** complex type.

```
<xs:complexType name="CurveSegmentsType">
  <xs:sequence>
    <xs:element name="SegmentCollection"
      type="mssggle:SegmentCollectionType"/>
  </xs:sequence>
</xs:complexType>
```

The following table provides additional information about the elements for the **CurveSegmentsType** complex type.

Element	Description
SegmentCollection	A complex type that specifies the collection of segments that form a curve.

The **CurveSegmentsType** complex type has no attributes.

2.9.11.1.1.1.1.3.8 SegmentCollectionType

The **SegmentCollectionType** complex type specifies an individual segment of a curve.

The following is the XSD for the **SegmentCollectionType** complex type.

```
<xs:complexType name="SegmentCollectionType">
  <xs:sequence>
    <xs:element name="LineSegment" type="mssggle:LineSegmentType"
      minOccurs="0" maxOccurs="unbounded"/>
    <xs:element name="CubicBezierSegment"
      type="mssggle:CubicBezierSegmentType"
      minOccurs="0" maxOccurs="unbounded"/>
  </xs:sequence>
  <xs:attribute name="Capacity" type="xs:int"/>
</xs:complexType>
```

```
</xs:complexType>
```

The following table provides additional information about the elements for the **SegmentCollectionType** complex type.

Element	Description
LineSegment	A complex type that specifies a line segment.
CubicBezierSegment	A complex type that specifies a cubic Bezier curve segment.

The following table provides additional information about the attributes for the **SegmentCollectionType** complex type.

Attribute	Description
Capacity	An integer value that specifies the maximum number of contained elements that can be held without resizing the structure.

2.9.11.1.1.1.3.9 LineSegmentType

The **LineSegmentType** complex type specifies an individual line segment of a curve.

The following is the XSD for the **LineSegmentType** complex type.

```
<xs:complexType name="LineSegmentType">
  <xs:sequence/>
  <xs:attribute name="End" type="xs:string"/>
</xs:complexType>
```

The **LineSegmentType** complex type contains no elements.

The following table provides additional information about the attributes for the **LineSegmentType** complex type.

Attribute	Description
End	A string value that specifies the coordinates, in WPF units, of the end of the line segment.

2.9.11.1.1.1.3.10 CubicBezierSegmentType

The **CubicBezierSegmentType** complex type specifies a cubic Bezier segment of a curve.

The following is the XSD for the **CubicBezierSegmentType** complex type.

```
<xs:complexType name="CubicBezierSegmentType">
  <xs:sequence/>
  <xs:attribute name="Point1" type="xs:string"/>
  <xs:attribute name="Point2" type="xs:string"/>
  <xs:attribute name="Point3" type="xs:string"/>
</xs:complexType>
```

```
</xs:complexType>
```

The **CubicBezierSegmentType** complex type contains no elements.

The following table provides additional information about the attributes for the **CubicBezierSegmentType** complex type.

Attribute	Description
Point1	A string value that specifies the coordinates, in WPF units, of the first point of the cubic Bezier cube segment.
Point2	A string value that specifies the coordinates, in WPF units, of the second point of the cubic Bezier cube segment.
Point3	A string value that specifies the coordinates, in WPF units, of the third point of the cubic Bezier cube segment.

2.9.11.1.1.1.3.11 EdgeLayoutLabelsType

The **EdgeLayoutLabelsType** complex type specifies a collection of edge layout labels of a curve as laid out on the screen.

The following is the XSD for the **EdgeLayoutLabelsType** complex type.

```
<xs:complexType name="EdgeLayoutLabelsType">  
  <xs:sequence>  
    <xs:element name="EdgeLabelCollection"  
      type="is-ser:EdgeLabelCollectionType"  
      minOccurs="0"/>  
    <xs:element ref="mssgm:EdgeLabel" minOccurs="0"  
      maxOccurs="unbounded"/>  
  </xs:sequence>  
</xs:complexType>
```

The following table provides additional information about the elements for the **EdgeLayoutLabelsType** complex type.

Element	Description
EdgeLabelCollection	A complex type that specifies a collection of edge labels.
EdgeLabel	A complex type that specifies an individual edge label.

The **EdgeLayoutLabelsType** complex type has no attributes.

2.9.11.1.1.1.3.12 EdgeLabelCollectionType

The **EdgeLabelCollectionType** complex type specifies a collection of a package as viewed on the screen.

The following is the XSD for the **EdgeLabelCollectionType** complex type.

```
<xs:complexType name="EdgeLabelCollectionType">
  <xs:sequence/>
</xs:complexType>
```

The **EdgeLabelCollectionType** complex type has no elements.

The **EdgeLabelCollectionType** complex type has no attributes.

2.9.11.1.1.1.3.13 mssgm Namespace

The namespace identified by the **mssgm** prefix is defined as follows.

```
xmlns:mssgm="clr-namespace:Microsoft.SqlServer.Graph.Model;
assembly=Microsoft.SqlServer.Graph"
```

2.9.11.1.1.1.3.14 mssgm:EdgeLabel Element

The **mssgm:EdgeLabel** element is defined as follows.

```
<xs:element name="EdgeLabel" type="mssgm:EdgeLabelType"/>
```

2.9.11.1.1.1.3.15 EdgeLabelType

The **EdgeLabelType** complex type specifies an edge label that is part of the screen representation of a package.

The following is the XSD for the **EdgeLabelType** complex type.

```
<xs:complexType name="EdgeLabelType">
  <xs:sequence/>
  <xs:attribute name="BoundingBox" type="xs:string"/>
  <xs:attribute name="RelativePosition"
    type="mssgm:RelativePositionEnum"/>
</xs:complexType>
```

The **EdgeLabelType** complex type contains no elements.

The following table provides additional information about the attributes for the **EdgeLabelType** complex type.

Attribute	Description
BoundingBox	A string value that specifies the coordinates of the four vertices of the bounding box for the edge label, in WPF units.
RelativePosition	An enumeration value that specifies the relative position of the edge label.

2.9.11.1.1.1.3.16 RelativePositionEnum

The **RelativePositionEnum** type contains the enumeration values that specify the allowed relative position values.

The following is the XSD of the **RelativePositionEnum** type.

```
<xs:simpleType name="RelativePositionEnum">
  <xs:restriction base="xs:string">
    <xs:enumeration value="Any"/>
  </xs:restriction>
</xs:simpleType>
```

The following table specifies the descriptions for the enumeration values of the **RelativePositionEnum** type.

Enumeration value	Description
Any	The configuration is retrieved from any relative position.

2.9.11.1.1.1.3.17 ContainerLayoutType

The **ContainerLayoutType** complex type specifies the screen layout of a container within a package description.

The following is the XSD for the **ContainerLayoutType** complex type.

```
<xs:complexType name="ContainerLayoutType">
  <xs:sequence/>
  <xs:attribute name="Size" type="xs:string"/>
  <xs:attribute name="Id" type="xs:string"/>
  <xs:attribute name="TopLeft" type="xs:string"/>
  <xs:attribute name="HeaderHeight" type="xs:double"/>
  <xs:attribute name="IsExpanded" type="DTS:BooleanStringCap"/>
  <xs:attribute name="PanelSize" type="xs:string"/>
</xs:complexType>
```

The **ContainerLayoutType** complex type contains no elements.

The following table provides additional information about the attributes for the **ContainerLayoutType** complex type.

Attribute	Description
Size	A string value that specifies the size of the container, in WPF units.
Id	A string value that specifies an identifier for the container.
TopLeft	A string value that specifies the coordinates of the top-left corner of the container, in WPF units.
HeaderHeight	A value of type xs:double that specifies the height of the container header, in WPF units.

Attribute	Description
IsExpanded	A value of type DTS:BooleanStringCap that specifies whether the container is expanded or collapsed. "True" specifies that the container is expanded. "False" specifies that the container is collapsed.
PanelSize	A string value that specifies the panel size, in WPF units.

2.9.11.1.1.1.3.18 AnnotationLayoutType

The **AnnotationLayoutType** complex type specifies the screen layout of an annotation that can be added to a package file layout.

The following is the XSD for the **AnnotationLayoutType** complex type.

```
<xs:complexType name="AnnotationLayoutType">
  <xs:sequence>
    <xs:element name="AnnotationLayout.FontInfo"
      type="is-ser:AnnotationLayoutFontInfoType"
      minOccurs="0"/>
  </xs:sequence>
  <xs:attribute name="ParentId" type="xs:string"/>
  <xs:attribute name="Text" type="xs:string"/>
  <xs:attribute name="Size" type="xs:string"/>
  <xs:attribute name="TopLeft" type="xs:string"/>
  <xs:attribute name="Id" type="xs:int"/>
</xs:complexType>
```

The following table provides additional information about the elements for the **AnnotationLayoutType** complex type.

Element	Description
AnnotationLayout.FontInfo	A complex type that specifies information about the fonts used on the screen for an annotation.

The following table provides additional information about the attributes for the **AnnotationLayoutType** complex type.

Attribute	Description
ParentId	A string value that specifies the Id attribute value for the parent of this annotation.
Text	A string value that specifies the text of the annotation.
Size	A string value that specifies the size of the annotation, in WPF units.
TopLeft	A string value that specifies the top left coordinates of the annotation, in WPF units.
Id	A string value that specifies an identifier for this annotation.

2.9.11.1.1.1.3.19 AnnotationLayoutFontInfoType

The **AnnotationLayoutFontInfoType** complex type specifies the fonts for an annotation to a package file.

The following is the XSD for the **AnnotationLayoutFontInfoType** complex type.

```
<xs:complexType name="AnnotationLayoutFontInfoType">
  <xs:sequence>
    <xs:element ref="mssge:FontInfo"/>
  </xs:sequence>
</xs:complexType>
```

The following table provides additional information about the elements for the **AnnotationLayoutFontInfoType** complex type.

Element	Description
FontInfo	A complex type that specifies information about the fonts used on the screen for an annotation. The FontInfo element is in the namespace designated by the prefix mssge .

The **AnnotationLayoutFontInfoType** complex type has no attributes.

2.9.11.1.1.1.3.20 mssge Namespace

The namespace identified by the **mssge** prefix is defined as follows.

```
xmlns:mssge="clr-namespace:Microsoft.SqlServer.Graph.Extended;
assembly=Microsoft.SqlServer.IntegrationServices.Graph"
```

2.9.11.1.1.1.3.21 mssge:FontInfo Element

The **mssge:FontInfo** element is defined as follows.

```
<xs:element name="FontInfo" type="mssge:FontInfo"/>
```

2.9.11.1.1.1.3.22 FontInfoType

The **FontInfoType** complex type specifies the information about fonts as they appear on the screen.

The following is the XSD for the **FontInfoType** complex type.

```
<xs:complexType name="FontInfo">
  <xs:sequence>
    <xs:element name="FontInfo.TextDecorations"
      type="mssge:FontInfoTextDecorationsType"/>
  </xs:sequence>
  <xs:attribute name="Family" type="xs:string"/>
</xs:complexType>
```

```

<xs:attribute name="Size" type="xs:int"/>
<xs:attribute name="Color" type="xs:string"/>
<xs:attribute name="Style" type="xs:string"/>
<xs:attribute name="Weight" type="xs:string"/>
</xs:complexType>

```

The following table provides additional information about the elements for the **EdgeLayoutType** complex type.

Element	Description
FontInfo.TextDecorations	A complex type that specifies information about the text decorations added to a font.

The following table provides additional information about the attributes for the **FontInfoType** complex type.

Attribute	Description
Family	A string value that specifies the name of the font family.
Size	An integer value that specifies the size of the font.
Color	A string value that specifies the color of the font. The string value is the color value in hexadecimal; the prefix of this color value is the number sign (#) character.
Style	A string value that specifies the style for the font.
Weight	A string value that specifies the weight of the font.

2.9.11.1.1.1.3.23 FontInfoTextDecorationsType

The **FontInfoTextDecorationsType** complex type specifies information about the text decorations that are added to a font.

The following is the XSD for the **FontInfoTextDecorationsType** complex type.

```

<xs:complexType name="FontInfoTextDecorationsType">
  <xs:sequence>
    <xs:element ref="av:TextDecorationCollection"/>
  </xs:sequence>
</xs:complexType>

```

The following table provides additional information about the elements for the **FontInfoTextDecorationsType** complex type.

Element	Description
TextDecorationsCollection	A complex type that specifies information about the decorations that are added to the fonts used on the screen. The TextDecorationsCollection element is in the namespace that is designated by the prefix av .

The **FontInfoTextDecorationsType** complex type has no attributes.

2.9.11.1.1.1.1.3.24 av Namespace

The namespace identified by the **av** prefix is defined as follows.

```
xmlns:av="http://schemas.microsoft.com/winfx/2006/xaml/presentation"
```

2.9.11.1.1.1.1.3.25 av:TextDecorationsCollection Element

The **av:TextDecorationsCollection** element is defined as follows.

```
<xs:element name="TextDecorationCollection"  
            type="av:TextDecorationCollectionType"/>
```

2.9.11.1.1.1.1.3.26 TextDecorationCollectionType

The **TextDecorationCollectionType** complex type specifies a text decoration for text that is part of the representation of a package file.

The following is the XSD for the **TextDecorationCollectionType** complex type.

```
<xs:complexType name="TextDecorationCollectionType">  
  <xs:sequence>  
    <xs:element name="TextDecoration" type="av:TextDecorationType"  
                minOccurs="0" maxOccurs="unbounded"/>  
  </xs:sequence>  
</xs:complexType>
```

The following table provides additional information about the elements for the **TextDecorationCollectionType** complex type.

Element	Description
TextDecoration	A complex type that specifies information for a specific text decoration for a font.

The **TextDecorationCollectionType** complex type has no attributes.

2.9.11.1.1.1.1.3.27 TextDecorationType

The **TextDecorationType** complex type specifies information for a specific text decoration for a font.

The following is the XSD for the **TextDecorationType** complex type.

```
<xs:complexType name="TextDecorationType">  
  <xs:sequence/>  
  <xs:attribute name="Location" type="xs:string"/>  
</xs:complexType>
```

The **TextDecorationType** complex type has no elements.

The following table provides additional information about the attributes for the **TextDecorationType** complex type.

Attribute	Description
Location	A string value that specifies the location of the text decoration.

2.10 Custom Packages

Microsoft® SQL Server® Integration Services (SSIS) allows users to create custom packages that execute new objects beyond the objects that ship with the standard Integration Services system. These packages are described by the XSD in section 2 of this document. Users can create the following custom objects:

- Executable
- ConnectionManager
- Log provider
- ForEach Enumerator
- Components

The following sections describe these custom objects and their impact on the XSD of the DTSX structure format.

Note For more information about the environment for the development of custom package objects, see [\[MSDN-EPCO\]](#).

2.10.1 Custom Executable

Software developers can author a custom executable by using a software development environment and a programming language. These custom executables can then be executed as part of an Microsoft® SQL Server® Integration Services (SSIS) package. When a custom executable is authored, the XSD for the Integration Services format structure can change in the following ways:

- The **ExecutableType** attribute is no longer limited to the enumerated list as defined by the [AnyNonPackageExecutableTypeExecutableTypeEnum](#) type.
- The **ObjectData** element of the executable can contain any XML that the executable author defines to support the authored executable.

The following sections explain the impact on the XSD for custom executables.

2.10.1.1 AnyNonPackageExecutableTypeExecutableTypeEnum Type Replacement

In the case of custom packages, the definition of the [AnyNonPackageExecutableTypeExecutableTypeEnum](#) type is replaced with the following XSD definition for the **AnyNonPackageExecutableTypeExecutableTypeEnumCustom** type, and all references to the **AnyNonPackageExecutableTypeExecutableTypeEnum** type are replaced by references to the **AnyNonPackageExecutableTypeExecutableTypeEnumCustom** type. Now, any string is permitted to be added to the enumeration. The string that is used for the enumeration

extension MUST be the strong name of the Microsoft® .NET Framework assembly that contains the compiled executable code.

The following is the XSD for the **AnyNonPackageExecutableTypeExecutableTypeEnumCustom** type.

```
<xs:simpleType
  name="AnyNonPackageExecutableTypeExecutableTypeEnumCustom">
  <xs:union
    memberTypes="DTS:AnyNonPackageExecutableTypeExecutableTypeEnum">
    <xs:simpleType>
      <xs:restriction base="xs:string"/>
    </xs:simpleType>
  </xs:union>
</xs:simpleType>
```

2.10.1.2 ExecutableObjectType Type Replacement

In the case of custom packages, the definition of the [ExecutableObjectType](#) complex type is replaced with the following XSD definition for the **ExecutableObjectTypeCustom** complex type. All references to the **ExecutableObjectType** complex type are replaced with a reference to the **ExecutableObjectTypeCustom** complex type. The original **ExecutableObjectType** complex type has an XSD **choice** element, which allows the choice among elements specific to the variety of executable types that ship with the Microsoft® SQL Server® Integration Services (SSIS) system. In the **ExecutableObjectTypeCustom** complex type, the choice is constrained to one specific element from within the original choice, the **InnerObject** element. The Integration Services system does not interpret the contents of the **InnerObject** element, and it passes the contents to the custom executable when asked to do so.

The following is the XSD for the **ExecutableObjectTypeCustom** complex type.

```
<xs:complexType name="ExecutableObjectTypeCustom">
  <xs:choice>
    <xs:element name="InnerObject" type="DTS:InnerObjectObjectType"
      form="unqualified"/>
  </xs:choice>
</xs:complexType>
```

2.10.2 Custom ConnectionManager

Software developers can use a software development environment and a programming language to author a custom ConnectionManager to connect to a data source that is not supported by the Microsoft® SQL Server® Integration Services (SSIS) product. The custom connection manager is referenced from within the Integration Services package file like any other connection manager. When it is necessary to connect to the external data source, Integration Services executes the custom-authored code to do so.

To execute the custom connection manager code, the **DTSID** attribute of the ConnectionManager MUST be set to the GUID that references the registered COM component that implements the required interfaces or MUST be set to the full path of the Microsoft® .NET Framework assembly.

The following sections explain the impact on the XSD for custom executables.

2.10.2.1 ConnectionManagerObjectType Type Replacement

In the case of a custom ConnectionManager, the definition of the [ConnectionManagerObjectType](#) complex type is replaced with the following XSD definition for the **ConnectionManagerObjectTypeCustom** complex type. All references to the **ConnectionManagerObjectType** complex type are replaced with a reference to the **ConnectionManagerObjectTypeCustom** complex type. The Microsoft® SQL Server® Integration Services (SSIS) system does not interpret the contents of the **ObjectData** element, and it passes the contents to the custom connection manager when asked to do so.

The following is the XSD for the **ConnectionManagerObjectTypeCustom** complex type.

```
<xs:complexType name="ConnectionManagerObjectTypeCustom">
  <xs:sequence>
    <xs:any minOccurs="0" maxOccurs="unbounded"
      namespace="##any" processContents="skip"/>
  </xs:sequence>
</xs:complexType>
```

2.10.3 Custom Log Provider

Software developers can use a software development environment and a programming language to author a custom log provider to connect to and use a logging service that is not supported by the Microsoft® SQL Server® Integration Services (SSIS) product. The custom log provider is referenced from within the Integration Services package file like any other log provider. When it is necessary to access the log provider, Integration Services executes the custom-authored code to do so.

To execute the custom log provider code, the **DTSID** attribute of the LogProvider element MUST be set to the GUID that references the registered COM component that implements the required interfaces or MUST be set to the full path of the Microsoft® .NET Framework assembly.

Custom log providers impose no changes on the XSD in this document, because the [LogProviderObjectType](#) type already accommodates the presence of a custom log provider.

2.10.4 Custom ForEachEnumerator

Software developers can use a software development environment and a programming language to author a custom ForEachEnumerator to enumerate over objects for which a standard enumerator is not provided by the Microsoft® SQL Server® Integration Services (SSIS) product.

To execute the custom ForEachEnumerator code, the **DTSID** attribute of the ForEachEnumerator MUST be set to the GUID that references the registered COM component that implements the required interfaces or MUST be set to the full path of the Microsoft® .NET Framework assembly.

The following section explains the impact on the XSD for the custom ForEachEnumerator.

2.10.4.1 ForEachEnumeratorObjectType Type Replacement

In the case of a custom ForEachEnumerator, the definition of the [ForEachEnumeratorObjectType](#) complex type is replaced with the following XSD definition for the **ForEachEnumeratorObjectTypeCustom** complex type. All references to the **ForEachEnumeratorObjectType** complex type are replaced with a reference to the **ForEachEnumeratorObjectTypeCustom** complex type. The Microsoft® SQL Server®

Integration Services (SSIS) system does not interpret the contents of the **ObjectData** element, and it passes the contents to the custom connection manager when asked to do so.

The following is the XSD for the **ForEachEnumeratorObjectDataTypeCustom** complex type.

```
<xs:complexType name="ForEachEnumeratorObjectDataTypeCustom">
  <xs:sequence>
    <xs:any minOccurs="0" maxOccurs="unbounded"
      namespace="##any" processContents="skip"/>
  </xs:sequence>
</xs:complexType>
```

2.10.5 Custom Component

Software developers can use a software development environment and a programming language to author a custom component that will run within a Pipeline executable. When a custom component is authored, the author can define additional properties that are persisted in the XML beyond the properties that ship with Microsoft® SQL Server® Integration Services (SSIS). The following sections define the impact on the XSD to accommodate development of custom components.

2.10.5.1 PipelineComponentComponentClassIDEnum Type Replacement

To execute the custom component, the value of the **ComponentClassID** attribute of the component element MUST point to the custom code executable. The type of the **ComponentClassID** attribute MUST be changed to be the **PipelineComponentComponentClassIDEnumCustom** type. All references within the XSD to the [PipelineComponentComponentClassIDEnum](#) type MUST be changed to reference the **PipelineComponentComponentClassIDEnumCustom** type.

The following is the XSD for the **PipelineComponentComponentClassIDEnumCustom** type.

```
<xs:simpleType name="PipelineComponentComponentClassIDEnumCustom">
  <xs:union memberTypes="DTS:PipelineComponentComponentClassIDEnum">
    <xs:simpleType>
      <xs:restriction base="xs:string"/>
    </xs:simpleType>
  </xs:union>
</xs:simpleType>
```

2.10.5.2 PipelineComponentPropertyNameEnum Type Replacement

In a custom component, the developer can add additional properties that appear in the properties collection that is a child collection of the **component** element. To accommodate the presence of these additional properties, the [PipelineComponentPropertyNameEnum](#) type is replaced by the following definition of the **PipelineComponentPropertyNameEnumCustom** type. All references within the XSD to the **PipelineComponentPropertyNameEnum** type MUST be changed to reference the **PipelineComponentPropertyNameEnumCustom** type to accommodate the presence of custom components in the package file.

The following is the XSD for the **PipelineComponentPropertyNameEnumCustom** type.

```

<xs:simpleType name="PipelineComponentPropertyNameEnumCustom">
  <xs:union memberTypes="DTS:PipelineComponentPropertyNameEnum">
    <xs:simpleType>
      <xs:restriction base="xs:string"/>
    </xs:simpleType>
  </xs:union>
</xs:simpleType>

```

2.10.5.3 PipelineComponentInputPropertyNameEnum Type Replacement

In a custom component, the developer can add additional properties that appear in the properties collection that is a child collection of the **input** element. To accommodate the presence of these additional properties, the [PipelineComponentInputPropertyNameEnum](#) type is replaced by the following definition of the **PipelineComponentInputPropertyNameEnumCustom** type. All references within the XSD to the **PipelineComponentInputPropertyNameEnum** type MUST be changed to reference the **PipelineComponentInputPropertyNameEnumCustom** type to accommodate the presence of custom components in the package file.

The following is the XSD for the **PipelineComponentInputPropertyNameEnumCustom** type.

```

<xs:simpleType name="PipelineComponentInputPropertyNameEnumCustom">
  <xs:union memberTypes="DTS:PipelineComponentInputPropertyNameEnum">
    <xs:simpleType>
      <xs:restriction base="xs:string"/>
    </xs:simpleType>
  </xs:union>
</xs:simpleType>

```

2.10.5.4 PipelineComponentOutputPropertyNameEnum Type Replacement

In a custom component, the developer can add additional properties that appear in the properties collection that is a child collection of the **output** element. To accommodate the presence of these additional properties, the [PipelineComponentOutputPropertyNameEnum](#) type is replaced by the following definition of the **PipelineComponentOutputPropertyNameEnumCustom** type. All references within the XSD to the **PipelineComponentOutputPropertyNameEnum** type MUST be changed to reference the **PipelineComponentOutputPropertyNameEnumCustom** type to accommodate the presence of custom components in the package file.

The following is the XSD for the **PipelineComponentOutputPropertyNameEnumCustom** type.

```

<xs:simpleType name="PipelineComponentOutputPropertyNameEnumCustom">
  <xs:union memberTypes="DTS:PipelineComponentOutputPropertyNameEnum">
    <xs:simpleType>
      <xs:restriction base="xs:string"/>
    </xs:simpleType>
  </xs:union>
</xs:simpleType>

```

2.10.5.5 PipelineComponentInputColumnPropertyNameEnum Type Replacement

In a custom component, the developer can add additional properties that appear in the properties collection that is a child collection of the **inputColumn** element. To accommodate the presence of these additional properties, the [PipelineComponentInputColumnPropertyNameEnum](#) type is replaced by the following definition of the **PipelineComponentInputColumnPropertyNameEnumCustom** type. All references within the XSD to the **PipelineComponentInputColumnPropertyNameEnum** type MUST be changed to reference the **PipelineComponentInputColumnPropertyNameEnumCustom** type to accommodate the presence of custom components in the package file.

The following is the XSD for the **PipelineComponentInputColumnPropertyNameEnumCustom** type.

```
<xs:simpleType
  name="PipelineComponentInputColumnPropertyNameEnumCustom">
  <xs:union
    memberTypes="DTS:PipelineComponentInputColumnPropertyNameEnum">
    <xs:simpleType>
      <xs:restriction base="xs:string"/>
    </xs:simpleType>
  </xs:union>
</xs:simpleType>
```

2.10.5.6 PipelineComponentOutputColumnPropertyNameEnum Type Replacement

In a custom component, the developer can add additional properties that appear in the properties collection that is a child collection of the **outputColumn** element. To accommodate the presence of these additional properties, the [PipelineComponentOutputColumnPropertyNameEnum](#) type is replaced by the following definition of the **PipelineComponentOutputColumnPropertyNameEnumCustom** type. All references within the XSD to the **PipelineComponentOutputColumnPropertyNameEnum** type MUST be changed to reference the **PipelineComponentOutputColumnPropertyNameEnumCustom** type to accommodate the presence of custom components in the package file.

The following is the XSD for the **PipelineComponentOutputColumnPropertyNameEnumCustom** type.

```
<xs:simpleType
  name="PipelineComponentOutputColumnPropertyNameEnumCustom">
  <xs:union
    memberTypes="DTS:PipelineComponentOutputColumnPropertyNameEnum">
    <xs:simpleType>
      <xs:restriction base="xs:string"/>
    </xs:simpleType>
  </xs:union>
</xs:simpleType>
```

3 Structure Examples

3.1 Example of Lookup and Fuzzy Lookup Components with Error Output

The following example is taken from [Haselden], with modifications.

The following package file illustrates a Pipeline task that contains several components within the pipeline. The Microsoft® SQL Server® Integration Services (SSIS) user interface in the designer that represents this package example is shown in the following diagram.

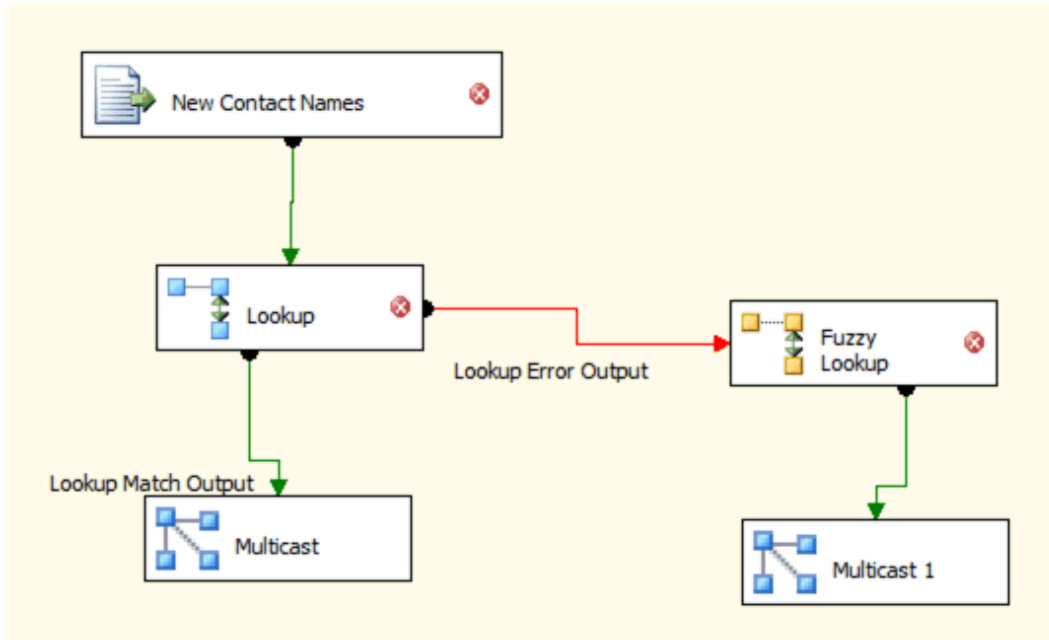

Figure 3: Pipeline task in Integration Services user interface

The [Lookup Component](#) has both a standard output and an error output. In the case of error output from the Lookup Component, the data flow path is different from the case in which the lookup operation succeeds. In the following structure example, the **inputs** element and the **outputs** element of the Lookup Component illustrate its two different output paths.

```
<?xml version="1.0"?>
<DTS:Executable xmlns:DTS="www.microsoft.com/SqlServer/Dts"
  DTS:refId="Package"
  DTS:CreationDate="7/16/2005 3:59:24 PM"
  DTS:CreationName="SSIS.Package.3"
  DTS:CreatorComputerName="ROMEO"
  DTS:CreatorName="Kirk Haselden"
  DTS:DTSID="{ECF155AC-F433-4930-A0A1-BE9B065E004D}"
  DTS:EnableConfig="True"
  DTS:ExecutableType="SSIS.Package.3"
  DTS:ExecValue="0"
  DTS:ExecValueType="3"
  DTS:LastModifiedProductVersion="11.0.1153.1"
  DTS:LocaleID="1033"
```



```

DTS:ObjectName="FuzzyLookup"
DTS:PackageType="5"
DTS:ProtectionLevel="0"
DTS:VersionBuild="51"
DTS:VersionGUID="{D4BC51B6-573E-48DA-B5E3-9F08625687A6}">
<DTS:Property
  DTS:Name="PackageFormatVersion">6</DTS:Property>
<DTS:ConnectionManagers>
  <DTS:ConnectionManager
    DTS:refId="Package.ConnectionManagers[.\SQL2K5.AdventureWorks]"
    DTS:CreationName="OLEDB"
    DTS:DTSID="{FAFAC1E8-81D4-4E0D-A5A9-ABAD9BF38826}"
    DTS:ObjectName=".\SQL2K5.AdventureWorks">
    <DTS:PropertyExpression
      DTS:Name="ServerName">@[SAMPLES::SERVERNAME]</DTS:PropertyExpression>
    <DTS:ObjectData>
      <DTS:ConnectionManager
        DTS:ConnectionString="Data Source=.;Initial Catalog=AdventureWorks;
          Provider=SQLNCLI11;Integrated Security=SSPI;Auto Translate=False;" />
      </DTS:ObjectData>
    </DTS:ConnectionManager>
  <DTS:ConnectionManager
    DTS:refId="Package.ConnectionManagers[New Contacts]"
    DTS:CreationName="FLATFILE"
    DTS:DTSID="{E97F2191-17D8-400B-9EE6-7823482A958C}"
    DTS:ObjectName="New Contacts">
    <DTS:PropertyExpression
      DTS:Name="ConnectionString">@[SAMPLES::ROOTWD] +
        "\\SAMPLEDATA\NewContacts.txt"</DTS:PropertyExpression>
    <DTS:ObjectData>
      <DTS:ConnectionManager
        DTS:Format="Delimited"
        DTS:LocaleID="1033"
        DTS:HeaderRowDelimiter="_x000D_x000A_"
        DTS:ColumnNamesInFirstDataRow="True"
        DTS:RowDelimiter=""
        DTS:TextQualifier="_x003C_none_x003E_"
        DTS:CodePage="1252"
        DTS:ConnectionString=
          "E:\BOOKSHARE\BOOKS\SSIS\SSIS_R2\SAMPLES\SAMPLEDATA\NewContacts.txt">
      <DTS:FlatFileColumns>
        <DTS:FlatFileColumn
          DTS:ColumnType="Delimited"
          DTS:ColumnDelimiter="_x0009_"
          DTS:MaximumWidth="50"
          DTS:DataType="129"
          DTS:TextQualified="True"
          DTS:ObjectName="FirstName"
          DTS:DTSID="{64661EFB-1C85-47C6-974D-BDFC7441D404}"
          DTS:CreationName="" />
        <DTS:FlatFileColumn
          DTS:ColumnType="Delimited"
          DTS:ColumnDelimiter="_x000D_x000A_"
          DTS:MaximumWidth="50"
          DTS:DataType="129"
          DTS:TextQualified="True"
          DTS:ObjectName="LastName"
          DTS:DTSID="{2DEA7754-8936-4BFB-822E-F0014DE3C9C0}"
          DTS:CreationName="" />
      </DTS:FlatFileColumns>
    </DTS:ObjectData>
  </DTS:ConnectionManager>
</DTS:ConnectionManagers>

```

```

        </DTS:FlatFileColumns>
    </DTS:ConnectionManager>
</DTS:ObjectData>
</DTS:ConnectionManager>
</DTS:ConnectionManagers>
<DTS:Configurations>
  <DTS:Configuration
    DTS:ConfigurationString="SSISSAMPLESROOT"
    DTS:ConfigurationType="2"
    DTS:ConfigurationVariable=
      "\Package.Variables[SAMPLES::ROOTWD].Properties[Value]"
    DTS:CreationName=""
    DTS:DTSID="{90405045-3A91-43C2-B759-6C183C0E81A6}"
    DTS:ObjectName="Configure The Root Folder" />
  <DTS:Configuration
    DTS:ConfigurationString="SSISSAMPLESERVER"
    DTS:ConfigurationType="2"
    DTS:ConfigurationVariable=
      "\Package.Variables[SAMPLES::SERVERNAME].Properties[Value]"
    DTS:CreationName=""
    DTS:DTSID="{A9F64F24-15C2-4198-A308-F9124C48468D}"
    DTS:ObjectName="Configure The Sample Server Name" />
  <DTS:Configuration
    DTS:ConfigurationString="SSISSAMPLESWORKINGFOLDER"
    DTS:ConfigurationType="2"
    DTS:ConfigurationVariable=
      "\Package.Variables[SAMPLES::WORKINGFOLDER].Properties[Value]"
    DTS:CreationName=""
    DTS:DTSID="{1BAB0708-C962-4F9B-BFD6-EC434567ACAF}"
    DTS:ObjectName="Configure the Working Folder variable" />
</DTS:Configurations>
<DTS:Variables>
  <DTS:Variable
    DTS:CreationName=""
    DTS:DTSID="{E05C4384-FA46-4EDB-9E41-E0CDD6DD4DC6}"
    DTS:EvaluateAsExpression="True"
    DTS:Expression="@ROOTWD + &quot;\\&quot; + @SAMPLESUBFOLDER"
    DTS:IncludeInDebugDump="2345"
    DTS:Namespace="SAMPLES"
    DTS:ObjectName="CURRENTWD">
    <DTS:VariableValue
      DTS:DataType="8">E:\BOOKSHARE\BOOKS\SSIS\SSIS_R2\SAMPLES\S21-Advanced
    </DTS:VariableValue>
  </DTS:Variable>
  <DTS:Variable
    DTS:CreationName=""
    DTS:DTSID="{3BD365BA-FE06-4B5A-8100-69F27C71B74E}"
    DTS:IncludeInDebugDump="2345"
    DTS:Namespace="SAMPLES"
    DTS:ObjectName="ROOTWD">
    <DTS:VariableValue
      DTS:DataType="8">E:\BOOKSHARE\BOOKS\SSIS\SSIS_R2\SAMPLES
    </DTS:VariableValue>
  </DTS:Variable>
  <DTS:Variable
    DTS:CreationName=""
    DTS:DTSID="{6E7FB8C5-7F98-454E-87E0-D9BF0D0E06AD}"
    DTS:IncludeInDebugDump="2345"
    DTS:Namespace="SAMPLES"

```

```

    DTS:ObjectName="SAMPLESUBFOLDER">
    <DTS:VariableValue
      DTS:DataType="8">S21-Advanced</DTS:VariableValue>
    </DTS:Variable>
  <DTS:Variable
    DTS:CreationName=""
    DTS:DTSID="{5F9998D0-186D-4C44-A949-66C8477A3CE7}"
    DTS:IncludeInDebugDump="2345"
    DTS:Namespace="SAMPLES"
    DTS:ObjectName="SERVERNAME">
    <DTS:VariableValue
      DTS:DataType="8">.</DTS:VariableValue>
    </DTS:Variable>
  <DTS:Variable
    DTS:CreationName=""
    DTS:DTSID="{DC4065D8-A163-4893-BE71-FB0D146F3BA8}"
    DTS:IncludeInDebugDump="2345"
    DTS:Namespace="SAMPLES"
    DTS:ObjectName="WORKINGFOLDER">
    <DTS:VariableValue
      DTS:DataType="8">E:\BOOKSHARE\BOOKS\SSIS\SSIS_R2\SAMPLES\SCRATCH
    </DTS:VariableValue>
    </DTS:Variable>
</DTS:Variables>
<DTS:Executables>
  <DTS:Executable
    DTS:refId="Package\Data Flow Task"
    DTS:CreationName="SSIS.Pipeline.3"
    DTS:Description="Data Flow Task"
    DTS:DTSID="{7FAA584E-2F45-4786-8410-8E97F54B0E8D}"
    DTS:ExecutableType="SSIS.Pipeline.3"
    DTS:ExecValue="0"
    DTS:ExecValueType="3"
    DTS:LocaleID="-1"
    DTS:ObjectName="Data Flow Task"
    DTS:TaskContact="Performs high-performance data extraction,
    transformation and loading;Microsoft Corporation;
    Microsoft SQL Server v9; (C) 2004 Microsoft Corporation;
    All Rights Reserved;http://www.microsoft.com/sql/support/default.asp;1">
    <DTS:Variables />
    <DTS:ObjectData>
      <pipeline
        BLOBTempStoragePath=""
        bufferTempStoragePath=""
        engineThreads="5"
        id="0"
        runInOptimizedMode="false"
        version="1">
        <components>
          <component
            refId="Package\Data Flow Task\Fuzzy Lookup"
            componentClassID="{E4A5F949-EC93-45AB-8B36-B52936257EC2}"
            contactInfo="Fuzzy Lookup;Microsoft Corporation;
            Microsoft SqlServer v9; (C) 2005 Microsoft Corporation;
            All Rights Reserved; http://www.microsoft.com/sql/support;5"
            description=
            "Looks up values in a reference dataset by using fuzzy matching."
            name="Fuzzy Lookup"
            version="5">

```

```

<properties>
  <property
    dataType="System.Int32"
description="Indicates whether to reuse an existing fuzzy-match index
table or build a new one. The new index table can be temporary,
persisted, or persisted and maintained."
    name="MatchIndexOptions"
    typeConverter="tcMatchIndexOptions">1</property>
  <property
    dataType="System.Null"
description="Specifies the maximum amount of memory (MB)
that this instance of the Fuzzy Lookup transformation can
use. If 0 is given, then the transform will dynamically
adjust it's memory usage based upon it's requirements and
available system memory."
    expressionType="Notify"
    name="MaxMemoryUsage" />
  <property
    dataType="System.String"
description="Specifies the name of the fuzzy-match index
table to be reused or the table name in which a newly
generated fuzzy-match index table will be written."
    name="MatchIndexName"
    state="escaped">ContactsMatchIndex</property>
  <property
    dataType="System.String"
description="Specifies the name of the reference table
or view against which to match incoming records."
    name="ReferenceTableName"
    state="escaped">_x005B_Person_x005D_. _x005B_Contact_x005D_
  </property>
  <property
    dataType="System.Int32"
description="Indicates whether to drop an existing
fuzzy-match index table if transformation is configured to
generate a new table and a table with the same name already
exists."
    name="DropExistingMatchIndex">1</property>
  <property
    dataType="System.Int32"
description="Whether a copy of the reference table should
be made for fuzzy match index construction and subsequent
matching. It is strongly recommended that a copy always
be made, otherwise unpredictable output may result if the
contents of the reference table change during package
execution (or between executions if reusing a fuzzy
match index). If this property is set to false, the
reference table must additionally have a clustered index
built upon an integer identity column."
    name="CopyReferenceTable">1</property>
  <property
    dataType="System.UInt32"
description="Specifies the maximum number of fuzzy matches
to return for an input record."
    name="MaxOutputMatchesPerInput">1</property>
  <property
    dataType="System.Single"
description="Specifies the minimum similarity score
required for the match results that the transformation

```

```

        returns."
        name="MinSimilarity">0.65</property>
    <property
        dataType="System.String"
        description="Specifies the set of white-space and
        punctuation characters used to separate fuzzy match
        fields into the words used for matching and scoring a
        fuzzy lookup."
        name="Delimiters"
        state="escaped">
_x0020_x0009_x000D_x000A_x002C_x003B:-_x0022_x0027_x0026_x002F__
x005C_x0040_x0021_x003F_x0028_x0029_x003C_x003E_x005B_x005D_x007B
_x007D_x007C_x0023_x002A_x005E_x0025_</property>
    <property
        dataType="System.String"
        description="Specifies the metadata of the reference
        table in XML format."
        name="ReferenceMetadataXml"
        state="escaped">_x003C_referenceMetadata_x003E_x003C_
referenceColumns_x003E_x003C_referenceColumn_x0020_name_x003D_x0022_
ContactID_x0022_x0020_dataType_x003D_x0022_DT_I4_x0022_x0020_length_x003D
_x0022_0_x0022_x0020_precision_x003D_x0022_0_x0022_x0020_scale_x003D__
_x0022_0_x0022_x0020_codePage_x003D_x0022_0_x0022_x002F_x003E_x003C_
referenceColumn_x0020_name_x003D_x0022_NameStyle_x0022_x0020_dataType_
_x003D_x0022_DT_BOOL_x0022_x0020_length_x003D_x0022_0_x0022_x0020_
precision_x003D_x0022_0_x0022_x0020_scale_x003D_x0022_0_x0022_x0020_
codePage_x003D_x0022_0_x0022_x002F_x003E_x003C_referenceColumn_x0020_
name_x003D_x0022_Title_x0022_x0020_dataType_x003D_x0022_DT_WSTR_x0022_
_x0020_length_x003D_x0022_8_x0022_x0020_precision_x003D_x0022_0_x0022_
_x0020_scale_x003D_x0022_0_x0022_x0020_codePage_x003D_x0022_0_x0022_
_x002F_x003E_x003C_referenceColumn_x0020_name_x003D_x0022_FirstName_x0022
_x0020_dataType_x003D_x0022_DT_WSTR_x0022_x0020_length_x003D_x0022_50_
_x0022_x0020_precision_x003D_x0022_0_x0022_x0020_scale_x003D_x0022_0_
_x0022_x0020_codePage_x003D_x0022_0_x0022_x002F_x003E_x003C_
referenceColumn_x0020_name_x003D_x0022_MiddleName_x0022_x0020_dataType_
_x003D_x0022_DT_WSTR_x0022_x0020_length_x003D_x0022_50_x0022_x0020_
precision_x003D_x0022_0_x0022_x0020_scale_x003D_x0022_0_x0022_x0020_
codePage_x003D_x0022_0_x0022_x002F_x003E_x003C_referenceColumn_x0020_
name_x003D_x0022_LastName_x0022_x0020_dataType_x003D_x0022_DT_WSTR_x0022
_x0020_length_x003D_x0022_50_x0022_x0020_precision_x003D_x0022_0_x0022_
_x0020_scale_x003D_x0022_0_x0022_x0020_codePage_x003D_x0022_0_x0022_x002F
_x003E_x003C_referenceColumn_x0020_name_x003D_x0022_Suffix_x0022_x0020_
_dataType_x003D_x0022_DT_WSTR_x0022_x0020_length_x003D_x0022_10_x0022_
_x0020_precision_x003D_x0022_0_x0022_x0020_scale_x003D_x0022_0_x0022_
_x0020_codePage_x003D_x0022_0_x0022_x002F_x003E_x003C_referenceColumn_
_x0020_name_x003D_x0022_EmailAddress_x0022_x0020_dataType_x003D_x0022_DT_
_WSTR_x0022_x0020_length_x003D_x0022_50_x0022_x0020_precision_x003D_
_x0022_0_x0022_x0020_scale_x003D_x0022_0_x0022_x0020_codePage_x003D_x0022
_0_x0022_x002F_x003E_x003C_referenceColumn_x0020_name_x003D_x0022_
EmailPromotion_x0022_x0020_dataType_x003D_x0022_DT_I4_x0022_x0020_length
_x003D_x0022_0_x0022_x0020_precision_x003D_x0022_0_x0022_x0020_scale_
_x003D_x0022_0_x0022_x0020_codePage_x003D_x0022_0_x0022_x002F_x003E_
_x003C_referenceColumn_x0020_name_x003D_x0022_Phone_x0022_x0020_dataType_
_x003D_x0022_DT_WSTR_x0022_x0020_length_x003D_x0022_25_x0022_x0020_
precision_x003D_x0022_0_x0022_x0020_scale_x003D_x0022_0_x0022_x0020_
codePage_x003D_x0022_0_x0022_x002F_x003E_x003C_referenceColumn_x0020_
name_x003D_x0022_PasswordHash_x0022_x0020_dataType_x003D_x0022_DT_STR_
_x0022_x0020_length_x003D_x0022_40_x0022_x0020_precision_x003D_x0022_0_
_x0022_x0020_scale_x003D_x0022_0_x0022_x0020_codePage_x003D_x0022_1252_

```

```

x0022_x002F_x003E_x003C_referenceColumn_x0020_name_x003D_x0022_
PasswordSalt_x0022_x0020_dataType_x003D_x0022_DT_STR_x0022_x0020_
length_x003D_x0022_10_x0022_x0020_precision_x003D_x0022_0_x0022_
x0020_scale_x003D_x0022_0_x0022_x0020_codePage_x003D_x0022_1252_x0022_
x002F_x003E_x003C_referenceColumn_x0020_name_x003D_x0022_
AdditionalContactInfo_x0022_x0020_dataType_x003D_x0022_DT_NTEXT_x0022_
x0020_length_x003D_x0022_0_x0022_x0020_precision_x003D_x0022_0_x0022_
x0020_scale_x003D_x0022_0_x0022_x0020_codePage_x003D_x0022_0_x0022_
x002F_x003E_x003C_referenceColumn_x0020_name_x003D_x0022_rowguid_x0022_
x0020_dataType_x003D_x0022_DT_GUID_x0022_x0020_length_x003D_x0022_0_x0022_
_x0020_precision_x003D_x0022_0_x0022_x0020_scale_x003D_x0022_0_x0022_
x0020_codePage_x003D_x0022_0_x0022_x002F_x003E_x003C_referenceColumn_
x0020_name_x003D_x0022_ModifiedDate_x0022_x0020_dataType_x003D_x0022_DT_
DBTIMESTAMP_x0022_x0020_length_x003D_x0022_0_x0022_x0020_precision_x003D
_x0022_0_x0022_x0020_scale_x003D_x0022_0_x0022_x0020_codePage_x003D_
x0022_0_x0022_x002F_x003E_x003C_x002F_referenceColumns_x003E_x003C_
x002F_referenceMetadata_x003E_x000D_x000A_</property>
  <property
    dataType="System.Boolean"
    description="If true, each input record will be directly compared
    against EVERY record in the reference table. This may produce slightly
    better results, but will be extremely slow unless the number of records
    in the reference table is very small. Note that the entire reference
    table will be loaded into main memory if this option is enabled.
    This option is primarily intended for debugging purposes and should
    be used with care."
    name="Exhaustive">false</property>
  <property
    dataType="System.Boolean"
    description="If true, Fuzzy Lookup will partially load the error-tolerant
    index and the reference table into main memory before execution begins.
    This can greatly enhance performance if many input rows are to be
    processed."
    name="WarmCaches">>true</property>
</properties>
<connections>
  <connection
    refId=
      "Package\Data Flow Task\Fuzzy Lookup.Connections[OleDbConnection]"
    connectionManagerID=
      "Package.ConnectionManagers[.\SQL2K5.AdventureWorks]"
    description="Microsoft SQL Server connection and database in which the
    fuzzy lookup reference table is located and where the fuzzy match
    index table will be stored and accessed."
    name="OleDbConnection" />
</connections>
<inputs>
  <input
    refId="Package\Data Flow Task\Fuzzy Lookup.Inputs[Fuzzy Lookup Input]"
    name="Fuzzy Lookup Input">
    <inputColumns>
      <inputColumn
        refId="Package\Data Flow Task\Fuzzy Lookup.Inputs
        [Fuzzy Lookup Input].Columns[FirstName]"
        cachedDataType="wstr"
        cachedLength="50"
        cachedName="FirstName"
        lineageId="Package\Data Flow Task\New Contact Names.Outputs
        [Flat File Source Output].Columns[FirstName]">

```

```

        <properties>
            <property
                dataType="System.String"
                description="Name of the reference table column with which the input
                column should be matched."
                name="JoinToReferenceColumn"
                state="escaped">FirstName</property>
            <property
                dataType="System.Int32"
                description="Specifies whether the match is a fuzzy or an exact match."
                name="JoinType"
                typeConverter="tcJoinType">2</property>
            <property
                dataType="System.Single"
                description="Specifies the minimum textual similarity required between
                input and fuzzy matched records on values in this particular join column.
                Must be a floating point value between 0.0 and 1.0."
                name="MinSimilarity">0</property>
            <property
                dataType="System.Int32"
                description="Specifies the comparison options for character data.
                The options are those supported by the FoldString function."
                name="FuzzyComparisonFlags"
                typeConverter="tcComparisonFlags">1</property>
            <property
                dataType="System.UInt32"
                description="Flags to FoldString that should be used when comparing
                whether two strings are equivalent."
                name="FuzzyComparisonFlagsEx"
                typeConverter="tcComparisonFlagsEx">0</property>
        </properties>
    </inputColumn>
    <inputColumn
        refId="Package\Data Flow Task\Fuzzy Lookup.Inputs
        [Fuzzy Lookup Input].Columns[LastName]"
        cachedDataType="wstr"
        cachedLength="50"
        cachedName="LastName"
        lineageId="Package\Data Flow Task\New Contact Names.Outputs
        [Flat File Source Output].Columns[LastName]">
        <properties>
            <property
                dataType="System.String"
                description="Name of the reference table column with which the
                input column should be matched."
                name="JoinToReferenceColumn"
                state="escaped">LastName</property>
            <property
                dataType="System.Int32"
                description="Specifies whether the match is a fuzzy or an exact match."
                name="JoinType"
                typeConverter="tcJoinType">2</property>
            <property
                dataType="System.Single"
                description="Specifies the minimum textual similarity required between
                input and fuzzy matched records on values in this particular join column.
                Must be a floating point value between 0.0 and 1.0."
                name="MinSimilarity">0</property>
        </property>
    </inputColumn>

```

```

        dataType="System.Int32"
description="Specifies the comparison options for character data.
The options are those supported by the FoldString function."
        name="FuzzyComparisonFlags"
        typeConverter="tcComparisonFlags">1</property>
    <property
        dataType="System.UInt32"
description="Flags to FoldString that should be used when comparing
whether two strings are equivalent."
        name="FuzzyComparisonFlagsEx"
        typeConverter="tcComparisonFlagsEx">0</property>
    </properties>
</inputColumn>
</inputColumns>
<externalMetadataColumns />
</input>
</inputs>
<outputs>
    <output
refId="Package\Data Flow Task\Fuzzy Lookup.Outputs[Fuzzy Lookup Output]"
        name="Fuzzy Lookup Output">
        <outputColumns>
            <outputColumn
refId="Package\Data Flow Task\Fuzzy Lookup.Outputs[Fuzzy Lookup Output].
Columns[FirstName]"
                dataType="wstr"
                length="50"
lineageId="Package\Data Flow Task\Fuzzy Lookup.Outputs
[Fuzzy Lookup Output].Columns[FirstName]"
                name="FirstName">
                <properties>
                    <property
                        dataType="System.Null"
description="Specifies the reference table column that is copied to the
output for each match result."
                        name="CopyFromReferenceColumn"
                        state="escaped" />
                    <property
                        containsID="true"
                        dataType="System.Int32"
description="Specifies the lineage identifier of the input column from
which to copy to this output column for each match."
                        name="SourceInputColumnLineageID">
                    #{Package\Data Flow Task\New Contact Names.Outputs[Flat File Source Output]
.Columns[FirstName]}</property>
                    <property
                        dataType="System.Int32"
description="Specifies whether the column is used to indicate confidence
or similarity."
                        name="ColumnType"
                        typeConverter="tcColumnType">0</property>
                    </properties>
                </outputColumn>
            <outputColumn
refId="Package\Data Flow Task\Fuzzy Lookup.Outputs[Fuzzy Lookup Output].
Columns[LastName]"
                dataType="wstr"
                length="50"
                lineageId="Package\Data Flow Task\Fuzzy Lookup.

```



```

        Outputs[Fuzzy Lookup Output].Columns[LastName]"
        name="LastName">
        <properties>
            <property
                dataType="System.Null"
description="Specifies the reference table column that is copied to the
output for each match result."
                name="CopyFromReferenceColumn"
                state="escaped" />
            <property
                containsID="true"
                dataType="System.Int32"
description="Specifies the lineage identifier of the input column from
which to copy to this output column for each match."
                name="SourceInputColumnLineageID">
        #{Package\Data Flow Task\New Contact Names.Outputs[Flat File Source
Output].Columns[LastName]}</property>
            <property
                dataType="System.Int32"
description="Specifies whether the column is used to indicate
confidence or similarity."
                name="ColumnType"
                typeConverter="tcColumnType">0</property>
        </properties>
    </outputColumn>
</outputColumn
    refId="Package\Data Flow Task\Fuzzy Lookup.Outputs
[Fuzzy Lookup Output].Columns[FLFirstName]"
    dataType="wstr"
    length="50"
    lineageId="Package\Data Flow Task\Fuzzy Lookup.Outputs[Fuzzy
Lookup Output].Columns[FLFirstName]"
    name="FLFirstName">
    <properties>
        <property
            dataType="System.String"
description="Specifies the reference table column that is copied to the
output for each match result."
            name="CopyFromReferenceColumn"
            state="escaped">FirstName</property>
        <property
            containsID="true"
            dataType="System.Null"
description="Specifies the lineage identifier of the input column
from which to copy to this output column for each match."
            name="SourceInputColumnLineageID" />
        <property
            dataType="System.Int32"
description="Specifies whether the column is used to indicate
confidence or similarity."
            name="ColumnType"
            typeConverter="tcColumnType">0</property>
    </properties>
</outputColumn>
</outputColumn
    refId="Package\Data Flow Task\Fuzzy Lookup.Outputs
[Fuzzy Lookup Output].Columns[FLLastName]"
    dataType="wstr"
    length="50"

```

```

        lineageId="Package\Data Flow Task\Fuzzy Lookup.Outputs
[Fuzzy Lookup Output].Columns[FLLastName]"
        name="FLLastName">
        <properties>
            <property
                dataType="System.String"
description="Specifies the reference table column that is copied to
the output for each match result."
                name="CopyFromReferenceColumn"
                state="escaped">LastName</property>
            <property
                containsID="true"
                dataType="System.Null"
description="Specifies the lineage identifier of the input column from
which to copy to this output column for each match."
                name="SourceInputColumnLineageID" />
            <property
                dataType="System.Int32"
description="Specifies whether the column is used to indicate
confidence or similarity."
                name="ColumnType"
                typeConverter="tcColumnType">0</property>
        </properties>
    </outputColumn>
    <outputColumn
        refId="Package\Data Flow Task\Fuzzy Lookup.Outputs
[Fuzzy Lookup Output].Columns[_Similarity]"
        dataType="r4"
        lineageId="Package\Data Flow Task\Fuzzy Lookup.Outputs
[Fuzzy Lookup Output].Columns[_Similarity]"
        name="_Similarity">
        <properties>
            <property
                dataType="System.Int32"
description="Specifies whether the column is used to indicate confidence
or similarity."
                name="ColumnType"
                typeConverter="tcColumnType">1</property>
        </properties>
    </outputColumn>
    <outputColumn
        refId="Package\Data Flow Task\Fuzzy Lookup.Outputs
[Fuzzy Lookup Output].Columns[_Confidence]"
        dataType="r4"
        lineageId="Package\Data Flow Task\Fuzzy Lookup.Outputs
[Fuzzy Lookup Output].Columns[_Confidence]"
        name="_Confidence">
        <properties>
            <property
                dataType="System.Int32"
description="Specifies whether the column is used to indicate confidence
or similarity."
                name="ColumnType"
                typeConverter="tcColumnType">2</property>
        </properties>
    </outputColumn>
    <outputColumn
        refId="Package\Data Flow Task\Fuzzy Lookup.Outputs
[Fuzzy Lookup Output].Columns[_Similarity_FirstName]"

```

```

        dataType="r4"
        description="Column-level similarity score for fuzzy
        join on column "FirstName"."
        lineageId="Package\Data Flow Task\Fuzzy Lookup.Outputs
        [Fuzzy Lookup Output].Columns[_Similarity_FirstName]"
        name="_Similarity_FirstName">
    <properties>
        <property
            dataType="System.Null"
            description="Specifies the reference table column that is copied to the
            output for each match result."
            name="CopyFromReferenceColumn"
            state="escaped" />
        <property
            containsID="true"
            dataType="System.Int32"
            description="Specifies the lineage identifier of the input column from
            which to copy to this output column for each match."
            name="SourceInputColumnNameID">
    #{Package\Data Flow Task\New Contact Names.Outputs[Flat File Source Output]
    .Columns[FirstName]}</property>
        <property
            dataType="System.Int32"
            description="Specifies whether the column is used to indicate confidence
            or similarity."
            name="ColumnType"
            typeConverter="tcColumnType">3</property>
    </properties>
</outputColumn>
<outputColumn
    refId="Package\Data Flow Task\Fuzzy Lookup.Outputs
    [Fuzzy Lookup Output].Columns[_Similarity_LastName]"
    dataType="r4"
    description="Column-level similarity score for fuzzy
    join on column "LastName"."
    lineageId="Package\Data Flow Task\Fuzzy Lookup.Outputs
    [Fuzzy Lookup Output].Columns[_Similarity_LastName]"
    name="_Similarity_LastName">
    <properties>
        <property
            dataType="System.Null"
            description="Specifies the reference table column that is copied to the
            output for each match result."
            name="CopyFromReferenceColumn"
            state="escaped" />
        <property
            containsID="true"
            dataType="System.Int32"
            description="Specifies the lineage identifier of the input column from
            which to copy to this output column for each match."
            name="SourceInputColumnNameID">
    #{Package\Data Flow Task\New Contact Names.Outputs[Flat File Source Output].
    Columns[LastName]}</property>
        <property
            dataType="System.Int32"
            description="Specifies whether the column is used to indicate confidence
            or similarity."
            name="ColumnType"
            typeConverter="tcColumnType">3</property>

```

```

        </properties>
    </outputColumn>
</outputColumns>
<externalMetadataColumns />
</output>
</outputs>
</component>
<component
    refId="Package\Data Flow Task\Lookup"
    componentClassID="{671046B0-AA63-4C9F-90E4-C06E0B710CE3}"
    contactInfo="Lookup;Microsoft Corporation;Microsoft SqlServer
v9; (C) 2005 Microsoft Corporation; All Rights Reserved;
http://www.microsoft.com/sql/support;4"
description="Looks up values in a reference dataset by using exact matching."
    name="Lookup"
    usesDispositions="true"
    version="6">
    <properties>
        <property
            dataType="System.String"
            description="Specifies the SQL statement that generates the lookup table."
            expressionType="Notify"
            name="SqlCommand"
            UITypeEditor="Microsoft.DataTransformationServices.Controls.
ModalMultilineStringEditor, Microsoft.DataTransformationServices.Controls,
Version=11.0.0.0, Culture=neutral, PublicKeyToken=89845dcd8080cc91">
            select * from [Person].[Contact]</property>
        <property
            dataType="System.String"
            description="Specifies a SQL statement that uses parameters to generate
the lookup table."
            expressionType="Notify"
            name="SqlCommandParam">select * from (select * from
[Person].[Contact]) [refTable] where [refTable].
[FirstName] = ? and [refTable].[LastName] = ?
</property>
        <property
            dataType="System.Int32"
            description="Specifies the cache type of the lookup table."
            name="CacheType"
            typeConverter="CacheType">1</property>
        <property
            dataType="System.Int32"
            description="Maximum Memory Usage for Reference Cache on a 32 bit
platform."
            name="MaxMemoryUsage">25</property>
        <property
            dataType="System.Int64"
            description="Maximum Memory Usage for Reference Cache on a 64 bit
platform."
            name="MaxMemoryUsage64">25</property>
        <property
            dataType="System.String"
            description="Indicates whether to reference metadata in an XML format."
            name="ReferenceMetadataXml">
            &lt;referenceMetadata&gt;&lt;referenceColumns&gt;&lt;referenceColumn name=
"ContactID" dataType="DT_I4" length="0" precision="0" scale="0" codePage="0"
/&gt;&lt;referenceColumn name="NameStyle" dataType="DT_BOOL" length="0"
precision="0" scale="0" codePage="0"/&gt;&lt;referenceColumn name="Title"

```

```

dataType="DT_WSTR" length="8" precision="0" scale="0" codePage="0"/&gt;&lt;
referenceColumn name="FirstName" dataType="DT_WSTR" length="50" precision=
"0" scale="0" codePage="0"/&gt;&lt;referenceColumn name="MiddleName"
dataType="DT_WSTR" length="50" precision="0" scale="0" codePage="0"/&gt;&lt;
referenceColumn name="LastName" dataType="DT_WSTR" length="50" precision="0"
scale="0" codePage="0"/&gt;&lt;referenceColumn name="Suffix" dataType=
"DT_WSTR" length="10" precision="0" scale="0" codePage="0"/&gt;&lt;
referenceColumn name="EmailAddress" dataType="DT_WSTR" length="50"
precision="0" scale="0" codePage="0"/&gt;&lt;referenceColumn name=
"EmailPromotion" dataType="DT_I4" length="0" precision="0" scale="0"
codePage="0"/&gt;&lt;referenceColumn name="Phone" dataType="DT_WSTR"
length="25" precision="0" scale="0" codePage="0"/&gt;&lt;referenceColumn
name="PasswordHash" dataType="DT_STR" length="128" precision="0" scale="0"
codePage="1252"/&gt;&lt;referenceColumn name="PasswordSalt" dataType=
"DT_STR" length="10" precision="0" scale="0" codePage="1252"/&gt;&lt;
referenceColumn name="AdditionalContactInfo" dataType="DT_NTEXT" length="0"
precision="0" scale="0" codePage="0"/&gt;&lt;referenceColumn name="rowguid"
dataType="DT_GUID" length="0" precision="0" scale="0" codePage="0"/&gt;&lt;
referenceColumn name="ModifiedDate" dataType="DT_DBTIMESTAMP" length="0"
precision="0" scale="0" codePage="0"/&gt;&lt;/referenceColumns&gt;&lt;
/referenceMetadata&gt;</property>
  <property
    containsID="true"
    dataType="System.String"
    description="Specifies the list of lineage identifiers that map to the
parameters that the SQL statement in the SQLCommand property uses.
Entries in the list are separated by semicolons."
    name="ParameterMap">#{Package\Data Flow Task\New Contact Names.Outputs
[Flat File Source Output].Columns[FirstName]};#{Package\Data Flow Task\
New Contact Names.Outputs[Flat File Source Output].Columns[LastName]};
</property>
  <property
    dataType="System.Int32"
    description="Specifies the column code page to use when code page
information is unavailable from the data source."
    name="DefaultCodePage">1252</property>
  <property
    dataType="System.Int32"
    description="Specifies the type of connection used to access the
reference dataset."
    name="ConnectionType"
    typeConverter="LookupConnectionType">0</property>
  <property
    dataType="System.Int32"
    description="Specifies how the Lookup transformation handles rows without
matching entries in the reference data set."
    name="NoMatchBehavior"
    typeConverter="LookupNoMatchBehavior">0</property>
  <property
    dataType="System.Int32"
    description="Specifies the percentage of the cache that is allocated for
rows with no matching entries in the reference dataset."
    name="NoMatchCachePercentage">0</property>
  <property
    dataType="System.Boolean"
    description="Determines whether duplicate keys in the reference data
should be treated as errors when full cache mode is used."
    name="TreatDuplicateKeysAsError">>false</property>
</properties>

```

```

    <connections>
      <connection
refId="Package\Data Flow Task\Lookup.Connections[OleDbConnection]"
      connectionManagerID="Package.ConnectionManagers
[.\SQL2K5.AdventureWorks]"
description="Connection manager used to access lookup data."
      name="OleDbConnection" />
    </connections>
    <inputs>
      <input
refId="Package\Data Flow Task\Lookup.Inputs
[Lookup Input]"
      name="Lookup Input">
        <inputColumns>
          <inputColumn
refId="Package\Data Flow Task\Lookup.Inputs
[Lookup Input].Columns[FirstName]"
          cachedDataType="wstr"
          cachedLength="50"
          cachedName="FirstName"
lineageId="Package\Data Flow Task\New Contact Names.Outputs
[Flat File Source Output].Columns[FirstName]">
            <properties>
              <property
description="Specifies the column in the reference table that
a column joins."
                name="JoinToReferenceColumn">
                  FirstName</property>
              <property
description="Specifies the column in the reference table from
which a column is copied."
                name="CopyFromReferenceColumn" />
            </properties>
          </inputColumn>
          <inputColumn
refId="Package\Data Flow Task\Lookup.Inputs[Lookup Input].
Columns[LastName]"
          cachedDataType="wstr"
          cachedLength="50"
          cachedName="LastName"
lineageId="Package\Data Flow Task\New Contact Names.Outputs
[Flat File Source Output].Columns[LastName]">
            <properties>
              <property
description="Specifies the column in the reference table that
a column joins."
                name="JoinToReferenceColumn">LastName</property>
              <property
description="Specifies the column in the reference table from which
a column is copied."
                name="CopyFromReferenceColumn" />
            </properties>
          </inputColumn>
        </inputColumns>
      </input>
    </inputs>
  </externalMetadataColumns />

```

```

        </input>
    </inputs>
    <outputs>
        <output
            refId="Package\Data Flow Task\Lookup.Outputs[Lookup Match Output]"
            errorOrTruncationOperation="Lookup"
            errorRowDisposition="RedirectRow"
            exclusionGroup="1"
            name="Lookup Match Output"
            synchronousInputId="Package\Data Flow Task\Lookup.
            Inputs[Lookup Input]">
            <outputColumns>
                <outputColumn
                    refId="Package\Data Flow Task\Lookup.Outputs[Lookup Match Output].
                    Columns[LUFirstName]"
                    dataType="wstr"
                    errorOrTruncationOperation="Copy Column"
                    length="50"
                    lineageId="Package\Data Flow Task\Lookup.Outputs
                    [Lookup Match Output].Columns[LUFirstName]"
                    name="LUFirstName"
                    truncationRowDisposition="FailComponent">
                    <properties>
                        <property
                            dataType="System.String"
                            description="Specifies the column in the reference table from
                            which a column is copied."
                            name="CopyFromReferenceColumn">FirstName</property>
                    </properties>
                </outputColumn>
                <outputColumn
                    refId="Package\Data Flow Task\Lookup.Outputs
                    [Lookup Match Output].Columns[LULastName]"
                    dataType="wstr"
                    errorOrTruncationOperation="Copy Column"
                    length="50"
                    lineageId="Package\Data Flow Task\Lookup.Outputs
                    [Lookup Match Output].Columns[LULastName]"
                    name="LULastName"
                    truncationRowDisposition="FailComponent">
                    <properties>
                        <property
                            dataType="System.String"
                            description="Specifies the column in the reference table from
                            which a column is copied."
                            name="CopyFromReferenceColumn">LastName</property>
                    </properties>
                </outputColumn>
                <outputColumn
                    refId="Package\Data Flow Task\Lookup.Outputs
                    [Lookup Match Output].Columns[NameStyle]"
                    dataType="bool"
                    errorOrTruncationOperation="Copy Column"
                    lineageId="Package\Data Flow Task\Lookup.Outputs
                    [Lookup Match Output].Columns[NameStyle]"
                    name="NameStyle"
                    truncationRowDisposition="FailComponent">
                    <properties>
                        <property

```

```

        dataType="System.String"
description="Specifies the column in the reference table from
which a column is copied."
        name="CopyFromReferenceColumn">NameStyle
    </property>
</properties>
</outputColumn>
<outputColumn
    refId="Package\Data Flow Task\Lookup.Outputs
[Lookup Match Output].Columns[Title]"
    dataType="wstr"
    errorOrTruncationOperation="Copy Column"
    length="8"
    lineageId="Package\Data Flow Task\Lookup.Outputs
[Lookup Match Output].Columns[Title]"
    name="Title"
    truncationRowDisposition="FailComponent">
    <properties>
        <property
            dataType="System.String"
description="Specifies the column in the reference table from
which a column is copied."
            name="CopyFromReferenceColumn">Title</property>
        </properties>
    </outputColumn>
<outputColumn
    refId="Package\Data Flow Task\Lookup.Outputs
[Lookup Match Output].Columns[MiddleName]"
    dataType="wstr"
    errorOrTruncationOperation="Copy Column"
    length="50"
    lineageId="Package\Data Flow Task\Lookup.Outputs
[Lookup Match Output].Columns[MiddleName]"
    name="MiddleName"
    truncationRowDisposition="FailComponent">
    <properties>
        <property
            dataType="System.String"
description="Specifies the column in the reference table
from which a column is copied."
            name="CopyFromReferenceColumn">MiddleName</property>
        </properties>
    </outputColumn>
<outputColumn
    refId="Package\Data Flow Task\Lookup.Outputs
[Lookup Match Output].Columns[Suffix]"
    dataType="wstr"
    errorOrTruncationOperation="Copy Column"
    length="10"
    lineageId="Package\Data Flow Task\Lookup.
Outputs[Lookup Match Output].Columns[Suffix]"
    name="Suffix"
    truncationRowDisposition="FailComponent">
    <properties>
        <property
            dataType="System.String"
description="Specifies the column in the reference table
from which a column is copied."
            name="CopyFromReferenceColumn">Suffix</property>

```



```

        </properties>
    </outputColumn>
    <outputColumn
        refId="Package\Data Flow Task\Lookup.Outputs
        [Lookup Match Output].Columns[EmailAddress]"
        dataType="wstr"
        errorOrTruncationOperation="Copy Column"
        length="50"
        lineageId="Package\Data Flow Task\Lookup.Outputs
        [Lookup Match Output].Columns[EmailAddress]"
        name="EmailAddress"
        truncationRowDisposition="FailComponent">
    <properties>
        <property
            dataType="System.String"
description="Specifies the column in the reference table
from which a column is copied."
            name="CopyFromReferenceColumn">EmailAddress</property>
    </properties>
    </outputColumn>
    <outputColumn
        refId="Package\Data Flow Task\Lookup.Outputs
        [Lookup Match Output].Columns[EmailPromotion]"
        dataType="i4"
        errorOrTruncationOperation="Copy Column"
        lineageId="Package\Data Flow Task\Lookup.Outputs
        [Lookup Match Output].Columns[EmailPromotion]"
        name="EmailPromotion"
        truncationRowDisposition="FailComponent">
    <properties>
        <property
            dataType="System.String"
description="Specifies the column in the reference table from which
a column is copied."
            name="CopyFromReferenceColumn">EmailPromotion</property>
    </properties>
    </outputColumn>
    <outputColumn
        refId="Package\Data Flow Task\Lookup.Outputs
        [Lookup Match Output].Columns[Phone]"
        dataType="wstr"
        errorOrTruncationOperation="Copy Column"
        length="25"
        lineageId="Package\Data Flow Task\Lookup.Outputs
        [Lookup Match Output].Columns[Phone]"
        name="Phone"
        truncationRowDisposition="FailComponent">
    <properties>
        <property
            dataType="System.String"
description="Specifies the column in the reference table
from which a column is copied."
            name="CopyFromReferenceColumn">Phone</property>
    </properties>
    </outputColumn>
    <outputColumn
        refId="Package\Data Flow Task\Lookup.Outputs
        [Lookup Match Output].Columns[PasswordHash]"
        codePage="1252"

```

```

        dataType="str"
        errorOrTruncationOperation="Copy Column"
        length="128"
        lineageId="Package\Data Flow Task\Lookup.Outputs
[Lookup Match Output].Columns[PasswordHash]"
        name="PasswordHash"
        truncationRowDisposition="FailComponent">
<properties>
    <property
        dataType="System.String"
description="Specifies the column in the reference table
from which a column is copied."
        name="CopyFromReferenceColumn">PasswordHash</property>
    </properties>
</outputColumn>
<outputColumn
    refId="Package\Data Flow Task\Lookup.Outputs
[Lookup Match Output].Columns[PasswordSalt]"
    codePage="1252"
    dataType="str"
    errorOrTruncationOperation="Copy Column"
    length="10"
    lineageId="Package\Data Flow Task\Lookup.Outputs
[Lookup Match Output].Columns[PasswordSalt]"
    name="PasswordSalt"
    truncationRowDisposition="FailComponent">
<properties>
    <property
        dataType="System.String"
description="Specifies the column in the reference table
from which a column is copied."
        name="CopyFromReferenceColumn">PasswordSalt</property>
    </properties>
</outputColumn>
<outputColumn
    refId="Package\Data Flow Task\Lookup.Outputs
[Lookup Match Output].Columns[AdditionalContactInfo]"
    dataType="nText"
    errorOrTruncationOperation="Copy Column"
    lineageId="Package\Data Flow Task\Lookup.Outputs
[Lookup Match Output].Columns[AdditionalContactInfo]"
    name="AdditionalContactInfo"
    truncationRowDisposition="FailComponent">
<properties>
    <property
        dataType="System.String"
description="Specifies the column in the reference table
from which a column is copied."
        name="CopyFromReferenceColumn">AdditionalContactInfo</property>
    </properties>
</outputColumn>
<outputColumn
    refId="Package\Data Flow Task\Lookup.Outputs
[Lookup Match Output].Columns[rowguid]"
    dataType="guid"
    errorOrTruncationOperation="Copy Column"
    lineageId="Package\Data Flow Task\Lookup.Outputs
[Lookup Match Output].Columns[rowguid]"
    name="rowguid"

```

```

        truncationRowDisposition="FailComponent">
        <properties>
            <property
                dataType="System.String"
description="Specifies the column in the reference table
from which a column is copied."
                name="CopyFromReferenceColumn">rowguid</property>
            </properties>
        </outputColumn>
        <outputColumn
            refId="Package\Data Flow Task\Lookup.Outputs
[Lookup Match Output].Columns[ModifiedDate]"
            dataType="dbTimeStamp"
            errorOrTruncationOperation="Copy Column"
            lineageId="Package\Data Flow Task\Lookup.Outputs
[Lookup Match Output].Columns[ModifiedDate]"
            name="ModifiedDate"
            truncationRowDisposition="FailComponent">
        <properties>
            <property
                dataType="System.String"
description="Specifies the column in the reference table
from which a column is copied."
                name="CopyFromReferenceColumn">ModifiedDate</property>
            </properties>
        </outputColumn>
    </outputColumns>
    <externalMetadataColumns />
</output>
<output
    refId="Package\Data Flow Task\Lookup.Outputs
[Lookup No Match Output]"
description="The Lookup output that handles rows with no matching entries
in the reference dataset. Use this output when the NoMatchBehavior
property is set to "Send rows with no matching entries to the no
match output.""
    exclusionGroup="1"
    name="Lookup No Match Output"
    synchronousInputId="Package\Data Flow Task\Lookup.Inputs[Lookup Input]">
    <externalMetadataColumns />
</output>
<output
    refId="Package\Data Flow Task\Lookup.Outputs[Lookup Error Output]"
    exclusionGroup="1"
    isErrorOut="true"
    name="Lookup Error Output"
    synchronousInputId="Package\Data Flow Task\Lookup.Inputs[Lookup Input]">
    <outputColumns>
        <outputColumn
            refId="Package\Data Flow Task\Lookup.Outputs
[Lookup Error Output].Columns[ErrorCode]"
            dataType="i4"
            lineageId="Package\Data Flow Task\Lookup.Outputs
[Lookup Error Output].Columns[ErrorCode]"
            name="ErrorCode"
            specialFlags="1" />
        <outputColumn
            refId="Package\Data Flow Task\Lookup.Outputs
[Lookup Error Output].Columns[ErrorColumn]"

```

```

        dataType="i4"
        lineageId="Package\Data Flow Task\Lookup.Outputs
[Lookup Error Output].Columns[ErrorColumn]"
        name="ErrorColumn"
        specialFlags="2" />
    </outputColumns>
    <externalMetadataColumns />
</output>
</outputs>
</component>
<component
    refId="Package\Data Flow Task\Multicast"
    componentClassID="{EC139FBC-694E-490B-8EA7-35690FB0F445}"
    contactInfo="Multicast;Microsoft Corporation;Microsoft
SqlServer v9; (C) 2005 Microsoft Corporation; All Rights
Reserved; http://www.microsoft.com/sql/support;0"
    description="Creates copies of a dataset."
    name="Multicast">
    <inputs>
    <input
refId="Package\Data Flow Task\Multicast.Inputs[Multicast Input 1]"
        name="Multicast Input 1">
        <externalMetadataColumns />
    </input>
    </inputs>
    <outputs>
    <output
        refId="Package\Data Flow Task\Multicast.Outputs
[Multicast Output 1]"
        dangling="true"
        deleteOutputOnPathDetached="true"
        name="Multicast Output 1"
        synchronousInputId="Package\Data Flow Task\Multicast.
Inputs[Multicast Input 1]">
        <externalMetadataColumns />
    </output>
    </outputs>
</component>
<component
    refId="Package\Data Flow Task\Multicast 1"
    componentClassID="{EC139FBC-694E-490B-8EA7-35690FB0F445}"
    contactInfo="Multicast;Microsoft Corporation;Microsoft
SqlServer v9; (C) 2005 Microsoft Corporation; All Rights
Reserved; http://www.microsoft.com/sql/support;0"
    description="Creates copies of a dataset."
    name="Multicast 1">
    <inputs>
    <input
refId="Package\Data Flow Task\Multicast 1.Inputs[Multicast Input 1]"
        name="Multicast Input 1">
        <externalMetadataColumns />
    </input>
    </inputs>
    <outputs>
    <output
refId="Package\Data Flow Task\Multicast 1.Outputs[Multicast Output 2]"
        dangling="true"
        deleteOutputOnPathDetached="true"
        name="Multicast Output 2"

```

```

        synchronousInputId=
"Package\Data Flow Task\Multicast 1.Inputs[Multicast Input 1]">
    <externalMetadataColumns />
    </output>
</outputs>
</component>
<component
    refId="Package\Data Flow Task\New Contact Names"
    componentClassID="{D23FD76B-F51D-420F-BBCB-19CBF6AC1AB4}"
    contactInfo="Flat File Source;Microsoft Corporation;Microsoft
    SqlServer v9; (C) 2005 Microsoft Corporation; All Rights
    Reserved; http://www.microsoft.com/sql/support;1"
description="Flat File Source"
    localeId="1033"
    name="New Contact Names"
    usesDispositions="true"
    version="1">
    <properties>
        <property
            dataType="System.Boolean"
description="Specifies whether zero-length columns are treated as null."
            name="RetainNulls">false</property>
        <property
            dataType="System.String"
description="Specifies the name of an output column containing
            the file name. If no name is specified, no output column containing
            the file name will be generated."
            name="FileNameColumnName"></property>
    </properties>
    <connections>
        <connection
refId="Package\Data Flow Task\New Contact Names.
Connections[FlatFileConnection]"
            connectionManagerID="Package.ConnectionManagers[New Contacts]"
            name="FlatFileConnection" />
    </connections>
    <outputs>
        <output
            refId="Package\Data Flow Task\New Contact Names.
            Outputs[Flat File Source Output]"
            name="Flat File Source Output">
            <outputColumns>
                <outputColumn
                    refId="Package\Data Flow Task\New Contact Names.
                    Outputs[Flat File Source Output].Columns[FirstName]"
                    dataType="wstr"
                    errorOrTruncationOperation="Conversion"
                    errorRowDisposition="FailComponent"
                    externalMetadataColumnId="Package\Data Flow Task\
                    New Contact Names.Outputs[Flat File Source Output]
                    .ExternalColumns[FirstName]"
                    length="50"
                    lineageId="Package\Data Flow Task\New Contact Names.
                    Outputs[Flat File Source Output].Columns[FirstName]"
                    name="FirstName"
                    truncationRowDisposition="FailComponent">
                    <properties>
                        <property
                            dataType="System.Boolean"

```

```

description="Indicates whether the column uses the faster,
locale-neutral parsing routines."
    name="FastParse">false</property>
  </properties>
</outputColumn>
<outputColumn
  refId="Package\Data Flow Task\New Contact Names.
  Outputs[Flat File Source Output].Columns[LastName]"
  dataType="wstr"
  errorOrTruncationOperation="Conversion"
  errorRowDisposition="FailComponent"
  externalMetadataColumnId="Package\Data Flow Task\
  New Contact Names.Outputs[Flat File Source Output].
  ExternalColumns[LastName]"
  length="50"
  lineageId="Package\Data Flow Task\New Contact Names.
  Outputs[Flat File Source Output].Columns[LastName]"
  name="LastName"
  truncationRowDisposition="FailComponent">
  <properties>
    <property
      dataType="System.Boolean"
description="Indicates whether the column uses the faster,
locale-neutral parsing routines."
      name="FastParse">false</property>
    </properties>
  </outputColumn>
</outputColumns>
<externalMetadataColumns
  isUsed="True">
  <externalMetadataColumn
  refId="Package\Data Flow Task\New Contact Names.Outputs
  [Flat File Source Output].ExternalColumns[FirstName]"
    codePage="1252"
    dataType="str"
    length="50"
    name="FirstName" />
  <externalMetadataColumn
  refId="Package\Data Flow Task\New Contact Names.Outputs
  [Flat File Source Output].ExternalColumns[LastName]"
    codePage="1252"
    dataType="str"
    length="50"
    name="LastName" />
  </externalMetadataColumns>
</output>
<output
  refId="Package\Data Flow Task\New Contact Names.Outputs
  [Flat File Source Error Output]"
  isErrorOut="true"
  name="Flat File Source Error Output">
  <outputColumns>
    <outputColumn
      refId="Package\Data Flow Task\New Contact
      Names.Outputs[Flat File Source Error Output].
      Columns[Flat File Source Error Output Column]"
      codePage="1252"
      dataType="text"
      description="Flat File Source Error Output Column"

```

```

        lineageId="Package\Data Flow Task\New Contact Names.
        Outputs[Flat File Source Error Output].Columns
        [Flat File Source Error Output Column]"
        name="Flat File Source Error Output Column" />
    <outputColumn
        refId="Package\Data Flow Task\New Contact Names.Outputs
        [Flat File Source Error Output].Columns[ErrorCode]"
        dataType="i4"
        lineageId="Package\Data Flow Task\New Contact Names.
        Outputs[Flat File Source Error Output].Columns[ErrorCode]"
        name="ErrorCode"
        specialFlags="1" />
    <outputColumn
refId="Package\Data Flow Task\New Contact Names.Outputs
[Flat File Source Error Output].Columns[ErrorColumn]"
        dataType="i4"
lineageId="Package\Data Flow Task\New Contact Names.Outputs
[Flat File Source Error Output].Columns[ErrorColumn]"
        name="ErrorColumn"
        specialFlags="2" />
    </outputColumns>
    <externalMetadataColumns />
</output>
</outputs>
</component>
</components>
<paths>
    <path
        refId="Package\Data Flow Task.Paths[Flat File Source Output]"
        endId="Package\Data Flow Task\Lookup.Inputs[Lookup Input]"
        name="Flat File Source Output"
startId="Package\Data Flow Task\New Contact Names.Outputs
[Flat File Source Output]" />
    <path
        refId="Package\Data Flow Task.Paths[Fuzzy Lookup Output]"
        endId="Package\Data Flow Task\Multicast 1.Inputs
        [Multicast Input 1]"
        name="Fuzzy Lookup Output"
        startId="Package\Data Flow Task\Fuzzy Lookup.Outputs
        [Fuzzy Lookup Output]" />
    <path
        refId="Package\Data Flow Task.Paths[Lookup Error Output]"
        endId="Package\Data Flow Task\Fuzzy Lookup.Inputs
        [Fuzzy Lookup Input]"
        name="Lookup Error Output"
        startId="Package\Data Flow Task\Lookup.Outputs
        [Lookup Error Output]" />
    <path
        refId="Package\Data Flow Task.Paths[Lookup Output]"
        endId="Package\Data Flow Task\Multicast.Inputs
        [Multicast Input 1]"
        name="Lookup Output"
        startId="Package\Data Flow Task\Lookup.Outputs
        [Lookup Match Output]" />
</paths>
</pipeline>
</DTS:ObjectData>
</DTS:Executable>
</DTS:Executables>

```

```

<DTS:DesignTimeProperties><![CDATA[<?xml version="1.0"?>
<!--This CDATA section contains the layout information of the package.
The section includes information such as (x,y) coordinates, width, and
height.-->
<!--If you manually edit this section and make a mistake, you can
delete it. -->
<!--The package will still be able to load normally but the previous
layout information will be lost and the designer will automatically
re-arrange the elements on the design surface.-->
<Objects
  Version="sql11">
  <!--Each node below will contain properties that do not affect
runtime behavior.-->
  <Package
    design-time-name="Package">
    <LayoutInfo>
      <GraphLayout
        Capacity="4" xmlns="clr-namespace:Microsoft.SqlServer.
IntegrationServices.Designer.Model.
Serialization;assembly=Microsoft.SqlServer.
IntegrationServices.Graph">
        <NodeLayout
          Size="165.735849056604,43.9245283018868"
          Id="Package\Data Flow Task"
          TopLeft="5.5,5.5" />
        </GraphLayout>
      </LayoutInfo>
    </Package>
  </Objects>]]></DTS:DesignTimeProperties>
</DTS:Executable>

```

3.2 Example of Web Service Task and Script Task

The following example is taken from [Haselden], with modifications.

The following package file illustrates a Web Service Task executable that draws stock quotes from a quote system and a Script Task executable that displays the result. The package file also contains a **PrecedenceConstraint** operation that describes the relationship between the two tasks. The Microsoft® SQL Server® Integration Services (SSIS) user interface in the designer that represents this package example is shown in the following diagram.

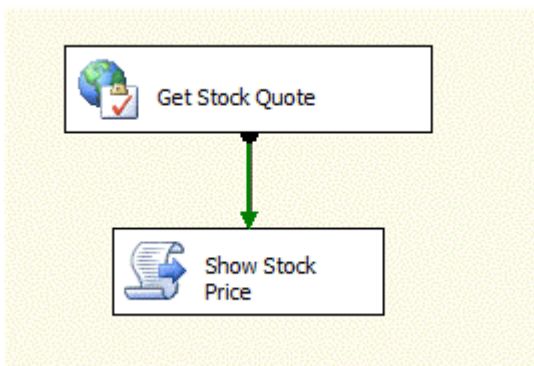

Figure 4: Web Service Task executable and the Script Task in Integration Services user interface

The Script Task executable in this package file is an example of how custom user code is stored in a package file. In the Script Task executable, the **ObjectData** element contains a **ScriptProject** element. Within the **ScriptProject** element is a collection of **ProjectItem** elements, each of which contains Visual Basic source code for the script project. Also within the **ScriptProject** element is a **BinaryItem** element, which contains the compiled source code for this project, encoded as type **xs:base64binary**.

```
<?xml version="1.0"?>
<DTS:Executable xmlns:DTS="www.microsoft.com/SqlServer/Dts"
  DTS:refId="Package"
  DTS:CreationDate="7/16/2005 3:59:24 PM"
  DTS:CreationName="SSIS.Package.3"
  DTS:CreatorComputerName="ROMEO"
  DTS:CreatorName="Kirk Haselden"
  DTS:DTSID="{6BC04190-25CC-422A-92BE-68ACBD6F59E8}"
  DTS:EnableConfig="True"
  DTS:ExecutableType="SSIS.Package.3"
  DTS:ExecValue="0"
  DTS:ExecValueType="3"
  DTS:LastModifiedProductVersion="11.0.1153.1"
  DTS:LocaleID="1033"
  DTS:ObjectName="WebService"
  DTS:PackageType="5"
  DTS:ProtectionLevel="0"
  DTS:VersionBuild="117"
  DTS:VersionGUID="{57687733-19AA-4974-9B56-5BEB6BD40E11}">
  <DTS:Property
    DTS:Name="PackageFormatVersion">6</DTS:Property>
  <DTS:ConnectionManagers>
    <DTS:ConnectionManager
      DTS:refId="Package.ConnectionManagers[cmService]"
      DTS:CreationName="HTTP"
      DTS:DTSID="{2DA145FD-9C6E-487D-9A50-DD97C1D11763}"
      DTS:ObjectName="cmService">
      <DTS:ObjectData>
        <DTS:ConnectionManager
          DTS:ConnectionString="http://www.ecubicle.net/livestockquotes.asmx?WSDL">
          <DTS:HttpConnection
            DTS:ServerURL="http://www.ecubicle.net/livestockquotes.asmx?WSDL">
            <DTS:Property
              DTS:Name="ServerPassword"
              Sensitive="1"></DTS:Property>
            <DTS:Property
              DTS:Name="ProxyPassword"
              Sensitive="1"></DTS:Property>
            </DTS:HttpConnection>
          </DTS:ConnectionManager>
        </DTS:ObjectData>
      </DTS:ConnectionManager>
    <DTS:ConnectionManager
      DTS:refId="Package.ConnectionManagers[foo]"
      DTS:CreationName="FILE"
      DTS:DTSID="{C5C2675C-13D7-4DED-B499-9F45AA97C32A}"
      DTS:ObjectName="foo">
      <DTS:ObjectData>
        <DTS:ConnectionManager
          DTS:FileUsageType="1"

```

```

        DTS:ConnectionString="foo" />
    </DTS:ObjectData>
</DTS:ConnectionManager>
</DTS:ConnectionManagers>
<DTS:Configurations>
  <DTS:Configuration
    DTS:ConfigurationString="SSISSAMPLESROOT"
    DTS:ConfigurationType="2"
    DTS:ConfigurationVariable="\Package.Variables[SAMPLES::ROOTWD].
    Properties[Value]"
    DTS:CreationName=""
    DTS:DTSID="{90405045-3A91-43C2-B759-6C183C0E81A6}"
    DTS:ObjectName="Configure The Root Folder" />
  <DTS:Configuration
    DTS:ConfigurationString="SSISSAMPLESERVER"
    DTS:ConfigurationType="2"
    DTS:ConfigurationVariable="\Package.Variables[SAMPLES::SERVERNAME].
    Properties[Value]"
    DTS:CreationName=""
    DTS:DTSID="{A9F64F24-15C2-4198-A308-F9124C48468D}"
    DTS:ObjectName="Configure The Sample Server Name" />
</DTS:Configurations>
<DTS:Variables>
  <DTS:Variable
    DTS:CreationName=""
    DTS:DTSID="{E05C4384-FA46-4EDB-9E41-E0CDD6DD4DC6}"
    DTS:EvaluateAsExpression="True"
    DTS:Expression="@ROOTWD + &quot;\\&quot; + @SAMPLESUBFOLDER"
    DTS:IncludeInDebugDump="2345"
    DTS:Namespace="SAMPLES"
    DTS:ObjectName="CURRENTWD">
    <DTS:VariableValue
      DTS:DataType="8">C:\USERS\V-TOMCON.REDMOND\MY DOCUMENTS\SSIS\
      BOOKSAMPLES2005\S08-StockTasks</DTS:VariableValue>
    </DTS:Variable>
  <DTS:Variable
    DTS:CreationName=""
    DTS:DTSID="{3BD365BA-FE06-4B5A-8100-69F27C71B74E}"
    DTS:IncludeInDebugDump="2345"
    DTS:Namespace="SAMPLES"
    DTS:ObjectName="ROOTWD">
    <DTS:VariableValue
      DTS:DataType="8">C:\USERS\V-TOMCON.REDMOND\MY DOCUMENTS\SSIS\
      BOOKSAMPLES2005</DTS:VariableValue>
    </DTS:Variable>
  <DTS:Variable
    DTS:CreationName=""
    DTS:DTSID="{6E7FB8C5-7F98-454E-87E0-D9BF0D0E06AD}"
    DTS:IncludeInDebugDump="2345"
    DTS:Namespace="SAMPLES"
    DTS:ObjectName="SAMPLESUBFOLDER">
    <DTS:VariableValue
      DTS:DataType="8">S08-StockTasks</DTS:VariableValue>
    </DTS:Variable>
  <DTS:Variable
    DTS:CreationName=""
    DTS:DTSID="{5F9998D0-186D-4C44-A949-66C8477A3CE7}"
    DTS:IncludeInDebugDump="2345"
    DTS:Namespace="SAMPLES"

```

```

    DTS:ObjectName="SERVERNAME">
    <DTS:VariableValue
      DTS:DataType="8">.</DTS:VariableValue>
    </DTS:Variable>
  <DTS:Variable
    DTS:CreationName=""
    DTS:DTSID="{E084171E-93C0-43BC-BC6C-83833B78109E}"
    DTS:IncludeInDebugDump="2345"
    DTS:Namespace="SAMPLES"
    DTS:ObjectName="STOCKQUOTE">
    <DTS:VariableValue
      DTS:DataType="8"></DTS:VariableValue>
    </DTS:Variable>
  <DTS:Variable
    DTS:CreationName=""
    DTS:DTSID="{58589E35-3D84-4D07-8A32-A75E6591D7F0}"
    DTS:IncludeInDebugDump="2345"
    DTS:Namespace="SAMPLES"
    DTS:ObjectName="TICKERSYMBOL">
    <DTS:VariableValue
      DTS:DataType="8">MSFT</DTS:VariableValue>
    </DTS:Variable>
</DTS:Variables>
<DTS:Executables>
  <DTS:Executable
    DTS:refId="Package\Get Stock Quote"
    DTS:CreationName="Microsoft.SqlServer.Dts.Tasks.WebServiceTask.
WebServiceTask, Microsoft.SqlServer.WebServiceTask,
Version=11.0.0.0, Culture=neutral, PublicKeyToken=89845dcd8080cc91"
    DTS:Description="Web Service Task"
    DTS:DTSID="{6CA7FC7C-AB58-4C39-BD00-3F22B51AAB92}"
    DTS:ExecutableType="Microsoft.SqlServer.Dts.Tasks.WebServiceTask.
WebServiceTask, Microsoft.SqlServer.WebServiceTask, Version=11.0.0.0,
Culture=neutral, PublicKeyToken=89845dcd8080cc91"
    DTS:ExecValue="0"
    DTS:ExecValueType="3"
    DTS:LocaleID="-1"
    DTS:ObjectName="Get Stock Quote"
    DTS:TaskContact="Web Service Task; Microsoft Corporation; Microsoft
SQL Server v9; © 2004 Microsoft Corporation; All Rights Reserved;
http://www.microsoft.com/sql/support/default.asp;1"
    DTS:ThreadHint="0">
    <DTS:Variables />
    <DTS:PropertyExpression
      DTS:Name="WSDLFile">@[SAMPLES::ROOTWD] + "\\SampleData\Service.wsdl"
    </DTS:PropertyExpression>
    <DTS:ObjectData>
      <WSTask:WebServiceTaskData
        WSTask:ConnectionName="{2DA145FD-9C6E-487D-9A50-DD97C1D11763}"
        WSTask:Service="LiveStockQuotes"
        WSTask:WSDLFile="C:\USERS\V-TOMCON.REDMOND\MY DOCUMENTS\SSIS\
BOOKSAMPLES2005\SampleData\Service.wsdl"
        WSTask:OverwriteWSDLFile="True"
        WSTask:OutputLocation="foo" xmlns:WSTask="www.microsoft.com/
sqlserver/dts/tasks/webservicetask">
        <WSTask:MethodInfo
          WSTask:MethodName="liveMarketAsString"
          WSTask:MessageName="LiveMarketAsString">
          <WSTask:Documentation>&lt;h3&gt;This method can be used

```

```

        if a consumer is unable to consume liveMarket method. The
        returned data is XML string.&lt;/h3&gt;
    </WSTask:Documentation>
    <WSTask:ParamInfo
        WSTask:Name="stockSymbol"
        WSTask:Datatype="string"
        WSTask:ParamType="Primitive"
        WSTask:SeqNumber="0">
        <WSTask:PrimitiveValue></WSTask:PrimitiveValue>
    </WSTask:ParamInfo>
    </WSTask:MethodInfo>
</WSTask:WebServiceTaskData>
</DTS:ObjectData>
</DTS:Executable>
<DTS:Executable
    DTS:refId="Package\Show Stock Price"
    DTS:CreationName="Microsoft.SqlServer.Dts.Tasks.ScriptTask.ScriptTask,
    Microsoft.SqlServer.ScriptTask, Version=11.0.0.0, Culture=neutral,
    PublicKeyToken=89845dcd8080cc91"
    DTS:Description="Script Task"
    DTS:DTSID="{325ba39d-e3ab-46cc-8f27-c28e9a5f9f8f}"
    DTS:ExecutableType="Microsoft.SqlServer.Dts.Tasks.ScriptTask.
    ScriptTask, Microsoft.SqlServer.ScriptTask, Version=11.0.0.0,
    Culture=neutral, PublicKeyToken=89845dcd8080cc91"
    DTS:ExecValue="0"
    DTS:ExecValueType="3"
    DTS:LocaleID="-1"
    DTS:ObjectName="Show Stock Price"
    DTS:ThreadHint="0">
    <DTS:Variables />
    <DTS:ObjectData>
        <ScriptProject
            Name="ScriptTask_053aaalde6d84acab80050be0c42b6f2"
            VSTAMajorVersion="2"
            VSTAMinorVersion="2"
            Language="VisualBasic"
            ReadOnlyVariables="SAMPLES::STOCKQUOTE, SAMPLES::TICKERSYMBOL">
            <ProjectItem
                Name="\my project\assemblyinfo.vb"><![CDATA[Imports System
Imports System.Reflection
Imports System.Runtime.InteropServices
' General Information about an assembly is controlled through the following
' set of attributes. Change these attribute values to modify the information
' associated with an assembly.
' Review the values of the assembly attributes
<Assembly: AssemblyTitle("ScriptTask_053aaalde6d84acab80050be0c42b6f2.vbproj")>
<Assembly: AssemblyDescription("")>
<Assembly: AssemblyCompany("MSIT")>
<Assembly: AssemblyProduct("ScriptTask_053aaalde6d84acab80050be0c42b6f2.vbproj")>
<Assembly: AssemblyCopyright("Copyright @ MSIT 2008")>
<Assembly: AssemblyTrademark("")>
<Assembly: CLSCompliant(True)>
<Assembly: ComVisible(False)>
' The following GUID is for the ID of the typelib if this project is exposed to COM
<Assembly: Guid("e54931f7-e817-4314-a409-3cdc9702928a")>
' Version information for an assembly consists of the following four values:
'
'     Major Version
'     Minor Version

```

```

'      Build Number
'      Revision
'
' You can specify all the values or you can default the Build and Revision Numbers
' by using the '*' as shown below:
' <Assembly: AssemblyVersion("1.0.*")>
<Assembly: AssemblyVersion("1.0.0.0")>
<Assembly: AssemblyFileVersion("1.0.0.0")> ]]></ProjectItem>
  <ProjectItem
    Name="\my project\settings.designer.vb"><![CDATA['-----
-----
' <autogenerated>
'   This code was generated by a tool.
'
'   Changes to this file may cause incorrect behavior and will be lost if
'   the code is regenerated.
' </autogenerated>
-----
Option Strict Off
Option Explicit On
Partial Friend NotInheritable Class MySettings
  Inherits System.Configuration.ApplicationSettingsBase
  Private Shared m_Value As MySettings
  Private Shared m_SyncObject As Object = New Object
  <System.Diagnostics.DebuggerNonUserCode()> _
  Public Shared ReadOnly Property Value() As MySettings
    Get
      If (MySettings.m_Value Is Nothing) Then
        System.Threading.Monitor.Enter(MySettings.m_SyncObject)
        If (MySettings.m_Value Is Nothing) Then
          Try
            MySettings.m_Value = New MySettings
          Finally
            System.Threading.Monitor.Exit(MySettings.m_SyncObject)
          End Try
        End If
      End If
      Return MySettings.m_Value
    End Get
  End Property
End Class]]></ProjectItem>
  <ProjectItem
    Name="\scripttask_053aaalde6d84acab80050be0c42b6f2.vbproj">
    <![CDATA[<Project ToolsVersion="3.5" DefaultTargets="Build"
      xmlns="http://schemas.microsoft.com/developer/msbuild/2003">
<!-- This section defines project-level properties.
Configuration - Specifies whether the default
configuration is Release or Debug.
Platform - Specifies what CPU the output of this project can
run on.
OutputType - Must be "Library" for VSTA.
NoStandardLibraries - Set to "false" for VSTA.
RootNamespace - In C#, this specifies the namespace given to
new files.

      In Visual Basic, all objects are wrapped in
      this namespace at runtime.
AssemblyName - Name of the output assembly.
-->
<PropertyGroup>

```

```

<ProjectTypeGuids>{A860303F-1F3F-4691-B57E-529FC101A107};
{F184B08F-C81C-45F6-A57F-5ABD9991F28F}</ProjectTypeGuids>
<Configuration Condition=" '$(Configuration)' == ' ' ">Debug
</Configuration>
<Platform Condition=" '$(Platform)' == ' ' ">AnyCPU</Platform>
<OutputType>Library</OutputType>
<RootNamespace>ScriptTask_053aaa1de6d84acab80050be0c42b6f2.vbproj
</RootNamespace>
<AssemblyName>ScriptTask_053aaa1de6d84acab80050be0c42b6f2.vbproj
</AssemblyName>
<StartupObject>
</StartupObject>
<OptionExplicit>On</OptionExplicit>
<OptionCompare>Binary</OptionCompare>
<OptionStrict>Off</OptionStrict>
<OptionInfer>On</OptionInfer>
<ProjectGuid>{EB2B3188-9A8D-427A-988F-48D11FE940F1}</ProjectGuid>
</PropertyGroup>
<!-- This section defines properties that are set when the "Debug"
configuration is
selected.
DebugSymbols - If true, create symbols (.pdb). If false, do not
create symbols.
Optimize - If true, optimize the build output. If false, do
not optimize.
OutputPath - Output path of the project relative to the
project file.
EnableUnmanagedDebugging - If true, starting the debugger
will attach both managed and unmanaged debuggers.
DefineConstants - Constants defined for the preprocessor.
Warning Level - Warning level for the compiler.
-->
<PropertyGroup Condition=" '$(Configuration)' == 'Debug' ">
<DefineConstants>
</DefineConstants>
<DefineDebug>true</DefineDebug>
<DefineTrace>true</DefineTrace>
<DebugSymbols>true</DebugSymbols>
<Optimize>false</Optimize>
<OutputPath>bin</OutputPath>
<RegisterForComInterop>false</RegisterForComInterop>
<RemoveIntegerChecks>false</RemoveIntegerChecks>
<NoWarn>42016,42017,42018,42019,42032</NoWarn>
</PropertyGroup>
<!-- This section defines properties that are set when the "Release"
configuration is
selected.
DebugSymbols - If true, create symbols (.pdb). If false,
do not create symbols.
Optimize - If true, optimize the build output. If false,
do not optimize.
OutputPath - Output path of the project relative to the
project file.
EnableUnmanagedDebugging - If true, starting the debugger will
attach both managed and unmanaged debuggers.
DefineConstants - Constants defined for the preprocessor.
Warning Level - Warning level for the compiler.
-->
<PropertyGroup Condition=" '$(Configuration)' == 'Release' ">

```

```

    <DefineConstants>
  </DefineConstants>
  <DefineDebug>false</DefineDebug>
  <DefineTrace>true</DefineTrace>
  <DebugSymbols>false</DebugSymbols>
  <Optimize>true</Optimize>
  <OutputPath>bin\</OutputPath>
  <RegisterForComInterop>false</RegisterForComInterop>
  <RemoveIntegerChecks>false</RemoveIntegerChecks>
  <NoWarn>42016,42017,42018,42019,42032</NoWarn>
</PropertyGroup>
<!-- This section enables pre- and post-build steps. However,
      it is recommended that MSBuild tasks be used instead of these
      properties.
-->
-->
<PropertyGroup>
  <PreBuildEvent>
  </PreBuildEvent>
  <PostBuildEvent>
  </PostBuildEvent>
</PropertyGroup>
<!-- This sections specifies references for the project. -->
<ItemGroup>
  <Reference Include="Microsoft.SqlServer.ManagedDTS,
    Version=11.0.0.0, Culture=neutral,
    PublicKeyToken=89845dcd8080cc91" />
  <Reference Include="Microsoft.SqlServer.ScriptTask,
    Version=11.0.0.0, Culture=neutral,
    PublicKeyToken=89845dcd8080cc91" />
  <Reference Include="System" />
  <Reference Include="System.AddIn,
    Version=3.5.0.0, Culture=neutral, PublicKeyToken=b77a5c561934e089,
    processorArchitecture=MSIL" />
  <Reference Include="System.Data" />
  <Reference Include="System.Windows.Forms" />
  <Reference Include="System.Xml" />
</ItemGroup>
<!-- Visual Basic supports Importing namespaces
(equivalent to using statements in C#).-->
<ItemGroup>
  <Import Include="Microsoft.VisualBasic" />
  <Import Include="System" />
  <Import Include="System.Collections" />
  <Import Include="System.Data" />
  <Import Include="System.Diagnostics" />
  <Import Include="System.Windows.Forms" />
</ItemGroup>
<!-- This section defines the user source files that are part of the
project.
Compile - Specifies a source file to compile.
EmbeddedResource - Specifies a .resx file for embedded resources.
None - Specifies a file that is not to be passed to the compiler
(for instance,
      a text file or XML file).
AppDesigner - Specifies the directory where the application
properties files can
      be found.
-->
-->
<ItemGroup>

```

```

<AppDesigner Include="My Project\" />
<Compile Include="My Project\AssemblyInfo.vb">
  <SubType>Code</SubType>
</Compile>
<EmbeddedResource Include="My Project\Resources.resx">
  <Generator>VbMyResourcesResXFileCodeGenerator</Generator>
  <LastGenOutput>Resources.Designer.vb</LastGenOutput>
  <CustomToolNamespace>My.Resources</CustomToolNamespace>
</EmbeddedResource>
<Compile Include="My Project\Resources.Designer.vb">
  <AutoGen>True</AutoGen>
  <DesignTime>True</DesignTime>
  <DependentUpon>Resources.resx</DependentUpon>
  <SubType>Code</SubType>
</Compile>
<None Include="My Project\Settings.settings">
  <Generator>SettingsSingleFileGenerator</Generator>
  <LastGenOutput>Settings.Designer.vb</LastGenOutput>
</None>
<Compile Include="My Project\Settings.Designer.vb">
  <AutoGen>True</AutoGen>
  <DependentUpon>Settings.settings</DependentUpon>
  <SubType>Code</SubType>
</Compile>
<Compile Include="ScriptMain.designer.vb">
  <DependentUpon>ScriptMain.Designer.xml</DependentUpon>
</Compile>
<Compile Include="ScriptMain.vb">
  <SubType>Code</SubType>
</Compile>
<None Include="ScriptMain.Designer.xml">
  <DependentUpon>ScriptMain.vb</DependentUpon>
</None>
<!-- Include the default configuration information and metadata
files for the add-in.
    These files are copied to the build output directory when
    the project is
    built, and the path to the configuration file is passed to
    add-in on the command
    line when debugging.
-->
</ItemGroup>
<!-- Include the build rules for a VB project.-->
<Import Project="$(MSBuildBinPath)\Microsoft.VisualBasic.targets" />
<!-- This section defines VSTA properties that describe the host-
changable project properties. -->
<ProjectExtensions>
  <VisualStudio>
    <FlavorProperties GUID="{A860303F-1F3F-4691-B57E-529FC101A107}">
      <ProjectProperties HostName="VSTAHostName" HostPackage=
        "{C1B21C64-9E6F-4923-A89D-9F958503C1CE}" ApplicationType="usd"
        Language="vb" TemplatesPath="" DebugInfoExeName=
        "#HKEY_LOCAL_MACHINE\SOFTWARE\Microsoft\VisualStudio\9.0\
        InstallDir#devenv.exe" />
      <Host Name="SSIS_ScriptTask">
        <HostItem Name="ScriptMain" Code="ScriptMain.vb"
          CanonicalName="ScriptMain" DisplayName="ScriptMain"
          Blueprint="ScriptMain.Designer.xml" GeneratedCode=
          "ScriptMain.designer.vb" />
      </Host>
    </FlavorProperties>
  </VisualStudio>
</ProjectExtensions>

```



```

    </Host>
    <ProjectClient>
      <HostIdentifier>SSIS_ST110</HostIdentifier>
    </ProjectClient>
  </FlavorProperties>
</VisualStudio>
</ProjectExtensions>
</Project>]]></ProjectItem>
  <ProjectItem
    Name="\my project\settings.settings">
      <![CDATA[<?xml version='1.0' encoding='iso-8859-1'?>
<SettingsFile xmlns="uri:settings" CurrentProfile="(Default)"
GeneratedClassNamespace="$safeprojectname" GeneratedClassName="MySettings">
  <Profiles>
    <Profile Name="(Default)" />
  </Profiles>
  <Settings />
</SettingsFile>]]></ProjectItem>
  <ProjectItem
    Name="\my project\resources.designer.vb"><![CDATA['-----
' <autogenerated>
'   This code was generated by a tool.
'
'   Changes to this file may cause incorrect behavior and will be lost if
'   the code is regenerated.
' </autogenerated>
'-----
Option Strict Off
Option Explicit On
Namespace My.Resources
  '''<summary>
  '''   A strongly-typed resource class, for looking up localized strings,
  etc.
  '''</summary>
  'This class was auto-generated by the Strongly Typed Resource Builder
  'class via a tool like ResGen or Visual Studio.NET.
  'To add or remove a member, edit your .ResX file then rerun ResGen
  'with the /str option, or rebuild your VS project.
  Class MyResources
    Private Shared _resMgr As System.Resources.ResourceManager
    Private Shared _resCulture As System.Globalization.CultureInfo
    Friend Sub New()
      MyBase.New
    End Sub
    '''<summary>
    '''   Returns the cached ResourceManager instance used by this class.
    '''</summary>
    <System.ComponentModel.EditorBrowsableAttribute(System.
    ComponentModel.EditorBrowsableState.Advanced)> _
    Public Shared ReadOnly Property ResourceManager() As System.
    Resources.ResourceManager
      Get
        If (_resMgr Is Nothing) Then
          Dim temp As System.Resources.ResourceManager =
          New System.Resources.ResourceManager
          ("My.Resources.MyResources",
          GetType(MyResources).Assembly)
          _resMgr = temp

```

```

        End If
        Return _resMgr
    End Get
End Property
'''<summary>
''' Overrides the current thread's CurrentUICulture
property for all
''' resource lookups using this strongly typed resource class.
'''</summary>
<System.ComponentModel.EditorBrowsableAttribute
(System.ComponentModel.EditorBrowsableState.Advanced)> _
Public Shared Property Culture() As System.Globalization.CultureInfo
    Get
        Return _resCulture
    End Get
    Set
        _resCulture = value
    End Set
End Property
End Class
End Namespace]]></ProjectItem>
<ProjectItem
    Name="\scriptmain.designer.vb">
    <![CDATA[<System.CLSCompliantAttribute(False)> _
Partial Public Class ScriptMain
Inherits Microsoft.SqlServer.Dts.Tasks.ScriptTask.
VSTARTScriptObjectModelBase
End Class]]></ProjectItem>
<ProjectItem
    Name="\my project\resources.resx">
    <![CDATA[<?xml version="1.0" encoding="utf-8"?>
<root>
<!--
Microsoft ResX Schema
Version 2.0
The primary goals of this format is to allow a simple XML format
that is mostly human readable. The generation and parsing of the
various data types are done through the TypeConverter classes
associated with the data types.
Example:
... ado.net/XML headers & schema ...
<resheader name="resmimetype">text/microsoft-resx</resheader>
<resheader name="version">2.0</resheader>
<resheader name="reader">System.Resources.ResXResourceReader,
System.Windows.Forms, ...</resheader>
<resheader name="writer">System.Resources.ResXResourceWriter,
System.Windows.Forms, ...</resheader>
<data name="Name1"><value>this is my long string</value><comment>
this is a comment</comment></data>
<data name="Color1" type="System.Drawing.Color, System.Drawing">Blue
</data>
<data name="Bitmap1" mimetype="application/x-microsoft.net.object.
binary.base64">
    <value>[base64 mime encoded serialized .NET Framework object]
</value>
</data>
<data name="Icon1" type="System.Drawing.Icon, System.Drawing"
mimetype="application/x-microsoft.net.object.bytearray.base64">
    <value>[base64 mime encoded string representing a byte array

```

```

    form of the .NET Framework object]</value>
    <comment>This is a comment</comment>
</data>
There are any number of "resheader" rows that contain simple
name/value pairs.
Each data row contains a name, and value. The row also contains a
type or mimetype. Type corresponds to a .NET class that support
text/value conversion through the TypeConverter architecture.
Classes that don't support this are serialized and stored with the
mimetype set.
The mimetype is used for serialized objects, and tells the
ResXResourceReader how to depersist the object. This is currently not
extensible. For a given mimetype the value must be set accordingly:
Note - application/x-microsoft.net.object.binary.base64 is the format
that the ResXResourceWriter will generate, however the reader can
read any of the formats listed below.
mimetype: application/x-microsoft.net.object.binary.base64
value : The object must be serialized with
       : System.Serialization.Formatters.Binary.BinaryFormatter
       : and then encoded with base64 encoding.
mimetype: application/x-microsoft.net.object.soap.base64
value : The object must be serialized with
       : System.Runtime.Serialization.Formatters.Soap.SoapFormatter
       : and then encoded with base64 encoding.
mimetype: application/x-microsoft.net.object.bytearray.base64
value : The object must be serialized into a byte array
       : using a System.ComponentModel.TypeConverter
       : and then encoded with base64 encoding.
-->
<xsd:schema id="root" xmlns="" xmlns:xsd="http://www.w3.org/2001/XMLSchema"
xmlns:msdata="urn:schemas-microsoft-com:xml-msdata">
  <xsd:element name="root" msdata:IsDataSet="true">
    <xsd:complexType>
      <xsd:choice maxOccurs="unbounded">
        <xsd:element name="metadata">
          <xsd:complexType>
            <xsd:sequence>
              <xsd:element name="value" type="xsd:string" minOccurs="0" />
            </xsd:sequence>
            <xsd:attribute name="name" type="xsd:string" />
            <xsd:attribute name="type" type="xsd:string" />
            <xsd:attribute name="mimetype" type="xsd:string" />
          </xsd:complexType>
        </xsd:element>
        <xsd:element name="assembly">
          <xsd:complexType>
            <xsd:attribute name="alias" type="xsd:string" />
            <xsd:attribute name="name" type="xsd:string" />
          </xsd:complexType>
        </xsd:element>
        <xsd:element name="data">
          <xsd:complexType>
            <xsd:sequence>
              <xsd:element name="value" type="xsd:string"
minOccurs="0" msdata:Ordinal="1" />
              <xsd:element name="comment" type="xsd:string"
minOccurs="0" msdata:Ordinal="2" />
            </xsd:sequence>
            <xsd:attribute name="name" type="xsd:string"

```

```

        msdata:Ordinal="1" />
        <xsd:attribute name="type" type="xsd:string"
        msdata:Ordinal="3" />
        <xsd:attribute name="mimetype" type="xsd:string"
        msdata:Ordinal="4" />
    </xsd:complexType>
</xsd:element>
<xsd:element name="resheader">
    <xsd:complexType>
        <xsd:sequence>
            <xsd:element name="value" type="xsd:string"
                minOccurs="0" msdata:Ordinal="1" />
        </xsd:sequence>
        <xsd:attribute name="name" type="xsd:string" use="required" />
    </xsd:complexType>
</xsd:element>
</xsd:choice>
</xsd:complexType>
</xsd:element>
</xsd:schema>
<resheader name="resmimetype">
    <value>text/microsoft-resx</value>
</resheader>
<resheader name="version">
    <value>2.0</value>
</resheader>
<resheader name="reader">
    <value>System.Resources.ResXResourceReader, System.Windows.Forms,
        Version=2.0.0.0, Culture=neutral, PublicKeyToken=b77a5c561934e089</value>
</resheader>
<resheader name="writer">
    <value>System.Resources.ResXResourceWriter, System.Windows.Forms,
        Version=2.0.0.0, Culture=neutral, PublicKeyToken=b77a5c561934e089</value>
</resheader>
</root>]]></ProjectItem>
    <ProjectItem
        Name="\scriptmain.vb"><![CDATA[Imports System
Imports System.Data
Imports System.Math
Imports Microsoft.SqlServer.Dts.Runtime
Imports System.Xml
<System.AddIn.AddIn("ScriptMain", Version:="1.0", Publisher:="",
Description:="")> _
Partial Class ScriptMain
Private Sub ScriptMain_Startup(ByVal sender As Object, ByVal e As
    System.EventArgs)
End Sub
Private Sub ScriptMain_Shutdown(ByVal sender As Object, ByVal e As
    System.EventArgs)
Try
' Unlock variables from the read-only and read-write variable
    collection properties
If (Dts.Variables.Count <> 0) Then
Dts.Variables.Unlock()
End If
Catch ex As Exception
End Try
End Sub
Enum ScriptResults

```

```

Success = Microsoft.SqlServer.Dts.Runtime.DTSExecResult.Success
Failure = Microsoft.SqlServer.Dts.Runtime.DTSExecResult.Failure
End Enum
Public Sub Main()
    Dim last As String = New String("")
    Dim xmlDoc As XmlDocument = New XmlDocument()
    xmlDoc.LoadXml(Dts.Variables("SAMPLES::STOCKQUOTE").Value.ToString())
    If Not IsDBNull(xmlDoc) Then
        Dim list As XmlNodeList
        list = xmlDoc.DocumentElement.GetElementsByTagName("last_trade")
        If list.Count > 0 Then
            last = list.Item(0).InnerText
            MsgBox("The last price for the stock " + Dts.Variables
                ("SAMPLES::TICKERSYMBOL").Value.ToString() + ": is " +
                last.ToString(), MsgBoxStyle.OkOnly,
                "Webservices Task Sample")
            Dts.TaskResult = ScriptResults.Success
        End If
    End If
End Sub
End Class]]></ProjectItem>
<ProjectItem
    Name="\scriptmain.designer.xml">
    <![CDATA[<hostitem:hostItem hostitem:identifier="ScriptMain"
        hostitem:namespace="" hostitem:primaryCookie="ScriptMain"
        hostitem:baseType="Microsoft.SqlServer.Dts.Tasks.ScriptTask.VSTAProxy.
        VSTARTScriptObjectModelBaseEntryPoint"
        hostitem:interfaceType=
        "Microsoft.VisualStudio.Tools.Applications.
        Runtime.IEntryPoint" hostitem:displayName="ScriptMain"
        hostitem:generateCode="true" hostitem:startupIndex="0"
        xmlns:hostitem=
        "http://schemas.microsoft.com/2006/VisualStudio/Tools/Applications/
        HostItem.xsd" />]]></ProjectItem>
<BinaryItem
    Name="\bin\scripttask_053aa1de6d84acab80050be0c42b6f2.vbproj.dll">
TVqQAAMAAAAEAAAA//8AALgAAAAAAAAAQAAAAAAAAAAAAAAAAAAAAAAAAAAAAAAAA
AAAAgAAAA4fug4AtAnNIbgBTM0hVghpcyBwcm9ncmFtIGNhbm5vdCBiZSBydW4gaW4gRE9TIGlv
ZGUuDQ0KJAAAAAAAAABQRQAATAEDAKSIBk0AAAAAAAAAOAAAEIQAQgAAB4AAAAAMAAAAAAAzj0A
AAAgAAAAQAAAAABAAAQAAAAgAABAAAAAAAEAAAAAAAAACAAAAAgAAAAAAIAQIUAAABAA
ABAAAAAEAAAAEAAAAAAAAABAAAAAAAAAAAAAAHg9AABTAAAAAEAAAIGJAAAAAAAAAAAAAAAA
AAAAAGAAAAwAAAAAAAAAAAAAAAAAAAAAAAAAAAAAAAAAAAAAAAAAAAAAAAAAAAAAAAAAAAA
AAAAIAAACAAAAAAAAAAAAAAAAACAAAEgAAAAAAAAAAAAAC50ZXh0AAAA1B0AAAAgAAAAHgAAAAIA
AAAAAAAAAAAAAAAAACAAGAucNnyYwAAAIGJAAAAQAAAAAaAAAaGAAAAAAAAAAAAAAAAABAAABA
LnJlbG9jAAAMAAAAAGAAAACAAAAKgAAAAAAAAAAAAAAAAAQAAQgAAAAAAAAAAAAAAAAAAACw
PQAAAAAAAAEgAAAACAAUAgCQAAPgYAAABAAAAAAAAAFgAAC4AAAAAAAAAAAAAAAAAAAAAAAA
AAAAAAAAAAAAAAAAAAAAAAAAAAALQAAAD0yu++AQAAAJEAAABsU3lzdGVtLlJlc291cmNlcy5S
ZXNvdXJjZVJlYWRLciwgbnXNjb3JsaWIsIFZlcnNpb249Mi4wLjAuMCMwQ3VsdHVyZT1uZXV0cmFs
LCBQdWJsaWNlZX1Ub2t1bj1iNzdhNWm1NjE5MzRlMdg5I1N5c3RlbS5SZNvdXJjZXMuUnVudGlt
ZVJlc291cmNlU2V0AgAAAAAAAAAAAAUEFEUEFEULQAAAAeAigBAAAKKh4CKAQAAAoqpnMGAAGK
gAEAAARzBwAACoACAAAEcwqAAaAwAABHMAAAKGAQAAQgAAATMAEACwAAAAEABF+AQAAABG8K
AAAKKgATMAEACwAAAAIAABF+AgAABG8LAAAKKgATMAEACwAAAAAABF+AwAABG8MAAAKKgATMAEA
CwAAAAQAABF+BAAABG8NAAAKKgATMAIADQAAAAUAABECAYgRAAAKKBIAAAoqAAAAEzABAAcAAAAG
AAARaigTAAAKKgATMAEACwAAAAcAABHQBAAAigUAAAKKgATMAEABwAAAAgAABECKBUAAoqABMw
AQQAQAAACQAAEQKMAQAAGy0GKAEAAcSqAioTMAIAEAAAAAaABEDEgD+FQIAABsGgQIAABsHgIo
FwAACioTMAIAKAAAAAaABECexkAAApvGgAACGsHjAMAABstEigCAAArCwJ7GQAACgdvGwAACGcCq
SgIoFwAACGjZHAACn0ZAAAKKgAeAigXAAAKKhMwAgAtAAAADAAAEX4GAAAELSBYAQAAcNAHAAAC
KBQAAApvHgAACMfAAAKCweABgAABH4GAAAEKgAABMwAQAGAAADQAAEX4HAAAEKgAAHgKABwAA
BCpCcxcAAAoEQAACoAJAAAEKgAAB4CKCAAAoqGzABAD8AAAAOAAARfggAAQTMn4JAAAEKBEA

```



```

    </DTS:Executable>
</DTS:Executables>
<DTS:PrecedenceConstraints>
  <DTS:PrecedenceConstraint
    DTS:refId="Package.PrecedenceConstraints[Constraint 1]"
    DTS:CreationName=""
    DTS:DTSID="{F2196320-9345-4773-9EBD-06F12CDDFB06}"
    DTS:From="Package\Get Stock Quote"
    DTS:LogicalAnd="True"
    DTS:ObjectName="Constraint 1"
    DTS:To="Package\Show Stock Price" />
  </DTS:PrecedenceConstraints>
  <DTS:DesignTimeProperties><![CDATA[<?xml version="1.0"?>
<!--This CDATA section contains the layout information of the package.
The section includes information such as (x,y) coordinates, width,
and height.-->
<!--If you manually edit this section and make a mistake, you can
delete it. -->
<!--The package will still be able to load normally but the previous
layout information will be lost and the designer will automatically
re-arrange the elements on the design surface.-->
<Objects
  Version="sql11">
  <!--Each node below will contain properties that do not affect
runtime behavior.-->
  <Package
    design-time-name="Package">
    <LayoutInfo>
      <GraphLayout
        Capacity="4" xmlns="clr-namespace:Microsoft.SqlServer.
IntegrationServices.Designer.Model.
Serialization;assembly=Microsoft.SqlServer.IntegrationServices.Graph"
        xmlns:mssggle="clr-namespace:Microsoft.SqlServer.Graph.LayoutEngine;
assembly=Microsoft.SqlServer.Graph"
        xmlns:x="http://schemas.microsoft.com/winfx/2006/xaml">
        <NodeLayout
          Size="183.735849056604,43.9245283018868"
          Id="Package\Get Stock Quote"
          TopLeft="5.5,5.5" />
        <NodeLayout
          Size="135.773584905661,43.9245283018868"
          Id="Package\Show Stock Price"
          TopLeft="29.4622641509434,96.2547169811321" />
        <EdgeLayout
          Id="Package.PrecedenceConstraints[Constraint 1]"
          TopLeft="97.3490566037736,49.4245283018868">
          <EdgeLayout.Curve>
            <mssggle:Curve
              StartConnector="{x:Null}"
              EndConnector="0,46.8301886792453"
              Start="0,0"
              End="0,39.3301886792453">
              <mssggle:Curve.Segments>
                <mssggle:SegmentCollection
                  Capacity="5">
                  <mssggle:LineSegment
                    End="0,39.3301886792453" />
                </mssggle:SegmentCollection>
              </mssggle:Curve.Segments>
            </mssggle:Curve>
          </EdgeLayout.Curve>
        </EdgeLayout>
      </GraphLayout>
    </LayoutInfo>
  </Package>
</Objects>

```

```

        </mssggle:Curve>
    </EdgeLayout.Curve>
    <EdgeLayout.Labels>
        <EdgeLabelCollection />
    </EdgeLayout.Labels>
</EdgeLayout>
</GraphLayout>
</LayoutInfo>
</Package>
</Objects>]]></DTS:DesignTimeProperties>
</DTS:Executable>

```

3.3 Example of Custom Executable

The following package file contains a custom executable. The package file deviates from the specified XSD because of the presence of the custom executable, as follows.

The **ExecutableType** attribute on the [Executable](#) element is not in the enumeration type, [AnyNonPackageExecutableTypeExecutableTypeEnum](#). The following snippet shows the differing part of the package file.

```

    <DTS:Executable DTS:ExecutableType=
    "CustomFileCopyTask.CustomFileCopy, CustomFileCopyTask, Version=1.0.0.0, Culture=neutral,
    PublicKeyToken=6d9410f0409e8e15"

```

For detailed information about how custom executables affect the defined DTSX structure, see [Custom Executable](#).

The **InnerObject** element in the sample below does not deviate from the XSD, because the element's type allows it to contain any XML. However, the XML content of the **InnerObject** element represents the custom XML that was defined by the custom executable, as follows.

```

    <DestFileName Type="8" Value="%TEMP%\f1.txt"/>
    <SourceFileName Type="8" Value="%TEMP%\SampleCurrencyData.txt"/>

```

The following is the complete package file.

```

<?xml version="1.0"?>
<DTS:Executable xmlns:DTS="www.microsoft.com/SqlServer/Dts"
    DTS:refId="Package"
    DTS:DTSID="{6CFF106A-0132-450D-9FD6-E19D01C7780C}"
    DTS:CreationName="MSDTS.Package.1"
    DTS:ExecutableType="SSIS.Package.3"
    DTS:CreatorName="DOMAIN\username"
    DTS:CreatorComputerName="KEVIRT01"
    DTS:CreationDate="11/25/2007 3:35:28 PM"
    DTS:PackageType="5"
    DTS:VersionMajor="5"
    DTS:VersionMinor="0"
    DTS:VersionBuild="5"
    DTS:VersionGUID="{7D0F00C8-26E7-4BFE-8999-126CC0E52C0C}"

```

```

                DTS:LocaleID="1033"
                DTS:ExecValueType="3"
            >
        <DTS:Property DTS:Name="PackageFormatVersion">2</DTS:Property>
        <DTS:LoggingOptions/>
        <DTS:Executables>
        <DTS:Executable DTS:ExecutableType=
"CustomFileCopyTask.CustomFileCopy, CustomFileCopyTask, Version=
1.0.0.0, Culture=neutral, PublicKeyToken=6d9410f0409e8e15"
                DTS:ThreadHint="0"
                DTS:refId="Package\CustomFileCopyTask"
                DTS:TaskContact="CustomFileCopyTask, Copyright (c) Microsoft"
                DTS:LocaleID="-1"
                DTS:ObjectName="CustomFileCopyTask"
                DTS:DTSID="{EE0A16EB-383A-4A14-91BB-C675FD077064}"
                DTS:Description="CustomFileCopyTask"
                DTS:CreationName="CustomFileCopyTask.CustomFileCopy, CustomFileCopyTask
, Version=1.0.0.0, Culture=neutral, PublicKeyToken=6d9410f0409e8e15"
                DTS:ExecValueType="3"
            >
        <DTS:LoggingOptions/>
        <DTS:ObjectData>
        <InnerObject>
            <DestFileName Type="8" Value="%TEMP%\f1.txt"/>
            <SourceFileName Type="8" Value="%TEMP%\SampleCurrencyData.txt"/>
        </InnerObject>
        </DTS:ObjectData>
    </DTS:Executable>
</DTS:Executables>
<DTS:PackageVariables>
<DTS:PackageVariable>
    <DTS:Property DTS:Name="PackageVariableValue" DTS:DataType="8">
        &lt;Package xmlns:xsd="http://www.w3.org/2001/XMLSchema"
xmlns:xsi="http://www.w3.org/2001/XMLSchema-instance"
xmlns:ddl2="http://schemas.microsoft.com/analysisisservices/2003/engine/2"
xmlns:ddl2_2="http://schemas.microsoft.com/analysisisservices/2003/engine/2/2"
xmlns:dwd="http://schemas.microsoft.com/DataWarehouse/Designer/1.0"&gt;&lt;dwd:DtsControlFlow
Diagram&gt;&lt;dwd:BoundingLeft&gt;1000&lt;/dwd:BoundingLeft&gt;&lt;dwd:BoundingTop&gt;-
500&lt;/dwd:BoundingTop&gt;&lt;dwd:Layout&gt;&lt;dds&gt;
        &lt;diagram fontclsid="{0BE35203-8F91-11CE-9DE3-00AA004BB851}"
mouseiconclsid="{0BE35204-8F91-11CE-9DE3-00AA004BB851}"
defaultlayout="Microsoft.DataWarehouse.Layout.GraphLayout"
defaultlineroute="Microsoft.DataWarehouse.Layout.GraphLayout" version="7" nextobject="5"
scale="100" pagebreakanchorx="0" pagebreakanchory="0" pagebreaksizex="0" pagebreaksizey="0"
scrollleft="0" scrolltop="-1500" gridx="150" gridy="150" marginx="1000" marginy="1000"
zoom="100" x="34131" y="19526" backcolor="15334399" defaultpersistence="2"
PrintPageNumbersMode="3" PrintMarginTop="0" PrintMarginBottom="635" PrintMarginLeft="0"
PrintMarginRight="0" marqueeselectionmode="1" mousepointer="0" snaptogrid="0"
autotypeannotation="1" showscrollbars="0" viewpagebreaks="0"
donotforceconnectorsbehindshapes="1" backpictureclsid="{00000000-0000-0000-0000-
000000000000}"&gt;
            &lt;font&gt;
            &lt;ddsxmlobjectstreamwrapper binary="01010000900180380100065461686f6d61" /&gt;
            &lt;/font&gt;
            &lt;mouseicon&gt;
            &lt;ddsxmlobjectstreamwrapper binary="6c74000000000000" /&gt;
            &lt;/mouseicon&gt;
            &lt;/diagram&gt;
            &lt;layoutmanager&gt;
            &lt;ddsxmlobj /&gt;

```

```

        </layoutmanager>
        <ddscontrol controlprogid="DdsShapes.DdsObjectManagedBridge.1"
        tooltip="CustomFileCopyTask" left="1000" top="344" logicalid="2" controlid="1" masterid="0"
        hint1="0" hint2="0" width="3598" height="1164" noresize="0" nomove="0"
        nodefaultattachpoints="0" autodrag="1" usedefaultiddshape="1" selectable="1"
        showselectionhandles="1" allownudging="1" isannotation="0" dontautolayout="0"
        groupcollapsed="0" tabstop="1" visible="1" snaptogrid="0">
            <control>
                <ddsmobjectstreaminitwrapper binary="000800000e0e00008c040000" />
            </control>
            <layoutobject>
                <ddsmobj>
                    <property name="LogicalObject" value="{EE0A16EB-383A-4A14-91BB-C675FD077064}"
                    vartype="8" />
                    <property name="ShowConnectorSource" value="0" vartype="2" />
                </ddsmobj>
            </layoutobject>
            <shape groupshapeid="0" groupnode="0" />
        </ddscontrol>
        </dds>
    </dwd:Layout>
    </dwd:PersistedViewPortTop>
    1500</dwd:PersistedViewPortTop>
    </dwd:DtsControlFlowDiagram>
    </Package>
</DTS:Property>
<DTS:Property DTS:Name="Namespace">dts-designer-1.0</DTS:Property>
<DTS:Property DTS:Name="
    "ObjectName">{6CFF106A-0132-450D-9FD6-E19D01C7780C}</DTS:Property>
<DTS:Property DTS:Name="DTSID">
    {5A29FF6D-763B-40AF-A400-C83A8735638E}
</DTS:Property>
<DTS:Property DTS:Name="Description"></DTS:Property>
<DTS:Property DTS:Name="CreationName"></DTS:Property>
</DTS:PackageVariable>
</DTS:PackageVariables>
</DTS:Executable>

```

3.4 Example of Custom Component

The following **package file** contains a custom component. The package file deviates from the specified XSD because of the presence the custom component as described here and as shown in the full package file below.

The **ExecutableType** attribute value is a custom value that is specified by the custom component, as follows.

```

"CustomFileCopyTask.CustomFileCopy, CustomFileCopyTask, Version=1.0.0.0, Culture=neutral,
PublicKeyToken=6d9410f0409e8e15"

```

The **componentClassID** attribute value is a custom value that is specified by the custom component and is not present in the specified XSD.

```

<component id="1" name="CalendarTransform"
    componentClassID="{BF01D463-7089-41EE-8F05-0A6DC17CE633}"
    description="Generates Roman, financial, reporting, manufacturing and IOS8601
    calendar data."
    localeId="-1" usesDispositions="false"
    validateExternalMetadata="True" version="0"
    pipelineVersion="0" contactInfo="">

```

Each of the following properties is not a specified property in the XSD and is a custom value that is specified defined by the custom component.

```

        <property id="5" name="First day of week"
            dataType="System.String" state="default"
            isArray="false" description="Start day of logical week"
            typeConverter="Microsoft.Samples.SqlServer.Dts.DataFlow.FirstDayOfWeekConverter, CalendarTransform, Version=1.0.0.0, Culture=neutral, PublicKeyToken=e9fac57941009407"
            UITypeEditor="" containsID="false"
            expressionType="None">Tuesday</property>

<property id="6" name="Fiscal definition"
    dataType="System.String" state="default"
    isArray="false" description=
    "Parameter list defining fiscal calendar"
    typeConverter="" UITypeEditor="" containsID="false"
    expressionType="None">StartDay=1,StartMonth=1,YearDelta=0
</property>

<property id="7" name="Manufacturing definition"
    dataType="System.String" state="default" isArray="false"
description="Parameter list defining manufacturing calendar"
    typeConverter="" UITypeEditor="" containsID="false"
    expressionType="None">StartMonth=1,StartWeek=1,Quarter=1
</property>
    <property id="8" name="Reporting definition" dataType=
    "System.String" state="default" isArray="false"
    description="Parameter list defining reporting calendar"
    typeConverter="" UITypeEditor="" containsID="false"
    expressionType="None">StartMonth=1,StartWeek=1,Pattern=445
</property>
        <property id="167" name="Attribute Type" dataType=
            "System.String" state="default" isArray=
            "false" description="Time period attribute type"
            typeConverter=
                "Microsoft.Samples.SqlServer.Dts.DataFlow.TimeAttributeTypeConverter,
                CalendarTransform, Version=1.0.0.0, Culture=neutral, PublicKeyToken=e9fac57941009407"
            UITypeEditor="" containsID="false"
            expressionType="None">Days</property>
        <property id="168" name="Attribute Part" dataType=
            "System.String" state="default" isArray=
            "false" description="Time period attribute part"
            typeConverter=
                "Microsoft.Samples.SqlServer.Dts.DataFlow.TimeAttributePartConverter,
                CalendarTransform, Version=1.0.0.0, Culture=neutral, PublicKeyToken=e9fac57941009407"
            UITypeEditor="" containsID="false"
            expressionType="None">Key</property>
        <property id="169" name="Format" dataType=
            "System.String" state="default"
            isArray="false" description=
            "Optional format string (output coerced to string)"
            typeConverter="" UITypeEditor=""
            containsID="false" expressionType="None">
</property>

```

For detailed information about how custom components affect the defined DTSX structure, see [Custom Component](#).

```
<?xml version="1.0"?>
<DTS:Executable xmlns:DTS="www.microsoft.com/SqlServer/Dts"
  DTS:ExecutableType="SSIS.Package.2">
  <DTS:Property DTS:Name="PackageFormatVersion">2</DTS:Property>
  <DTS:Property DTS:Name="VersionComments"></DTS:Property>
  <DTS:Property DTS:Name="CreatorName">DOMAIN\username</DTS:Property>
  <DTS:Property DTS:Name="CreatorComputerName">KEVIRT01</DTS:Property>
  <DTS:Property DTS:Name="CreationDate" DTS:DataType="7">
    11/20/2007 11:29:04 AM</DTS:Property>
  <DTS:Property DTS:Name="PackageType">5</DTS:Property>
  <DTS:Property DTS:Name="ProtectionLevel">1</DTS:Property>
  <DTS:Property DTS:Name="MaxConcurrentExecutables">-1</DTS:Property>
  <DTS:Property DTS:Name="PackagePriorityClass">0</DTS:Property>
  <DTS:Property DTS:Name="VersionMajor">1</DTS:Property>
  <DTS:Property DTS:Name="VersionMinor">0</DTS:Property>
  <DTS:Property DTS:Name="VersionBuild">5</DTS:Property>
  <DTS:Property DTS:Name="VersionGUID">
    {18F30840-EE8E-4119-B16D-85D3DC24B6DC}</DTS:Property>
  <DTS:Property DTS:Name="EnableConfig">0</DTS:Property>
  <DTS:Property DTS:Name="CheckpointFileName"></DTS:Property>
  <DTS:Property DTS:Name="SaveCheckpoints">0</DTS:Property>
  <DTS:Property DTS:Name="CheckpointUsage">0</DTS:Property>
  <DTS:Property DTS:Name="SuppressConfigurationWarnings">0</DTS:Property>
  <DTS:Property DTS:Name="ForceExecValue">0</DTS:Property>
  <DTS:Property DTS:Name="ExecValue" DTS:DataType="3">0</DTS:Property>
  <DTS:Property DTS:Name="ForceExecutionResult">-1</DTS:Property>
  <DTS:Property DTS:Name="Disabled">0</DTS:Property>
  <DTS:Property DTS:Name="FailPackageOnFailure">0</DTS:Property>
  <DTS:Property DTS:Name="FailParentOnFailure">0</DTS:Property>
  <DTS:Property DTS:Name="MaxErrorCount">1</DTS:Property>
  <DTS:Property DTS:Name="ISOLevel">1048576</DTS:Property>
  <DTS:Property DTS:Name="LocaleID">1033</DTS:Property>
  <DTS:Property DTS:Name="TransactionOption">1</DTS:Property>
  <DTS:Property DTS:Name="DelayValidation">0</DTS:Property>
  <DTS:Property DTS:Name="ObjectName">Package</DTS:Property>
  <DTS:Property DTS:Name="DTSID">{61EDFABA-B54F-4EFE-9FF2-DABDD94B9D51}
</DTS:Property>
  <DTS:Property DTS:Name="Description"></DTS:Property>
  <DTS:Property DTS:Name="CreationName">MSDTS.Package.1</DTS:Property>
  <DTS:Property DTS:Name="DisableEventHandlers">0</DTS:Property>
  <DTS:ConnectionManager>
    <DTS:Property DTS:Name="DelayValidation">0</DTS:Property>
    <DTS:Property DTS:Name="ObjectName">Flat File Connection Manager
</DTS:Property>
    <DTS:Property DTS:Name="DTSID">{4F717107-732B-4C1B-AAF5-A5A31B6FECE8}
</DTS:Property>
    <DTS:Property DTS:Name="Description"></DTS:Property>
    <DTS:Property DTS:Name="CreationName">FLATFILE</DTS:Property>
    <DTS:ObjectData>
      <DTS:ConnectionManager>
        <DTS:Property DTS:Name="FileUsageType">0</DTS:Property>
        <DTS:Property DTS:Name="Format">FixedWidth</DTS:Property>
        <DTS:Property DTS:Name="LocaleID">1033</DTS:Property>
        <DTS:Property DTS:Name="Unicode">0</DTS:Property>
        <DTS:Property DTS:Name="HeaderRowsToSkip">0</DTS:Property>
      </DTS:ConnectionManager>
    </DTS:ObjectData>
  </DTS:Executable>
</DTS:Package>
```

```

<DTS:Property DTS:Name="HeaderRowDelimiter"
    xml:space="preserve">_x000D_x000A_</DTS:Property>
<DTS:Property DTS:Name="ColumnNamesInFirstDataRow">0
</DTS:Property>
<DTS:Property DTS:Name="RowDelimiter" xml:space="preserve">
</DTS:Property>
<DTS:Property DTS:Name="DataRowsToSkip">0</DTS:Property>
<DTS:Property DTS:Name="TextQualifier">&lt;none&gt;</DTS:Property>
<DTS:Property DTS:Name="CodePage">1252</DTS:Property>
<DTS:Property DTS:Name="ConnectionString">
C:\Documents and Settings\Administrator\Local Settings\Temp\fl.txt
</DTS:Property>
<DTS:FlatFileColumn>
  <DTS:Property DTS:Name="ColumnType">FixedWidth</DTS:Property>
  <DTS:Property DTS:Name="ColumnDelimiter" xml:space="preserve">
  </DTS:Property>
  <DTS:Property DTS:Name="ColumnWidth">24</DTS:Property>
  <DTS:Property DTS:Name="MaximumWidth">0</DTS:Property>
  <DTS:Property DTS:Name="DataType">4</DTS:Property>
  <DTS:Property DTS:Name="DataPrecision">0</DTS:Property>
  <DTS:Property DTS:Name="DataScale">0</DTS:Property>
  <DTS:Property DTS:Name="TextQualified">-1</DTS:Property>
  <DTS:Property DTS:Name="ObjectName">Column 0</DTS:Property>
  <DTS:Property DTS:Name="DTSID">
    {5EC860DF-B362-4219-A057-FFB39B58905E}</DTS:Property>
  <DTS:Property DTS:Name="Description"></DTS:Property>
  <DTS:Property DTS:Name="CreationName"></DTS:Property>
</DTS:FlatFileColumn>
<DTS:FlatFileColumn>
  <DTS:Property DTS:Name="ColumnType">FixedWidth</DTS:Property>
  <DTS:Property DTS:Name="ColumnDelimiter" xml:space="preserve">
  </DTS:Property>
  <DTS:Property DTS:Name="ColumnWidth">3</DTS:Property>
  <DTS:Property DTS:Name="MaximumWidth">3</DTS:Property>
  <DTS:Property DTS:Name="DataType">129</DTS:Property>
  <DTS:Property DTS:Name="DataPrecision">0</DTS:Property>
  <DTS:Property DTS:Name="DataScale">0</DTS:Property>
  <DTS:Property DTS:Name="TextQualified">-1</DTS:Property>
  <DTS:Property DTS:Name="ObjectName">Column 1</DTS:Property>
  <DTS:Property DTS:Name="DTSID">
    {7657CF3B-099A-4DE3-9790-257BC29911D8}</DTS:Property>
  <DTS:Property DTS:Name="Description"></DTS:Property>
  <DTS:Property DTS:Name="CreationName"></DTS:Property>
</DTS:FlatFileColumn>
<DTS:FlatFileColumn>
  <DTS:Property DTS:Name="ColumnType">FixedWidth</DTS:Property>
  <DTS:Property DTS:Name="ColumnDelimiter" xml:space="preserve">
  </DTS:Property>
  <DTS:Property DTS:Name="ColumnWidth">24</DTS:Property>
  <DTS:Property DTS:Name="MaximumWidth">0</DTS:Property>
  <DTS:Property DTS:Name="DataType">4</DTS:Property>
  <DTS:Property DTS:Name="DataPrecision">0</DTS:Property>
  <DTS:Property DTS:Name="DataScale">0</DTS:Property>
  <DTS:Property DTS:Name="TextQualified">-1</DTS:Property>
  <DTS:Property DTS:Name="ObjectName">Column 3</DTS:Property>
  <DTS:Property DTS:Name="DTSID">
    {384A703C-66ED-4ACB-9A65-AE1218D1B72F}</DTS:Property>
  <DTS:Property DTS:Name="Description"></DTS:Property>
  <DTS:Property DTS:Name="CreationName"></DTS:Property>

```

```

</DTS:FlatFileColumn>
<DTS:FlatFileColumn>
  <DTS:Property DTS:Name="ColumnType">FixedWidth</DTS:Property>
  <DTS:Property DTS:Name="ColumnDelimiter" xml:space="preserve">
</DTS:Property>
  <DTS:Property DTS:Name="ColumnWidth">23</DTS:Property>
  <DTS:Property DTS:Name="MaximumWidth">0</DTS:Property>
  <DTS:Property DTS:Name="DataType">7</DTS:Property>
  <DTS:Property DTS:Name="DataPrecision">0</DTS:Property>
  <DTS:Property DTS:Name="DataScale">0</DTS:Property>
  <DTS:Property DTS:Name="TextQualified">-1</DTS:Property>
  <DTS:Property DTS:Name="ObjectName">DateColumn</DTS:Property>
  <DTS:Property DTS:Name="DTSID">
{E58B1BF2-BBC1-4C4E-84CE-EDB786620D1A}</DTS:Property>
  <DTS:Property DTS:Name="Description"></DTS:Property>
  <DTS:Property DTS:Name="CreationName"></DTS:Property>
</DTS:FlatFileColumn>
<DTS:FlatFileColumn>
  <DTS:Property DTS:Name="ColumnType">FixedWidth</DTS:Property>
  <DTS:Property DTS:Name="ColumnDelimiter" xml:space="preserve">
</DTS:Property>
  <DTS:Property DTS:Name="ColumnWidth">30</DTS:Property>
  <DTS:Property DTS:Name="MaximumWidth">0</DTS:Property>
  <DTS:Property DTS:Name="DataType">135</DTS:Property>
  <DTS:Property DTS:Name="DataPrecision">0</DTS:Property>
  <DTS:Property DTS:Name="DataScale">0</DTS:Property>
  <DTS:Property DTS:Name="TextQualified">-1</DTS:Property>
  <DTS:Property DTS:Name="ObjectName">Column</DTS:Property>
  <DTS:Property DTS:Name="DTSID">
{42D205F3-5045-4220-8039-2D901E25061A}</DTS:Property>
  <DTS:Property DTS:Name="Description"></DTS:Property>
  <DTS:Property DTS:Name="CreationName"></DTS:Property>
</DTS:FlatFileColumn>
</DTS:ConnectionManager>
</DTS:ObjectData>
</DTS:ConnectionManager>
<DTS:ConnectionManager>
  <DTS:Property DTS:Name="DelayValidation">0</DTS:Property>
  <DTS:Property DTS:Name="ObjectName">Sample Flat connection
</DTS:Property>
  <DTS:Property DTS:Name="DTSID">{00F5DC11-75D6-49FC-BE02-C4984643F39A}
</DTS:Property>
  <DTS:Property DTS:Name="Description"></DTS:Property>
  <DTS:Property DTS:Name="CreationName">FLATFILE</DTS:Property>
<DTS:ObjectData>
  <DTS:ConnectionManager>
    <DTS:Property DTS:Name="FileUsageType">0</DTS:Property>
    <DTS:Property DTS:Name="Format">Delimited</DTS:Property>
    <DTS:Property DTS:Name="LocaleID">1033</DTS:Property>
    <DTS:Property DTS:Name="Unicode">0</DTS:Property>
    <DTS:Property DTS:Name="HeaderRowsToSkip">0</DTS:Property>
    <DTS:Property DTS:Name="HeaderRowDelimiter"
      xml:space="preserve">_x000D_x000A_</DTS:Property>
    <DTS:Property DTS:Name="ColumnNamesInFirstDataRow">0</DTS:Property>
    <DTS:Property DTS:Name="RowDelimiter" xml:space="preserve">
</DTS:Property>
    <DTS:Property DTS:Name="DataRowsToSkip">0</DTS:Property>
    <DTS:Property DTS:Name="TextQualifier">&lt;none&gt;</DTS:Property>
    <DTS:Property DTS:Name="CodePage">1252</DTS:Property>

```



```

    <DTS:Property DTS:Name="ConnectionString">
C:\Documents and Settings\Administrator\Local Settings\Temp\t1.txt
    </DTS:Property>
    <DTS:FlatFileColumn>
      <DTS:Property DTS:Name="ColumnType">Delimited</DTS:Property>
      <DTS:Property DTS:Name="ColumnDelimiter"
        xml:space="preserve">_x0009_</DTS:Property>
      <DTS:Property DTS:Name="ColumnWidth">0</DTS:Property>
      <DTS:Property DTS:Name="MaximumWidth">0</DTS:Property>
      <DTS:Property DTS:Name="DataType">4</DTS:Property>
      <DTS:Property DTS:Name="DataPrecision">0</DTS:Property>
      <DTS:Property DTS:Name="DataScale">0</DTS:Property>
      <DTS:Property DTS:Name="TextQualified">-1</DTS:Property>
      <DTS:Property DTS:Name="ObjectName">Column 0</DTS:Property>
      <DTS:Property DTS:Name="DTSID">
{B595CAF1-EFA8-4F91-9813-E46E9BA0B23C}</DTS:Property>
      <DTS:Property DTS:Name="Description"></DTS:Property>
      <DTS:Property DTS:Name="CreationName"></DTS:Property>
    </DTS:FlatFileColumn>
    <DTS:FlatFileColumn>
      <DTS:Property DTS:Name="ColumnType">Delimited</DTS:Property>
      <DTS:Property DTS:Name="ColumnDelimiter"
        xml:space="preserve">_x0009_</DTS:Property>
      <DTS:Property DTS:Name="ColumnWidth">0</DTS:Property>
      <DTS:Property DTS:Name="MaximumWidth">3</DTS:Property>
      <DTS:Property DTS:Name="DataType">129</DTS:Property>
      <DTS:Property DTS:Name="DataPrecision">0</DTS:Property>
      <DTS:Property DTS:Name="DataScale">0</DTS:Property>
      <DTS:Property DTS:Name="TextQualified">-1</DTS:Property>
      <DTS:Property DTS:Name="ObjectName">Column 1</DTS:Property>
      <DTS:Property DTS:Name="DTSID">
{68CD7506-DD5C-4D29-BB9E-E35F3AFCE310}</DTS:Property>
      <DTS:Property DTS:Name="Description"></DTS:Property>
      <DTS:Property DTS:Name="CreationName"></DTS:Property>
    </DTS:FlatFileColumn>
    <DTS:FlatFileColumn>
      <DTS:Property DTS:Name="ColumnType">Delimited</DTS:Property>
      <DTS:Property DTS:Name="ColumnDelimiter"
        xml:space="preserve">_x0009_</DTS:Property>
      <DTS:Property DTS:Name="ColumnWidth">0</DTS:Property>
      <DTS:Property DTS:Name="MaximumWidth">0</DTS:Property>
      <DTS:Property DTS:Name="DataType">7</DTS:Property>
      <DTS:Property DTS:Name="DataPrecision">0</DTS:Property>
      <DTS:Property DTS:Name="DataScale">0</DTS:Property>
      <DTS:Property DTS:Name="TextQualified">-1</DTS:Property>
      <DTS:Property DTS:Name="ObjectName">DateColumn</DTS:Property>
      <DTS:Property DTS:Name="DTSID">
{95B6A9B8-2732-42A5-8091-7751E2CBE35A}</DTS:Property>
      <DTS:Property DTS:Name="Description"></DTS:Property>
      <DTS:Property DTS:Name="CreationName"></DTS:Property>
    </DTS:FlatFileColumn>
    <DTS:FlatFileColumn>
      <DTS:Property DTS:Name="ColumnType">Delimited</DTS:Property>
      <DTS:Property DTS:Name="ColumnDelimiter"
        xml:space="preserve">_x000D_x000A_</DTS:Property>
      <DTS:Property DTS:Name="ColumnWidth">0</DTS:Property>
      <DTS:Property DTS:Name="MaximumWidth">0</DTS:Property>
      <DTS:Property DTS:Name="DataType">4</DTS:Property>
      <DTS:Property DTS:Name="DataPrecision">0</DTS:Property>

```

```

        <DTS:Property DTS:Name="DataScale">0</DTS:Property>
        <DTS:Property DTS:Name="TextQualified">-1</DTS:Property>
        <DTS:Property DTS:Name="ObjectName">Column 3</DTS:Property>
        <DTS:Property DTS:Name="DTSID">
{A3C6406D-E017-44A7-A217-8171E5E04326}</DTS:Property>
        <DTS:Property DTS:Name="Description"></DTS:Property>
        <DTS:Property DTS:Name="CreationName"></DTS:Property>
    </DTS:FlatFileColumn>
</DTS:ConnectionManager>
</DTS:ObjectData>
</DTS:ConnectionManager>
<DTS:LoggingOptions>
    <DTS:Property DTS:Name="LoggingMode">0</DTS:Property>
    <DTS:Property DTS:Name="FilterKind">1</DTS:Property>
    <DTS:Property DTS:Name="EventFilter" DTS:DataType="8"></DTS:Property>
</DTS:LoggingOptions>
<DTS:Executable
    DTS:ExecutableType=
"CustomFileCopyTask.CustomFileCopy, CustomFileCopyTask, Version=1.0.0.0, Culture=neutral,
PublicKeyToken=6d9410f0409e8e15"
    DTS:ThreadHint="0">
<DTS:Property DTS:Name="ExecutionLocation">0</DTS:Property>
<DTS:Property DTS:Name="ExecutionAddress"></DTS:Property>
<DTS:Property DTS:Name="TaskContact">
    CustomFileCopyTask, Copyright (c) Microsoft</DTS:Property>
<DTS:Property DTS:Name="ForceExecValue">0</DTS:Property>
<DTS:Property DTS:Name="ExecValue" DTS:DataType="3">0</DTS:Property>
<DTS:Property DTS:Name="ForceExecutionResult">-1</DTS:Property>
<DTS:Property DTS:Name="Disabled">0</DTS:Property>
<DTS:Property DTS:Name="FailPackageOnFailure">0</DTS:Property>
<DTS:Property DTS:Name="FailParentOnFailure">0</DTS:Property>
<DTS:Property DTS:Name="MaxErrorCount">1</DTS:Property>
<DTS:Property DTS:Name="ISOLevel">1048576</DTS:Property>
<DTS:Property DTS:Name="LocaleID">-1</DTS:Property>
<DTS:Property DTS:Name="TransactionOption">1</DTS:Property>
<DTS:Property DTS:Name="DelayValidation">0</DTS:Property>
<DTS:Property DTS:Name="ObjectName">CustomFileCopyTask</DTS:Property>
<DTS:Property DTS:Name="DTSID">{E4168410-1CEC-4CC2-975D-9349F44ABEDB}
</DTS:Property>
<DTS:Property DTS:Name="Description">CustomFileCopyTask</DTS:Property>
<DTS:Property DTS:Name="CreationName">
CustomFileCopyTask.CustomFileCopy, CustomFileCopyTask, Version=1.0.0.0, Culture=neutral,
PublicKeyToken=6d9410f0409e8e15
    </DTS:Property>
<DTS:Property DTS:Name="DisableEventHandlers">0</DTS:Property>
<DTS:LoggingOptions>
    <DTS:Property DTS:Name="LoggingMode">0</DTS:Property>
    <DTS:Property DTS:Name="FilterKind">1</DTS:Property>
    <DTS:Property DTS:Name="EventFilter" DTS:DataType="8"></DTS:Property>
</DTS:LoggingOptions>
<DTS:ObjectData>
    <InnerObject>
        <DestFileName Type="8" Value="%TEMP%\t1.txt"/>
        <SourceFileName Type="8" Value="%TEMP%\SampleCurrencyData.txt"/>
    </InnerObject>
</DTS:ObjectData>
</DTS:Executable>
<DTS:Executable DTS:ExecutableType="SSIS.Pipeline.2">
    <DTS:Property DTS:Name="ExecutionLocation">0</DTS:Property>

```

```

    <DTS:Property DTS:Name="ExecutionAddress"></DTS:Property>
    <DTS:Property DTS:Name="TaskContact">
Performs high-performance data extraction, transformation and loading;Microsoft Corporation;
Microsoft SQL Server v9; (C) 2004 Microsoft Corporation; All Rights
Reserved;http://www.microsoft.com/sql/support/default.asp;1
    </DTS:Property>
    <DTS:Property DTS:Name="ForceExecValue">0</DTS:Property>
    <DTS:Property DTS:Name="ExecValue" DTS:DataType="3">0</DTS:Property>
    <DTS:Property DTS:Name="ForceExecutionResult">-1</DTS:Property>
    <DTS:Property DTS:Name="Disabled">0</DTS:Property>
    <DTS:Property DTS:Name="FailPackageOnFailure">0</DTS:Property>
    <DTS:Property DTS:Name="FailParentOnFailure">0</DTS:Property>
    <DTS:Property DTS:Name="MaxErrorCount">1</DTS:Property>
    <DTS:Property DTS:Name="ISOLevel">1048576</DTS:Property>
    <DTS:Property DTS:Name="LocaleID">-1</DTS:Property>
    <DTS:Property DTS:Name="TransactionOption">1</DTS:Property>
    <DTS:Property DTS:Name="DelayValidation">0</DTS:Property>
    <DTS:Property DTS:Name="ObjectName">Data Flow Task</DTS:Property>
    <DTS:Property DTS:Name="DTSID">{23B174F1-23C2-49F9-8512-03D5A2677E67}
</DTS:Property>
    <DTS:Property DTS:Name="Description">Data Flow Task</DTS:Property>
    <DTS:Property DTS:Name="CreationName">DTS.Pipeline.1</DTS:Property>
    <DTS:Property DTS:Name="DisableEventHandlers">0</DTS:Property>
    <DTS:LoggingOptions>
    <DTS:Property DTS:Name="LoggingMode">0</DTS:Property>
    <DTS:Property DTS:Name="FilterKind">1</DTS:Property>
    <DTS:Property DTS:Name="EventFilter" DTS:DataType="8"></DTS:Property>
</DTS:LoggingOptions>
    <DTS:ObjectData>
    <pipeline id="0" name="pipelineXml" description="pipelineXml"
    defaultBufferMaxRows="10000" engineThreads="5" defaultBufferSize=
    "10485760" BLOBTempStoragePath="" bufferTempStoragePath=""
    runInOptimizedMode="true">
    <components>
    <component id="20" name="Flat File Source" componentClassID=
    "{5ACD952A-F16A-41D8-A681-713640837664}" description=
    "Flat File Source" localeId="1033" usesDispositions="true"
    validateExternalMetadata="True" version="1" pipelineVersion="0"
    contactInfo=
    "Flat File Source;Microsoft Corporation;Microsoft SqlServer v9; (C) 2005 Microsoft
    Corporation; All Rights Reserved; http://www.microsoft.com/sql/support;1">
    <properties>
    <property id="26" name="RetainNulls" dataType=
    "System.Boolean" state="default" isArray="false"
    description="Specifies whether zero-length columns
    are treated as null." typeConverter="" UITypeEditor=""
    containsID="false" expressionType="None">false</property>
    <property id="27" name="FileNameColumnName" dataType="System.String"
    state="default" isArray="false" description="Specifies the name of an output column
    containing the file name. If no name is specified, no output column containing the file name
    will be generated." typeConverter="" UITypeEditor="" containsID="false"
    expressionType="None"></property>
    </properties>
    <connections>
    <connection id="25" name="FlatFileConnection" description=""
    connectionManagerID="{00F5DC11-75D6-49FC-BE02-C4984643F39A}"/>
    </connections>
    <outputs>
    <output id="21" name="Flat File Source Output" description

```

```

="\" exclusionGroup="0" synchronousInputId="0"
deleteOutputOnPathDetached="false" hasSideEffects="false"
dangling="false" isErrorOut="false" isSorted="false"
errorOrTruncationOperation="" errorRowDisposition="NotUsed"
truncationRowDisposition="NotUsed">
  <outputColumns>
    <outputColumn id="45" name="Column 0" description=""
      lineageId="45" precision="0" scale="0" length="0"
      dataType="r4" codePage="0" sortKeyPosition="0"
      comparisonFlags="0" specialFlags="0"
      errorOrTruncationOperation="Conversion"
      errorRowDisposition="FailComponent"
      truncationRowDisposition="FailComponent"
      externalMetadataColumnId="44">
      <properties>
        <property id="46" name="FastParse" dataType=
          "System.Boolean" state="default" isArray="false"
description="Indicates whether the column uses the faster, locale-neutral parsing routines."
          typeConverter="" UITypeEditor="" containsID="false"
          expressionType="None">false</property>
        <property id="47" name="UseBinaryFormat" dataType=
          "System.Boolean" state="default" isArray="false"
description="Indicates whether the data is in binary format."
          typeConverter="" UITypeEditor="" containsID="false"
          expressionType="None">false</property>
      </properties>
    </outputColumn>
    <outputColumn id="49" name="Column 1" description=""
      lineageId="49" precision="0" scale="0" length="3"
      dataType="str" codePage="1252" sortKeyPosition="0"
      comparisonFlags="0" specialFlags="0"
      errorOrTruncationOperation="Conversion"
      errorRowDisposition="FailComponent"
      truncationRowDisposition="FailComponent"
      externalMetadataColumnId="48">
      <properties>
        <property id="50" name="FastParse" dataType=
          "System.Boolean" state="default" isArray="false"
description="Indicates whether the column uses the faster, locale-neutral parsing routines."
          typeConverter="" UITypeEditor="" containsID="false"
          expressionType="None">false</property>
        <property id="51" name="UseBinaryFormat" dataType=
          "System.Boolean" state="default" isArray="false"
description="Indicates whether the data is in binary format."
          typeConverter="" UITypeEditor="" containsID="false"
          expressionType="None">false</property>
      </properties>
    </outputColumn>
    <outputColumn id="57" name="Column 3" description=""
      lineageId="57" precision="0" scale="0" length="0"
      dataType="r4" codePage="0" sortKeyPosition="0"
      comparisonFlags="0" specialFlags="0"
      errorOrTruncationOperation="Conversion"
      errorRowDisposition="FailComponent"
      truncationRowDisposition="FailComponent"
      externalMetadataColumnId="56">
      <properties>
        <property id="58" name="FastParse" dataType=
          "System.Boolean" state="default" isArray="false"

```

```

description="Indicates whether the column uses the faster, locale-neutral parsing routines."
  typeConverter="" UITypeEditor="" containsID="false"
  expressionType="None">false</property>
  <property id="59" name="UseBinaryFormat"
    dataType="System.Boolean" state="default" isArray=
"false" description="Indicates whether the data is in binary format."
    typeConverter="" UITypeEditor="" containsID="false"
    expressionType="None">false</property>
  </properties>
</outputColumn>
<outputColumn id="129" name="DateColumn" description=""
  lineageId="129" precision="0" scale="0" length="0"
  dataType="date" codePage="0" sortKeyPosition="0"
  comparisonFlags="0" specialFlags="0"
  errorOrTruncationOperation="Conversion"
  errorRowDisposition="FailComponent"
  truncationRowDisposition="FailComponent"
  externalMetadataColumnId="128">
  <properties>
    <property id="130" name="FastParse" dataType=
"System.Boolean" state="default" isArray="false"
description="Indicates whether the column uses the faster, locale-neutral parsing routines."
    typeConverter="" UITypeEditor="" containsID="false"
    expressionType="None">false</property>
    <property id="131" name="UseBinaryFormat" dataType=
"System.Boolean" state="default" isArray="false"
description="Indicates whether the data is in binary format."
    typeConverter="" UITypeEditor="" containsID="false"
    expressionType="None">false</property>
  </properties>
</outputColumn>
</outputColumns>
<externalMetadataColumns isUsed="True">
  <externalMetadataColumn id="44" name="Column 0"
    description="" precision="0" scale="0" length="0"
    dataType="r4" codePage="0"/>
  <externalMetadataColumn id="48" name="Column 1"
    description="" precision="0" scale="0" length="3"
    dataType="str" codePage="1252"/>
  <externalMetadataColumn id="56" name="Column 3"
    description="" precision="0" scale="0" length="0"
    dataType="r4" codePage="0"/>
  <externalMetadataColumn id="128" name="DateColumn"
    description="" precision="0" scale="0" length="0"
    dataType="date" codePage="0"/>
</externalMetadataColumns>
</output>
<output id="22" name="Flat File Source Error Output"
  description="" exclusionGroup="0" synchronousInputId="0"
  deleteOutputOnPathDetached="false" hasSideEffects="false"
  dangling="false" isErrorOut="true" isSorted="false"
  errorOrTruncationOperation="" errorRowDisposition="NotUsed"
  truncationRowDisposition="NotUsed">
<outputColumns>
  <outputColumn id="60" name=
  "Flat File Source Error Output Column"
  description="Flat File Source Error Output Column"
  lineageId="60" precision="0" scale="0" length="0"
  dataType="text" codePage="1252" sortKeyPosition="0"

```

```

        comparisonFlags="0" specialFlags="0"
        errorOrTruncationOperation="" errorRowDisposition=
        "NotUsed" truncationRowDisposition="NotUsed"
        externalMetadataColumnId="0"/>
<outputColumn id="23" name="ErrorCode" description=""
    lineageId="23" precision="0" scale="0" length="0"
    dataType="i4" codePage="0" sortKeyPosition="0"
    comparisonFlags="0" specialFlags="1"
    errorOrTruncationOperation=""
    errorRowDisposition="NotUsed" truncationRowDisposition=
    "NotUsed" externalMetadataColumnId="0"/>
<outputColumn id="24" name="ErrorColumn" description=""
    lineageId="24" precision="0" scale="0" length="0"
    dataType="i4" codePage="0" sortKeyPosition="0"
    comparisonFlags="0" specialFlags="2"
    errorOrTruncationOperation="" errorRowDisposition=
    "NotUsed" truncationRowDisposition="NotUsed"
    externalMetadataColumnId="0"/>
</outputColumns>
<externalMetadataColumns isUsed="False"/>
</output>
</outputs>
</component>
<component id="1" name="CalendarTransform"
    componentClassID="{BF01D463-7089-41EE-8F05-0A6DC17CE633}"
description="Generates Roman, financial, reporting, manufacturing and IOS8601 calendar data."
    localeId="-1" usesDispositions="false"
    validateExternalMetadata="True" version="0"
    pipelineVersion="0" contactInfo="">
    <properties>
        <property id="5" name="First day of week"
            dataType="System.String" state="default"
            isArray="false" description="Start day of logical week"
            typeConverter="Microsoft.Samples.SqlServer.Dts.DataFlow.FirstDayOfWeekConverter,
            CalendarTransform, Version=1.0.0.0, Culture=neutral, PublicKeyToken=e9fac57941009407"
            UITypeEditor="" containsID="false"
            expressionType="None">Tuesday</property>
        <property id="6" name="Fiscal definition"
            dataType="System.String" state="default"
            isArray="false" description=
            "Parameter list defining fiscal calendar"
            typeConverter="" UITypeEditor="" containsID="false"
            expressionType="None">StartDay=1,StartMonth=1,YearDelta=0
        </property>
        <property id="7" name="Manufacturing definition"
            dataType="System.String" state="default" isArray="false"
            description="Parameter list defining manufacturing calendar"
            typeConverter="" UITypeEditor="" containsID="false"
            expressionType="None">StartMonth=1,StartWeek=1,Quarter=1
        </property>
        <property id="8" name="Reporting definition" dataType=
            "System.String" state="default" isArray="false"
            description="Parameter list defining reporting calendar"
            typeConverter="" UITypeEditor="" containsID="false"
            expressionType="None">StartMonth=1,StartWeek=1,Pattern=445
        </property>
        <property id="11" name="UserComponentTypeName"
            dataType="System.String" state="default" isArray="false"
            description="" typeConverter="" UITypeEditor=""

```

```

        containsID="false" expressionType="None">
Microsoft.Samples.SqlServer.Dts.DataFlow.CalendarTransform, CalendarTransform,
Version=1.0.0.0, Culture=neutral, PublicKeyToken=e9fac57941009407
</property>
</properties>
<inputs>
  <input id="9" name="CalendarInput" description=
    "Synchronous input columns for component"
    hasSideEffects="false" dangling="false"
    errorOrTruncationOperation="" errorRowDisposition=
    "NotUsed" truncationRowDisposition="NotUsed">
    <inputColumns>
      <inputColumn id="165" name="DateColumn" description=""
        lineageId="129" usageType="readWrite"
        errorOrTruncationOperation=""
        errorRowDisposition="NotUsed"
        truncationRowDisposition="NotUsed"
        externalMetadataColumnId="0"/>
    </inputColumns>
    <externalMetadataColumns isUsed="False"/>
  </input>
</inputs>
<outputs>
  <output id="10" name="CalendarOutput"
description="Synchronous output columns for component"
  exclusionGroup="0" synchronousInputId="9"
  deleteOutputOnPathDetached="false" hasSideEffects=
  "false" dangling="false" isErrorOut="false"
  isSorted="false" errorOrTruncationOperation=""
  errorRowDisposition="NotUsed"
  truncationRowDisposition="NotUsed">
  <outputColumns>
    <outputColumn id="166" name="Column" description=""
      lineageId="166" precision="0" scale="0"
      length="0" dataType="dbTimeStamp"
      codePage="0" sortKeyPosition="0"
      comparisonFlags="0" specialFlags="0"
      errorOrTruncationOperation=""
      errorRowDisposition="NotUsed"
      truncationRowDisposition="NotUsed"
      externalMetadataColumnId="0">
    <properties>
      <property id="167" name="Attribute Type" dataType=
        "System.String" state="default" isArray=
        "false" description="Time period attribute type"
        typeConverter=
"Microsoft.Samples.SqlServer.Dts.DataFlow.TimeAttributeTypeConverter, CalendarTransform,
Version=1.0.0.0, Culture=neutral, PublicKeyToken=e9fac57941009407"
        UITypeEditor="" containsID="false"
        expressionType="None">Days</property>
      <property id="168" name="Attribute Part" dataType=
        "System.String" state="default" isArray=
        "false" description="Time period attribute part"
        typeConverter=
"Microsoft.Samples.SqlServer.Dts.DataFlow.TimeAttributePartConverter, CalendarTransform,
Version=1.0.0.0, Culture=neutral, PublicKeyToken=e9fac57941009407"
        UITypeEditor="" containsID="false"
        expressionType="None">Key</property>
      <property id="169" name="Format" dataType=

```

```

        "System.String" state="default"
        isArray="false" description=
"Optional format string (output coerced to string)"
        typeConverter="" UITypeEditor=""
        containsID="false" expressionType="None">
    </property>
</properties>
</outputColumn>
</outputColumns>
<externalMetadataColumns isUsed="False"/>
</output>
</outputs>
</component>
<component id="170" name="Flat File Destination"
    componentClassID="{D658C424-8CF0-441C-B3C4-955E183B7FBA}"
    description="Flat File Destination" localeId="1033"
    usesDispositions="false" validateExternalMetadata="True"
    version="0" pipelineVersion="0" contactInfo=
"Flat File Destination;Microsoft Corporation;Microsoft SqlServer v9; (C) 2005 Microsoft
Corporation; All Rights Reserved; http://www.microsoft.com/sql/support;0">
    <properties>
        <property id="173" name="Overwrite" dataType="System.Boolean"
            state="default" isArray="false" description=
"Specifies whether the data will overwrite or append to the destination file."
            typeConverter="" UITypeEditor="" containsID="false"
            expressionType="None">true</property>
        <property id="174" name="Header" dataType="System.Null"
            state="default" isArray="false" description=
"Specifies the text to write to the destination file before any data is written."
            typeConverter="" UITypeEditor="" containsID="false"
            expressionType="Notify"/>
    </properties>
    <connections>
        <connection id="172" name="FlatFileConnection" description=""
            connectionManagerID="{4F717107-732B-4C1B-AAF5-A5A31B6FECE8}"/>
    </connections>
    <inputs>
        <input id="171" name="Flat File Destination Input"
            description="" hasSideEffects="true" dangling="false"
            errorOrTruncationOperation="" errorRowDisposition=
            "NotUsed" truncationRowDisposition="NotUsed">
            <inputColumns>
                <inputColumn id="191" name="" description="" lineageId
                    ="45" usageType="readOnly"
                    errorOrTruncationOperation=""
                    errorRowDisposition="NotUsed"
                    truncationRowDisposition="NotUsed"
                    externalMetadataColumnId="186"/>
                <inputColumn id="192" name="" description=""
                    lineageId="49" usageType="readOnly"
                    errorOrTruncationOperation=""
                    errorRowDisposition="NotUsed"
                    truncationRowDisposition="NotUsed"
                    externalMetadataColumnId="187"/>
                <inputColumn id="193" name="" description=""
                    lineageId="57" usageType="readOnly"
                    errorOrTruncationOperation=""
                    errorRowDisposition="NotUsed"
                    truncationRowDisposition="NotUsed"

```



```

        externalMetadataColumnId="188"/>
    <inputColumn id="194" name="" description=""
        lineageId="129" usageType="readOnly"
        errorOrTruncationOperation=""
        errorRowDisposition="NotUsed"
        truncationRowDisposition="NotUsed"
        externalMetadataColumnId="189"/>
    <inputColumn id="195" name="" description=""
        lineageId="166" usageType="readOnly"
        errorOrTruncationOperation=""
        errorRowDisposition="NotUsed"
        truncationRowDisposition="NotUsed"
        externalMetadataColumnId="190"/>
</inputColumns>
<externalMetadataColumns isUsed="True">
    <externalMetadataColumn id="186" name="Column 0"
        description="" precision="0" scale="0"
        length="0" dataType="r4" codePage="0"/>
    <externalMetadataColumn id="187" name="Column 1"
        description="" precision="0" scale="0"
        length="3" dataType="str" codePage="1252"/>
    <externalMetadataColumn id="188" name="Column 3"
        description="" precision="0" scale="0"
        length="0" dataType="r4" codePage="0"/>
    <externalMetadataColumn id="189" name="DateColumn"
        description="" precision="0" scale="0"
        length="0" dataType="date" codePage="0"/>
    <externalMetadataColumn id="190" name="Column"
        description="" precision="0" scale="0"
        length="0" dataType="dbTimeStamp"
        codePage="0"/>
</externalMetadataColumns>
</input>
</inputs>
</component>
</components>
<paths>
    <path id="61" name="Flat File Source Output"
        description="" startId="21" endId="9"/>
    <path id="180" name="CalendarOutput"
        description="" startId="10" endId="171"/>
</paths>
</pipeline>
</DTS:ObjectData>
</DTS:Executable>
<DTS:Executable DTS:ExecutableType=
"Microsoft.SqlServer.Dts.Tasks.FileSystemTask.FileSystemTask,
Microsoft.SqlServer.FileSystemTask, Version=10.0.0.0, Culture=neutral,
PublicKeyToken=89845dcd8080cc91"
    DTS:ThreadHint="0">
    <DTS:Property DTS:Name="ExecutionLocation">0</DTS:Property>
    <DTS:Property DTS:Name="ExecutionAddress"></DTS:Property>
    <DTS:Property DTS:Name="TaskContact">
File System Task;Microsoft Corporation; Microsoft SQL Server v9; © 2004 Microsoft
Corporation; All Rights
Reserved;http://www.microsoft.com/sql/support/default.asp;1</DTS:Property>
    <DTS:Property DTS:Name="ForceExecValue">0</DTS:Property>
    <DTS:Property DTS:Name="ExecValue" DTS:DataType="3">0</DTS:Property>
    <DTS:Property DTS:Name="ForceExecutionResult">-1</DTS:Property>

```

```

<DTS:Property DTS:Name="Disabled">0</DTS:Property>
<DTS:Property DTS:Name="FailPackageOnFailure">0</DTS:Property>
<DTS:Property DTS:Name="FailParentOnFailure">0</DTS:Property>
<DTS:Property DTS:Name="MaxErrorCount">1</DTS:Property>
<DTS:Property DTS:Name="ISOLevel">1048576</DTS:Property>
<DTS:Property DTS:Name="LocaleID">-1</DTS:Property>
<DTS:Property DTS:Name="TransactionOption">1</DTS:Property>
<DTS:Property DTS:Name="DelayValidation">0</DTS:Property>
<DTS:Property DTS:Name="ObjectName">File Delete Task</DTS:Property>
<DTS:Property DTS:Name="DTSID">{36115195-BDBC-4265-977F-5579CB1542CE}</DTS:Property>
<DTS:Property DTS:Name="Description">File System Task</DTS:Property>
<DTS:Property DTS:Name="CreationName">
Microsoft.SqlServer.Dts.Tasks.FileSystemTask.FileSystemTask,
Microsoft.SqlServer.FileSystemTask, Version=9.0.242.0, Culture=neutral,
PublicKeyToken=89845dcd8080cc91
</DTS:Property>
<DTS:Property DTS:Name="DisableEventHandlers">0</DTS:Property>
<DTS:LoggingOptions>
  <DTS:Property DTS:Name="LoggingMode">0</DTS:Property>
  <DTS:Property DTS:Name="FilterKind">1</DTS:Property>
  <DTS:Property DTS:Name="EventFilter" DTS:DataType="8"></DTS:Property>
</DTS:LoggingOptions>
<DTS:ObjectData>
  <FileSystemData TaskOperationType="DeleteFile" OperationName=""
    TaskOverwriteDestFile="False"
    TaskSourcePath="{00F5DC11-75D6-49FC-BE02-C4984643F39A}"
    TaskIsSourceVariable="False" TaskDestinationPath=""
    TaskIsDestinationVariable="False" TaskFileAttributes="Normal"/>
</DTS:ObjectData>
</DTS:Executable>
<DTS:PrecedenceConstraint>
  <DTS:Property DTS:Name="Value">0</DTS:Property>
  <DTS:Property DTS:Name="EvalOp">2</DTS:Property>
  <DTS:Property DTS:Name="LogicalAnd">-1</DTS:Property>
  <DTS:Property DTS:Name="Expression"></DTS:Property>
  <DTS:Property DTS:Name="ObjectName">Constraint</DTS:Property>
  <DTS:Property DTS:Name="DTSID">
    {ECFD7682-860A-4F39-BF2A-37C0C23C8D39}</DTS:Property>
  <DTS:Property DTS:Name="Description"></DTS:Property>
  <DTS:Property DTS:Name="CreationName"></DTS:Property>
  <DTS:Executable IDREF="{E4168410-1CEC-4CC2-975D-9349F44ABEDB}"
    DTS:IsFrom="-1"/>
  <DTS:Executable IDREF="{23B174F1-23C2-49F9-8512-03D5A2677E67}"
    DTS:IsFrom="0"/>
</DTS:PrecedenceConstraint>
<DTS:PrecedenceConstraint>
  <DTS:Property DTS:Name="Value">0</DTS:Property>
  <DTS:Property DTS:Name="EvalOp">2</DTS:Property>
  <DTS:Property DTS:Name="LogicalAnd">-1</DTS:Property>
  <DTS:Property DTS:Name="Expression"></DTS:Property>
  <DTS:Property DTS:Name="ObjectName">Constraint 1</DTS:Property>
  <DTS:Property DTS:Name="DTSID">{380B124F-4D04-42F1-A9D5-2BA4AF584DB2}</DTS:Property>
  <DTS:Property DTS:Name="Description"></DTS:Property>
  <DTS:Property DTS:Name="CreationName"></DTS:Property>
  <DTS:Executable IDREF="{23B174F1-23C2-49F9-8512-03D5A2677E67}"
    DTS:IsFrom="-1"/>
  <DTS:Executable IDREF="{36115195-BDBC-4265-977F-5579CB1542CE}"

```

```

        DTS:IsFrom="0"/>
    </DTS:PrecedenceConstraint>
    <DTS:PackageVariable>
        <DTS:Property DTS:Name="PackageVariableValue" DTS:DataType="8">
            &lt;TaskHost xmlns:xsd="http://www.w3.org/2001/XMLSchema"
            xmlns:xsi="http://www.w3.org/2001/XMLSchema-instance"
            xmlns:dml2="http://schemas.microsoft.com/analysisisservices/2003/engine/2"
            xmlns:dml2_2="http://schemas.microsoft.com/analysisisservices/2003/engine/2/2"
            xmlns:dwd="http://schemas.microsoft.com/DataWarehouse/Designer/1.0"&gt;&lt;dwd:DtsDataFlowDia
            gram&gt;&lt;dwd:BoundingTop&gt;1000&lt;/dwd:BoundingTop&gt;&lt;dwd:Layout&gt;&lt;dds&gt;
                &lt;diagram fontclsid="{0BE35203-8F91-11CE-9DE3-00AA004BB851}"
                mouseiconclsid="{0BE35204-8F91-11CE-9DE3-00AA004BB851}"
                defaultlayout="Microsoft.DataWarehouse.Layout.GraphLayout"
                defaultlineroute="Microsoft.DataWarehouse.Layout.GraphLayout" version="7" nextobject="15"
                scale="100" pagebreakanchorx="0" pagebreakanchory="0" pagebreaksizex="0" pagebreaksizey="0"
                scrollleft="-1000" scrolltop="0" gridx="150" gridy="150" marginx="1000" marginy="1000"
                zoom="100" x="34131" y="18600" backcolor="15334399" defaultpersistence="2"
                PrintPageNumbersMode="3" PrintMarginTop="0" PrintMarginBottom="635" PrintMarginLeft="0"
                PrintMarginRight="0" marqueeselectionmode="1" mousepointer="0" snaptogrid="0"
                autotypeannotation="1" showscrollbars="0" viewpagebreaks="0"
                donotforceconnectorsbehindshapes="0" backpictureclsid="{00000000-0000-0000-0000-
                000000000000}"&gt;
                    &lt;font&gt;
                    &lt;ddsxmlobjectstreamwrapper binary="01010000900180380100065461686f6d61" /&gt;
                    &lt;/font&gt;
                    &lt;mouseicon&gt;
                    &lt;ddsxmlobjectstreamwrapper binary="6c74000000000000" /&gt;
                    &lt;/mouseicon&gt;
                    &lt;/diagram&gt;
                    &lt;layoutmanager&gt;
                    &lt;ddsxmlobj /&gt;
                    &lt;/layoutmanager&gt;
                    &lt;ddscontrol controlprogid="DdsShapes.DdsObjectManagedBridge.1" tooltip="Generates
                    Roman, financial, reporting, manufacturing and IOS8601 calendar data." left="1587" top="9260"
                    logicalid="6" controlid="1" masterid="0" hint1="0" hint2="0" width="3704" height="1164"
                    noresize="0" nomove="0" nodefaultattachpoints="0" autodrag="1" usedefaultiddshape="1"
                    selectable="1" showselectionhandles="1" allownudging="1" isannotation="0" dontautolayout="0"
                    groupcollapsed="0" tabstop="1" visible="1" snaptogrid="0"&gt;
                        &lt;control&gt;
                        &lt;ddsxmlobjectstreaminitwrapper binary="00080000780e00008c040000" /&gt;
                        &lt;/control&gt;
                        &lt;layoutobject&gt;
                        &lt;ddsxmlobj&gt;
                            &lt;property name="LogicalObject" value="{23B174F1-23C2-49F9-8512-
                            03D5A2677E67}/components/1" vartype="8" /&gt;
                            &lt;property name="ShowConnectorSource" value="0" vartype="2" /&gt;
                            &lt;/ddsxmlobj&gt;
                            &lt;/layoutobject&gt;
                            &lt;shape groupshapeid="0" groupnode="0" /&gt;
                            &lt;/ddscontrol&gt;
                            &lt;ddscontrol controlprogid="DdsShapes.DdsObjectManagedBridge.1" tooltip="Flat File
                            Source" left="0" top="2328" logicalid="7" controlid="2" masterid="0" hint1="0" hint2="0"
                            width="3598" height="1164" noresize="0" nomove="0" nodefaultattachpoints="0" autodrag="1"
                            usedefaultiddshape="1" selectable="1" showselectionhandles="1" allownudging="1"
                            isannotation="0" dontautolayout="0" groupcollapsed="0" tabstop="1" visible="1"
                            snaptogrid="0"&gt;
                                &lt;control&gt;
                                &lt;ddsxmlobjectstreaminitwrapper binary="000800000e0e00008c040000" /&gt;
                                &lt;/control&gt;
                                &lt;layoutobject&gt;
                                &lt;ddsxmlobj&gt;

```

```

    <property name="LogicalObject" value="{23B174F1-23C2-49F9-8512-
03D5A2677E67}/components/20" vartype="8" />
    <property name="ShowConnectorSource" value="0" vartype="2" />
    </ddsxmlobj>
    </layoutobject>
    <shape groupshapeid="0" groupnode="0" />
    </ddscontrol>
    <ddscontrol controlprogid="MSDDS.Polyline" left="1400" top="3093" logicalid="8"
controlid="3" masterid="0" hint1="0" hint2="0" width="2439" height="6667" noresize="0"
nomove="0" nodefaultattachpoints="1" autodrag="0" usedefaultiddshape="0" selectable="1"
showselectionhandles="0" allownudging="1" isannotation="0" dontautolayout="0"
groupcollapsed="0" tabstop="1" visible="1" snaptogrid="0">
    <control>
    <ddsxmlobj>
    <polyline endtypedst="3" endtypesrc="1" usercolor="32768" linestyle="0"
linerender="1" customendtypedstid="0" customendtypesrcid="0" adornsvisible="1" />
    </ddsxmlobj>
    </control>
    </layoutobject>
    <ddsxmlobj>
    <property name="LogicalObject" value="{23B174F1-23C2-49F9-8512-
03D5A2677E67}/paths/61" vartype="8" />
    <property name="Virtual" value="0" vartype="11" />
    <property name="VisibleAP" value="0" vartype="3" />
    </ddsxmlobj>
    </layoutobject>
    <connector lineroutestyle="Microsoft.DataWarehouse.Layout.GraphLayout" sourceid="2"
destid="1" sourceattachpoint="7" destattachpoint="6" segmenteditmode="0"
bendpointeditmode="0" bendpointvisibility="2" relatedid="0" virtual="0">
    <point x="1799" y="3492" />
    <point x="1799" y="6376" />
    <point x="3439" y="6376" />
    <point x="3439" y="9260" />
    </connector>
    </ddscontrol>
    <ddscontrol controlprogid="DdsShapes.DdsObjectManagedBridge.1" tooltip="Flat File
Destination" left="4366" top="13944" logicalid="9" controlid="4" masterid="0" hint1="0"
hint2="0" width="3598" height="1164" noresize="0" nomove="0" nodefaultattachpoints="0"
autodrag="1" usedefaultiddshape="1" selectable="1" showselectionhandles="1" allownudging="1"
isannotation="0" dontautolayout="0" groupcollapsed="0" tabstop="1" visible="1"
snaptogrid="0">
    <control>
    <ddsxmlobjectstreaminitwrapper binary="000800000e0e00008c040000" />
    </control>
    </layoutobject>
    <ddsxmlobj>
    <property name="LogicalObject" value="{23B174F1-23C2-49F9-8512-
03D5A2677E67}/components/170" vartype="8" />
    <property name="ShowConnectorSource" value="0" vartype="2" />
    </ddsxmlobj>
    </layoutobject>
    <shape groupshapeid="0" groupnode="0" />
    </ddscontrol>
    <ddscontrol controlprogid="MSDDS.Polyline" left="3040" top="10025" logicalid="10"
controlid="5" masterid="0" hint1="0" hint2="0" width="3525" height="4419" noresize="0"
nomove="0" nodefaultattachpoints="1" autodrag="0" usedefaultiddshape="0" selectable="1"
showselectionhandles="0" allownudging="1" isannotation="0" dontautolayout="0"
groupcollapsed="0" tabstop="1" visible="1" snaptogrid="0">
    <control>
    <ddsxmlobj>

```

```

        <polyline endtypedst="3" endtypesrc="1" usercolor="32768" linestyle="0"
linerender="1" customendtypedstid="0" customendtypesrcid="0" adornsvisible="1" />
        </ddsxmlobj>
        </control>
        </layoutobject>
        </ddsxmlobj>
        <property name="LogicalObject" value="{23B174F1-23C2-49F9-8512-
03D5A2677E67}/paths/180" vartype="8" />
        <property name="Virtual" value="0" vartype="11" />
        <property name="VisibleAP" value="0" vartype="3" />
        </ddsxmlobj>
        </layoutobject>
        <connector lineroutestyle="Microsoft.DataWarehouse.Layout.GraphLayout" sourceid="1"
destid="4" sourceattachpoint="7" destattachpoint="6" segmentededitmode="0"
bendpointeditmode="0" bendpointvisibility="2" relatedid="0" virtual="0">
        <point x="3439" y="10424" />
        <point x="3439" y="12184" />
        <point x="6165" y="12184" />
        <point x="6165" y="13944" />
        </connector>
        </ddscontrol>
        </dds>
        </dwd:Layout>
        </dwd:PersistedViewPortLeft>
        </dwd:PersistedViewPortLeft>
        </dwd:DtsDataFlowDiagram>
        </TaskHost>
    </DTS:Property>
    <DTS:Property DTS:Name="Namespace">dts-designer-1.0</DTS:Property>
    <DTS:Property DTS:Name="ObjectName">
        {23B174F1-23C2-49F9-8512-03D5A2677E67}</DTS:Property>
    <DTS:Property DTS:Name="DTSID">
        {4E58A203-3C53-415B-AC2D-8E70958FDA9C}</DTS:Property>
    <DTS:Property DTS:Name="Description"></DTS:Property>
    <DTS:Property DTS:Name="CreationName"></DTS:Property>
</DTS:PackageVariable>
<DTS:PackageVariable>
    <DTS:Property DTS:Name="PackageVariableValue" DTS:DataType="8">
        <PipelinePath xmlns:xsd="http://www.w3.org/2001/XMLSchema"
xmlns:xsi="http://www.w3.org/2001/XMLSchema-instance"
xmlns:ddl2="http://schemas.microsoft.com/analysisisservices/2003/engine/2"
xmlns:ddl2_2="http://schemas.microsoft.com/analysisisservices/2003/engine/2/2"
xmlns:dwd="http://schemas.microsoft.com/DataWarehouse/Designer/1.0">
        <dwd:DestinationName>Flat File Destination
Input</dwd:DestinationName>
        <dwd:SourceName>CalendarOutput</dwd:SourceName>
        </PipelinePath>
    </DTS:Property>
    <DTS:Property DTS:Name="Namespace">dts-designer-1.0</DTS:Property>
    <DTS:Property DTS:Name="ObjectName">{23B174F1-23C2-49F9-8512-03D5A2677E67}-
180</DTS:Property>
    <DTS:Property DTS:Name="DTSID">{39EC5E29-C552-4771-A608-54CD23A218E8}</DTS:Property>
    <DTS:Property DTS:Name="Description"></DTS:Property>
    <DTS:Property DTS:Name="CreationName"></DTS:Property>
</DTS:PackageVariable>
<DTS:PackageVariable>
    <DTS:Property DTS:Name="PackageVariableValue" DTS:DataType="8">
        <PipelinePath xmlns:xsd="http://www.w3.org/2001/XMLSchema"
xmlns:xsi="http://www.w3.org/2001/XMLSchema-instance"
xmlns:ddl2="http://schemas.microsoft.com/analysisisservices/2003/engine/2"
xmlns:ddl2_2="http://schemas.microsoft.com/analysisisservices/2003/engine/2/2"
xmlns:dwd="http://schemas.microsoft.com/DataWarehouse/Designer/1.0">
        <dwd:DestinationName>CalendarInput</dwd:DestinationName>
        <dwd:SourceName>Flat File Source
Output</dwd:SourceName>
        </PipelinePath>
    </DTS:Property>

```

```

</DTS:Property>
<DTS:Property DTS:Name="Namespace">dts-designer-1.0</DTS:Property>
<DTS:Property DTS:Name="ObjectName">
  {23B174F1-23C2-49F9-8512-03D5A2677E67}-61</DTS:Property>
<DTS:Property DTS:Name="DTSID">
  {2C2FBCB9-7EC6-4D0A-A352-0323E0EBE5E6}</DTS:Property>
<DTS:Property DTS:Name="Description"></DTS:Property>
<DTS:Property DTS:Name="CreationName"></DTS:Property>
</DTS:PackageVariable>
<DTS:PackageVariable>
  <DTS:Property DTS:Name="PackageVariableValue" DTS:DataType="8">
    &lt;PrecedenceConstraint xmlns:xsd="http://www.w3.org/2001/XMLSchema"
xmlns:xsi="http://www.w3.org/2001/XMLSchema-instance"
xmlns:ddl2="http://schemas.microsoft.com/analysisisservices/2003/engine/2"
xmlns:ddl2_2="http://schemas.microsoft.com/analysisisservices/2003/engine/2/2"
xmlns:dwd="http://schemas.microsoft.com/DataWarehouse/Designer/1.0"&gt;&lt;dw:EvalOp&gt;Cons
traint&lt;/dw:EvalOp&gt;&lt;/PrecedenceConstraint&gt;
  </DTS:Property>
  <DTS:Property DTS:Name="Namespace">dts-designer-1.0</DTS:Property>
  <DTS:Property DTS:Name="ObjectName">
    {380B124F-4D04-42F1-A9D5-2BA4AF584DB2}</DTS:Property>
  <DTS:Property DTS:Name="DTSID">
    {70E7F0E0-0650-48D3-AD12-02695CEFE9B4}</DTS:Property>
  <DTS:Property DTS:Name="Description"></DTS:Property>
  <DTS:Property DTS:Name="CreationName"></DTS:Property>
</DTS:PackageVariable>
<DTS:PackageVariable>
  <DTS:Property DTS:Name="PackageVariableValue" DTS:DataType="8">
    &lt;Package xmlns:xsd="http://www.w3.org/2001/XMLSchema"
xmlns:xsi="http://www.w3.org/2001/XMLSchema-instance"
xmlns:ddl2="http://schemas.microsoft.com/analysisisservices/2003/engine/2"
xmlns:ddl2_2="http://schemas.microsoft.com/analysisisservices/2003/engine/2/2"
xmlns:dwd="http://schemas.microsoft.com/DataWarehouse/Designer/1.0"&gt;&lt;dw:DtsControlFlow
Diagram&gt;&lt;dw:BoundingLeft&gt;1000&lt;/dw:BoundingLeft&gt;&lt;dw:BoundingTop&gt;1000&lt;
t;/dw:BoundingTop&gt;&lt;dw:Layout&gt;&lt;dds&gt;
    &lt;diagram fontclsid="{0BE35203-8F91-11CE-9DE3-00AA004BB851}"
mouseiconclsid="{0BE35204-8F91-11CE-9DE3-00AA004BB851}"
defaultlayout="Microsoft.DataWarehouse.Layout.GraphLayout"
defaultlineroute="Microsoft.DataWarehouse.Layout.GraphLayout" version="7" nextobject="11"
scale="100" pagebreakanchorx="0" pagebreakanchory="0" pagebreaksizex="0" pagebreaksizey="0"
scrollleft="0" scrolltop="0" gridx="150" gridy="150" marginx="1000" marginy="1000" zoom="100"
x="34131" y="19526" bgcolor="15334399" defaultpersistence="2" PrintPageNumbersMode="3"
PrintMarginTop="0" PrintMarginBottom="635" PrintMarginLeft="0" PrintMarginRight="0"
marqueeselectionmode="1" mousepointer="0" snaptogrid="0" autotypeannotation="1"
showscrollbars="0" viewpagebreaks="0" donotforceconnectorsbehindshapes="1"
backpictureclsid="{00000000-0000-0000-0000-000000000000}"&gt;
    &lt;font&gt;
    &lt;ddsxmlobjectstreamwrapper binary="01010000900180380100065461686f6d61" /&gt;
    &lt;/font&gt;
    &lt;mouseicon&gt;
    &lt;ddsxmlobjectstreamwrapper binary="6c74000000000000" /&gt;
    &lt;/mouseicon&gt;
    &lt;/diagram&gt;
    &lt;layoutmanager&gt;
    &lt;ddsxmlobj /&gt;
    &lt;/layoutmanager&gt;
    &lt;ddscontrol controlprogid="DdsShapes.DdsObjectManagedBridge.1" tooltip="Data Flow
Task" left="3677" top="4095" logicalid="2" controlid="1" masterid="0" hint1="0" hint2="0"
width="3598" height="1164" noresize="0" nomove="0" nodefaultattachpoints="0" autodrag="1"
usedefaulttiddshape="1" selectable="1" showselectionhandles="1" allownudging="1"

```

```

isannotation="0" dontautolayout="0" groupcollapsed="0" tabstop="1" visible="1"
snaptogrid="0">
  <control>
    <ddsxmlobjectstreaminitwrapper binary="000800000e0e00008c040000" />
  </control>
  <layoutobject>
    <ddsxmlobj>
      <property name="LogicalObject" value="{23B174F1-23C2-49F9-8512-03D5A2677E67}"
vartype="8" />
      <property name="ShowConnectorSource" value="0" vartype="2" />
    </ddsxmlobj>
  </layoutobject>
  <shape groupshapeid="0" groupnode="0" />
  <ddscontrol>
    <ddscontrol controlprogid="DdsShapes.DdsObjectManagedBridge.1"
tooltip="CustomFileCopyTask" left="3386" top="1032" logicalid="5" controlid="4" masterid="0"
hint1="0" hint2="0" width="3598" height="1164" noresize="0" nomove="0"
nodefaultattachpoints="0" autodrag="1" usedefaultiddshape="1" selectable="1"
showselectionhandles="1" allownudging="1" isannotation="0" dontautolayout="0"
groupcollapsed="0" tabstop="1" visible="1" snaptogrid="0">
      <control>
        <ddsxmlobjectstreaminitwrapper binary="000800000e0e00008c040000" />
      </control>
      <layoutobject>
        <ddsxmlobj>
          <property name="LogicalObject" value="{E4168410-1CEC-4CC2-975D-9349F44ABEDB}"
vartype="8" />
          <property name="ShowConnectorSource" value="0" vartype="2" />
        </ddsxmlobj>
      </layoutobject>
      <shape groupshapeid="0" groupnode="0" />
      <ddscontrol>
        <ddscontrol controlprogid="DdsShapes.DdsObjectManagedBridge.1" tooltip="File System
Task" left="3678" top="8334" logicalid="7" controlid="6" masterid="0" hint1="0" hint2="0"
width="3598" height="1164" noresize="0" nomove="0" nodefaultattachpoints="0" autodrag="1"
usedefaultiddshape="1" selectable="1" showselectionhandles="1" allownudging="1"
isannotation="0" dontautolayout="0" groupcollapsed="0" tabstop="1" visible="1"
snaptogrid="0">
          <control>
            <ddsxmlobjectstreaminitwrapper binary="000800000e0e00008c040000" />
          </control>
          <layoutobject>
            <ddsxmlobj>
              <property name="LogicalObject" value="{36115195-BDBC-4265-977F-5579CB1542CE}"
vartype="8" />
              <property name="ShowConnectorSource" value="0" vartype="2" />
            </ddsxmlobj>
          </layoutobject>
          <shape groupshapeid="0" groupnode="0" />
          <ddscontrol>
            <ddscontrol controlprogid="MSDDS.Polyline" left="4786" top="1797" logicalid="9"
controlid="8" masterid="0" hint1="0" hint2="0" width="1090" height="2798" noresize="0"
nomove="0" nodefaultattachpoints="1" autodrag="0" usedefaultiddshape="0" selectable="1"
showselectionhandles="0" allownudging="1" isannotation="0" dontautolayout="0"
groupcollapsed="0" tabstop="1" visible="1" snaptogrid="0">
              <control>
                <ddsxmlobj>
                  <polyline endtypedst="3" endtypesrc="1" usercolor="32768" linestyle="0"
linerender="2" customendtypedstid="0" customendtypesrcid="0" adornsvisible="1" />
                </ddsxmlobj>
              </control>
            </ddscontrol>
          </shape>
        </ddscontrol>
      </shape>
    </ddscontrol>
  </shape>

```

```

        <layoutobject>
        <ddsxmlobj>
        <property name="LogicalObject" value="{ECFD7682-860A-4F39-BF2A-37C0C23C8D39}"
vartype="8" />
        <property name="Virtual" value="0" vartype="11" />
        <property name="VisibleAP" value="0" vartype="3" />
        </ddsxmlobj>
        </layoutobject>
        <connector lineroutestyle="Microsoft.DataWarehouse.Layout.GraphLayout" sourceid="4"
destid="1" sourceattachpoint="7" destattachpoint="6" segmenteditmode="0"
bendpointeditmode="0" bendpointvisibility="2" relatedid="0" virtual="0">
        <point x="5185" y="2196" />
        <point x="5185" y="3145" />
        <point x="5476" y="3145" />
        <point x="5476" y="4095" />
        </connector>
        </ddscontrol>
        <ddscontrol controlprogid="MSDDS.Polyline" left="5077" top="4860" logicalid="10"
controlid="9" masterid="0" hint1="0" hint2="0" width="800" height="3974" noresize="0"
nomove="0" nodefaultattachpoints="1" autodrag="0" usedefaultiddshape="0" selectable="1"
showselectionhandles="0" allownudging="1" isannotation="0" dontautolayout="0"
groupcollapsed="0" tabstop="1" visible="1" snaptogrid="0">
        <control>
        <ddsxmlobj>
        <polyline endtypedst="3" endtypesrc="1" usercolor="32768" linestyle="0"
linerender="2" customendtypedstid="0" customendtypesrcid="0" adornsvisible="1" />
        </ddsxmlobj>
        </control>
        </layoutobject>
        <ddsxmlobj>
        <property name="LogicalObject" value="{380B124F-4D04-42F1-A9D5-2BA4AF584DB2}"
vartype="8" />
        <property name="Virtual" value="0" vartype="11" />
        <property name="VisibleAP" value="0" vartype="3" />
        </ddsxmlobj>
        </layoutobject>
        <connector lineroutestyle="Microsoft.DataWarehouse.Layout.GraphLayout" sourceid="1"
destid="6" sourceattachpoint="7" destattachpoint="6" segmenteditmode="0"
bendpointeditmode="0" bendpointvisibility="2" relatedid="0" virtual="0">
        <point x="5476" y="5259" />
        <point x="5476" y="6796" />
        <point x="5477" y="6796" />
        <point x="5477" y="8334" />
        </connector>
        </ddscontrol>
        </dds> </dwd:Layout> </dwd:DtsControlFlowDiagram> </Package>
</DTS:Property>
<DTS:Property DTS:Name="Namespace">dts-designer-1.0</DTS:Property>
<DTS:Property DTS:Name="ObjectName">
  {61EDFABA-B54F-4EFE-9FF2-DABDD94B9D51}</DTS:Property>
<DTS:Property DTS:Name="DTSID">
  {05D4BDFA-476A-4364-AF28-B7E789B5B5C4}</DTS:Property>
<DTS:Property DTS:Name="Description"></DTS:Property>
<DTS:Property DTS:Name="CreationName"></DTS:Property>
</DTS:PackageVariable>
<DTS:PackageVariable>
  <DTS:Property DTS:Name="PackageVariableValue" DTS:DataType="8">
    <PrecedenceConstraint xmlns:xsd="http://www.w3.org/2001/XMLSchema"
xmlns:xsi="http://www.w3.org/2001/XMLSchema-instance"
xmlns:ddl2="http://schemas.microsoft.com/analysisisservices/2003/engine/2"

```



```
xmlns:ddl2_2="http://schemas.microsoft.com/analysiservices/2003/engine/2/2"
xmlns:dwd="http://schemas.microsoft.com/DataWarehouse/Designer/1.0">< <dwd:EvalOp><Constraint<</dwd:EvalOp>< </PrecedenceConstraint>
  </DTS:Property>
  <DTS:Property DTS:Name="Namespace">dts-designer-1.0</DTS:Property>
  <DTS:Property DTS:Name="ObjectName">
    {ECFD7682-860A-4F39-BF2A-37C0C23C8D39}</DTS:Property>
  <DTS:Property DTS:Name="DTSID">
    {0F16D98D-E992-4013-AFB9-179B19A88AAE}</DTS:Property>
  <DTS:Property DTS:Name="Description"></DTS:Property>
  <DTS:Property DTS:Name="CreationName"></DTS:Property>
</DTS:PackageVariable>
</DTS:Executable>
```

4 Security

4.1 Security Considerations for Implementers

DTSX is a clear-text XML format. Therefore, all information that is persisted into the DTSX structure can be read by any person who has access to the file or who gains access to the file, even if such access was not intended. The security of the information can be increased by various methods, including the following:

- Restrict access to the file through use of access control lists (ACLs) or other methods.
- Set the **ProtectionLevel** property to a level that encrypts or hides sensitive information that is contained in the package file. For more information, see [ExecutableTypePackagePropertyNameEnum](#).
 - The value "0" for the **ProtectionLevel** property causes sensitive information to be excluded from package file storage.
 - The values "1" and "4" for the **ProtectionLevel** property cause sensitive information to be encrypted with a user key.
 - The values "2" and "3" for the **ProtectionLevel** property cause sensitive information to be encrypted with a password.
- Omit or encrypt specific element information, such as connection strings and passwords, from any file that is in DTSX format before it is persisted. At run time, a user interface can prompt for a password to access encrypted information or can prompt for the entry of omitted information that was not persisted in the file.

4.1.1 Encryption Implementation for Settings in the ProtectionLevel Property

Depending on the value that is selected for the **ProtectionLevel** property, one of two encryption algorithms is used: encryption with a user key or encryption with a password.

4.1.1.1 Encryption with User Key

If the **ProtectionLevel** property is set to the values "1" or "4", information is encrypted with a user key. The encryption is implemented by a call to the **CryptProtectData** function [\[MSDN-CryptProtectData\]](#). The **CryptProtectData** function operates by including a key within the storage binary large object (BLOB) that opens and decrypts the persisted data only for a user who has the same credentials that were used to store the encrypted data.

4.1.1.2 Encryption with Password

If the **ProtectionLevel** property is set to the values "2" or "3", information is encrypted with a password. When information is encrypted with a password, the encryption algorithm that is used is the XML Encryption standard [\[XMLEncryptSyntax\]](#).

4.2 Index of Security Fields

Security field	Section
ProtectionLevel property	ExecutableTypePackagePropertyNameEnum

Security field	Section
PackagePassword property	ExecutePackageTaskObjectDataType
PasswordElementType type	PasswordElementType
Sensitive attribute	FtpConnectionType HttpConnectionType DMQueryTaskQueryStringContainerType DMQueryBuilderSpecificationType PasswordElementType
Encrypted attribute	FtpConnectionType HttpConnectionType DMQueryTaskQueryStringContainerType DMQueryBuilderSpecificationType PasswordElementType

5 Appendix A: Full DTSX XSD

For ease of implementation, the following sections provide the full DTSX syntax for this file format.

DTSX syntax	Section
DTS	5.1
WebServiceTask	5.2
MessageQueueTask	5.3
SendMailTask	5.4
ActiveXScriptTask	5.5
Exec80PackageTask	5.6
BulkInsertTask	5.7
SQLTask	5.8

5.1 DTS XSD

```
<?xml version="1.0" encoding="utf-8"?>
<xs:schema xmlns:DTS="www.microsoft.com/SqlServer/Dts"
  xmlns:xs="http://www.w3.org/2001/XMLSchema"
  elementFormDefault="qualified"
  attributeFormDefault="qualified"
  targetNamespace="www.microsoft.com/SqlServer/Dts"
  xmlns:WSTask="www.microsoft.com/sqlserver/dts/tasks/webservicetask"
  xmlns:MessageQueueTask="www.microsoft.com/sqlserver/dts/tasks/messagequeuetask"
  xmlns:SendMailTask="www.microsoft.com/sqlserver/dts/tasks/sendmailtask"
  xmlns:ActiveXScriptTask=
    "www.microsoft.com/sqlserver/dts/tasks/activexscripttask"
  xmlns:Exec80PackageTask=
    "www.microsoft.com/sqlserver/dts/tasks/exec80packagetask"
  xmlns:BulkInsertTask=
    "www.microsoft.com/sqlserver/dts/tasks/bulkinserttask"
  xmlns:SQLTask="www.microsoft.com/sqlserver/dts/tasks/sqltask"
  >

  <!--Imports-->

  <xs:import namespace=
    "www.microsoft.com/sqlserver/dts/tasks/webservicetask"
    schemaLocation="./ns_webservicetask.xsd" />
  <xs:import namespace=
    "www.microsoft.com/sqlserver/dts/tasks/messagequeuetask"
    schemaLocation="./ns_messagequeuetask.xsd" />
  <xs:import namespace=
    "www.microsoft.com/sqlserver/dts/tasks/sendmailtask"
    schemaLocation="./ns_sendmailtask.xsd" />
  <xs:import namespace=
    "www.microsoft.com/sqlserver/dts/tasks/activexscripttask"
    schemaLocation="./ns_activexscripttask.xsd" />
  <xs:import namespace=
```

```

    "www.microsoft.com/sqlserver/dts/tasks/exec80packagetask"
    schemaLocation=". /ns_exec80packagetask.xsd" />
<xs:import namespace=
    "www.microsoft.com/sqlserver/dts/tasks/bulkinserttask"
    schemaLocation=". /ns_bulkinserttask.xsd" />
<xs:import namespace=
    "www.microsoft.com/sqlserver/dts/tasks/sqltask"
    schemaLocation=". /ns_sqltask.xsd" />

<!--Root Element and Root Executables-->

<xs:element name="Executable" type="DTS:ExecutableTypePackage"/>

<xs:complexType name="ExecutableTypePackage">
  <xs:sequence>
    <xs:element name="Property" maxOccurs="unbounded">
      <xs:complexType>
        <xs:complexContent>
          <xs:extension base="DTS:PropertyElementBaseType">
            <xs:attribute name="Name"
              type="DTS:ExecutableTypePackagePropertyNameEnum"
              use="required"/>
          </xs:extension>
        </xs:complexContent>
      </xs:complexType>
    </xs:element>
    <xs:element name="ConnectionManagers" type="DTS:ConnectionManagersType"
      minOccurs="0"/>
    <xs:element name="Configurations" type="DTS:ConfigurationsType"
      minOccurs="0"/>
    <xs:element name="LogProviders" type="DTS:LogProvidersType"
      minOccurs="0"/>
    <xs:element name="Variables" type="DTS:VariablesType"
      minOccurs="0"/>
    <xs:element name="LoggingOptions" type="DTS:LoggingOptionsType" minOccurs="0"/>
    <xs:element name="PropertyExpression"
      type="DTS:PropertyExpressionElementType"
      minOccurs="0" maxOccurs="unbounded"/>
    <xs:element name="Executables" type="DTS:ExecutablesType"
      minOccurs="0"/>
    <xs:element name="PrecedenceConstraints" minOccurs="0"
      type="DTS:PrecedenceConstraintsType"/>
    <xs:element name="EventHandlers" type="DTS:EventHandlersType"
      minOccurs="0"/>
    <xs:element name="PackageParameters" type="DTS:PackageParametersType"
      minOccurs="0" />
    <xs:element name="PackageVariables" type="DTS:PackageVariablesType"
      minOccurs="0" maxOccurs="unbounded"/>
    <xs:element name="DesignTimeProperties" type="xs:string"
      minOccurs="0"/>
  </xs:sequence>
  <xs:attribute name="ExecutableType" use="required"
    fixed="SSIS.Package.3" />
  <xs:attribute name="refId" type="xs:string" use="required"
    form="qualified"/>
  <xs:attributeGroup ref="DTS:AllExecutableAttributeGroup"/>
  <xs:attributeGroup ref="DTS:BaseExecutablePropertyAttributeGroup"/>
  <xs:attributeGroup ref="DTS:BasePropertyAttributeGroup"/>

```

```

    <xs:attributeGroup ref="DTS:ExecutableTypePackageAttributeGroup"/>
  </xs:complexType>

<xs:complexType name="ExecutablesType">
  <xs:sequence>
    <xs:element name="Executable" type="DTS:AnyNonPackageExecutableType"
      minOccurs="0" maxOccurs="unbounded"/>
  </xs:sequence>
</xs:complexType>

<xs:complexType name="AnyNonPackageExecutableType">
  <xs:sequence>
    <xs:element name="ForEachEnumerator"
      type="DTS:ForEachEnumeratorType" minOccurs="0"/>
    <xs:element name="Variables" type="DTS:VariablesType"
      minOccurs="0"/>
    <xs:element name="LoggingOptions" type="DTS:LoggingOptionsType"
      minOccurs="0"/>
    <xs:element name="PropertyExpression"
      type="DTS:PropertyExpressionElementType"
      minOccurs="0" maxOccurs="unbounded"/>
    <xs:element name="Executables" type="DTS:ExecutablesType"
      minOccurs="0"/>
    <xs:element name="PrecedenceConstraints"
      type="DTS:PrecedenceConstraintsType"
      minOccurs="0"/>
    <xs:element name="ForEachVariableMappings"
      type="DTS:ForEachVariableMappingType" minOccurs="0"/>
    <xs:element name="EventHandlers" type="DTS:EventHandlersType"
      minOccurs="0"/>
    <xs:element name="ObjectData" type="DTS:ExecutableObjectDataType"
      minOccurs="0"/>
  </xs:sequence>
  <xs:attribute name="ExecutableType" use="required"
    type="DTS:AnyNonPackageExecutableTypeExecutableTypeEnum"/>
  <xs:attribute name="ThreadHint" use="optional" type="xs:int"/>
  <xs:attributeGroup ref="DTS:AllExecutableAttributeGroup"/>
  <xs:attributeGroup ref="DTS:BaseExecutablePropertyAttributeGroup"/>
  <xs:attributeGroup ref="DTS:BasePropertyAttributeGroup"/>
  <xs:attributeGroup ref="DTS:AnyNonPackageExecutableAttributeGroup"/>
  <xs:attribute name="refId" type="xs:string" use="required"
    form="qualified"/>
</xs:complexType>

<!--Package Exe contained types-->

<xs:complexType name="PackageParametersType">
  <xs:sequence>
    <xs:element name="PackageParameter" type="DTS:PackageParameterType" minOccurs="0"
      maxOccurs="unbounded" />
  </xs:sequence>
</xs:complexType>

<xs:complexType name="PackageParameterType">
  <xs:sequence>
    <xs:element maxOccurs="unbounded" name="Property"
      type="DTS:PackageParameterPropertyType" />
  </xs:sequence>
  <xs:attribute name="CreationName" use="required" type="xs:string" />

```

```

    <xs:attribute name="DataType" type="xs:unsignedByte" use="required" />
    <xs:attribute name="Description" type="xs:string" use="optional" />
    <xs:attribute name="DTSID" type="DTS:uuid" use="required" />
    <xs:attribute name="ObjectName" type="xs:string" use="required" />
    <xs:attribute name="Required" type="xs:string" use="optional" />
    <xs:attribute name="Sensitive" type="xs:string" use="optional" />
</xs:complexType>

<xs:complexType mixed="true" name="PackageParameterPropertyType">
  <xs:sequence minOccurs="0">
    <xs:element name="Property"
      type="DTS:PackageParameterPropertyEncryptedValuePropertyType" />
  </xs:sequence>
  <xs:attribute name="DataType" type="xs:unsignedByte" use="optional" />
  <xs:attribute name="Name" type="xs:string" use="required" />
</xs:complexType>

<xs:complexType name="PackageParameterPropertyEncryptedValuePropertyType">
  <xs:simpleContent>
    <xs:extension base="xs:string">
      <xs:attribute name="DataType" type="xs:unsignedByte" use="required" />
      <xs:attribute name="Name" type="xs:string" use="required" />
      <xs:attribute name="Encrypted" type="xs:unsignedByte" use="required" />
    </xs:extension>
  </xs:simpleContent>
</xs:complexType>
<xs:complexType name="PackageVariablesType">
  <xs:sequence>
    <xs:element name="PackageVariable" type="DTS:PackageVariableType"
      minOccurs="0" maxOccurs="unbounded" form="qualified"/>
  </xs:sequence>
</xs:complexType>

<xs:complexType name="PackageVariableType">
  <xs:sequence>
    <xs:element name="Property"
      maxOccurs="unbounded">
      <xs:complexType>
        <xs:complexContent>
          <xs:extension base="DTS:PropertyElementBaseType">
            <xs:attribute name="Name"
              type="DTS:PackageVariablePropertyNameEnum"
              use="required"/>
          </xs:extension>
        </xs:complexContent>
      </xs:complexType>
    </xs:element>
    <xs:element name="PropertyExpression"
      type="DTS:PropertyExpressionElementType"
      minOccurs="0" maxOccurs="unbounded"/>
  </xs:sequence>
</xs:complexType>

<xs:complexType name="ConfigurationsType">
  <xs:sequence>
    <xs:element name="Configuration" type="DTS:ConfigurationType"
      minOccurs="0" maxOccurs="unbounded" form="qualified"/>
  </xs:sequence>
</xs:complexType>

```

```

<xs:complexType name="ConfigurationType">
  <xs:sequence>
    <xs:element name="PropertyExpression"
      type="DTS:PropertyExpressionElementType"
      minOccurs="0" maxOccurs="unbounded"/>
  </xs:sequence>
  <xs:attributeGroup ref="DTS:BasePropertyAttributeGroup"/>
  <xs:attributeGroup ref="DTS:ConfigurationAttributeGroup"/>
</xs:complexType>

<xs:complexType name="LogProvidersType">
  <xs:sequence>
    <xs:element name="LogProvider" type="DTS:LogProviderType"
      minOccurs="0" maxOccurs="unbounded" form="qualified"/>
  </xs:sequence>
</xs:complexType>

<xs:complexType name="LogProviderType" >
  <xs:sequence>
    <xs:element name="PropertyExpression"
      type="DTS:PropertyExpressionElementType"
      minOccurs="0" maxOccurs="unbounded"/>
    <xs:element name="ObjectData" type="DTS:LogProviderObjectDataType"/>
  </xs:sequence>
  <xs:attributeGroup ref="DTS:BasePropertyAttributeGroup"/>
  <xs:attributeGroup ref="DTS:LogProviderAttributeGroup"/>
</xs:complexType>

<xs:complexType name="ConnectionManagersType">
  <xs:sequence>
    <xs:element name="ConnectionManager" type="DTS:ConnectionManagerType"
      minOccurs="0" maxOccurs="unbounded" form="qualified"/>
  </xs:sequence>
</xs:complexType>

<xs:complexType name="ConnectionManagerType">
  <xs:sequence>
    <xs:element name="PropertyExpression"
      type="DTS:PropertyExpressionElementType"
      minOccurs="0" maxOccurs="unbounded"/>
    <xs:element name="ObjectData"
      type="DTS:ConnectionManagerObjectDataType"/>
  </xs:sequence>
  <xs:attributeGroup ref="DTS:BasePropertyAttributeGroup"/>
  <xs:attributeGroup ref="DTS:ConnectionManagerAttributeGroup"/>
  <xs:attribute name="refId" type="xs:string" use="required"
    form="qualified"/>
</xs:complexType>

<!--AnyNonPackageExecutable Contained Complex Types-->

<xs:complexType name="PrecedenceConstraintsType">
  <xs:sequence>
    <xs:element name="PrecedenceConstraint"
      type="DTS:PrecedenceConstraintType"
      minOccurs="0" maxOccurs="unbounded"/>
  </xs:sequence>
</xs:complexType>

```



```

<xs:complexType name="PrecedenceConstraintType">
  <xs:sequence>
    <xs:element name="PropertyExpression"
      type="DTS:PropertyExpressionElementType"
      minOccurs="0" maxOccurs="unbounded"/>
  </xs:sequence>
  <xs:attributeGroup ref="DTS:BasePropertyAttributeGroup"/>
  <xs:attributeGroup ref="DTS:PrecedenceConstraintAttributeGroup"/>
  <xs:attribute name="refId" type="xs:string" use="required"
    form="qualified"/>
</xs:complexType>

<xs:complexType name="LoggingOptionsType">
  <xs:sequence>
    <xs:element name="Property"
      type="DTS:LoggingOptionsPropertyElementType"
      minOccurs="0" maxOccurs="unbounded">
    </xs:element>
    <xs:element name="PropertyExpression"
      type="DTS:PropertyExpressionElementType"
      minOccurs="0" maxOccurs="unbounded"/>
    <xs:element name="SelectedLogProviders" minOccurs="0"
      type="DTS:SelectedLogProvidersType"/>
  </xs:sequence>
  <xs:attributeGroup ref="DTS:LoggingOptionsAttributeGroup"/>
</xs:complexType>

<xs:complexType name="LoggingOptionsPropertyElementType" mixed="true">
  <xs:sequence>
    <xs:element name="Property" minOccurs="0" maxOccurs="unbounded">
      <xs:complexType>
        <xs:simpleContent>
          <xs:extension base="xs:anySimpleType">
            <xs:attribute name="Name"
              type="DTS:ColumnEventFilterPropertyNameEnum"
              use="required"/>
            <xs:attribute name="DataType" type="DTS:DtsDataTypeEnum"/>
          </xs:extension>
        </xs:simpleContent>
      </xs:complexType>
    </xs:element>
  </xs:sequence>
  <xs:attribute name="Name"
    type="DTS:LoggingOptionsPropertyNameEnum"
    use="required"/>
  <xs:attribute name="DataType" type="DTS:DtsDataTypeEnum"/>
  <xs:attribute name="EventName" type="xs:string"/>
</xs:complexType>

<xs:complexType name="SelectedLogProviderTypeX">
  <xs:simpleContent>
    <xs:extension base="xs:anySimpleType">
      <xs:attribute name="InstanceID" type="DTS:uuid"/>
    </xs:extension>
  </xs:simpleContent>
</xs:complexType>

<xs:complexType name="SelectedLogProvidersType">

```

```

<xs:sequence>
  <xs:element name="SelectedLogProvider"
    type="DTS:SelectedLogProviderType"
    minOccurs="0" maxOccurs="unbounded"/>
</xs:sequence>
</xs:complexType>

<xs:complexType name="SelectedLogProviderType">
  <xs:sequence/>
  <xs:attribute name="InstanceID" type="DTS:uuid"/>
</xs:complexType>

<xs:complexType name="VariablesType">
  <xs:sequence>
    <xs:element name="Variable" type="DTS:VariableType"
      minOccurs="0" maxOccurs="unbounded"/>
  </xs:sequence>
</xs:complexType>

<xs:complexType name="VariableType">
  <xs:sequence>
    <xs:element name="PropertyExpression"
      type="DTS:PropertyExpressionElementType"
      minOccurs="0" maxOccurs="unbounded"/>
    <xs:element name="VariableValue">
      <xs:complexType mixed="true">
        <xs:sequence>
          <xs:any minOccurs="0" maxOccurs="unbounded"
            processContents="skip"/>
        </xs:sequence>
        <xs:attribute name="DataType" type="DTS:DtsDataTypeEnum"/>
        <xs:attribute name="DataSubType">
          <xs:simpleType>
            <xs:restriction base="xs:string">
              <xs:enumeration value="ManagedSerizlizable"/>
            </xs:restriction>
          </xs:simpleType>
        </xs:attribute>
      </xs:complexType>
    </xs:element>
  </xs:sequence>
  <xs:attributeGroup ref="DTS:BasePropertyAttributeGroup"/>
  <xs:attributeGroup ref="DTS:VariableAttributeGroup"/>
</xs:complexType>

<xs:complexType name="EventHandlersType">
  <xs:sequence>
    <xs:element name="EventHandler" type="DTS:EventHandlerType"
      minOccurs="0" maxOccurs="unbounded" form="qualified"/>
  </xs:sequence>
</xs:complexType>

<xs:complexType name="EventHandlerType">
  <xs:sequence>
    <xs:element name="PropertyExpression"
      type="DTS:PropertyExpressionElementType"
      minOccurs="0" maxOccurs="unbounded"/>
    <xs:element name="Variables" type="DTS:VariablesType" minOccurs="0"/>
    <xs:element name="LoggingOptions" type="DTS:LoggingOptionsType"/>
  </xs:sequence>
</xs:complexType>

```

```

    <xs:element name="Executables" type="DTS:ExecutablesType" minOccurs="0"/>
    <xs:element name="PrecedenceConstraints"
        type="DTS:PrecedenceConstraintsType" minOccurs="0"/>
</xs:sequence>
<xs:attributeGroup ref="DTS:BasePropertyAttributeGroup"/>
<xs:attributeGroup ref="DTS:BaseExecutablePropertyAttributeGroup"/>
<xs:attributeGroup ref="DTS:EventHandlerAttributeGroup"/>
<xs:attribute name="refId" type="xs:string" use="required"
    form="qualified"/>
</xs:complexType>

<xs:complexType name="ForEachEnumeratorType">
    <xs:sequence>
        <xs:element name="PropertyExpression"
            type="DTS:PropertyExpressionElementType"
            minOccurs="0" maxOccurs="unbounded"/>
        <xs:element name="ObjectData"
            type="DTS:ForEachEnumeratorObjectDataType"/>
    </xs:sequence>
    <xs:attributeGroup ref="DTS:BasePropertyAttributeGroup"/>
</xs:complexType>

<xs:complexType name="ForEachVariableMappingsType">
    <xs:sequence>
        <xs:element name="ForEachVariableMapping"
            type="DTS:ForEachVariableMappingType"
            minOccurs="0" maxOccurs="unbounded" form="qualified"/>
    </xs:sequence>
</xs:complexType>

<xs:complexType name="ForEachVariableMappingType" >
    <xs:sequence>
        <xs:element name="PropertyExpression"
            type="DTS:PropertyExpressionElementType"
            minOccurs="0" maxOccurs="unbounded"/>
    </xs:sequence>
    <xs:attributeGroup ref="DTS:BasePropertyAttributeGroup"/>
    <xs:attributeGroup ref="DTS:ForEachVariableMappingAttributeGroup"/>
</xs:complexType>

<!--ObjectData Executable Types-->

<xs:complexType name="ExecutableObjectDataType">
    <xs:choice minOccurs="0">
        <xs:element name="pipeline" type="DTS:pipelineObjectDataType"
            form="unqualified"/>
        <xs:element ref="ActiveXScriptTask:ActiveXScriptTaskData" />
        <xs:element name="ASDdlData" type="DTS:ASDdlDataObjectDataType"
            form="unqualified"/>
        <xs:element name="ASProcessingData" form="unqualified"
            type="DTS:ASProcessingDataObjectDataType"/>
        <xs:element ref="BulkInsertTask:BulkInsertTaskData"/>
        <xs:element name="DMQuertTaskData" form="unqualified"
            type="DTS:DMQueryTaskDataObjectDataType"/>
        <xs:element name="DataProfilingTaskData" form="unqualified"
            type="DTS:DataProfilingTaskDataObjectDataType"/>
        <xs:element ref="Exec80PackageTask:Exec80PackageTaskData"/>
        <xs:element name="ExecutePackageTask" form="unqualified"
            type="DTS:ExecutePackageTaskObjectDataType"/>
    </xs:choice>
</xs:complexType>

```

```

<xs:element name="ExecuteProcessData" form="unqualified"
  type="DTS:ExecuteProcessDataObjectDataType"/>
<xs:element ref="SQLTask:SqlTaskData"/>
<xs:element name="FileSystemData" form="unqualified"
  type="DTS:FileSystemDataObjectDataType"/>
<xs:element name="FtpData" type="DTS:FtpDataObjectDataType"
  form="unqualified"/>
<xs:element ref="MessageQueueTask:MessageQueueTaskData"/>
<xs:element name="ScriptProject" type="DTS:ScriptProjectObjectDataType"
  form="unqualified"/>
<xs:element ref="SendMailTask:SendMailTaskData"/>
<xs:element name="TransferDatabasesTaskData" form="unqualified"
  type="DTS:TransferDatabasesTaskDataObjectDataType"/>
<xs:element name="TransferErrorMessagesTaskData" form="unqualified"
  type="DTS:TransferErrorMessagesTaskDataObjectDataType"/>
<xs:element name="TransferJobsTaskData" form="unqualified"
  type="DTS:TransferJobsTaskDataObjectDataType"/>
<xs:element name="TransferLoginsTaskData" form="unqualified"
  type="DTS:TransferLoginsTaskDataObjectDataType"/>
<xs:element name="TransferStoredProceduresTaskData" form="unqualified"
  type="DTS:TransferStoredProceduresTaskDataObjectDataType"/>
<xs:element name="TransferSqlServerObjectsTaskData" form="unqualified"
  type="DTS:TransferSqlServerObjectsTaskDataObjectDataType"/>
<xs:element ref="WSTask:WebServiceTaskData"/>
<xs:element name="WMIDRTaskData" type="DTS:WMIDRTaskDataObjectDataType"
  form="unqualified"/>
<xs:element name="WMIEWTaskData" type="DTS:WMIEWTaskDataObjectDataType"
  form="unqualified"/>
<xs:element name="XMLTaskData" type="DTS:XMLTaskDataObjectDataType"
  form="unqualified"/>
<xs:element name="InnerObject" type="DTS:InnerObjectObjectDataType"
  form="unqualified"/>
</xs:choice>
</xs:complexType>

<xs:complexType name="ASDDdlDataObjectDataType">
  <xs:sequence/>
  <xs:attribute name="ConnectionName" type="xs:string"
    form="unqualified"/>
  <xs:attribute name="SourceType" form="unqualified"
    type="DTS:SourceTypeEnum"/>
  <xs:attribute name="Source" type="xs:string"
    form="unqualified"/>
</xs:complexType>

<xs:complexType name="ASProcessingDataObjectDataType">
  <xs:sequence/>
  <xs:attribute name="ConnectionName" type="xs:string"
    form="unqualified"/>
  <xs:attribute name="ProcessingCommands" type="xs:string"
    form="unqualified"/>
</xs:complexType>

<xs:complexType name="DMQueryTaskDataObjectDataType">
  <xs:sequence>
    <xs:element name="QueryString" form="unqualified"
      type="DTS:DMQueryTaskQueryStringContainerType"/>
    <xs:element name="QueryBuilderQueryString" form="unqualified"
      type="DTS:DMQueryTaskQueryStringContainerType"/>
  </xs:sequence>
</xs:complexType>

```

```

    <xs:element name="QueryBuilderSpecification" form="unqualified"
      type="DTS:DMQueryBuilderSpecificationType"/>
  </xs:sequence>
  <xs:attribute name="InputConnection" type="xs:string"
    form="unqualified"/>
  <xs:attribute name="OutputConnection" type="xs:string"
    form="unqualified"/>
  <xs:attribute name="ModelStructureName" type="xs:string"
    form="unqualified"/>
  <xs:attribute name="ModelName" type="xs:string" form="unqualified"/>
  <xs:attribute name="OverwriteOutputTable" form="unqualified">
    <xs:simpleType>
      <xs:restriction base="xs:string">
        <xs:enumeration value="True"/>
        <xs:enumeration value="False"/>
      </xs:restriction>
    </xs:simpleType>
  </xs:attribute>
  <xs:attribute name="OutputTableName" type="xs:string"
    form="unqualified"/>
</xs:complexType>

<xs:complexType name="DMQueryTaskQueryStringContainerType">
  <xs:simpleContent>
    <xs:extension base="xs:string">
      <xs:attribute name="Sensitive" type="xs:boolean"
        form="unqualified"/>
      <xs:attribute name="Encrypted" type="xs:boolean"
        form="unqualified"/>
    </xs:extension>
  </xs:simpleContent>
</xs:complexType>

<xs:complexType name="DMQueryBuilderSpecificationType">
  <xs:sequence>
    <xs:any minOccurs="0" maxOccurs="unbounded"
      namespace="##any" processContents="lax"/>
  </xs:sequence>
  <xs:attribute name="Sensitive" type="xs:boolean"
    form="unqualified"/>
  <xs:attribute name="Encrypted" type="xs:boolean"
    form="unqualified"/>
</xs:complexType>

<xs:complexType name="DataProfilingTaskDataObjectDataType">
  <xs:sequence>
    <xs:element name="ProfileInput" type="xs:string"
      form="unqualified"/>
  </xs:sequence>
  <xs:attribute name="DestinationType" form="unqualified"
    type="DTS:DestinationTypeEnum"
    use="optional" default="FileConnection"/>
  <xs:attribute name="Destination" type="xs:string"
    form="unqualified" use="optional" default=""/>
  <xs:attribute name="OverwriteDestination" form="unqualified"
    use="optional" default="False">
    <xs:simpleType>
      <xs:restriction base="xs:string">
        <xs:enumeration value="True"/>
      </xs:restriction>
    </xs:simpleType>
  </xs:attribute>
</xs:complexType>

```

```

        <xs:enumeration value="False"/>
    </xs:restriction>
</xs:simpleType>
</xs:attribute>
</xs:complexType>

<xs:simpleType name="DestinationTypeEnum">
    <xs:restriction base="xs:string">
        <xs:enumeration value="FileConnection"/>
        <xs:enumeration value="Variable"/>
    </xs:restriction>
</xs:simpleType>

<xs:complexType name="ExecutePackageTaskObjectDataType">
    <xs:sequence>
        <xs:element name="ExecuteOutOfProcess" form="unqualified">
            <xs:simpleType>
                <xs:restriction base="xs:string">
                    <xs:enumeration value="True"/>
                    <xs:enumeration value="False"/>
                </xs:restriction>
            </xs:simpleType>
        </xs:element>
        <xs:element name="PackageName" type="xs:string"
            form="unqualified"/>
        <xs:element name="UseProjectReference" type="DTS:BooleanStringCap"
            minOccurs="0" form="unqualified"/>
        <xs:element name="PackagePassword" type="DTS>PasswordElementType"
            form="unqualified"/>
        <xs:element name="PackageID" type="DTS:uuid" form="unqualified"/>
        <xs:element name="VersionID" type="DTS:uuid" form="unqualified"/>
        <xs:element name="Connection" type="xs:string" form="unqualified"/>
    </xs:sequence>
</xs:complexType>

<xs:complexType name="ExecuteProcessDataObjectDataType">
    <xs:sequence>
</xs:sequence>
    <xs:attribute name="Executable" type="xs:string" form="unqualified"
        use="optional" default=""/>
    <xs:attribute name="RequireFullFileName" form="unqualified"
        use="optional" type="DTS:BooleanStringCap"
        default="True"/>
    <xs:attribute name="Arguments" type="xs:string" form="unqualified"
        use="optional" default=""/>
    <xs:attribute name="WorkingDirectory" type="xs:string"
        use="optional" default="" form="unqualified"/>
    <xs:attribute name="TimeOut" type="xs:string" form="unqualified"
        use="optional" default="0"/>
    <xs:attribute name="FailTaskIfReturnCodeIsNotSuccessValue"
        use="optional" default="True" form="unqualified">
        <xs:simpleType>
            <xs:restriction base="xs:string">
                <xs:enumeration value="True"/>
                <xs:enumeration value="False"/>
            </xs:restriction>
        </xs:simpleType>
    </xs:attribute>
    <xs:attribute name="SuccessValue" type="xs:string" form="unqualified">

```

```

        use="optional" default="0"/>
<xs:attribute name="TerminateAfterTimeout" form="unqualified"
    use="optional" default="True">
    <xs:simpleType>
        <xs:restriction base="xs:string">
            <xs:enumeration value="True"/>
            <xs:enumeration value="False"/>
        </xs:restriction>
    </xs:simpleType>
</xs:attribute>
<xs:attribute name="StandardInputVariable" type="xs:string"
    use="optional" default="" form="unqualified"/>
<xs:attribute name="StandardOutputVariable" type="xs:string"
    use="optional" default="" form="unqualified"/>
<xs:attribute name="StandardErrorVariable" type="xs:string"
    use="optional" default="" form="unqualified"/>
<xs:attribute name="WindowStyle" form="unqualified"
    type="DTS:WindowStyleEnum"
    use="optional" default="Normal"/>
</xs:complexType>

<xs:simpleType name="WindowStyleEnum">
    <xs:restriction base="xs:string">
        <xs:enumeration value="Hidden"/>
        <xs:enumeration value="Maximized"/>
        <xs:enumeration value="Minimized"/>
        <xs:enumeration value="Normal"/>
    </xs:restriction>
</xs:simpleType>

<xs:complexType name="FileSystemDataObjectDataType">
    <xs:sequence/>
    <xs:attribute name="TaskOperationType" form="unqualified"
        type="DTS:FileSystemTaskOperationTypeEnum"
        use="optional" default="CopyFile"/>
    <xs:attribute name="OperationName" form="unqualified"
        type="xs:string" use="optional" default=""/>
    <xs:attribute name="TaskOverwriteDestFile" form="unqualified"
        use="optional" default="False">
        <xs:simpleType>
            <xs:restriction base="xs:string">
                <xs:enumeration value="False"/>
                <xs:enumeration value="True"/>
            </xs:restriction>
        </xs:simpleType>
    </xs:attribute>
    <xs:attribute name="TaskSourcePath" form="unqualified"
        type="xs:string" use="optional" default=""/>
    <xs:attribute name="TaskIsSourceVariable" form="unqualified"
        use="optional" default="False">
        <xs:simpleType>
            <xs:restriction base="xs:string">
                <xs:enumeration value="False"/>
                <xs:enumeration value="True"/>
            </xs:restriction>
        </xs:simpleType>
    </xs:attribute>
    <xs:attribute name="TaskDestinationPath" form="unqualified"
        type="xs:string" use="optional" default=""/>

```

```

<xs:attribute name="TaskIsDestinationVariable" form="unqualified">
  <xs:simpleType>
    <xs:restriction base="xs:string">
      <xs:enumeration value="False"/>
      <xs:enumeration value="True"/>
    </xs:restriction>
  </xs:simpleType>
</xs:attribute>
<xs:attribute name="TaskFileAttributes" form="unqualified"
  type="DTS:FileSystemTaskFileAttributesEnum"
  use="optional" default="Normal"/>
</xs:complexType>

<xs:complexType name="FtpDataObjectDataType">
  <xs:sequence>
  </xs:sequence>
  <xs:attribute name="ConnectionName" type="xs:string"
    use="optional" default="" form="unqualified"/>
  <xs:attribute name="StopOnFailure" form="unqualified">
    <xs:simpleType>
      <xs:restriction base="xs:string">
        <xs:enumeration value="False"/>
        <xs:enumeration value="True"/>
      </xs:restriction>
    </xs:simpleType>
  </xs:attribute>
  <xs:attribute name="TaskOperationType"
    type="DTS:FtpDataTaskOperationTypeEnum"
    use="optional" default="Send" form="unqualified"/>
  <xs:attribute name="TaskOperationName" type="xs:string"
    use="optional" default="" form="unqualified"/>
  <xs:attribute name="TaskIsLocalPathVar" form="unqualified"
    use="optional" default="False">
    <xs:simpleType>
      <xs:restriction base="xs:string">
        <xs:enumeration value="False"/>
        <xs:enumeration value="True"/>
      </xs:restriction>
    </xs:simpleType>
  </xs:attribute>
  <xs:attribute name="TaskLocalPath" type="xs:string"
    use="optional" default="" form="unqualified"/>
  <xs:attribute name="TaskIsRemotePathVar" form="unqualified"
    use="optional" default="False">
    <xs:simpleType>
      <xs:restriction base="xs:string">
        <xs:enumeration value="False"/>
        <xs:enumeration value="True"/>
      </xs:restriction>
    </xs:simpleType>
  </xs:attribute>
  <xs:attribute name="TaskRemotePath" type="xs:string"
    use="optional" default="" form="unqualified"/>
  <xs:attribute name="TaskOverwriteDest" form="unqualified"
    use="optional" default="False">
    <xs:simpleType>
      <xs:restriction base="xs:string">
        <xs:enumeration value="False"/>
        <xs:enumeration value="True"/>
      </xs:restriction>
    </xs:simpleType>
  </xs:attribute>

```



```

        </xs:restriction>
      </xs:simpleType>
    </xs:attribute>
    <xs:attribute name="TaskTransferAscii" form="unqualified"
      use="optional" default="False">
      <xs:simpleType>
        <xs:restriction base="xs:string">
          <xs:enumeration value="False"/>
          <xs:enumeration value="True"/>
        </xs:restriction>
      </xs:simpleType>
    </xs:attribute>
  </xs:complexType>

  <xs:simpleType name="FtpDataTaskOperationTypeEnum">
    <xs:restriction base="xs:string">
      <xs:enumeration value="DeleteLocal"/>
      <xs:enumeration value="DeleteRemote"/>
      <xs:enumeration value="MakeDirLocal"/>
      <xs:enumeration value="MakeDirRemote"/>
      <xs:enumeration value="Receive"/>
      <xs:enumeration value="RemoveDirLocal"/>
      <xs:enumeration value="RemoveDirRemote"/>
      <xs:enumeration value="Send"/>
    </xs:restriction>
  </xs:simpleType>

  <xs:complexType name="ScriptProjectObjectDataType">
    <xs:sequence>
      <xs:element name="ProjectItem"
        type="DTS:ScriptProjectProjectItemType"
        minOccurs="0" maxOccurs="unbounded"
        form="unqualified"/>
      <xs:element name="BinaryItem"
        type="DTS:ScriptProjectBinaryItemType"
        minOccurs="0" form="unqualified"/>
      <xs:element name="Breakpoint"
        type="DTS:ScriptProjectBreakpointType"
        minOccurs="0" maxOccurs="unbounded"
        form="unqualified"/>
    </xs:sequence>
    <xs:attribute name="Name" type="xs:string" form="unqualified"/>
    <xs:attribute name="VSTAMajorVersion" type="xs:int"
      form="unqualified"/>
    <xs:attribute name="VSTAMinorVersion" type="xs:int"
      form="unqualified"/>
    <xs:attribute name="Language" type="DTS:ScriptProjectLanguageEnum"
      form="unqualified"/>
    <xs:attribute name="EntryPoint" type="xs:string"
      form="unqualified"/>
    <xs:attribute name="ReadOnlyVariables" type="xs:string"
      form="unqualified"/>
    <xs:attribute name="ReadWriteVariables" type="xs:string"
      form="unqualified"/>
  </xs:complexType>

  <xs:complexType name="ScriptProjectProjectItemType">
    <xs:simpleContent>
      <xs:extension base="xs:string">

```

```

        <xs:attribute name="Name" type="xs:string"
                    form="unqualified"/>
    </xs:extension>
    <xs:attribute name="Encoding" type="xs:string"
                form="unqualified"/>
</xs:simpleContent>
</xs:complexType>

<xs:complexType name="ScriptProjectBinaryItemType">
  <xs:simpleContent>
    <xs:extension base="xs:base64Binary">
      <xs:attribute name="Name" type="xs:string"
                    form="unqualified"/>
    </xs:extension>
  </xs:simpleContent>
</xs:complexType>

<xs:complexType name="ScriptProjectBreakpointType">
  <xs:sequence/>
  <xs:attribute name="Name" type="xs:string" form="unqualified"/>
  <xs:attribute name="Enabled" type="xs:string"
                form="unqualified"/>
  <xs:attribute name="Function" type="xs:string"
                form="unqualified"/>
  <xs:attribute name="File" type="xs:string" form="unqualified"/>
  <xs:attribute name="Line" type="xs:int" form="unqualified"/>
  <xs:attribute name="Column" type="xs:int" form="unqualified"/>
  <xs:attribute name="Condition" type="xs:string"
                form="unqualified"/>
  <xs:attribute name="ConditionType"
                type="DTS:ScriptProjectConditionTypeEnum"
                form="unqualified"/>
  <xs:attribute name="Language" type="xs:string"
                form="unqualified"/>
  <xs:attribute name="HitCount" type="xs:int" form="unqualified"/>
  <xs:attribute name="HitCountType" form="unqualified"
                type="DTS:ScriptProjectHitCountTypeEnum"/>
</xs:complexType>

<xs:simpleType name="ScriptProjectLanguageEnum">
  <xs:restriction base="xs:string">
    <xs:enumeration value="CSharp"/>
    <xs:enumeration value="VisualBasic"/>
  </xs:restriction>
</xs:simpleType>

<xs:simpleType name="ScriptProjectHitCountTypeEnum">
  <xs:restriction base="xs:int">
    <xs:minInclusive value="1"/>
    <xs:maxInclusive value="4"/>
  </xs:restriction>
</xs:simpleType>

<xs:simpleType name="ScriptProjectConditionTypeEnum">
  <xs:restriction base="xs:int">
    <xs:minInclusive value="1"/>
    <xs:maxInclusive value="2"/>
  </xs:restriction>
</xs:simpleType>

```

```

<xs:complexType name="TransferDatabasesTaskDataObjectDataType">
  <xs:sequence/>
  <xs:attribute name="SrcConn" type="xs:string" use="optional" default=""
    form="unqualified"/>
  <xs:attribute name="DestConn" type="xs:string" use="optional"
    default="" form="unqualified"/>
  <xs:attribute name="Action" type="DTS:TransferDatabaseTaskActionEnum"
    use="optional" default="0" form="unqualified"/>
  <xs:attribute name="Method" type="DTS:TransferDatabaseTaskMethodEnum"
    use="optional" default="0" form="unqualified"/>
  <xs:attribute name="SrcDBName" type="xs:string" use="optional"
    default="" form="unqualified"/>
  <xs:attribute name="ReattachSrcDB" type="xs:boolean"
    use="optional" default="false" form="unqualified"/>
  <xs:attribute name="SrcDBFiles" type="xs:string"
    use="optional" default="" form="unqualified"/>
  <xs:attribute name="DestDBName" type="xs:string"
    use="optional" default="" form="unqualified"/>
  <xs:attribute name="DestDBFiles" type="xs:string"
    use="optional" default="" form="unqualified"/>
  <xs:attribute name="DestOverwrite" type="xs:boolean"
    use="optional" default="false" form="unqualified"/>
</xs:complexType>

<xs:simpleType name="TransferDatabaseTaskActionEnum">
  <xs:restriction base="xs:int">
    <xs:minInclusive value="0"/>
    <xs:maxInclusive value="1"/>
  </xs:restriction>
</xs:simpleType>

<xs:simpleType name="TransferDatabaseTaskMethodEnum">
  <xs:restriction base="xs:int">
    <xs:minInclusive value="0"/>
    <xs:maxInclusive value="1"/>
  </xs:restriction>
</xs:simpleType>

<xs:complexType name="TransferErrorMessagesTaskDataObjectDataType">
  <xs:sequence/>
  <xs:attribute name="TransferAllErrorMessages" type="xs:boolean"
    use="optional" default="false" form="unqualified"/>
  <xs:attribute name="ErrorMessagesList" type="xs:string"
    use="optional" default="" form="unqualified"/>
  <xs:attribute name="ErrorMessageLanguagesList" type="xs:string"
    use="optional" default="" form="unqualified"/>
  <xs:attribute name="IfObjectExists"
    type="DTS:IfObjectExistsEnum"
    use="optional" default="FailTask" form="unqualified"/>
  <xs:attribute name="SourceConnection" type="xs:string"
    use="optional" default="" form="unqualified"/>
  <xs:attribute name="DestinationConnection" type="xs:string"
    use="optional" default="" form="unqualified"/>
</xs:complexType>

<xs:simpleType name="IfObjectExistsEnum">
  <xs:restriction base="xs:string">
    <xs:enumeration value="FailTask"/>
  </xs:restriction>
</xs:simpleType>

```

```

    <xs:enumeration value="Overwrite"/>
    <xs:enumeration value="Skip"/>
  </xs:restriction>
</xs:simpleType>

<xs:complexType name="TransferJobsTaskDataObjectDataType">
  <xs:sequence/>
  <xs:attribute name="TransferAllJobs" type="xs:boolean"
    use="optional" default="false" form="unqualified"/>
  <xs:attribute name="JobsList" type="xs:string"
    use="optional" default="" form="unqualified"/>
  <xs:attribute name="IfObjectExists" type="DTS:IfObjectExistsEnum"
    use="optional" default="FailTask" form="unqualified"/>
  <xs:attribute name="EnableJobsAtDestination" type="xs:boolean"
    use="optional" default="false" form="unqualified"/>
  <xs:attribute name="SourceConnection" type="xs:string"
    use="optional" default="" form="unqualified"/>
  <xs:attribute name="DestinationConnection" type="xs:string"
    use="optional" default="" form="unqualified"/>
</xs:complexType>

<xs:complexType name="TransferLoginsTaskDataObjectDataType">
  <xs:sequence/>
  <xs:attribute name="LoginsToTransfer"
    type="DTS:TransferLoginsTaskLoginsToTransferEnum"
    use="optional" default="SelectedLogins"
    form="unqualified"/>
  <xs:attribute name="CopySids" type="xs:boolean" form="unqualified"
    use="optional" default="false"/>
  <xs:attribute name="LoginList" type="xs:string" form="unqualified"
    use="optional" default="" />
  <xs:attribute name="IfObjectExists" type="DTS:IfObjectExistsEnum"
    use="optional" default="FailTask" form="unqualified"/>
  <xs:attribute name="SourceConnection" type="xs:string"
    use="optional" default="" form="unqualified"/>
  <xs:attribute name="DestinationConnection" type="xs:string"
    use="optional" default="" form="unqualified"/>
  <xs:attribute name="DatabasesList" type="xs:string"
    use="optional" default="" form="unqualified"/>
</xs:complexType>

<xs:simpleType name="TransferLoginsTaskLoginsToTransferEnum">
  <xs:restriction base="xs:string">
    <xs:enumeration value="SelectedLogins"/>
    <xs:enumeration value="AllLoginsFromSelectedDatabases"/>
    <xs:enumeration value="AllLogins"/>
  </xs:restriction>
</xs:simpleType>

<xs:complexType name="TransferStoredProceduresTaskDataObjectDataType">
  <xs:sequence/>
  <xs:attribute name="TransferAllStoredProcedures"
    type="xs:boolean" use="optional" default="false"
    form="unqualified"/>
  <xs:attribute name="StoredProceduresList" type="xs:string"
    use="optional" default="" form="unqualified"/>
  <xs:attribute name="IfObjectExists" type="DTS:IfObjectExistsEnum"
    use="optional" default="FailTask" form="unqualified"/>
  <xs:attribute name="SourceConnection" type="xs:string"

```

```

        use="optional" default="" form="unqualified"/>
<xs:attribute name="m_DestinationConnectionID"
        use="optional" default="" type="xs:string"
        form="unqualified"/>
</xs:complexType>

<xs:complexType name="TransferSqlServerObjectsTaskDataObjectDataType">
  <xs:sequence/>
  <xs:attribute name="SourceConnection" type="xs:string"
    use="optional" default="" form="unqualified"/>
  <xs:attribute name="DestinationConnection" type="xs:string"
    use="optional" default="" form="unqualified"/>
  <xs:attribute name="SourceDatabase" type="xs:string"
    use="optional" default="" form="unqualified"/>
  <xs:attribute name="DestinationDatabase" type="xs:string"
    use="optional" default="" form="unqualified"/>
  <xs:attribute name="CopyAllObjects" type="xs:boolean"
    use="optional" default="false" form="unqualified"/>
  <xs:attribute name="CopyAllRules" type="xs:boolean"
    use="optional" default="false" form="unqualified"/>
  <xs:attribute name="CopyAllTables" type="xs:boolean"
    use="optional" default="false" form="unqualified"/>
  <xs:attribute name="CopyAllViews" type="xs:boolean"
    use="optional" default="false" form="unqualified"/>
  <xs:attribute name="CopyAllStoredProcedures"
    type="xs:boolean" use="optional" default="false"
    form="unqualified"/>
  <xs:attribute name="CopyAllUserDefinedFunctions"
    type="xs:boolean" use="optional" default="false"
    form="unqualified"/>
  <xs:attribute name="CopyAllDefaults" type="xs:string"
    use="optional" default="false" form="unqualified"/>
  <xs:attribute name="CopyAllUserDefinedDataTypes"
    use="optional" default="false" type="xs:boolean"
    form="unqualified"/>
  <xs:attribute name="CopyAllPartitionFunctions" type="xs:boolean"
    use="optional" default="false" form="unqualified"/>
  <xs:attribute name="CopyAllPartitionSchemes" type="xs:boolean"
    use="optional" default="false" form="unqualified"/>
  <xs:attribute name="CopyAllSchemas" type="xs:boolean"
    use="optional" default="false" form="unqualified"/>
  <xs:attribute name="CopyAllSqlAssemblies" type="xs:boolean"
    use="optional" default="false" form="unqualified"/>
  <xs:attribute name="CopyAllUserDefinedAggregates"
    use="optional" default="false" type="xs:boolean"
    form="unqualified"/>
  <xs:attribute name="CopyAllUserDefinedTypes" type="xs:boolean"
    use="optional" default="false" form="unqualified"/>
  <xs:attribute name="CopyAllXmlSchemaCollections" type="xs:boolean"
    use="optional" default="false" form="unqualified"/>
  <xs:attribute name="LoginsList" type="xs:string"
    use="optional" default="" form="unqualified"/>
  <xs:attribute name="UsersList" type="xs:string"
    use="optional" default="" form="unqualified"/>
  <xs:attribute name="RulesList" type="xs:string"
    use="optional" default="" form="unqualified"/>
  <xs:attribute name="TablesList" type="xs:string"
    use="optional" default="" form="unqualified"/>
  <xs:attribute name="ViewsList" type="xs:string"

```

```

        use="optional" default="" form="unqualified"/>
<xs:attribute name="StoredProceduresList"
    type="xs:string" use="optional" default=""
    form="unqualified"/>
<xs:attribute name="UserDefinedFunctionsList"
    type="xs:string" use="optional" default=""
    form="unqualified"/>
<xs:attribute name="DefaultsList" type="xs:string"
    use="optional" default="" form="unqualified"/>
<xs:attribute name="UserDefinedDataTypesList"
    type="xs:string" use="optional" default=""
    form="unqualified"/>
<xs:attribute name="PartitionFunctionsList" type="xs:string"
    use="optional" default="" form="unqualified"/>
<xs:attribute name="PartitionSchemesList" type="xs:string"
    use="optional" default="" form="unqualified"/>
<xs:attribute name="SchemasList" type="xs:string"
    use="optional" default="" form="unqualified"/>
<xs:attribute name="SqlAssembliesList" type="xs:string"
    use="optional" default="" form="unqualified"/>
<xs:attribute name="UserDefinedAggregatesList"
    type="xs:string" use="optional" default=""
    form="unqualified"/>
<xs:attribute name="UserDefinedTypesList" type="xs:string"
    use="optional" default="" form="unqualified"/>
<xs:attribute name="XmlSchemaCollectionsList" type="xs:string"
    use="optional" default="" form="unqualified"/>
<xs:attribute name="DropObjectsFirst" type="xs:boolean"
    use="optional" default="false" form="unqualified"/>
<xs:attribute name="IncludeDependentObjects"
    type="xs:boolean" use="optional" default="false"
    form="unqualified"/>
<xs:attribute name="IncludeExtendedProperties" type="xs:boolean"
    use="optional" default="false" form="unqualified"/>
<xs:attribute name="CopyData" type="xs:boolean"
    use="optional" default="false" form="unqualified"/>
<xs:attribute name="ExistingData"
    type="DTS:TransferSqlServerObjectsTaskExistingDataEnum"
    use="optional" default="Replace" form="unqualified"/>
<xs:attribute name="CopySchema" type="xs:boolean"
    use="optional" default="true" form="unqualified"/>
<xs:attribute name="UseCollation" type="xs:boolean"
    use="optional" default="false" form="unqualified"/>
<xs:attribute name="CopyDatabaseUsers" type="xs:boolean"
    use="optional" default="false" form="unqualified"/>
<xs:attribute name="CopyDatabaseRoles" type="xs:boolean"
    use="optional" default="false" form="unqualified"/>
<xs:attribute name="CopySqlServerLogins" type="xs:boolean"
    use="optional" default="false" form="unqualified"/>
<xs:attribute name="CopyObjectLevelPermissions" type="xs:boolean"
    use="optional" default="false" form="unqualified"/>
<xs:attribute name="CopyIndexes" type="xs:boolean"
    use="optional" default="false" form="unqualified"/>
<xs:attribute name="CopyTriggers" type="xs:boolean"
    use="optional" default="false" form="unqualified"/>
<xs:attribute name="CopyFullTextIndexes" type="xs:boolean"
    use="optional" default="false" form="unqualified"/>
<xs:attribute name="CopyPrimaryKeys" type="xs:boolean"
    use="optional" default="false" form="unqualified"/>

```

```

<xs:attribute name="CopyForeignKeys" type="xs:boolean"
  use="optional" default="false" form="unqualified"/>
<xs:attribute name="GenerateScriptsInUnicode" type="xs:boolean"
  use="optional" default="false" form="unqualified"/>
<xs:attribute name="SourceTranslateChar" type="xs:boolean"
  use="optional" default="false" form="unqualified"/>
<xs:attribute name="DestinationTranslateChar" type="xs:boolean"
  use="optional" default="false" form="unqualified"/>
<xs:attribute name="CopyAllDRIObjects" type="xs:boolean"
  use="optional" default="false" form="unqualified"/>
</xs:complexType>

<xs:simpleType name="ListStringType">
  <xs:restriction base="xs:string">
    <xs:pattern value="[0-9]+,?([0-9]+,\.+){0,}" />
  </xs:restriction>
</xs:simpleType>

<xs:simpleType name="TransferSqlServerObjectsTaskExistingDataEnum">
  <xs:restriction base="xs:string">
    <xs:enumeration value="Replace" />
    <xs:enumeration value="Append" />
  </xs:restriction>
</xs:simpleType>

<xs:complexType name="WMIDRTaskDataObjectDataType">
  <xs:sequence/>
  <xs:attribute name="WQLQuerySourceType" type="DTS:SourceTypeEnum"
    use="optional" default="DirectInput" form="unqualified"/>
  <xs:attribute name="WQLQuerySource" type="xs:string"
    use="optional" default="" form="unqualified"/>
  <xs:attribute name="DestinationType"
    type="DTS:DestinationTypeEnum" form="unqualified"
    use="optional" default="FileConnection"/>
  <xs:attribute name="Destination" type="xs:string"
    use="optional" default="" form="unqualified"/>
  <xs:attribute name="OverwriteDestination"
    type="DTS:WMITaskDataOverwriteDestinationEnum"
    use="optional" default="KeepOriginal" form="unqualified"/>
  <xs:attribute name="OutputType"
    type="DTS:WMITaskDataOutputTypeEnum"
    use="optional" default="DataTable" form="unqualified"/>
  <xs:attribute name="WMIConnectionName" type="xs:string"
    use="optional" default="" form="unqualified"/>
</xs:complexType>

<xs:simpleType name="WMITaskDataOverwriteDestinationEnum">
  <xs:restriction base="xs:string">
    <xs:enumeration value="KeepOriginal" />
    <xs:enumeration value="AppendToDestination" />
    <xs:enumeration value="OverwriteDestination" />
  </xs:restriction>
</xs:simpleType>

<xs:simpleType name="WMITaskDataOutputTypeEnum">
  <xs:restriction base="xs:string">
    <xs:enumeration value="DataTable" />
    <xs:enumeration value="PropertyNameAndValue" />
    <xs:enumeration value="PropertyValue" />
  </xs:restriction>
</xs:simpleType>

```

```

    </xs:restriction>
</xs:simpleType>

<xs:complexType name="WMIEWTaskDataObjectDataType">
  <xs:sequence/>
  <xs:attribute name="WMIConnectionName" type="xs:string"
    use="optional" default="" form="unqualified"/>
  <xs:attribute name="WQLQuerySourceType" type="DTS:SourceTypeEnum"
    use="optional" default="DirectInput" form="unqualified"/>
  <xs:attribute name="WQLQuerySource" type="xs:string"
    use="optional" default="" form="unqualified"/>
  <xs:attribute name="ActionAtEvent"
    type="DTS:WMIEWTaskDataActionAtEventEnum"
    use="optional" default="LogTheEventAndFireDTSEvent"
    form="unqualified"/>
  <xs:attribute name="AfterEvent"
    type="DTS:WMIEWTaskDataAfterEventEnum"
    use="optional" default="ReturnWithSuccess"
    form="unqualified"/>
  <xs:attribute name="ActionAtTimeout"
    type="DTS:WMIEWTaskDataActionAtTimeoutEnum"
    use="optional" default="LogTimeoutAndFireDTSEvent"
    form="unqualified"/>
  <xs:attribute name="AfterTimeout"
    type="DTS:WMIEWTaskDataAfterEventEnum"
    use="optional" default="ReturnWithFailure"
    form="unqualified"/>
  <xs:attribute name="NumberOfEvents" type="xs:int"
    use="optional" default="1" form="unqualified"/>
  <xs:attribute name="Timeout" type="xs:int" form="unqualified"
    use="optional" default="0"/>
</xs:complexType>

<xs:simpleType name="WMIEWTaskDataActionAtEventEnum">
  <xs:restriction base="xs:string">
    <xs:enumeration value="LogTheEventAndFireDTSEvent"/>
    <xs:enumeration value="LogTheEvent"/>
  </xs:restriction>
</xs:simpleType>

<xs:simpleType name="WMIEWTaskDataAfterEventEnum">
  <xs:restriction base="xs:string">
    <xs:enumeration value="WatchfortheEventAgain"/>
    <xs:enumeration value="ReturnWithSuccess"/>
    <xs:enumeration value="ReturnWithFailure"/>
  </xs:restriction>
</xs:simpleType>

<xs:simpleType name="WMIEWTaskDataActionAtTimeoutEnum">
  <xs:restriction base="xs:string">
    <xs:enumeration value="LogTimeoutAndFireDTSEvent"/>
    <xs:enumeration value="LogTimeout"/>
  </xs:restriction>
</xs:simpleType>

<xs:complexType name="XMLTaskDataObjectDataType">
  <xs:sequence>
</xs:sequence>

```



```

<xs:attribute name="OperationType" form="unqualified"
  type="DTS:XMLTaskOperationTypeEnum"
  use="optional" default="Diff"/>
<xs:attribute name="SourceType" type="DTS:SourceTypeEnum"
  use="optional" default="FileConnection"
  form="unqualified"/>
<xs:attribute name="Source" type="xs:string" form="unqualified"
  use="optional" default="" />
<xs:attribute name="SecondOperandType" type="DTS:SourceTypeEnum"
  use="optional" default="DirectInput" form="unqualified"/>
<xs:attribute name="SecondOperand" type="xs:string"
  use="optional" default="" form="unqualified"/>
<xs:attribute name="SaveOperationResult" form="unqualified"
  use="optional" default="False">
  <xs:simpleType>
    <xs:restriction base="xs:string">
      <xs:enumeration value="True"/>
      <xs:enumeration value="False"/>
    </xs:restriction>
  </xs:simpleType>
</xs:attribute>
<xs:attribute name="DestinationType"
  type="DTS:DestinationTypeEnum" form="unqualified"
  use="optional" default="FileConnection" />
<xs:attribute name="Destination" type="xs:string"
  use="optional" default="" form="unqualified"/>
<xs:attribute name="OverwriteDestination" form="unqualified"
  use="optional" default="False">
  <xs:simpleType>
    <xs:restriction base="xs:string">
      <xs:enumeration value="True"/>
      <xs:enumeration value="False"/>
    </xs:restriction>
  </xs:simpleType>
</xs:attribute>
<xs:attribute name="FailOpOnValidationFail" form="unqualified"
  use="optional" default="False">
  <xs:simpleType>
    <xs:restriction base="xs:string">
      <xs:enumeration value="True"/>
      <xs:enumeration value="False"/>
    </xs:restriction>
  </xs:simpleType>
</xs:attribute>
<xs:attribute name="FailOpOnDifference" form="unqualified"
  use="optional" default="False">
  <xs:simpleType>
    <xs:restriction base="xs:string">
      <xs:enumeration value="True"/>
      <xs:enumeration value="False"/>
    </xs:restriction>
  </xs:simpleType>
</xs:attribute>
<xs:attribute name="SaveDiffGram" form="unqualified"
  use="optional" default="False">
  <xs:simpleType>
    <xs:restriction base="xs:string">
      <xs:enumeration value="True"/>
      <xs:enumeration value="False"/>
    </xs:restriction>
  </xs:simpleType>

```

```

        </xs:restriction>
    </xs:simpleType>
</xs:attribute>
<xs:attribute name="DiffGramDestinationType" form="unqualified"
    type="DTS:DestinationTypeEnum" use="optional"
    default="FileConnection"/>
<xs:attribute name="DiffGramDestination" form="unqualified"
    type="xs:string" use="optional" default=""/>
<xs:attribute name="DiffOptions" type="DTS:XMLTaskDiffOptionsType"
    use="optional" default="20" form="unqualified"/>
<xs:attribute name="DiffAlgorithm" form="unqualified"
    type="DTS:XMLTaskDiffAlgorithmEnum"
    use="optional" default="Fast"/>
<xs:attribute name="XPathStringSourceType"
    type="DTS:SourceTypeEnum" form="unqualified"
    use="optional" default="DirectInput"/>
<xs:attribute name="XPathStringSource" type="xs:string"
    use="optional" default="" form="unqualified"/>
<xs:attribute name="XPathOperation" form="unqualified"
    type="DTS:XMLTaskXPathOperationEnum"
    use="optional" default="Evaluation" />
<xs:attribute name="PutResultInOneNode" form="unqualified"
    use="optional" default="False">
    <xs:simpleType>
        <xs:restriction base="xs:string">
            <xs:enumeration value="True"/>
            <xs:enumeration value="False"/>
        </xs:restriction>
    </xs:simpleType>
</xs:attribute>
<xs:attribute name="ValidationType"
    type="DTS:XMLTaskValidationTypeEnum"
    use="optional" default="XSD" form="unqualified"/>
</xs:complexType>

<xs:simpleType name="XMLTaskOperationTypeEnum">
    <xs:restriction base="xs:string">
        <xs:enumeration value="Diff"/>
        <xs:enumeration value="Validate"/>
        <xs:enumeration value="Merge"/>
        <xs:enumeration value="XSLT"/>
        <xs:enumeration value="XPATH"/>
        <xs:enumeration value="Patch"/>
    </xs:restriction>
</xs:simpleType>

<xs:simpleType name="XMLTaskDiffOptionsType">
    <xs:restriction base="xs:int">
        <xs:minInclusive value="0"/>
        <xs:maxInclusive value="255"/>
    </xs:restriction>
</xs:simpleType>

<xs:simpleType name="XMLTaskDiffAlgorithmEnum">
    <xs:restriction base="xs:string">
        <xs:enumeration value="Auto"/>
        <xs:enumeration value="Fast"/>
        <xs:enumeration value="Precise"/>
    </xs:restriction>

```

```

</xs:simpleType>

<xs:simpleType name="XMLTaskXPathOperationEnum">
  <xs:restriction base="xs:string">
    <xs:enumeration value="Evaluation"/>
    <xs:enumeration value="NodeList"/>
    <xs:enumeration value="Values"/>
  </xs:restriction>
</xs:simpleType>

<xs:simpleType name="XMLTaskValidationTypeEnum">
  <xs:restriction base="xs:string">
    <xs:enumeration value="DTD"/>
    <xs:enumeration value="XSD"/>
  </xs:restriction>
</xs:simpleType>

<xs:complexType name="InnerObjectObjectDataType">
  <xs:sequence>
    <xs:any minOccurs="0" maxOccurs="unbounded"
      namespace="##any" processContents="skip"/>
  </xs:sequence>
</xs:complexType>

<!--Support Types Contained by ObjectData for Executables-->

<!--pipelineObjectDataType-->

<xs:complexType name="pipelineObjectDataType">
  <xs:sequence>
    <xs:sequence>
      <xs:element name="components" type="DTS:PipelineComponentsType"
        form="unqualified"/>
      <xs:element name="paths" type="DTS:PipelinePathsType"
        minOccurs="0" form="unqualified"/>
    </xs:sequence>
  </xs:sequence>
  <xs:attribute name="id" type="xs:int" form="unqualified"
    use="required"/>
  <xs:attribute name="name" type="xs:string" form="unqualified"
    use="optional" default=""/>
  <xs:attribute name="version" type="xs:int" form="unqualified"
    use="optional" fixed="1"/>
  <xs:attribute name="description" type="xs:string"
    use="optional" default="" form="unqualified"/>
  <xs:attribute name="defaultBufferMaxRows" type="xs:int"
    use="optional" default="10000" form="unqualified"/>
  <xs:attribute name="engineThreads" type="xs:int"
    use="optional" default="10" form="unqualified"/>
  <xs:attribute name="defaultBufferSize" type="xs:int"
    use="optional" default="10485760" form="unqualified"/>
  <xs:attribute name="BLOBTempStoragePath" type="xs:string"
    use="optional" default="" form="unqualified"/>
  <xs:attribute name="bufferTempStoragePath" type="xs:string"
    use="optional" default="" form="unqualified"/>
  <xs:attribute name="runInOptimizedMode" type="xs:boolean"
    use="optional" default="true" form="unqualified"/>
</xs:complexType>

```

```

<xs:complexType name="PipelineComponentsType">
  <xs:sequence>
    <xs:element name="component" type="DTS:PipelineComponentType"
      form="unqualified" maxOccurs="unbounded"/>
  </xs:sequence>
</xs:complexType>

<xs:complexType name="PipelinePathsType">
  <xs:sequence>
    <xs:element name="path" type="DTS:PipelinePathType"
      form="unqualified" minOccurs="0" maxOccurs="unbounded"/>
  </xs:sequence>
</xs:complexType>

<xs:complexType name="PipelineComponentType">
  <xs:sequence>
    <xs:element name="properties" form="unqualified"
      type="DTS:PipelineComponentPropertiesType"
      minOccurs="0"/>
    <xs:element name="connections" form="unqualified"
      type="DTS:PipelineComponentConnectionsType"
      minOccurs="0"/>
    <xs:element name="inputs" form="unqualified"
      type="DTS:PipelineComponentInputsType"
      minOccurs="0"/>
    <xs:element name="outputs" form="unqualified"
      type="DTS:PipelineComponentOutputsType"
      minOccurs="0"/>
  </xs:sequence>
  <!-- <xs:attribute name="id" type="xs:int" form="unqualified"/>-->
  <xs:attribute name="name" type="xs:string" form="unqualified"
    use="optional" default=""/>
  <xs:attribute name="refId" type="xs:string" use="required"
    form="unqualified"/>
  <xs:attribute name="componentClassID" use="required"
    type="DTS:PipelineComponentComponentClassIDEnum"
    form="unqualified"/>
  <xs:attribute name="description" type="xs:string"
    form="unqualified" use="optional" default=""/>
  <xs:attribute name="localeId" type="xs:int" use="optional"
    default="-1" form="unqualified"/>
  <xs:attribute name="usesDispositions" type="xs:boolean"
    use="optional" default="false" form="unqualified"/>
  <xs:attribute name="validateExternalMetadata" form="unqualified"
    use="optional" default="True">
    <xs:simpleType>
      <xs:restriction base="xs:string">
        <xs:enumeration value="True"/>
        <xs:enumeration value="False"/>
      </xs:restriction>
    </xs:simpleType>
  </xs:attribute>
  <xs:attribute name="version" type="xs:int" use="optional"
    default="0" form="unqualified"/>
  <xs:attribute name="pipelineVersion" type="xs:int"
    use="optional" default="0" form="unqualified"/>
  <xs:attribute name="contactInfo" type="xs:string"
    use="optional" default="" form="unqualified"/>
</xs:complexType>

```

```

<xs:complexType name="PipelineComponentPropertiesType">
  <xs:sequence>
    <xs:element name="property" form="unqualified"
      type="DTS:PipelineComponentPropertyType"
      minOccurs="0" maxOccurs="unbounded"/>
  </xs:sequence>
</xs:complexType>

<xs:complexType name="PipelineComponentOutputPropertiesType">
  <xs:sequence>
    <xs:element name="property" form="unqualified"
      type="DTS:PipelineComponentOutputPropertyType"
      minOccurs="0" maxOccurs="unbounded"/>
  </xs:sequence>
</xs:complexType>

<xs:complexType name="PipelineComponentInputPropertiesType">
  <xs:sequence>
    <xs:element name="property" form="unqualified"
      type="DTS:PipelineComponentInputPropertyType"
      minOccurs="0" maxOccurs="unbounded"/>
  </xs:sequence>
</xs:complexType>

<xs:complexType name="PipelineComponentConnectionsType">
  <xs:sequence>
    <xs:element name="connection" form="unqualified"
      type="DTS:PipelineComponentConnectionType"
      minOccurs="0" maxOccurs="unbounded"/>
  </xs:sequence>
</xs:complexType>

<xs:complexType name="PipelineComponentInputsType">
  <xs:sequence>
    <xs:element name="input" form="unqualified"
      type="DTS:PipelineComponentInputType"
      minOccurs="0" maxOccurs="unbounded"/>
  </xs:sequence>
</xs:complexType>

<xs:complexType name="PipelineComponentOutputsType">
  <xs:sequence>
    <xs:element name="output" form="unqualified"
      type="DTS:PipelineComponentOutputType"
      minOccurs="0" maxOccurs="unbounded"/>
  </xs:sequence>
</xs:complexType>

<xs:complexType name="Test">
  <xs:complexContent>
    <xs:restriction base="xs:anyType">
      <xs:sequence>
        <xs:element name="arrayElements" minOccurs="0">
          <xs:complexType>
            <xs:sequence>
              <xs:any minOccurs="0" maxOccurs="unbounded"/>
            </xs:sequence>
          </xs:complexType>
          <xs:anyAttribute namespace="##any" processContents="lax"/>
        </xs:element>
      </xs:sequence>
    </xs:restriction>
  </xs:complexContent>
</xs:complexType>

```

```

        </xs:complexType>
    </xs:element>
</xs:sequence>
<xs:anyAttribute namespace="##any" processContents="lax"/>
</xs:restriction>
</xs:complexContent>
</xs:complexType>

<xs:complexType name="PipelineComponentPropertyType" mixed="true">
  <xs:sequence>
    <xs:element name="arrayElements"
      type="DTS:PipelineComponentArrayElementsType"
      form="unqualified" minOccurs="0"/>
  </xs:sequence>
  <xs:attribute name="name" use="required"
    type="DTS:PipelineComponentPropertyNameEnum"
    form="unqualified"/>
  <xs:attributeGroup
    ref="DTS:PipelineComponentPropertyAttributeGroup"/>
</xs:complexType>

<xs:attributeGroup
  name="PipelineComponentPropertyAttributeGroup">
<!-- <xs:attribute name="id" type="xs:int" form="unqualified"/>-->
  <xs:attribute name="dataType"
    type="DTS:PipelineComponentDataTypeEnum"
    form="unqualified"/>
  <xs:attribute name="state"
    type="DTS:PipelineComponentStateEnum"
    form="unqualified" use="optional" default="default" />
  <xs:attribute name="isArray" type="xs:boolean"
    use="optional" default="false" form="unqualified"/>
  <xs:attribute name="description" type="xs:string"
    use="optional" default="" form="unqualified"/>
  <xs:attribute name="typeConverter" type="xs:string"
    use="optional" default="" form="unqualified"/>
  <xs:attribute name="UITypeEditor" type="xs:string"
    use="optional" default="" form="unqualified"/>
  <xs:attribute name="containsID" type="xs:boolean"
    use="optional" default="false" form="unqualified"/>
  <xs:attribute name="expressionType"
    type="DTS:PipelineComponentExpressionTypeEnum"
    use="optional" default="None" form="unqualified"/>
</xs:attributeGroup>

<xs:complexType name="PipelineComponentOutputPropertyType"
  mixed="true">
  <xs:sequence>
    <xs:element name="arrayElements"
      type="DTS:PipelineComponentArrayElementsType"
      form="unqualified" minOccurs="0"/>
  </xs:sequence>
  <xs:attributeGroup
    ref="DTS:PipelineComponentPropertyAttributeGroup"/>
  <xs:attribute name="name" use="required"
    type="DTS:PipelineComponentOutputPropertyNameEnum"
    form="unqualified"/>
</xs:complexType>

```

```

<xs:complexType name="PipelineComponentInputPropertyType"
  mixed="true">
  <xs:sequence>
    <xs:element name="arrayElements"
      type="DTS:PipelineComponentArrayElementsType"
      form="unqualified" minOccurs="0"/>
  </xs:sequence>
  <xs:attributeGroup
    ref="DTS:PipelineComponentPropertyAttributeGroup"/>
  <xs:attribute name="name" use="required"
    type="DTS:PipelineComponentInputPropertyNameEnum"
    form="unqualified"/>
</xs:complexType>

<xs:complexType name="PipelineComponentArrayElementsType">
  <xs:sequence>
    <xs:element name="arrayElement"
      type="DTS:PipelineComponentArrayElementType"
      form="unqualified" minOccurs="0" maxOccurs="unbounded"/>
  </xs:sequence>
  <xs:attribute name="arrayElementCount" type="xs:int"
    form="unqualified"/>
</xs:complexType>

<xs:complexType name="PipelineComponentArrayElementType">
  <xs:simpleContent>
    <xs:extension base="xs:anySimpleType">
      <xs:attribute name="dataType"
        type="DTS:PipelineComponentDataTypeEnum"
        form="unqualified"/>
    </xs:extension>
  </xs:simpleContent>
</xs:complexType>

<xs:simpleType name="PipelineComponentComponentClassIDEnum">
  <xs:restriction base="DTS:uuid">
    <!--Transforms-->
    <!--Aggregate-->
    <xs:enumeration value="{5B201335-B360-485C-BB93-75C34E09B3D3}"/>
    <!--Audit-->
    <xs:enumeration value="{4FCE8297-9C65-40A9-9D60-00C5CC6BC283}"/>
    <!--Cache Transform-->
    <xs:enumeration value="{BF818E79-2C1C-410D-ADEA-B2D1A04FED01}"/>
    <!--Character Map-->
    <xs:enumeration value="{C86C867A-7D40-486A-8734-F0B6943A9DD4}"/>
    <!--Conditional Split-->
    <xs:enumeration value="{7F88F654-4E20-4D14-84F4-AF9C925D3087}"/>
    <!--Copy Column-->
    <xs:enumeration value="{D231ABC4-4754-481B-8F7A-CD4BD8D09832}"/>
    <!--Data Conversion-->
    <xs:enumeration value="{62B1106C-7DB8-4EC8-ADD6-4C664DFFC54A}"/>
    <!--Data Mining Query-->
    <xs:enumeration value="{CBDF0CC-3758-4424-A431-3C2E103069AA}"/>
    <!--Derived Column-->
    <xs:enumeration value="{49928E82-9C4E-49F0-AABE-3812B82707EC}"/>
    <!--Export Column-->
    <xs:enumeration value="{A9823821-0085-4483-952F-36277F63FFC5}"/>
    <!--Fuzzy Grouping-->
    <xs:enumeration value="{836E0D0B-0358-45B4-B888-4ADCE9356D4E}"/>
  </xs:restriction>
</xs:simpleType>

```

```

<!--Fuzzy Lookup-->
<xs:enumeration value="{E4A5F949-EC93-45AB-8B36-B52936257EC2}"/>
<!--Import Column-->
<xs:enumeration value="{9053CAE0-140B-48E4-AEEC-4E6A26E9E436}"/>
<!--Lookup-->
<xs:enumeration value="{671046B0-AA63-4C9F-90E4-C06E0B710CE3}"/>
<!--Merge-->
<xs:enumeration value="{36E0E750-2510-4776-AA6E-17EAE84FD63E}"/>
<!--MergeJoin-->
<xs:enumeration value="{14D43A4F-D7BD-489D-829E-6DE35750CFE4}"/>
<!--Multicast-->
<xs:enumeration value="{EC139FBC-694E-490B-8EA7-35690FB0F445}"/>
<!--OLE DB Command-->
<xs:enumeration value="{93FFEC66-CBC8-4C7F-9C6A-CB1C17A7567D}"/>
<!--Percentage Sampling-->
<xs:enumeration value="{05322586-D434-4593-8BE4-8CFC766D9C8B}"/>
<!--Pivot-->
<xs:enumeration value="{AEB2AFAE-2201-48B1-B290-42BB8C9149DD}"/>
<!--RowCount-->
<xs:enumeration value="{E2697D8C-70DA-42B2-8208-A19CE3A9FE41}"/>
<!--Row Sampling-->
<xs:enumeration value="{284A868A-7C3D-498C-ABBF-028CEF6AB288}"/>
<!--Script Component, ADO.Net source, XML Source,ADO.Net
Destination, DataReader Destination, SQL ServerCompact Destination-->
<xs:enumeration value="{874F7595-FB5F-40FF-96AF-FBFF8250E3EF}"/>
<!--Slowly Changing Dimension-->
<xs:enumeration value="{25BBB0C5-369B-4303-B3DF-D0DC741DEE58}"/>
<!--Sort-->
<xs:enumeration value="{5B1A3FF5-D366-4D75-AD1F-F19A36FCBEDB}"/>
<!--Term Extraction-->
<xs:enumeration value="{056F53D1-8081-4D07-8134-1D4DAC244BB2}"/>
<!--Term Lookup-->
<xs:enumeration value="{ACCC729A-823D-49A7-B16D-F1999AEB1D4C}"/>
<!--Union All-->
<xs:enumeration value="{B594E9A8-4351-4939-891C-CFE1AB93E925}"/>
<!--Unpivot-->
<xs:enumeration value="{B8B094A9-8809-4E06-8874-5C55606A9FDF}"/>

<!--Destinations-->
<!--Excel Destination-->
<xs:enumeration value="{1F5D5712-2FBA-4CB9-A95A-86C1F336E1DA}"/>
<!--Flat File Destination-->
<xs:enumeration value="{8DA75FED-1B7C-407D-B2AD-2B24209CCCA4}"/>
<!--OLE DB Destination-->
<xs:enumeration value="{4ADA7EAA-136C-4215-8098-D7A7C27FC0D1}"/>
<!--Data Mining Model Training-->
<xs:enumeration value="{3D9FFAE9-B89B-43D9-80C8-B97D2740C746}"/>
<!--Dimension Processing-->
<xs:enumeration value="{2C2F0891-3AAA-4865-A676-D7476FE4CE90}"/>
<!--Partition Processing-->
<xs:enumeration value="{DA510FB7-E3A8-4D96-9F59-55E15E67FE3D}"/>
<!--Raw File-->
<xs:enumeration value="{04762BB6-892F-4EE6-AD46-9CEB0A7EC7A2}"/>
<!--RecordSet Destination-->
<xs:enumeration value="{C457FD7E-CE98-4C4B-AEFE-F3AE0044F181}"/>
<!--SQL Server Destination-->
<xs:enumeration value="{F452EAF3-5EF0-43F1-8067-09DDF0BC6316}"/>

<!--Sources-->

```



```

    <!--Excel Source-->
    <xs:enumeration value="{8C084929-27D1-479F-9641-ABB7CDADF1AC}"/>
    <!--Flat File Source-->
    <xs:enumeration value="{D23FD76B-F51D-420F-BBCB-19CBF6AC1AB4}"/>
    <!--OLE DB Source-->
    <xs:enumeration value="{165A526D-D5DE-47FF-96A6-F8274C19826B}"/>
    <!--Raw File Source-->
    <xs:enumeration value="{480C7D5A-CE63-405C-B338-3C7F26560EE3}"/>
  </xs:restriction>
</xs:simpleType>

<xs:simpleType name="PipelineComponentPropertyNameEnum">
  <xs:restriction base="xs:string">
    <!--Transforms-->
    <!--Aggregate Task-->
    <xs:enumeration value="KeyScale"/>
    <xs:enumeration value="Keys"/>
    <xs:enumeration value="CountDistinctScale"/>
    <xs:enumeration value="CountDistinctKeys"/>
    <xs:enumeration value="AutoExtendFactor"/>
    <!--Audit (none)-->
    <!--Cache Transform (none)-->
    <!--Character Map (none)-->
    <!--Conditional Split (none)-->
    <!--Copy Column (none)-->
    <!--Data Conversion (none)-->
    <!--Data Mining Query-->
    <xs:enumeration value="ObjectRef"/>
    <xs:enumeration value="QueryText"/>
    <xs:enumeration value="CatalogName"/>
    <!--Derived Column Query (none)-->
    <!--Export Column Query (none)-->
    <!--Fuzzy Grouping-->
    <xs:enumeration value="MinSimilarity"/>
    <xs:enumeration value="Delimiters"/>
    <xs:enumeration value="MaxMemoryUsage"/>
    <xs:enumeration value="Exhaustive"/>
    <!--Fuzzy Lookup-->
    <xs:enumeration value="MatchIndexOptions"/>
    <xs:enumeration value="MaxMemoryUsage"/>
    <xs:enumeration value="MatchIndexName"/>
    <xs:enumeration value="ReferenceTableName"/>
    <xs:enumeration value="DropExistingMatchIndex"/>
    <xs:enumeration value="CopyReferenceTable"/>
    <xs:enumeration value="MaxOutputMatchesPerInput"/>
    <xs:enumeration value="MinSimilarity"/>
    <xs:enumeration value="Delimiters"/>
    <xs:enumeration value="ReferenceMetadataXml"/>
    <xs:enumeration value="Exhaustive"/>
    <xs:enumeration value="WarmCaches"/>
    <!--Import Column (none)-->
    <!--Lookup-->
    <xs:enumeration value="SqlCommand"/>
    <xs:enumeration value="SqlCommandParam"/>
    <xs:enumeration value="ConnectionType"/>
    <xs:enumeration value="CacheType"/>
    <xs:enumeration value="NoMatchBehavior"/>
    <xs:enumeration value="NoMatchCachePercentage"/>
    <xs:enumeration value="MaxMemoryUsage"/>
  </xs:restriction>
</xs:simpleType>

```

```

<xs:enumeration value="MaxMemoryUsage64"/>
<xs:enumeration value="ReferenceMetadataXml"/>
<xs:enumeration value="ParameterMap"/>
<xs:enumeration value="DefaultCodePage"/>
<!--Merge (none)-->
<!--MergeJoin (none)-->
<xs:enumeration value="JoinType"/>
<xs:enumeration value="NumKeyColumns"/>
<xs:enumeration value="TreatNullsAsEqual"/>
<xs:enumeration value="MaxBuffersPerInput"/>
<!--Multicast (none)-->
<!--OLE DB Command-->
<xs:enumeration value="CommandTimeout"/>
<xs:enumeration value="SqlCommand"/>
<xs:enumeration value="DefaultCodePage"/>
<!--Percentage Sampling-->
<xs:enumeration value="SamplingValue"/>
<xs:enumeration value="SamplingSeed"/>
<!--Pivot (none)-->
<!--RowCount-->
<xs:enumeration value="VariableName"/>
<!--Row Sampling-->
<xs:enumeration value="SamplingValue"/>
<xs:enumeration value="SamplingSeed"/>
<!--Script Component-->
<xs:enumeration value="SourceCode"/>
<xs:enumeration value="BinaryCode"/>
<xs:enumeration value="VSTAProjectName"/>
<xs:enumeration value="ScriptLanguage"/>
<xs:enumeration value="ReadOnlyVariables"/>
<xs:enumeration value="ReadWriteVariables"/>
<xs:enumeration value="BreakpointCollection"/>
<xs:enumeration value="UserComponentTypeName"/>
<!--Slowly Changing Dimension-->
<xs:enumeration value="SqlCommand"/>
<xs:enumeration value="CurrentRowWhere"/>
<xs:enumeration value="UpdateChangingAttributeHistory"/>
<xs:enumeration value="FailOnFixedAttributeChange"/>
<xs:enumeration value="InferredMemberIndicator"/>
<xs:enumeration value="EnableInferredMember"/>
<xs:enumeration value="FailOnLookupFailure"/>
<xs:enumeration value="IncomingRowChangeType"/>
<xs:enumeration value="DefaultCodePage"/>
<!--Sort-->
<xs:enumeration value="EliminateDuplicates"/>
<xs:enumeration value="MaximumThreads"/>
<!--Term Extraction-->
<xs:enumeration value="NeedReferenceData"/>
<xs:enumeration value="OutTermTable"/>
<xs:enumeration value="OutTermColumn"/>
<xs:enumeration value="WordOrPhrase"/>
<xs:enumeration value="ScoreType"/>
<xs:enumeration value="FrequencyThreshold"/>
<xs:enumeration value="MaxLengthOfTerm"/>
<xs:enumeration value="IsCaseSensitive"/>
<!--Term Lookup-->
<xs:enumeration value="RefTermTable"/>
<xs:enumeration value="RefTermColumn"/>
<xs:enumeration value="IsCaseSensitive"/>

```

```

<!--UnionAll (none)-->
<!--Unpivot (none)-->

<!--Data Destinations-->
<!--ADO.Net Destination-->
<xs:enumeration value="TableOrViewName"/>
<xs:enumeration value="BatchSize"/>
<xs:enumeration value="CommandTimeout"/>
<xs:enumeration value="UserComponentTypeName"/>
<!--Excel Destination-->
<xs:enumeration value="CommandTimeout"/>
<xs:enumeration value="OpenRowset"/>
<xs:enumeration value="OpenRowsetVariable"/>
<xs:enumeration value="SqlCommand"/>
<xs:enumeration value="AccessMode"/>
<xs:enumeration value="FastLoadKeepIdentity"/>
<xs:enumeration value="FastLoadKeepNulls"/>
<xs:enumeration value="FastLoadOptions"/>
<xs:enumeration value="FastLoadMaxInsertCommitSize"/>
<!--Flat File Destination-->
<xs:enumeration value="Overwrite"/>
<xs:enumeration value="Header"/>
<!--OLE DB Destination-->
<xs:enumeration value="CommandTimeout"/>
<xs:enumeration value="OpenRowset"/>
<xs:enumeration value="OpenRowsetVariable"/>
<xs:enumeration value="SqlCommand"/>
<xs:enumeration value="DefaultCodePage"/>
<xs:enumeration value="AlwaysUseDefaultCodePage"/>
<xs:enumeration value="AccessMode"/>
<xs:enumeration value="FastLoadKeepIdentity"/>
<xs:enumeration value="FastLoadKeepNulls"/>
<xs:enumeration value="FastLoadOptions"/>
<xs:enumeration value="FastLoadMaxInsertCommitSize"/>
<!--Raw File Destination-->
<xs:enumeration value="AccessMode"/>
<xs:enumeration value="FileName"/>
<xs:enumeration value="FileNameVariable"/>
<xs:enumeration value="WriteOption"/>
<!--DataReader Destination-->
<xs:enumeration value="ReadTimeout"/>
<xs:enumeration value="DataReader"/>
<xs:enumeration value="FailOnTimeout"/>
<xs:enumeration value="UserComponentTypeName"/>
<!--Data Mining Model Training-->
<xs:enumeration value="ObjectRef"/>
<!--Dimension Processing-->
<xs:enumeration value="ObjectRef"/>
<xs:enumeration value="UseDefaultConfiguration"/>
<xs:enumeration value="KeyErrorLimit"/>
<xs:enumeration value="KeyErrorLogFile"/>
<xs:enumeration value="KeyErrorAction"/>
<xs:enumeration value="KeyErrorLimitAction"/>
<xs:enumeration value="KeyNotFound"/>
<xs:enumeration value="KeyDuplicate"/>
<xs:enumeration value="NullKeyConvertedToUnknown"/>
<xs:enumeration value="NullKeyNotAllowed"/>
<xs:enumeration value="ProcessType"/>
<!--Partition Processing-->

```

```

<xs:enumeration value="ObjectRef"/>
<xs:enumeration value="UseDefaultConfiguration"/>
<xs:enumeration value="KeyErrorLimit"/>
<xs:enumeration value="KeyErrorLogFile"/>
<xs:enumeration value="KeyErrorAction"/>
<xs:enumeration value="KeyErrorLimitAction"/>
<xs:enumeration value="KeyNotFound"/>
<xs:enumeration value="KeyDuplicate"/>
<xs:enumeration value="NullKeyConvertedToUnknown"/>
<xs:enumeration value="NullKeyNotAllowed"/>
<xs:enumeration value="ProcessType"/>
<!--RecordSet Destination-->
<xs:enumeration value="VariableName"/>
<!--SQL Server Compact Destination-->
<xs:enumeration value="Table Name"/>
<xs:enumeration value="UserComponentTypeName"/>
<!--SQL Server Destination-->
<xs:enumeration value="DefaultCodePage"/>
<xs:enumeration value="AlwaysUseDefaultCodePage"/>
<xs:enumeration value="BulkInsertTableName"/>
<xs:enumeration value="BulkInsertCheckConstraints"/>
<xs:enumeration value="BulkInsertFirstRow"/>
<xs:enumeration value="BulkInsertFireTriggers"/>
<xs:enumeration value="BulkInsertKeepIdentity"/>
<xs:enumeration value="BulkInsertKeepNulls"/>
<xs:enumeration value="BulkInsertLastRow"/>
<xs:enumeration value="BulkInsertMaxErrors"/>
<xs:enumeration value="BulkInsertOrder"/>
<xs:enumeration value="BulkInsertTablock"/>
<xs:enumeration value="Timeout"/>
<xs:enumeration value="MaxInsertCommitSize"/>

<!--Data Sources-->
<!--ADO.Net Source-->
<xs:enumeration value="SqlCommand"/>
<xs:enumeration value="CommandTimeout"/>
<xs:enumeration value="AllowImplicitStringConversion"/>
<xs:enumeration value="TableOrViewName"/>
<xs:enumeration value="AccessMode"/>
<xs:enumeration value="UserComponentTypeName"/>
<!--Excel Source-->
<xs:enumeration value="CommandTimeout"/>
<xs:enumeration value="OpenRowset"/>
<xs:enumeration value="OpenRowsetVariable"/>
<xs:enumeration value="SqlCommand"/>
<xs:enumeration value="SqlCommandVariable"/>
<xs:enumeration value="AccessMode"/>
<xs:enumeration value="ParameterMapping"/>
<!--Flat File Source-->
<xs:enumeration value="RetainNulls"/>
<xs:enumeration value="FileNameColumnName"/>
<!--OLEDB Source Task-->
<xs:enumeration value="CommandTimeout"/>
<xs:enumeration value="OpenRowset"/>
<xs:enumeration value="OpenRowsetVariable"/>
<xs:enumeration value="SqlCommand"/>
<xs:enumeration value="SqlCommandVariable"/>
<xs:enumeration value="DefaultCodePage"/>
<xs:enumeration value="AlwaysUseDefaultCodePage"/>

```

```

    <xs:enumeration value="AccessMode"/>
    <xs:enumeration value="ParameterMapping"/>
    <!--Raw File Source-->
    <xs:enumeration value="AccessMode"/>
    <xs:enumeration value="FileName"/>
    <xs:enumeration value="FileNameVariable"/>
    <!--XML Source-->
    <xs:enumeration value="UserComponentTypeName"/>
    <xs:enumeration value="XMLData"/>
    <xs:enumeration value="XMLDataVariable"/>
    <xs:enumeration value="AccessMode"/>
    <xs:enumeration value="XMLSchemaDefinition"/>
    <xs:enumeration value="UseInlineSchema"/>

  </xs:restriction>
</xs:simpleType>

<xs:simpleType name="PipelineComponentOutputPropertyNameEnum">
  <xs:restriction base="xs:string">
    <!--Transforms-->
    <!--Aggregate Task-->
    <xs:enumeration value="KeyScale"/>
    <xs:enumeration value="Keys"/>
    <!--Audit (none)-->
    <!--Cache Transform (none)-->
    <!--Character Map (none)-->
    <!--Conditional Split-->
    <xs:enumeration value="Expression"/>
    <xs:enumeration value="FriendlyExpression"/>
    <xs:enumeration value="EvaluationOrder"/>
    <xs:enumeration value="IsDefaultOut"/>
    <!--Copy Column (none)-->
    <!--Data Conversion (none)-->
    <!--Data Mining Query (none)-->
    <!--Derived Column Query (none)-->
    <!--Export Column Query (none)-->
    <!--Fuzzy Grouping (none)-->
    <!--Fuzzy Lookup (none)-->
    <!--Import Column (none)-->
    <!--Lookup (none)-->
    <!--Merge (none)-->
    <!--MergeJoin (none)-->
    <!--Multicast (none)-->
    <!--OLE DB Command (none)-->
    <!--Percentage Sampling-->
    <xs:enumeration value="Selected"/>
    <!--Pivot (none)-->
    <!--RowCount (none)-->
    <!--Row Sampling-->
    <xs:enumeration value="Selected"/>
    <!--Script Component (none)-->
    <!--Slowly Changing Dimension (none)-->
    <!--Sort (none)-->
    <!--Term Extraction (none)-->
    <!--Term Lookup (none)-->
    <!--UnionAll (none)-->
    <!--Unpivot (none)-->

    <!--Data Sources (none)-->
  
```

```

    <!--ADO.Net Source (none)-->
    <!--Excel Source (none)-->
    <!--Flat File Source (none)-->
    <!--OLEDB Source Task (none)-->
    <!--Raw File Source (none)-->
    <!--XML Source-->
    <xs:enumeration value="RowsetID"/>
  </xs:restriction>
</xs:simpleType>

<xs:simpleType name="PipelineComponentInputPropertyNameEnum">
  <xs:restriction base="xs:string">
    </xs:restriction>
    <!--None of the components have defined properties for
    the Input element-->
  </xs:simpleType>

<xs:simpleType name="PipelineComponentOutputColumnNameEnum">
  <xs:restriction base="xs:string">
    <!--Transforms-->
    <!--Aggregate Task-->
    <xs:enumeration value="AggregationColumnId"/>
    <xs:enumeration value="AggregationType"/>
    <xs:enumeration value="IsBig"/>
    <xs:enumeration value="AggregationComparisonFlags"/>
    <xs:enumeration value="CountDistinctKey"/>
    <xs:enumeration value="CountDistinctScale"/>
    <!--Audit-->
    <xs:enumeration value="LineageItemSelected"/>
    <!--Cache Transform (none)-->
    <!--Character Map (none)-->
    <!--Conditional Split (none)-->
    <!--Copy Column (none)-->
    <xs:enumeration value="copyColumnId"/>
    <!--Data Conversion (none)-->
    <xs:enumeration value="SourceInputColumnLineageID"/>
    <xs:enumeration value="FastParse"/>
    <!--Data Mining Query-->
    <!--Derived Column Query (none)-->
    <xs:enumeration value="Expression"/>
    <xs:enumeration value="FriendlyExpression"/>
    <!--Export Column Query (none)-->
    <!--Fuzzy Grouping-->
    <xs:enumeration value="ColumnType"/>
    <xs:enumeration value="InputId"/>
    <!--Fuzzy Lookup-->
    <xs:enumeration value="CopyFromReferenceColumn"/>
    <xs:enumeration value="SourceInputColumnLineageID"/>
    <xs:enumeration value="ColumnType"/>
    <!--Import Column (none)-->
    <!--Lookup-->
    <xs:enumeration value="CopyFromReferenceColumn"/>
    <!--Merge (none)-->
    <!--MergeJoin-->
    <xs:enumeration value="InputColumnID"/>
    <!--Multicast (none)-->
    <!--OLE DB Command (none)-->
    <!--Percentage Sampling (none)-->
    <!--Pivot-->
  </xs:restriction>
</xs:simpleType>

```

```

<xs:enumeration value="SourceColumn"/>
<xs:enumeration value="PivotKeyValue"/>
<!--RowCount (none)-->
<!--Row Sampling-->
<xs:enumeration value="InputColumnLineageID"/>
<!--Script Component (none)-->
<!--Slowly Changing Dimension (none)-->
<!--Sort-->
<xs:enumeration value="SortColumnId"/>
<!--Term Extraction (none)-->
<!--Term Lookup-->
<xs:enumeration value="CustomLineageID"/>
<!--UnionAll (none)-->
<!--Unpivot (none)-->
<xs:enumeration value="PivotKey"/>

<!--Data Sources-->
<!--ADO.Net Source (none)-->
<!--Excel Source (none)-->
<!--Flat File Source-->
<xs:enumeration value="FastParse"/>
<xs:enumeration value="UseBinaryFormat"/>
<!--OLEDB Source Task (none)-->
<!--Raw File Source (none)-->
<!--XML Source (none)-->
</xs:restriction>
</xs:simpleType>

<xs:simpleType name="PipelineComponentInputColumnPropertyNameEnum">
  <xs:restriction base="xs:string">
    <!--Transforms-->
    <!--Aggregate Task-->
    <!--Audit (none)-->
    <!--Cache Transform-->
    <xs:enumeration value="CacheColumnName"/>
    <!--Character Map-->
    <xs:enumeration value="MapFlags"/>
    <!--Conditional Split (none)-->
    <!--Copy Column (none)-->
    <!--Data Conversion (none)-->
    <!--Data Mining Query (none)-->
    <!--Derived Column Query-->
    <xs:enumeration value="Expression"/>
    <xs:enumeration value="FriendlyExpression"/>
    <!--Export Column-->
    <xs:enumeration value="FileDataColumnID"/>
    <xs:enumeration value="WriteBOM"/>
    <xs:enumeration value="ForceTruncate"/>
    <xs:enumeration value="AllowAppend"/>
    <!--Fuzzy Grouping-->
    <xs:enumeration value="ToBeCleaned"/>
    <xs:enumeration value="ExactFuzzy"/>
    <xs:enumeration value="LeadingTrailingNumeralsSignificant"/>
    <xs:enumeration value="MinSimilarity"/>
    <xs:enumeration value="FuzzyComparisonFlags"/>
    <!--Fuzzy Lookup-->
    <xs:enumeration value="JoinType"/>
    <xs:enumeration value="ExactFuzzy"/>
    <xs:enumeration value="JoinToReferenceColumn"/>
  </xs:restriction>
</xs:simpleType>

```

```

<xs:enumeration value="FuzzyComparisonFlags"/>
<xs:enumeration value="FuzzyComparisonFlagsEx"/>
<!--Import Column-->
<xs:enumeration value="FileDataColumnID"/>
<xs:enumeration value="ExpectBOM"/>
<!--Lookup-->
<xs:enumeration value="JoinToReferenceColumn"/>
<xs:enumeration value="CopyFromReferenceColumn"/>
<!--Merge-->
<xs:enumeration value="OutputColumnLineageID"/>
<!--MergeJoin (none)-->
<!--Multicast (none)-->
<!--OLE DB Command (none)-->
<!--Percentage Sampling (none)-->
<!--Pivot-->
<xs:enumeration value="PivotUsage"/>
<!--RowCount (none)-->
<!--Row Sampling (none)-->
<!--Script Component (none)-->
<!--Slowly Changing Dimension-->
<xs:enumeration value="ColumnType"/>
<!--Sort-->
<xs:enumeration value="NewComparisonFlags"/>
<xs:enumeration value="NewSortKeyPosition"/>
<!--Term Extraction (none)-->
<!--Term Lookup-->
<xs:enumeration value="InputColumnType"/>
<!--UnionAll-->
<xs:enumeration value="OutputColumnLineageID"/>
<!--Unpivot-->
<xs:enumeration value="DestinationColumn"/>
<xs:enumeration value="PivotKeyValue"/>

<!--Data Destinations-->
<!--ADO.Net Destination (none)-->
<!--Excel Destination (none)-->
<!--Flat File Destination (none)-->
<!--OLE DB Destination (none)-->
<!--Raw File Destination (none)-->
<!--DataReader Destination (none)-->
<!--Data Mining Model Training (none)-->
<!--Dimension Processing (none)-->
<!--Partition Processing (none)-->
<!--RecordSet Destination (none)-->
<!--SQL Server Compact Destination (none)-->
<!--SQL Server Destination (none)-->
</xs:restriction>
</xs:simpleType>

<xs:simpleType name="PipelineComponentDataTypeEnum">
  <xs:restriction base="xs:string">
    <xs:enumeration value="System.Boolean"/>
    <xs:enumeration value="System.Byte"/>
    <xs:enumeration value="System.SByte"/>
    <xs:enumeration value="System.Decimal"/>
    <xs:enumeration value="System.Double"/>
    <xs:enumeration value="System.Single"/>
    <xs:enumeration value="System.Int32"/>
    <xs:enumeration value="System.UInt32"/>
  </xs:restriction>
</xs:simpleType>

```



```

    <xs:enumeration value="System.Int64"/>
    <xs:enumeration value="System.UInt64"/>
    <xs:enumeration value="System.Int16"/>
    <xs:enumeration value="System.UInt16"/>
    <xs:enumeration value="System.String"/>
    <xs:enumeration value="System.Null"/>
    <xs:enumeration value="System.DateTime"/>
    <xs:enumeration value="System.Object"/>
  </xs:restriction>
</xs:simpleType>

<xs:simpleType name="PipelineComponentStateEnum">
  <xs:restriction base="xs:string">
    <xs:enumeration value="cdata"/>
    <xs:enumeration value="escaped"/>
    <xs:enumeration value="default"/>
  </xs:restriction>
</xs:simpleType>

<xs:simpleType name="PipelineComponentExpressionTypeEnum">
  <xs:restriction base="xs:string">
    <xs:enumeration value="None"/>
    <xs:enumeration value="Notify"/>
  </xs:restriction>
</xs:simpleType>

<xs:complexType name="PipelineComponentConnectionType">
  <xs:sequence>
    <xs:attribute name="refId" type="xs:string" use="required"
      form="unqualified"/>
    <xs:attribute name="name" type="xs:string" use="optional"
      default="" form="unqualified"/>
    <xs:attribute name="description" type="xs:string"
      use="optional" default="" form="unqualified"/>
    <xs:attribute name="connectionManagerID" type="xs:string"
      use="optional" default="" form="unqualified"/>
  </xs:sequence>
</xs:complexType>

<xs:complexType name="PipelineComponentInputType">
  <xs:sequence>
    <xs:element name="properties"
      type="DTS:PipelineComponentInputPropertiesType"
      minOccurs="0" form="unqualified"/>
    <xs:element name="inputColumns"
      type="DTS:PipelineComponentInputColumnsType"
      minOccurs="0" form="unqualified"/>
    <xs:element name="externalMetadataColumns"
      type="DTS:PipelineComponentMetadataColumnsType"
      minOccurs="0" form="unqualified"/>
  </xs:sequence>
  <xs:attributeGroup
    ref="DTS:PipelineComponentInputOutputElementAttributeGroup"/>
</xs:complexType>

<xs:complexType name="PipelineComponentInputColumnsType">
  <xs:sequence>
    <xs:element name="inputColumn"
      type="DTS:PipelineComponentInputColumnType"
      minOccurs="0" maxOccurs="unbounded" form="unqualified"/>
  </xs:sequence>
</xs:complexType>

```

```

    </xs:sequence>
</xs:complexType>

<xs:complexType name="PipelineComponentInputColumnType">
  <xs:sequence>
    <xs:element name="properties"
      type="DTS:PipelineComponentInputColumnPropertiesType"
      form="unqualified" minOccurs="0" maxOccurs="unbounded"/>
  </xs:sequence>
  <xs:attributeGroup
    ref="DTS:PipelineComponentAllColumnBaseAttributeGroup"/>
  <xs:attributeGroup
    ref="DTS:PipelineComponentIOColumnBaseAttributeGroup"/>
  <xs:attribute name="usageType" form="unqualified"
    use="optional" default="readOnly"
    type="DTS:PipelineComponentUsageTypeEnum"/>
  <xs:attribute name="cachedName" type="xs:string"
    use="optional" default="" form="unqualified"/>
  <xs:attribute name="cachedSortKeyPosition" type="xs:int"
    use="optional" default="0" form="unqualified"/>
  <xs:attribute name="cachedPrecision" type="xs:int" use="optional"
    default="0" form="unqualified"/>
  <xs:attribute name="cachedScale" type="xs:int" use="optional"
    default="0" form="unqualified"/>
  <xs:attribute name="cachedLength" type="xs:int" use="optional"
    default="0" form="unqualified"/>
  <xs:attribute name="cachedDataType"
    type="DTS:PipelineComponentColumnTypeEnum"
    use="optional" default="empty" form="unqualified"/>
  <xs:attribute name="cachedCodepage" type="xs:int" use="optional"
    default="0" form="unqualified"/>
  <xs:attribute name="cachedComparisonFlags" type="xs:int"
    form="unqualified" use="optional" default="0" />
</xs:complexType>

<xs:complexType name="PipelineComponentInputColumnPropertiesType">
  <xs:sequence>
    <xs:element name="property" form="unqualified"
      type="DTS:PipelineComponentInputColumnPropertyType"
      minOccurs="0" maxOccurs="unbounded"/>
  </xs:sequence>
</xs:complexType>

<xs:complexType name="PipelineComponentInputColumnPropertyType">
  <xs:simpleContent>
    <xs:extension base="xs:anySimpleType">
      <xs:attributeGroup
        ref="DTS:PipelineComponentPropertyAttributeGroup"/>
      <xs:attribute name="name" form="unqualified" use="required"
        type="DTS:PipelineComponentInputColumnPropertyNameEnum"/>
    </xs:extension>
  </xs:simpleContent>
</xs:complexType>

<xs:complexType name="PipelineComponentOutputColumnPropertiesType">
  <xs:sequence>
    <xs:element name="property" form="unqualified"
      type="DTS:PipelineComponentOutputColumnPropertyType"
      minOccurs="0" maxOccurs="unbounded"/>
  </xs:sequence>
</xs:complexType>

```

```

    </xs:sequence>
  </xs:complexType>

  <xs:complexType name="PipelineComponentOutputColumnPropertyType">
    <xs:simpleContent>
      <xs:extension base="xs:anySimpleType">
        <xs:attributeGroup
          ref="DTS:PipelineComponentPropertyAttributeGroup"/>
        <xs:attribute name="name" form="unqualified" use="required"
          type="DTS:PipelineComponentOutputColumnPropertyNameEnum"/>
      </xs:extension>
    </xs:simpleContent>
  </xs:complexType>

  <xs:simpleType name="PipelineComponentUsageTypeEnum">
    <xs:restriction base="xs:string">
      <xs:enumeration value="readOnly"/>
      <xs:enumeration value="readWrite"/>
      <xs:enumeration value="Ignored"/>
    </xs:restriction>
  </xs:simpleType>

  <xs:complexType name="PipelineComponentOutputType">
    <xs:sequence>
      <xs:element name="properties"
        type="DTS:PipelineComponentOutputPropertiesType"
        minOccurs="0" form="unqualified"/>
      <xs:element name="outputColumns"
        type="DTS:PipelineComponentOutputColumnsType"
        minOccurs="0" form="unqualified"/>
      <xs:element name="externalMetadataColumns"
        type="DTS:PipelineComponentMetadataColumnsType"
        minOccurs="0" form="unqualified"/>
    </xs:sequence>
    <xs:attributeGroup
      ref="DTS:PipelineComponentInputOutputElementAttributeGroup"/>
    <xs:attribute name="exclusionGroup" type="xs:int"
      use="optional" default="0" form="unqualified"/>
    <xs:attribute name="synchronousInputId" type="xs:string"
      use="optional" default="0" form="unqualified"/>
    <xs:attribute name="deleteOutputOnPathDetached" type="xs:boolean"
      use="optional" default="false" form="unqualified"/>
    <xs:attribute name="isErrorOut" type="xs:boolean"
      use="optional" default="false" form="unqualified"/>
    <xs:attribute name="isSorted" type="xs:boolean" use="optional"
      default="false" form="unqualified"/>
  </xs:complexType>

  <xs:complexType name="PipelineComponentMetadataColumnsType">
    <xs:sequence>
      <xs:element name="externalMetadataColumn"
        type="DTS:PipelineComponentMetadataColumnType"
        minOccurs="0" maxOccurs="unbounded" form="unqualified"/>
    </xs:sequence>
    <xs:attribute name="isUsed" form="unqualified">
      <xs:simpleType>
        <xs:restriction base="xs:string">
          <xs:enumeration value="True"/>
          <xs:enumeration value="False"/>
        </xs:restriction>
      </xs:simpleType>
    </xs:attribute>
  </xs:complexType>

```

```

        </xs:restriction>
    </xs:simpleType>
</xs:attribute>
</xs:complexType>

<xs:complexType name="PipelineComponentMetadataColumnType">
    <xs:sequence>
        <xs:element name="properties"
            type="DTS:PipelineComponentMetadataColumnPropertiesType"
            minOccurs="0" form="unqualified"/>
    </xs:sequence>
    <xs:attributeGroup
        ref="DTS:PipelineComponentAllColumnBaseAttributeGroup"/>
    <xs:attributeGroup
        ref="DTS:PipelineComponentColumnExtendedAttributeGroup"/>
</xs:complexType>

<xs:complexType name="PipelineComponentMetadataColumnPropertiesType">
    <xs:sequence>
        <xs:element name="property"
            type="DTS:PipelineComponentMetadataColumnPropertyType"
            minOccurs="0" maxOccurs="unbounded" form="unqualified"/>
    </xs:sequence>
</xs:complexType>

<xs:complexType name="PipelineComponentMetadataColumnPropertyType">
    <xs:simpleContent>
        <xs:extension base="xs:anySimpleType">
            <xs:attributeGroup
                ref="DTS:PipelineComponentPropertyAttributeGroup"/>
            <xs:attribute name="name" form="unqualified" use="required"
                type="DTS:PipelineComponentMetadataColumnPropertyNameEnum"/>
        </xs:extension>
    </xs:simpleContent>
</xs:complexType>

<xs:simpleType name="PipelineComponentMetadataColumnPropertyNameEnum">
    <xs:restriction base="xs:string">
        <!--OLE DB Command-->
        <xs:enumeration value="DBParamInfoFlags"/>
        <!--XML Source-->
        <xs:enumeration value="CLRType"/>
    </xs:restriction>
</xs:simpleType>

<xs:attributeGroup
    name="PipelineComponentInputOutputElementAttributeGroup">
    <xs:attribute name="refId" type="xs:string" use="required"
        form="unqualified"/>
    <xs:attribute name="name" type="xs:string" use="optional" default=""
        form="unqualified"/>
    <xs:attribute name="description" type="xs:string"
        use="optional" default="" form="unqualified"/>
    <xs:attribute name="hasSideEffects" type="xs:boolean"
        use="optional" default="false" form="unqualified"/>
    <xs:attribute name="dangling" type="xs:boolean"
        use="optional" default="false" form="unqualified"/>
    <xs:attribute name="errorOrTruncationOperation" type="xs:string"
        use="optional" default="" form="unqualified"/>

```

```

    <xs:attribute name="errorRowDisposition" form="unqualified"
        type="DTS:PipelineComponentRowDispositionEnum"
        use="optional" default="NotUsed"/>
    <xs:attribute name="truncationRowDisposition" form="unqualified"
        type="DTS:PipelineComponentRowDispositionEnum"
        use="optional" default="NotUsed"/>
</xs:attributeGroup>

<xs:attributeGroup name="PipelineComponentAllColumnBaseAttributeGroup">
<!-- <xs:attribute name="id" type="xs:int" form="unqualified"/>-->
    <xs:attribute name="refId" type="xs:string" use="required"
        form="unqualified"/>
    <xs:attribute name="name" type="xs:string" use="optional" default=""
        form="unqualified"/>
    <xs:attribute name="description" type="xs:string" use="optional"
        default="" form="unqualified"/>
    <xs:attribute name="mappedColumnId" type="xs:int" use="optional"
        default="0" form="unqualified"/>
</xs:attributeGroup>

<xs:attributeGroup name="PipelineComponentIOColumnBaseAttributeGroup">
    <xs:attribute name="errorOrTruncationOperation" type="xs:string"
        use="optional" default="" form="unqualified"/>
    <xs:attribute name="errorRowDisposition"
        type="DTS:PipelineComponentRowDispositionEnum"
        form="unqualified" use="optional" default="NotUsed"/>
    <xs:attribute name="truncationRowDisposition"
        type="DTS:PipelineComponentRowDispositionEnum"
        form="unqualified" use="optional" default="NotUsed"/>
    <xs:attribute name="externalMetadataColumnId" type="xs:string"
        form="unqualified"/>
    <xs:attribute name="lineageId" type="xs:string" use="required"
        form="unqualified"/>
</xs:attributeGroup>

<xs:attributeGroup name="PipelineComponentColumnExtendedAttributeGroup">
    <xs:attribute name="precision" type="xs:int" use="optional" default="0"
        form="unqualified"/>
    <xs:attribute name="scale" type="xs:int" use="optional" default="0"
        form="unqualified"/>
    <xs:attribute name="length" type="xs:int" use="optional" default="0"
        form="unqualified"/>
    <xs:attribute name="dataType"
        type="DTS:PipelineComponentColumnDataTypeEnum"
        use="optional" default="empty" form="unqualified"/>
    <xs:attribute name="codePage" type="xs:int" use="optional" default="0"
        form="unqualified"/>
</xs:attributeGroup>

<xs:complexType name="PipelineComponentOutputColumnsType">
    <xs:sequence>
        <xs:element name="outputColumn"
            type="DTS:PipelineComponentOutputColumnType"
            minOccurs="0" maxOccurs="unbounded" form="unqualified"/>
    </xs:sequence>
</xs:complexType>

<xs:complexType name="PipelineComponentOutputColumnType">
    <xs:sequence>

```

```

    <xs:element name="properties"
      type="DTS:PipelineComponentOutputColumnPropertiesType"
      form="unqualified" minOccurs="0" maxOccurs="unbounded"/>
  </xs:sequence>
  <xs:attributeGroup
    ref="DTS:PipelineComponentAllColumnBaseAttributeGroup"/>
  <xs:attributeGroup
    ref="DTS:PipelineComponentIOColumnBaseAttributeGroup"/>
  <xs:attributeGroup
    ref="DTS:PipelineComponentColumnExtendedAttributeGroup"/>
  <xs:attribute name="sortKeyPosition" type="xs:int"
    use="optional" default="0" form="unqualified"/>
  <xs:attribute name="comparisonFlags" type="xs:int"
    form="unqualified" use="optional" default="0" />
  <xs:attribute name="specialFlags" form="unqualified"
    use="optional" default="0">
    <xs:simpleType>
      <xs:restriction base="xs:int">
        <xs:minInclusive value="0"/>
        <xs:maxInclusive value="2"/>
      </xs:restriction>
    </xs:simpleType>
  </xs:attribute>
</xs:complexType>

<xs:simpleType name="PipelineComponentColumnDataTypeEnum">
  <xs:restriction base="xs:string">
    <xs:enumeration value="empty"/>
    <xs:enumeration value="i1"/>
    <xs:enumeration value="ui1"/>
    <xs:enumeration value="i2"/>
    <xs:enumeration value="i4"/>
    <xs:enumeration value="r4"/>
    <xs:enumeration value="r8"/>
    <xs:enumeration value="cy"/>
    <xs:enumeration value="date"/>
    <xs:enumeration value="bool"/>
    <xs:enumeration value="variant"/>
    <xs:enumeration value="decimal"/>
    <xs:enumeration value="ui2"/>
    <xs:enumeration value="ui4"/>
    <xs:enumeration value="i8"/>
    <xs:enumeration value="ui8"/>
    <xs:enumeration value="guid"/>
    <xs:enumeration value="bytes"/>
    <xs:enumeration value="str"/>
    <xs:enumeration value="wstr"/>
    <xs:enumeration value="numeric"/>
    <xs:enumeration value="dbDate"/>
    <xs:enumeration value="dateTime"/>
    <xs:enumeration value="dbTime"/>
    <xs:enumeration value="dbTimeStamp"/>
    <xs:enumeration value="image"/>
    <xs:enumeration value="text"/>
    <xs:enumeration value="nText"/>
    <xs:enumeration value="dbTime2"/>
    <xs:enumeration value="dbTimeStamp2"/>
    <xs:enumeration value="dbTimeStampOffset"/>
  </xs:restriction>

```

```

</xs:simpleType>

<xs:simpleType name="PipelineComponentRowDispositionEnum">
  <xs:restriction base="xs:string">
    <xs:enumeration value="NotUsed"/>
    <xs:enumeration value="IgnoreFailure"/>
    <xs:enumeration value="FailComponent"/>
    <xs:enumeration value="RedirectRow"/>
  </xs:restriction>
</xs:simpleType>

<xs:complexType name="PipelinePathType">
  <xs:sequence/>
  <xs:attribute name="refId" type="xs:string" use="required"
    form="unqualified"/>
  <xs:attribute name="name" type="xs:string" form="unqualified"/>
  <xs:attribute name="description" type="xs:string"
    form="unqualified"/>
  <xs:attribute name="startId" type="xs:string" form="unqualified"/>
  <xs:attribute name="endId" type="xs:string" form="unqualified"/>
</xs:complexType>

<!--ObjectData for non-Executables-->

<xs:complexType name="LogProviderObjectDataType">
  <xs:sequence>
    <xs:element name="InnerObject" form="unqualified"
      type="DTS:InnerObjectObjectDataType"/>
  </xs:sequence>
</xs:complexType>

<xs:complexType name="ForEachEnumeratorObjectDataType">
  <xs:choice>
    <xs:element name="FEIEItems" type="DTS:FEIEItemsType"
      form="unqualified"/>
    <xs:element name="ForEachFileEnumeratorProperties"
      type="DTS:ForEachFileEnumeratorPropertiesType"
      form="unqualified"/>
    <xs:element name="FEEADO" type="DTS:FEEADOType"
      form="unqualified"/>
    <xs:element name="FEESchemaRowset" type="DTS:FEESchemaRowsetType"
      form="unqualified"/>
    <xs:element name="FEEFVE" type="DTS:FEEFVEType" form="unqualified"/>
    <xs:element name="FEENODELIST" type="DTS:FEENODELISTType"
      form="unqualified"/>
    <xs:element name="FEESMO" type="DTS:FEESMOType" form="unqualified"/>
  </xs:choice>
</xs:complexType>

<xs:complexType name="FEIEItemsType">
  <xs:sequence>
    <xs:element name="FEIEItem" type="DTS:FEIEItemType"
      maxOccurs="unbounded" form="unqualified"/>
  </xs:sequence>
</xs:complexType>

<xs:complexType name="FEIEItemType">
  <xs:sequence>
    <xs:element name="FEIEItemValue" maxOccurs="unbounded"

```

```

        form="unqualified" type="DTS:FEIEItemValueType"/>
    </xs:sequence>
</xs:complexType>

<xs:complexType name="FEIEItemValueType">
    <xs:sequence/>
    <xs:attribute name="Type" type="DTS:DtsDataTypeEnum"
        use="required" form="unqualified"/>
    <xs:attribute name="Value" type="xs:string"
        use="required" form="unqualified"/>
</xs:complexType>

<xs:complexType name="ForEachFileEnumeratorPropertiesType">
    <xs:sequence>
        <xs:element name="FEFEProperty" maxOccurs="unbounded" form="unqualified">
            <xs:complexType>
                <xs:sequence/>
                <xs:attribute name="Folder" form="unqualified"/>
                <xs:attribute name="FileSpec" form="unqualified"/>
                <xs:attribute name="FileNameRetrievalType" form="unqualified">
                    <xs:simpleType>
                        <xs:restriction base="xs:int">
                            <xs:minInclusive value="0"/>
                            <xs:maxInclusive value="2"/>
                        </xs:restriction>
                    </xs:simpleType>
                </xs:attribute>
                <xs:attribute name="Recurse" form="unqualified">
                    <xs:simpleType>
                        <xs:restriction base="xs:int">
                            <xs:minInclusive value="-1"/>
                            <xs:maxInclusive value="0"/>
                        </xs:restriction>
                    </xs:simpleType>
                </xs:attribute>
            </xs:complexType>
        </xs:element>
    </xs:sequence>
</xs:complexType>

<xs:complexType name="FEEADOType">
    <xs:sequence/>
    <xs:attribute name="EnumType" use="required" form="unqualified"
        type="DTS:FEEADOEnumType"/>
    <xs:attribute name="VarName" type="xs:string"
        use="required" form="unqualified"/>
</xs:complexType>

<xs:simpleType name="FEEADOEnumType">
    <xs:restriction base="xs:string">
        <xs:enumeration value="EnumerateRowsInFirstTable"/>
        <xs:enumeration value="EnumerateAllRows"/>
        <xs:enumeration value="EnumerateTables"/>
    </xs:restriction>
</xs:simpleType>

<xs:complexType name="FEESchemaRowsetType">
    <xs:sequence>
        <xs:element name="Restriction" maxOccurs="unbounded"

```



```

        form="unqualified" type="DTS:RestrictionElementType"/>
    </xs:sequence>
    <xs:attribute name="Connection" type="xs:string"
        use="required" form="unqualified"/>
    <xs:attribute name="Schema" type="DTS:uuid"
        use="required" form="unqualified"/>
</xs:complexType>

<xs:complexType name="RestrictionElementType">
    <xs:sequence/>
    <xs:attribute name="Index" type="xs:int" use="required"
        form="unqualified"/>
    <xs:attribute name="Value" type="xs:string" use="required"
        form="unqualified"/>
</xs:complexType>

<xs:complexType name="FEEFVETType">
    <xs:sequence/>
    <xs:attribute name="VariableName" type="xs:string" form="unqualified" use="required"/>
</xs:complexType>

<xs:complexType name="FEENODELISTType">
    <xs:sequence/>
    <xs:attribute name="EnumerationType"
        type="DTS:NodelistEnumerationTypeEnum"
        form="unqualified" use="required"/>
    <xs:attribute name="OuterXPathSourceType" form="unqualified"
        use="required" type="DTS:SourceTypeEnum"/>
    <xs:attribute name="OuterXPathString" type="xs:string"
        form="unqualified" use="required"/>
    <xs:attribute name="InnerElementType"
        type="DTS:NodelistInnerElementEnumerationTypeEnum"
        use="required" form="unqualified"/>
    <xs:attribute name="InnerXPathSourceType" form="unqualified"
        use="required" type="DTS:SourceTypeEnum"/>
    <xs:attribute name="InnerXPathString" type="xs:string"
        form="unqualified" use="required"/>
    <xs:attribute name="SourceType" form="unqualified"
        use="required" type="DTS:SourceTypeEnum"/>
    <xs:attribute name="SourceDocument" type="xs:string"
        use="required" form="unqualified"/>
</xs:complexType>

<xs:simpleType name="NodelistInnerElementEnumerationTypeEnum">
    <xs:restriction base="xs:string">
        <xs:enumeration value="Navigator"/>
        <xs:enumeration value="Node"/>
        <xs:enumeration value="NodeText"/>
    </xs:restriction>
</xs:simpleType>

<xs:simpleType name="NodelistEnumerationTypeEnum">
    <xs:restriction base="xs:string">
        <xs:enumeration value="Navigator"/>
        <xs:enumeration value="Node"/>
        <xs:enumeration value="NodeText"/>
        <xs:enumeration value="ElementCollection"/>
    </xs:restriction>
</xs:simpleType>

```

```

<xs:complexType name="FEESMOType">
  <xs:sequence/>
  <xs:attribute name="EnumURN" type="xs:string" form="unqualified" use="required"/>
</xs:complexType>

<xs:complexType name="ConnectionManagerObjectDataType">
  <xs:choice>
    <xs:element name="ConnectionManager" type=
      "DTS:ConnectionManagerObjectDataConnectionManagerType"/>
    <xs:element name="MsmqConnectionManager" type=
      "DTS:ConnectionManagerObjectDataMsmqConnectionManagerType"
      form="unqualified"/>
    <xs:element name="SMOServerConnectionManager" type=
      "DTS:ConnectionManagerObjectDataSMOServerConnectionManagerType"
      form="unqualified"/>
    <xs:element name="SmtplibConnectionManager" type=
      "DTS:ConnectionManagerObjectDataSmtplibConnectionManagerType"
      form="unqualified"/>
    <xs:element name="WmiConnectionManager" type=
      "DTS:ConnectionManagerObjectDataWmiConnectionManagerType"
      form="unqualified"/>
  </xs:choice>
</xs:complexType>

<xs:complexType
  name="ConnectionManagerObjectDataConnectionManagerType">
  <xs:sequence>
    <xs:choice minOccurs="0">
      <xs:element name="FlatFileColumns" type="DTS:FlatFileColumnsType"/>
      <xs:element name="CacheColumns" type="DTS:CacheColumnsType"
        maxOccurs="unbounded"/>
      <xs:element name="FtpConnection" type="DTS:FtpConnectionType"/>
      <xs:element name="HttpConnection" type="DTS:HttpConnectionType"/>
    </xs:choice>
  </xs:sequence>
  <xs:attributeGroup
    ref="DTS:ConnectionManagerConnectionManagerAttributeGroup"/>
</xs:complexType>

<xs:complexType name="FlatFileColumnsType">
  <xs:sequence>
    <xs:element name="FlatFileColumn" type="DTS:FlatFileColumnType"
      minOccurs="0" maxOccurs="unbounded"/>
  </xs:sequence>
</xs:complexType>

<xs:complexType name="FlatFileColumnType">
  <xs:sequence/>
  <xs:attributeGroup ref="DTS:BasePropertyAttributeGroup"/>
  <xs:attributeGroup ref="DTS:FlatFileColumnAttributeGroup"/>
</xs:complexType>

<xs:complexType name="CacheColumnsType">
  <xs:sequence>
    <xs:element name="CacheColumn" type="DTS:CacheColumnType"
      minOccurs="0" maxOccurs="unbounded"/>
  </xs:sequence>
</xs:complexType>

```

```

<xs:complexType name="CacheColumnType">
  <xs:sequence/>
  <xs:attributeGroup ref="DTS:BasePropertyAttributeGroup"/>
  <xs:attributeGroup ref="DTS:CacheColumnAttributeGroup"/>
</xs:complexType>

<xs:complexType name="FtpConnectionType">
  <xs:sequence>
    <xs:element name="Property"
      minOccurs="0" maxOccurs="unbounded">
      <xs:complexType>
        <xs:complexContent>
          <xs:extension base="DTS:PropertyElementBaseType">
            <xs:attribute name="Name"
              type="DTS:FtpConnectionPropertyNameEnum"
              use="required"/>
            <xs:attribute name="Sensitive" form="unqualified">
              <xs:simpleType>
                <xs:restriction base="xs:int">
                  <xs:minInclusive value="0"/>
                  <xs:maxInclusive value="1"/>
                </xs:restriction>
              </xs:simpleType>
            </xs:attribute>
            <xs:attribute name="Encrypted" form="unqualified">
              <xs:simpleType>
                <xs:restriction base="xs:int">
                  <xs:minInclusive value="0"/>
                  <xs:maxInclusive value="1"/>
                </xs:restriction>
              </xs:simpleType>
            </xs:attribute>
          </xs:extension>
        </xs:complexContent>
      </xs:complexType>
    </xs:element>
  </xs:sequence>
  <xs:attributeGroup ref="DTS:FtpConnectionAttributeGroup"/>
</xs:complexType>

<xs:complexType name="HttpConnectionType">
  <xs:sequence>
    <xs:element name="Property"
      minOccurs="0" maxOccurs="unbounded">
      <xs:complexType>
        <xs:complexContent>
          <xs:extension base="DTS:PropertyElementBaseType">
            <xs:attribute name="Name"
              type="DTS:HttpConnectionPropertyNameEnum"
              use="required"/>
            <xs:attribute name="Sensitive" form="unqualified">
              <xs:simpleType>
                <xs:restriction base="xs:int">
                  <xs:minInclusive value="0"/>
                  <xs:maxInclusive value="1"/>
                </xs:restriction>
              </xs:simpleType>
            </xs:attribute>
          </xs:extension>
        </xs:complexContent>
      </xs:complexType>
    </xs:element>
  </xs:sequence>
  <xs:attributeGroup ref="DTS:HttpConnectionAttributeGroup"/>
</xs:complexType>

```

```

        <xs:attribute name="Encrypted" form="unqualified">
            <xs:simpleType>
                <xs:restriction base="xs:int">
                    <xs:minInclusive value="0"/>
                    <xs:maxInclusive value="1"/>
                </xs:restriction>
            </xs:simpleType>
        </xs:attribute>
    </xs:extension>
</xs:complexContent>
</xs:complexType>
</xs:element>
</xs:sequence>
<xs:attributeGroup ref="DTS:HttpConnectionAttributeGroup"/>
</xs:complexType>

<xs:complexType
    name="ConnectionManagerObjectDataMsmqConnectionManagerType">
    <xs:sequence/>
    <xs:attribute name="ConnectionString" type="xs:string"
        form="unqualified"/>
</xs:complexType>

<xs:complexType
    name="ConnectionManagerObjectDataSMOServerConnectionManagerType">
    <xs:sequence>
        <xs:element name="PassWord" type=
            "DTS>PasswordElementType"
            form="unqualified"/>
    </xs:sequence>
    <xs:attribute name="ConnectionString" type="xs:string"
        form="unqualified" use="required"/>
</xs:complexType>

<xs:complexType name="PasswordElementType">
    <xs:simpleContent>
        <xs:extension base="xs:string">
            <xs:attribute name="Sensitive" form="unqualified">
                <xs:simpleType>
                    <xs:restriction base="xs:int">
                        <xs:minInclusive value="0"/>
                        <xs:maxInclusive value="1"/>
                    </xs:restriction>
                </xs:simpleType>
            </xs:attribute>
            <xs:attribute name="Encrypted" form="unqualified">
                <xs:simpleType>
                    <xs:restriction base="xs:int">
                        <xs:minInclusive value="0"/>
                        <xs:maxInclusive value="1"/>
                    </xs:restriction>
                </xs:simpleType>
            </xs:attribute>
        </xs:extension>
    </xs:simpleContent>
</xs:complexType>

<xs:complexType
    name="ConnectionManagerObjectDataSmtplibConnectionManagerType">

```

```

    <xs:sequence/>
    <xs:attribute name="ConnectionString" type="xs:string"
        form="unqualified"/>
</xs:complexType>

<xs:complexType
    name="ConnectionManagerObjectDataWmiConnectionManagerType">
    <xs:sequence>
        <xs:element name="PassWord" minOccurs="0"
            type="DTS>PasswordElementType"
            form="unqualified"/>
    </xs:sequence>
    <xs:attribute name="ConnectionString" type="xs:string"
        form="unqualified"/>
</xs:complexType>

<!--Property Element Types-->

<xs:complexType name="PropertyElementBaseType">
    <xs:simpleContent>
        <xs:extension base="xs:anySimpleType">
            <xs:attribute name="DataType" type="DTS:DtsDataTypeEnum"/>
        </xs:extension>
    </xs:simpleContent>
</xs:complexType>

<xs:complexType name="PropertyExpressionElementType">
    <xs:simpleContent>
        <xs:extension base="xs:anySimpleType">
            <xs:attribute name="Name" type="xs:string" use="required"/>
        </xs:extension>
    </xs:simpleContent>
</xs:complexType>

<!--Enumeration Types-->

<xs:simpleType name="BasePropertyNameEnum">
    <xs:restriction base="xs:string">
        <xs:enumeration value="Description"/>
        <xs:enumeration value="DTSID"/>
        <xs:enumeration value="CreationName"/>
        <xs:enumeration value="ObjectName"/>
    </xs:restriction>
</xs:simpleType>

<xs:attributeGroup name="BasePropertyAttributeGroup">
    <xs:attribute name="Description" type="xs:string" default=""
        use="optional" form="qualified"/>
    <xs:attribute name="DTSID" type="DTS:uuid" use="required"
        form="qualified"/>
    <xs:attribute name="CreationName" type="xs:string" use="required"
        form="qualified"/>
    <xs:attribute name="ObjectName" type="xs:string" use="optional"
        form="qualified"/>
</xs:attributeGroup>

<xs:simpleType name="DtsDataTypeEnum">
    <xs:restriction base="xs:int">
        <xs:enumeration value="0"/>
    </xs:restriction>
</xs:simpleType>

```

```

    <xs:enumeration value="1"/>
    <xs:enumeration value="2"/>
    <xs:enumeration value="3"/>
    <xs:enumeration value="4"/>
    <xs:enumeration value="5"/>
    <xs:enumeration value="6"/>
    <xs:enumeration value="7"/>
    <xs:enumeration value="8"/>
    <xs:enumeration value="11"/>
    <xs:enumeration value="13"/>
    <xs:enumeration value="14"/>
    <xs:enumeration value="16"/>
    <xs:enumeration value="17"/>
    <xs:enumeration value="18"/>
    <xs:enumeration value="19"/>
    <xs:enumeration value="20"/>
    <xs:enumeration value="21"/>
    <xs:enumeration value="22"/>
    <xs:enumeration value="23"/>
    <xs:enumeration value="64"/>
    <xs:enumeration value="72"/>
    <xs:enumeration value="129"/>
    <xs:enumeration value="130"/>
    <xs:enumeration value="131"/>
    <xs:enumeration value="133"/>
    <xs:enumeration value="134"/>
    <xs:enumeration value="135"/>
    <xs:enumeration value="139"/>
    <xs:enumeration value="145"/>
    <xs:enumeration value="146"/>
  </xs:restriction>
</xs:simpleType>

<xs:simpleType name="AllExecutablePropertyNameEnum">
  <xs:union memberTypes="DTS:BaseExecutablePropertyNameEnum">
    <xs:simpleType>
      <xs:restriction base="xs:string">
        <xs:enumeration value="DisableEventHandlers"/>
      </xs:restriction>
    </xs:simpleType>
  </xs:union>
</xs:simpleType>

<xs:attributeGroup name="AllExecutableAttributeGroup">
  <xs:attribute name="DisableEventHandlers" type="DTS:BooleanStringCap"
    default="False" use="optional" form="qualified"/>
</xs:attributeGroup>

<xs:simpleType name="BaseExecutablePropertyNameEnum">
  <xs:union memberTypes="DTS:BasePropertyNameEnum">
    <xs:simpleType>
      <xs:restriction base="xs:string">
        <xs:enumeration value="ForceExecValue"/>
        <xs:enumeration value="ExecValue"/>
        <xs:enumeration value="ForceExecutionResult"/>
        <xs:enumeration value="Disabled"/>
        <xs:enumeration value="FailPackageOnFailure"/>
        <xs:enumeration value="FailParentOnFailure"/>
        <xs:enumeration value="MaxErrorCount"/>
      </xs:restriction>
    </xs:simpleType>
  </xs:union>
</xs:simpleType>

```

```

        <xs:enumeration value="ISOLevel"/>
        <xs:enumeration value="LocaleID"/>
        <xs:enumeration value="TransactionOption"/>
        <xs:enumeration value="DelayValidation"/>
    </xs:restriction>
</xs:simpleType>
</xs:union>
</xs:simpleType>

<xs:attributeGroup name="BaseExecutablePropertyAttributeGroup">
    <xs:attribute name="ForceExecValue" type="DTS:BooleanStringCap"
        default="False" use="optional" form="qualified"/>
    <xs:attribute name="ExecValue" type="xs:anySimpleType" default="0"
        use="optional" form="qualified"/>
    <xs:attribute name="ForceExecutionResult" default="-1" use="optional"
        type="DTS:ForceExecutionResultEnum" form="qualified"/>
    <xs:attribute name="Disabled" type="DTS:BooleanStringCap" default="False"
        use="optional" form="qualified"/>
    <xs:attribute name="FailPackageOnFailure" type="DTS:BooleanStringCap"
        default="False" use="optional" form="qualified"/>
    <xs:attribute name="FailParentOnFailure" type="DTS:BooleanStringCap"
        default="False" use="optional" form="qualified"/>
    <xs:attribute name="MaxErrorCount" type="xs:int" default="1"
        use="optional" form="qualified"/>
    <xs:attribute name="ISOLevel" type="DTS:ISOLevelEnum"
        default="1048576" use="optional" form="qualified"/>
    <xs:attribute name="LocaleID" type="xs:int" use="optional"
        form="qualified"/>
    <xs:attribute name="TransactionOption" type="DTS:TransactionOptionEnum"
        default="1" use="optional" form="qualified"/>
    <xs:attribute name="DelayValidation" type="DTS:BooleanStringCap"
        default="False" use="optional" form="qualified"/>
    <xs:attribute name="ExecValueType" type="DTS:DtsDataTypeEnum"
        use="required" form="qualified"/>
</xs:attributeGroup>
<!--3 ENUM follow-->
<xs:simpleType name="ForceExecutionResultEnum">
    <xs:restriction base="xs:int">
        <xs:minInclusive value="-1"/>
        <xs:maxInclusive value="2"/>
    </xs:restriction>
</xs:simpleType>

<xs:simpleType name="ISOLevelEnum">
    <xs:restriction base="xs:int">
        <xs:enumeration value="-1"/>
        <xs:enumeration value="16"/>
        <xs:enumeration value="1033"/>
        <xs:enumeration value="4096"/>
        <xs:enumeration value="65536"/>
        <xs:enumeration value="1048576"/>
        <xs:enumeration value="16777216"/>
    </xs:restriction>
</xs:simpleType>

<xs:simpleType name="TransactionOptionEnum">
    <xs:restriction base="xs:int">
        <xs:minInclusive value="0"/>
        <xs:maxInclusive value="2"/>
    </xs:restriction>
</xs:simpleType>

```

```

    </xs:restriction>
</xs:simpleType>

<xs:simpleType name="ExecutableTypePackageNameEnum">
  <xs:restriction base="xs:string">
    <xs:enumeration value="PackageFormatVersion"/>
  </xs:restriction>
</xs:simpleType>

<xs:attributeGroup name="ExecutableTypePackageAttributeGroup">
  <xs:attribute name="VersionComments" type="xs:string" default=""
    use="optional" form="qualified"/>
  <xs:attribute name="CreatorName" type="xs:string" use="optional"
    form="qualified"/>
  <xs:attribute name="CreatorComputerName" type="xs:string"
    use="optional" form="qualified"/>
  <xs:attribute name="CreationDate" type="xs:dateTime" use="optional"
    form="qualified"/>
  <xs:attribute name="PackageType" type="DTS:PackageTypeEnum" default="0"
    use="optional" form="qualified"/>
  <xs:attribute name="ProtectionLevel" type="DTS:ProtectionLevelEnum"
    default="1" use="optional" form="qualified"/>
  <xs:attribute name="MaxConcurrentExecutables" type="xs:int"
    default="-1" use="optional" form="qualified"/>
  <xs:attribute name="PackagePriorityClass" default="0" use="optional"
    type="DTS:PackagePriorityClassEnum" form="qualified"/>
  <xs:attribute name="VersionMajor" type="xs:int" default="1"
    use="optional" form="qualified"/>
  <xs:attribute name="VersionMinor" type="xs:int" default="0"
    use="optional" form="qualified"/>
  <xs:attribute name="VersionBuild" type="xs:int" default="0"
    use="optional" form="qualified"/>
  <xs:attribute name="VersionGUID" type="DTS:uuid" use="optional"
    form="qualified"/>
  <xs:attribute name="EnableConfig" type="DTS:BooleanStringCap"
    default="False" use="optional" form="qualified"/>
  <xs:attribute name="CheckpointFileName" type="xs:string" default=""
    use="optional" form="qualified"/>
  <xs:attribute name="SaveCheckpoints" type="DTS:BooleanStringCap"
    default="False" use="optional" form="qualified"/>
  <xs:attribute name="CheckpointUsage" type="DTS:CheckpointUsageEnum"
    default="0" use="optional" form="qualified"/>
  <xs:attribute name="SuppressConfigurationWarnings" default="False"
    type="DTS:BooleanStringCap" use="optional"
    form="qualified"/>
  <xs:attribute name="LastModifiedProductVersion" type="xs:string"
    use="optional" form="qualified"/>
</xs:attributeGroup>
<!--4 ENUM follow-->
<xs:simpleType name="PackageTypeEnum">
  <xs:restriction base="xs:int">
    <xs:minInclusive value="0"/>
    <xs:maxInclusive value="6"/>
  </xs:restriction>
</xs:simpleType>

<xs:simpleType name="ProtectionLevelEnum">
  <xs:restriction base="xs:int">
    <xs:minInclusive value="0"/>

```



```

    <xs:maxInclusive value="5"/>
  </xs:restriction>
</xs:simpleType>

<xs:simpleType name="PackagePriorityClassEnum">
  <xs:restriction base="xs:int">
    <xs:minInclusive value="0"/>
    <xs:maxInclusive value="4"/>
  </xs:restriction>
</xs:simpleType>

<xs:simpleType name="CheckpointUsageEnum">
  <xs:restriction base="xs:int">
    <xs:minInclusive value="0"/>
    <xs:maxInclusive value="2"/>
  </xs:restriction>
</xs:simpleType>

<xs:simpleType name="AnyNonPackageExecutablePropertyNameEnum">
  <xs:union memberTypes="DTS:AllExecutablePropertyNameEnum">
    <xs:simpleType>
      <xs:restriction base="xs:string">
        <xs:enumeration value="ExecutionLocation"/>
        <xs:enumeration value="ExecutionAddress"/>
        <xs:enumeration value="TaskContact"/>
        <!--<xs:enumeration value="SqlStatementSource"/>-->
        <!--ForLoop uses these values-->
        <xs:enumeration value="InitExpression"/>
        <xs:enumeration value="EvalExpression"/>
        <xs:enumeration value="AssignExpression"/>
        <!--ForLoop and ForEachLoop use this value-->
        <xs:enumeration value="MaxConcurrent"/>
        <!--Sequence uses this value-->
        <xs:enumeration value="LockName"/>
        <!--Web Service Task uses this value-->
        <!--<xs:enumeration value="WsdlFile"/>-->
      </xs:restriction>
    </xs:simpleType>
  </xs:union>
</xs:simpleType>

<xs:attributeGroup name="AnyNonPackageExecutableAttributeGroup">
  <!--Pipeline & Tasks use these attributes-->
  <xs:attribute name="ExecutionLocation" type="xs:int" default="0"
    use="optional" form="qualified"/>
  <xs:attribute name="ExecutionAddress" type="xs:string" default=""
    use="optional" form="qualified"/>
  <xs:attribute name="TaskContact" type="xs:string" default=""
    use="optional" form="qualified"/>
  <!--ForLoop uses these attributes-->
  <xs:attribute name="InitExpression" type="xs:string" default=""
    use="optional" form="qualified"/>
  <xs:attribute name="EvalExpression" type="xs:string" use="optional"
    form="qualified"/>
  <xs:attribute name="AssignExpression" type="xs:string" default=""
    use="optional" form="qualified"/>
  <!--ForLoop and ForEachLoop use this attribute-->
  <xs:attribute name="MaxConcurrent" type="xs:int" default="1"
    use="optional" form="qualified"/>

```

```

    <!--Sequence uses this attribute-->
    <xs:attribute name="LockName" type="xs:string" default=""
        use="optional" form="qualified"/>
</xs:attributeGroup>

<xs:simpleType name="AnyNonPackageExecutableTypeExecutableTypeEnum">
    <xs:restriction base="xs:string">
        <xs:enumeration value="SSIS.Pipeline.3"/>
        <xs:enumeration
value="Microsoft.SqlServer.Dts.Tasks.ActiveXScriptTask.ActiveXScriptTask,
Microsoft.SqlServer.ActiveXScriptTask, Version=11.0.0.0, Culture=neutral,
PublicKeyToken=89845dcd8080cc91"/>
        <xs:enumeration
value="Microsoft.DataTransformationServices.Tasks.DTSProcessingTask.ASExecuteDDLTask,
Microsoft.SqlServer.ASTasks, Version=11.0.0.0, Culture=neutral,
PublicKeyToken=89845dcd8080cc91"/>
        <xs:enumeration
value="Microsoft.DataTransformationServices.Tasks.DTSProcessingTask.DTSProcessingTask,
Microsoft.SqlServer.ASTasks, Version=11.0.0.0, Culture=neutral,
PublicKeyToken=89845dcd8080cc91"/>
        <xs:enumeration value="Microsoft.SqlServer.Dts.Tasks.BulkInsertTask.BulkInsertTask,
Microsoft.SqlServer.BulkInsertTask, Version=11.0.0.0, Culture=neutral,
PublicKeyToken=89845dcd8080cc91"/>
        <xs:enumeration value="Microsoft.SqlServer.Dts.Tasks.DMQueryTask.DMQueryTask,
Microsoft.SqlServer.DMQueryTask, Version=11.0.0.0, Culture=neutral,
PublicKeyToken=89845dcd8080cc91"/>
        <xs:enumeration
value="Microsoft.SqlServer.Dts.Tasks.DataProfilingTask.DataProfilingTask,
Microsoft.SqlServer.DataProfilingTask, Version=11.0.0.0, Culture=neutral,
PublicKeyToken=89845dcd8080cc91"/>
        <xs:enumeration
value="Microsoft.SqlServer.Dts.Tasks.Exec80PackageTask.Exec80PackageTask,
Microsoft.SqlServer.Exec80PackageTask, Version=11.0.0.0, Culture=neutral,
PublicKeyToken=89845dcd8080cc91"/>
        <xs:enumeration value="SSIS.ExecutePackageTask.3"/>
        <xs:enumeration value="Microsoft.SqlServer.Dts.Tasks.ExecuteProcess.ExecuteProcess,
Microsoft.SqlServer.ExecProcTask, Version=11.0.0.0, Culture=neutral,
PublicKeyToken=89845dcd8080cc91"/>
        <xs:enumeration value="Microsoft.SqlServer.Dts.Tasks.ExecuteSQLTask.ExecuteSQLTask,
Microsoft.SqlServer.SQLTask, Version=11.0.0.0, Culture=neutral,
PublicKeyToken=89845dcd8080cc91"/>
        <xs:enumeration value="Microsoft.SqlServer.Dts.Tasks.FileSystemTask.FileSystemTask,
Microsoft.SqlServer.FileSystemTask, Version=11.0.0.0, Culture=neutral,
PublicKeyToken=89845dcd8080cc91"/>
        <xs:enumeration value="Microsoft.SqlServer.Dts.Tasks.FtpTask.FtpTask,
Microsoft.SqlServer.FtpTask, Version=11.0.0.0, Culture=neutral,
PublicKeyToken=89845dcd8080cc91"/>
        <xs:enumeration value="Microsoft.SqlServer.Dts.Tasks.MessageQueueTask.MessageQueueTask,
Microsoft.SqlServer.MSMQTask, Version=11.0.0.0, Culture=neutral,
PublicKeyToken=89845dcd8080cc91"/>
        <xs:enumeration value="Microsoft.SqlServer.Dts.Tasks.ScriptTask.ScriptTask,
Microsoft.SqlServer.ScriptTask, Version=11.0.0.0, Culture=neutral,
PublicKeyToken=89845dcd8080cc91"/>
        <xs:enumeration value="Microsoft.SqlServer.Dts.Tasks.SendMailTask.SendMailTask,
Microsoft.SqlServer.SendMailTask, Version=11.0.0.0, Culture=neutral,
PublicKeyToken=89845dcd8080cc91"/>
        <xs:enumeration
value="Microsoft.SqlServer.Dts.Tasks.TransferDatabaseTask.TransferDatabaseTask,
Microsoft.SqlServer.TransferDatabasesTask, Version=11.0.0.0, Culture=neutral,
PublicKeyToken=89845dcd8080cc91"/>
        <xs:enumeration
value="Microsoft.SqlServer.Dts.Tasks.TransferErrorMessagesTask.TransferErrorMessagesTask,

```

```

Microsoft.SqlServer.TransferErrorMessagesTask, Version=11.0.0.0, Culture=neutral,
PublicKeyToken=89845dcd8080cc91"/>
  <xs:enumeration value="Microsoft.SqlServer.Dts.Tasks.TransferJobsTask.TransferJobsTask,
Microsoft.SqlServer.TransferJobsTask, Version=11.0.0.0, Culture=neutral,
PublicKeyToken=89845dcd8080cc91"/>
  <xs:enumeration
value="Microsoft.SqlServer.Dts.Tasks.TransferLoginsTask.TransferLoginsTask,
Microsoft.SqlServer.TransferLoginsTask, Version=11.0.0.0, Culture=neutral,
PublicKeyToken=89845dcd8080cc91"/>
  <xs:enumeration
value="Microsoft.SqlServer.Dts.Tasks.TransferStoredProceduresTask.TransferStoredProceduresTask,
Microsoft.SqlServer.TransferStoredProceduresTask, Version=11.0.0.0, Culture=neutral,
PublicKeyToken=89845dcd8080cc91"/>
  <xs:enumeration
value="Microsoft.SqlServer.Dts.Tasks.TransferSqlServerObjectsTask.TransferSqlServerObjectsTask,
Microsoft.SqlServer.TransferSqlServerObjectsTask, Version=11.0.0.0, Culture=neutral,
PublicKeyToken=89845dcd8080cc91"/>
  <xs:enumeration value="Microsoft.SqlServer.Dts.Tasks.WebServiceTask.WebServiceTask,
Microsoft.SqlServer.WebServiceTask, Version=11.0.0.0, Culture=neutral,
PublicKeyToken=89845dcd8080cc91"/>
  <xs:enumeration
value="Microsoft.SqlServer.Dts.Tasks.WmiDataReaderTask.WmiDataReaderTask,
Microsoft.SqlServer.WMIDRTask, Version=11.0.0.0, Culture=neutral,
PublicKeyToken=89845dcd8080cc91"/>
  <xs:enumeration
value="Microsoft.SqlServer.Dts.Tasks.WmiEventWatcherTask.WmiEventWatcherTask,
Microsoft.SqlServer.WMIIEWTask, Version=11.0.0.0, Culture=neutral,
PublicKeyToken=89845dcd8080cc91"/>
  <xs:enumeration value="Microsoft.SqlServer.Dts.Tasks.XMLTask.XMLTask,
Microsoft.SqlServer.XMLTask, Version=11.0.0.0, Culture=neutral,
PublicKeyToken=89845dcd8080cc91"/>
  <xs:enumeration
value="Microsoft.SqlServer.Management.DatabaseMaintenance.DbMaintenanceBackupTask,
Microsoft.SqlServer.MaintenancePlanTasks, Version=11.0.0.0, Culture=neutral,
PublicKeyToken=89845dcd8080cc91"/>
  <xs:enumeration
value="Microsoft.SqlServer.Management.DatabaseMaintenance.DbMaintenanceCheckIntegrityTask,
Microsoft.SqlServer.MaintenancePlanTasks, Version=11.0.0.0, Culture=neutral,
PublicKeyToken=89845dcd8080cc91"/>
  <xs:enumeration
value="Microsoft.SqlServer.Management.DatabaseMaintenance.DbMaintenanceExecuteAgentJobTask,
Microsoft.SqlServer.MaintenancePlanTasks, Version=11.0.0.0, Culture=neutral,
PublicKeyToken=89845dcd8080cc91"/>
  <xs:enumeration
value="Microsoft.SqlServer.Management.DatabaseMaintenance.DbMaintenanceHistoryCleanupTask,
Microsoft.SqlServer.MaintenancePlanTasks, Version=11.0.0.0, Culture=neutral,
PublicKeyToken=89845dcd8080cc91"/>
  <xs:enumeration
value="Microsoft.SqlServer.Management.DatabaseMaintenance.DbMaintenanceFileCleanupTask,
Microsoft.SqlServer.MaintenancePlanTasks, Version=11.0.0.0, Culture=neutral,
PublicKeyToken=89845dcd8080cc91"/>
  <xs:enumeration
value="Microsoft.SqlServer.Management.DatabaseMaintenance.DbMaintenanceNotifyOperatorTask,
Microsoft.SqlServer.MaintenancePlanTasks, Version=11.0.0.0, Culture=neutral,
PublicKeyToken=89845dcd8080cc91"/>
  <xs:enumeration
value="Microsoft.SqlServer.Management.DatabaseMaintenance.DbMaintenanceReindexTask,
Microsoft.SqlServer.MaintenancePlanTasks, Version=11.0.0.0, Culture=neutral,
PublicKeyToken=89845dcd8080cc91"/>
  <xs:enumeration
value="Microsoft.SqlServer.Management.DatabaseMaintenance.DbMaintenanceDefragmentIndexTask,
Microsoft.SqlServer.MaintenancePlanTasks, Version=11.0.0.0, Culture=neutral,
PublicKeyToken=89845dcd8080cc91"/>

```

```

    <xs:enumeration
value="Microsoft.SqlServer.Management.DatabaseMaintenance.DbMaintenanceShrinkTask,
Microsoft.SqlServer.MaintenancePlanTasks, Version=11.0.0.0, Culture=neutral,
PublicKeyToken=89845dcd8080cc91"/>
    <xs:enumeration
value="Microsoft.SqlServer.Management.DatabaseMaintenance.DbMaintenanceUpdateStatisticsTask,
Microsoft.SqlServer.MaintenancePlanTasks, Version=11.0.0.0, Culture=neutral,
PublicKeyToken=89845dcd8080cc91"/>
    <xs:enumeration
value="Microsoft.SqlServer.Management.DatabaseMaintenance.DbMaintenanceTSQLExecuteTask,
Microsoft.SqlServer.MaintenancePlanTasks, Version=11.0.0.0, Culture=neutral,
PublicKeyToken=89845dcd8080cc91"/>
    <xs:enumeration value="STOCK:FORLOOP"/>
    <xs:enumeration value="STOCK:FOREACHLOOP"/>
    <xs:enumeration value="STOCK:SEQUENCE"/>
    <xs:enumeration value="STOCK:ActiveXScriptTask"/>
    <xs:enumeration value="STOCK:BulkInsertTask"/>
    <xs:enumeration value="STOCK:ExecuteProcessTask"/>
    <xs:enumeration value="STOCK:ExecutePackageTask"/>
    <xs:enumeration value="STOCK:Exec80PackageTask"/>
    <xs:enumeration value="STOCK:FileSystemTask"/>
    <xs:enumeration value="STOCK:FTPTask"/>
    <xs:enumeration value="STOCK:MSMQTask"/>
    <xs:enumeration value="STOCK:PipelineTask"/>
    <xs:enumeration value="STOCK:ScriptTask"/>
    <xs:enumeration value="STOCK:SendMailTask"/>
    <xs:enumeration value="STOCK:SQLTask"/>
    <xs:enumeration value="STOCK:TransferStoredProceduresTask"/>
    <xs:enumeration value="STOCK:TransferLoginsTask"/>
    <xs:enumeration value="STOCK:TransferErrorMessagesTask"/>
    <xs:enumeration value="STOCK:TransferJobsTask"/>
    <xs:enumeration value="STOCK:TransferObjectsTask"/>
    <xs:enumeration value="STOCK:TransferDatabaseTask"/>
    <xs:enumeration value="STOCK:WebServiceTask"/>
    <xs:enumeration value="STOCK:WmiDataReaderTask"/>
    <xs:enumeration value="STOCK:WmiEventWatcherTask"/>
    <xs:enumeration value="STOCK:XMLTask"/>
  </xs:restriction>
</xs:simpleType>

<xs:simpleType name="LogProviderPropertyNameEnum">
  <xs:union memberTypes="DTS:BasePropertyNameEnum">
    <xs:simpleType>
      <xs:restriction base="xs:string">
        <xs:enumeration value="DelayValidation"/>
        <xs:enumeration value="ConfigString"/>
      </xs:restriction>
    </xs:simpleType>
  </xs:union>
</xs:simpleType>

<xs:attributeGroup name="LogProviderAttributeGroup">
  <xs:attribute name="DelayValidation" type="DTS:BooleanStringCap"
    default="False" use="optional" form="qualified"/>
  <xs:attribute name="ConfigString" type="xs:string" default=""
    use="optional" form="qualified"/>
</xs:attributeGroup>

<xs:simpleType name="PackageVariablePropertyNameEnum">
  <xs:union memberTypes="DTS:BasePropertyNameEnum">

```

```

    <xs:simpleType>
      <xs:restriction base="xs:string">
        <xs:enumeration value="PackageVariableValue"/>
        <xs:enumeration value="PackageVariable"/>
        <xs:enumeration value="Namespace"/>
      </xs:restriction>
    </xs:simpleType>
  </xs:union>
</xs:simpleType>

<xs:simpleType name="ConfigurationPropertyNameEnum">
  <xs:union memberTypes="DTS:BasePropertyNameEnum">
    <xs:simpleType>
      <xs:restriction base="xs:string">
        <xs:enumeration value="ConfigurationType"/>
        <xs:enumeration value="ConfigurationString"/>
        <xs:enumeration value="ConfigurationVariable"/>
      </xs:restriction>
    </xs:simpleType>
  </xs:union>
</xs:simpleType>

<xs:attributeGroup name="ConfigurationAttributeGroup">
  <xs:attribute name="ConfigurationType" type="DTS:ConfigurationTypeEnum"
    default="0" use="optional" form="qualified"/>
  <xs:attribute name="ConfigurationString" type="xs:string" default=""
    use="optional" form="qualified"/>
  <xs:attribute name="ConfigurationVariable" type="xs:string" default=""
    use="optional" form="qualified"/>
</xs:attributeGroup>
<!--1 ENUM follows-->
<xs:simpleType name="ConfigurationTypeEnum">
  <xs:restriction base="xs:int">
    <xs:minInclusive value="0"/>
    <xs:maxInclusive value="10"/>
  </xs:restriction>
</xs:simpleType>

<xs:simpleType name="PrecedenceConstraintPropertyNameEnum">
  <xs:union memberTypes="DTS:BasePropertyNameEnum">
    <xs:simpleType>
      <xs:restriction base="xs:string">
        <xs:enumeration value="Value"/>
        <xs:enumeration value="EvalOp"/>
        <xs:enumeration value="LogicalAnd"/>
        <xs:enumeration value="Expression"/>
      </xs:restriction>
    </xs:simpleType>
  </xs:union>
</xs:simpleType>

<xs:attributeGroup name="PrecedenceConstraintAttributeGroup">
  <xs:attribute name="Value" type="DTS:PrecedenceConstraintValueEnum"
    use="optional" default="0" form="qualified"/>
  <xs:attribute name="EvalOp" type="DTS:PrecedenceConstraintEvalOpEnum"
    use="optional" default="1" form="qualified"/>
  <xs:attribute name="LogicalAnd" type="DTS:BooleanStringCap"
    use="optional" default="False" form="qualified"/>
  <xs:attribute name="Expression" type="xs:string" use="optional"

```

```

        default="" form="qualified"/>
    <xs:attribute name="From" type="xs:string" use="required"
        form="qualified"/>
    <xs:attribute name="To" type="xs:string" use="required"
        form="qualified"/>
</xs:attributeGroup>
<!--2 ENUM follow-->
<xs:simpleType name="PrecedenceConstraintValueEnum">
    <xs:restriction base="xs:int">
        <xs:minInclusive value="0"/>
        <xs:maxInclusive value="2"/>
    </xs:restriction>
</xs:simpleType>

<xs:simpleType name="PrecedenceConstraintEvalOpEnum">
    <xs:restriction base="xs:int">
        <xs:minInclusive value="1"/>
        <xs:maxInclusive value="4"/>
    </xs:restriction>
</xs:simpleType>

<xs:simpleType name="LoggingOptionsPropertyNameEnum">
    <xs:restriction base="xs:string">
        <xs:enumeration value="EventFilter"/>
        <xs:enumeration value="ColumnFilter"/>
    </xs:restriction>
</xs:simpleType>

<xs:attributeGroup name="LoggingOptionsAttributeGroup">
    <xs:attribute name="LoggingMode" type="DTS:LoggingModeEnum" default="0"
        use="optional" form="qualified"/>
    <xs:attribute name="FilterKind" type="DTS:FilterKindEnum" default="1"
        use="optional" form="qualified"/>
    <xs:attribute name="EventFilter" type="xs:string" default=""
        use="optional" form="qualified"/>
</xs:attributeGroup>
<!--2 ENUM follow-->
<xs:simpleType name="LoggingModeEnum">
    <xs:restriction base="xs:int">
        <xs:minInclusive value="0"/>
        <xs:maxInclusive value="2"/>
    </xs:restriction>
</xs:simpleType>

<xs:simpleType name="FilterKindEnum">
    <xs:restriction base="xs:int">
        <xs:enumeration value="0"/>
        <xs:enumeration value="1"/>
    </xs:restriction>
</xs:simpleType>

<xs:simpleType name="ColumnEventFilterPropertyNameEnum">
    <xs:restriction base="xs:string">
        <xs:enumeration value="Computer"/>
        <xs:enumeration value="Operator"/>
        <xs:enumeration value="SourceName"/>
        <xs:enumeration value="SourceID"/>
        <xs:enumeration value="ExecutionID"/>
        <xs:enumeration value="MessageText"/>
    </xs:restriction>
</xs:simpleType>

```

```

    <xs:enumeration value="DataBytes"/>
  </xs:restriction>
</xs:simpleType>

<xs:simpleType name="ForEachVariableMappingPropertyNameEnum">
  <xs:union memberTypes="DTS:BasePropertyNameEnum">
    <xs:simpleType>
      <xs:restriction base="xs:string">
        <xs:enumeration value="VariableName"/>
        <xs:enumeration value="ValueIndex"/>
      </xs:restriction>
    </xs:simpleType>
  </xs:union>
</xs:simpleType>

<xs:attributeGroup name="ForEachVariableMappingAttributeGroup">
  <xs:attribute name="VariableName" type="xs:string" use="required"
    form="qualified"/>
  <xs:attribute name="ValueIndex" type="xs:int" use="required"
    form="qualified"/>
</xs:attributeGroup>

<xs:simpleType name="VariablePropertyNameEnum">
  <xs:union memberTypes="DTS:BasePropertyNameEnum">
    <xs:simpleType>
      <xs:restriction base="xs:string">
        <xs:enumeration value="Namespace"/>
        <xs:enumeration value="Expression"/>
        <xs:enumeration value="EvaluateAsExpression"/>
        <xs:enumeration value="ReadOnly"/>
        <xs:enumeration value="RaiseChangedEvent"/>
        <xs:enumeration value="IncludeInDebugDump"/>
        <xs:enumeration value="Expression"/>
      </xs:restriction>
    </xs:simpleType>
  </xs:union>
</xs:simpleType>

<xs:attributeGroup name="VariableAttributeGroup">
  <xs:attribute name="Namespace" type="xs:string" use="optional"
    default="" form="qualified"/>
  <xs:attribute name="Expression" type="xs:string" use="optional"
    default="" form="qualified"/>
  <xs:attribute name="EvaluateAsExpression" type="DTS:BooleanStringCap"
    use="optional" default="False" form="qualified"/>
  <xs:attribute name="ReadOnly" type="DTS:BooleanStringCap" use="optional"
    default="False" form="qualified"/>
  <xs:attribute name="RaiseChangedEvent" type="DTS:BooleanStringCap"
    use="optional" default="False" form="qualified"/>
  <xs:attribute name="IncludeInDebugDump" type="xs:int" use="optional"
    default="0" form="qualified"/>
</xs:attributeGroup>
<!--1 ENUM follows-->
<xs:simpleType name="IncludeInDebugDumpEnum">
  <xs:restriction base="xs:int">
    <xs:enumeration value="2345"/>
    <xs:enumeration value="6789"/>
  </xs:restriction>
</xs:simpleType>

```

```

<xs:simpleType name="BooleanStringCap">
  <xs:restriction base="xs:string">
    <xs:enumeration value="True"/>
    <xs:enumeration value="False"/>
  </xs:restriction>
</xs:simpleType>

<xs:simpleType name="ConnectionManagerPropertyNameEnum">
  <xs:union memberTypes="DTS:BasePropertyNameEnum">
    <xs:simpleType>
      <xs:restriction base="xs:string">
        <xs:enumeration value="DelayValidation"/>
      </xs:restriction>
    </xs:simpleType>
  </xs:union>
</xs:simpleType>

<xs:attributeGroup name="ConnectionManagerAttributeGroup">
  <xs:attribute name="DelayValidation" type="DTS:BooleanStringCap"
    default="False" use="optional" form="qualified"/>
</xs:attributeGroup>

<xs:simpleType name="ConnectionManagerObjectDataPropertyNameEnum">
  <xs:restriction base="xs:string">
    <xs:enumeration value="Retain"/>
    <xs:enumeration value="ConnectionString"/>
    <xs:enumeration value="FileUsageType"/>
    <xs:enumeration value="Format"/>
    <xs:enumeration value="LocaleID"/>
    <xs:enumeration value="Unicode"/>
    <xs:enumeration value="HeaderRowsToSkip"/>
    <xs:enumeration value="HeaderRowDelimiter"/>
    <xs:enumeration value="ColumnNamesInFirstDataRow"/>
    <xs:enumeration value="RowDelimiter"/>
    <xs:enumeration value="DataRowsToSkip"/>
    <xs:enumeration value="TextQualifier"/>
    <xs:enumeration value="CodePage"/>
    <xs:enumeration value="ServerName"/>
    <xs:enumeration value="UseFile"/>
    <xs:enumeration value="UseEncryption"/>
    <xs:enumeration value="RetainData"/>
  </xs:restriction>
</xs:simpleType>

<xs:attributeGroup name="ConnectionManagerConnectionManagerAttributeGroup">
  <xs:attribute name="Retain" type="DTS:BooleanStringCap" default="False"
    use="optional" form="qualified"/>
  <xs:attribute name="ConnectionString" type="xs:string" use="required"
    form="qualified"/>
  <xs:attribute name="FileUsageType" type="DTS:FileUsageTypeEnum"
    default="0" use="optional" form="qualified"/>
  <xs:attribute name="Format" type="DTS:FormatEnum" use="optional"
    form="qualified"/>
  <xs:attribute name="LocaleID" type="xs:int" use="optional"
    form="qualified"/>
  <xs:attribute name="Unicode" type="DTS:BooleanStringCap" default="False"
    use="optional" form="qualified"/>
  <xs:attribute name="HeaderRowsToSkip" type="xs:int" default="0"

```



```

        use="optional" form="qualified"/>
<xs:attribute name="HeaderRowDelimiter" type="xs:string" use="optional"
    form="qualified"/>
<xs:attribute name="ColumnNamesInFirstDataRow" default="False"
    type="DTS:BooleanStringCap" use="optional" form="qualified"/>
<xs:attribute name="RowDelimiter" type="xs:string" use="optional"
    form="qualified"/>
<xs:attribute name="DataRowsToSkip" type="xs:int" default="0"
    use="optional" form="qualified"/>
<xs:attribute name="TextQualifier" type="xs:string" use="optional"
    form="qualified"/>
<xs:attribute name="CodePage" type="xs:int" use="optional"
    form="qualified"/>
<xs:attribute name="ServerName" type="xs:string" use="optional"
    form="qualified"/>
<xs:attribute name="UseFile" type="DTS:BooleanStringCap"
    default="False" use="optional" form="qualified"/>
<xs:attribute name="UseEncryption" type="DTS:BooleanStringCap"
    default="False" use="optional" form="qualified"/>
<xs:attribute name="RetainData" type="DTS:BooleanStringCap"
    default="True" use="optional" form="qualified"/>
</xs:attributeGroup>
<!--2 ENUM follow-->
<xs:simpleType name="FileUsageTypeEnum">
    <xs:restriction base="xs:int">
        <xs:minInclusive value="0"/>
        <xs:maxInclusive value="3"/>
    </xs:restriction>
</xs:simpleType>

<xs:simpleType name="FormatEnum">
    <xs:restriction base="xs:string">
        <xs:enumeration value="Delimited"/>
        <xs:enumeration value="FixedWidth"/>
        <xs:enumeration value="RaggedRight"/>
    </xs:restriction>
</xs:simpleType>

<xs:simpleType name="FlatFileColumnPropertyNameEnum">
    <xs:union memberTypes="DTS:BasePropertyNameEnum">
        <xs:simpleType>
            <xs:restriction base="xs:string">
                <xs:enumeration value="ColumnType"/>
                <xs:enumeration value="ColumnDelimiter"/>
                <xs:enumeration value="ColumnWidth"/>
                <xs:enumeration value="MaximumWidth"/>
                <xs:enumeration value="DataType"/>
                <xs:enumeration value="DataPrecision"/>
                <xs:enumeration value="DataScale"/>
                <xs:enumeration value="TextQualified"/>
            </xs:restriction>
        </xs:simpleType>
    </xs:union>
</xs:simpleType>

<xs:attributeGroup name="FlatFileColumnAttributeGroup">
    <xs:attribute name="ColumnType" type="DTS:ColumnTypeEnum"
        default="FixedWidth" use="optional" form="qualified"/>
    <xs:attribute name="ColumnDelimiter" type="xs:string"

```

```

        use="required" form="qualified"/>
<xs:attribute name="ColumnWidth" type="xs:int" default="0"
        use="optional" form="qualified"/>
<xs:attribute name="MaximumWidth" type="xs:int" default="0"
        use="optional" form="qualified"/>
<xs:attribute name="DataType" type="DTS:DtsDataTypeEnum" default="0"
        use="optional" form="qualified"/>
<xs:attribute name="DataPrecision" type="xs:int" default="0"
        use="optional" form="qualified"/>
<xs:attribute name="DataScale" type="xs:int" default="0" use="optional"
        form="qualified"/>
<xs:attribute name="TextQualified" type="DTS:BooleanStringCap"
        default="False" use="optional" form="qualified"/>
</xs:attributeGroup>
<!--1 ENUM follows-->
<xs:simpleType name="ColumnTypeEnum">
    <xs:restriction base="xs:string">
        <xs:enumeration value="Delimited"/>
        <xs:enumeration value="FixedWidth"/>
    </xs:restriction>
</xs:simpleType>

<xs:simpleType name="CacheColumnNameEnum">
    <xs:union memberTypes="DTS:BasePropertyNameEnum">
        <xs:simpleType>
            <xs:restriction base="xs:string">
                <xs:enumeration value="DataType"/>
                <xs:enumeration value="Length"/>
                <xs:enumeration value="Precision"/>
                <xs:enumeration value="Scale"/>
                <xs:enumeration value="CodePage"/>
                <xs:enumeration value="IndexPosition"/>
            </xs:restriction>
        </xs:simpleType>
    </xs:union>
</xs:simpleType>

<xs:attributeGroup name="CacheColumnAttributeGroup">
    <xs:attribute name="DataType" type="DTS:DtsDataTypeEnum" default="0"
        use="optional" form="qualified"/>
    <xs:attribute name="Length" type="xs:int" default="0" use="optional"
        form="qualified"/>
    <xs:attribute name="Precision" type="xs:int" default="0" use="optional"
        form="qualified"/>
    <xs:attribute name="Scale" type="xs:int" default="0" use="optional"
        form="qualified"/>
    <xs:attribute name="CodePage" type="xs:int" default="0" use="optional"
        form="qualified"/>
    <xs:attribute name="IndexPosition" type="xs:int" default="0"
        use="optional" form="qualified"/>
</xs:attributeGroup>
<!--0 ENUM-->

<xs:simpleType name="FtpConnectionPropertyNameEnum">
    <xs:restriction base="xs:string">
        <xs:enumeration value="ServerPassword"/>
    </xs:restriction>
</xs:simpleType>

```

```

<xs:attributeGroup name="FtpConnectionAttributeGroup">
  <xs:attribute name="ServerName" type="xs:string" use="required"
    form="qualified"/>
  <xs:attribute name="ServerPort" type="xs:int" default="21"
    use="optional" form="qualified"/>
  <xs:attribute name="ServerUserName" type="xs:string" default=""
    use="optional" form="qualified"/>
  <xs:attribute name="ChunkSize" type="xs:int" default="1" use="optional"
    form="qualified"/>
  <xs:attribute name="TimeOut" type="xs:int" default="60" use="optional"
    form="qualified"/>
  <xs:attribute name="Retries" type="xs:int" default="5" use="optional"
    form="qualified"/>
  <xs:attribute name="UsePassiveMode" type="DTS:BooleanStringCap"
    default="False" use="optional" form="qualified"/>
</xs:attributeGroup>
<!--0 ENUM-->

<xs:simpleType name="HttpConnectionPropertyNameEnum">
  <xs:restriction base="xs:string">
    <xs:enumeration value="ProxyPassword"/>
    <xs:enumeration value="ServerPassword"/>
  </xs:restriction>
</xs:simpleType>

<xs:attributeGroup name="HttpConnectionAttributeGroup">
  <xs:attribute name="ServerURL" type="xs:string" use="required"
    form="qualified"/>
  <xs:attribute name="UseServerCredentials" type="DTS:BooleanStringCap"
    default="False" use="optional" form="qualified"/>
  <xs:attribute name="ServerUserName" type="xs:string" default=""
    use="optional" form="qualified"/>
  <xs:attribute name="ServerDomain" type="xs:string" default=""
    use="optional" form="qualified"/>
  <xs:attribute name="UseSecureConnection" type="DTS:BooleanStringCap"
    default="False" use="optional" form="qualified"/>
  <xs:attribute name="CertificateIdentifier" type="xs:string" default=""
    use="optional" form="qualified"/>
  <xs:attribute name="Certificate" type="xs:string" default=""
    use="optional" form="qualified"/>
  <xs:attribute name="TimeOut" type="xs:int" default="60" use="optional"
    form="qualified"/>
  <xs:attribute name="ChunkSize" type="xs:int" default="1" use="optional"
    form="qualified"/>
  <xs:attribute name="UseProxy" type="DTS:BooleanStringCap"
    default="False" use="optional" form="qualified"/>
  <xs:attribute name="ProxyURL" type="xs:string" default="" use="optional"
    form="qualified"/>
  <xs:attribute name="BypassProxyOnLocal" type="DTS:BooleanStringCap"
    default="False" use="optional" form="qualified"/>
  <xs:attribute name="UseProxyCredentials" type="DTS:BooleanStringCap"
    default="False" use="optional" form="qualified"/>
  <xs:attribute name="ProxyUserName" type="xs:string" default=""
    use="optional" form="qualified"/>
  <xs:attribute name="ProxyDomain" type="xs:string" default=""
    use="optional" form="qualified"/>
  <xs:attribute name="BypassList" type="xs:string" default=""
    use="optional" form="qualified"/>
</xs:attributeGroup>

```

```

<xs:simpleType name="EventHandlerPropertyNameEnum">
  <xs:union memberTypes="DTS:BaseExecutablePropertyNameEnum">
    <xs:simpleType>
      <xs:restriction base="xs:string">
        <xs:enumeration value="EventID"/>
        <xs:enumeration value="EventName"/>
      </xs:restriction>
    </xs:simpleType>
  </xs:union>
</xs:simpleType>

<xs:attributeGroup name="EventHandlerAttributeGroup">
  <xs:attribute name="EventID" type="xs:int" use="optional"
    default="0" form="qualified"/>
  <xs:attribute name="EventName" type="DTS:EventNameEnum"
    use="required" form="qualified"/>
</xs:attributeGroup>

<xs:simpleType name="EventNameEnum">
  <xs:restriction base="xs:string">
    <xs:enumeration value="OnError"/>
    <xs:enumeration value="OnExecStatusChanged"/>
    <xs:enumeration value="OnInformation"/>
    <xs:enumeration value="OnPostExecute"/>
    <xs:enumeration value="OnPreExecute"/>
    <xs:enumeration value="OnPreValidate"/>
    <xs:enumeration value="OnProgress"/>
    <xs:enumeration value="OnQueryCancel"/>
    <xs:enumeration value="OnTaskFailed"/>
    <xs:enumeration value="OnVariableValueChanged"/>
    <xs:enumeration value="OnWarning"/>
    <xs:enumeration value="OnCustomEvent"/>
  </xs:restriction>
</xs:simpleType>

<xs:simpleType name="FileSystemTaskOperationTypeEnum">
  <xs:restriction base="xs:string">
    <xs:enumeration value="CopyFile" />
    <xs:enumeration value="CreateDirectory" />
    <xs:enumeration value="DeleteDirectory" />
    <xs:enumeration value="DeleteFile" />
    <xs:enumeration value="MoveDirectory" />
    <xs:enumeration value="MoveFile" />
    <xs:enumeration value="RenameFile" />
    <xs:enumeration value="SetAttributes" />
    <xs:enumeration value="DeleteDirectoryContent" />
    <xs:enumeration value="CopyDirectory" />
  </xs:restriction>
</xs:simpleType>

<xs:simpleType name="FileSystemTaskFileAttributesEnum">
  <xs:restriction base="xs:string">
    <xs:enumeration value="Archive" />
    <xs:enumeration value="Hidden" />
    <xs:enumeration value="Normal" />
    <xs:enumeration value="ReadOnly" />
    <xs:enumeration value="System" />
  </xs:restriction>
</xs:simpleType>

```

```

</xs:simpleType>

<xs:simpleType name="SourceTypeEnum">
  <xs:restriction base="xs:string">
    <xs:enumeration value="DirectInput"/>
    <xs:enumeration value="FileConnection"/>
    <xs:enumeration value="Variable"/>
  </xs:restriction>
</xs:simpleType>

<!--Other Misc Types-->

<xs:simpleType name="uuid">
  <xs:restriction base="xs:string">
    <xs:pattern value="\{[0-9a-zA-Z]{8}-[0-9a-zA-Z]{4}-[0-9a-zA-Z]{4}-[0-9a-zA-Z]{4}-[0-9a-zA-Z]{12}\}" />
    <xs:pattern value=""/>
  </xs:restriction>
</xs:simpleType>

</xs:schema>

```

5.2 WebServiceTask XSD

```

<?xml version="1.0" encoding="utf-8"?>
<xs:schema xmlns:WSTask="www.microsoft.com/sqlserver/dts/tasks/webservicetask"
  xmlns:xs="http://www.w3.org/2001/XMLSchema"
  targetNamespace="www.microsoft.com/sqlserver/dts/tasks/webservicetask"
  elementFormDefault="qualified"
  attributeFormDefault="qualified"
  >

  <xs:element name="WebServiceTaskData"
    type="WSTask:WSTaskDataType"/>

  <xs:complexType name="WSTaskDataType">
    <xs:sequence>
      <xs:element name="MethodInfo"
        type="WSTask:WebServiceTaskDataMethodInfoType"/>
    </xs:sequence>
    <xs:attribute name="ConnectionName" type="xs:string" use="optional"
      default=""/>
    <xs:attribute name="Service" type="xs:string" use="optional"
      default=""/>
    <xs:attribute name="WSDLFile" type="xs:string" use="optional"
      default=""/>
    <xs:attribute name="OverwriteWSDLFile" use="optional" default="False">
      <xs:simpleType>
        <xs:restriction base="xs:string">
          <xs:enumeration value="True"/>
          <xs:enumeration value="False"/>
        </xs:restriction>
      </xs:simpleType>
    </xs:attribute>
    <xs:attribute name="OutputType"
      type="WSTask:WebServiceTaskDataOutputTypeEnum"
      use="optional" default="File"/>
  </xs:complexType>

```

```

        <xs:attribute name="OutputLocation" type="xs:string" use="optional"
            default=""/>
    </xs:complexType>

    <xs:complexType name="WebServiceTaskDataMethodInfoType">
        <xs:sequence>
            <xs:element name="Documentation" type="xs:string"
                minOccurs="0" maxOccurs="1"/>
            <xs:element name="ParamInfo"
                type="WSTask:WebServiceTaskDataParamInfoType"
                maxOccurs="unbounded"/>
        </xs:sequence>
        <xs:attribute name="MethodName" type="xs:string"/>
        <xs:attribute name="MessageName" type="xs:string"/>
    </xs:complexType>

    <xs:complexType name="WebServiceTaskDataParamInfoType">
        <xs:sequence>
            <xs:element name="VariableValue" type="xs:string"
                minOccurs="0" maxOccurs="1"/>
            <xs:element name="PrimitiveValue" type="xs:anySimpleType"
                minOccurs="0" maxOccurs="1"/>
        </xs:sequence>
        <xs:attribute name="Name" type="xs:string"/>
        <xs:attribute name="Datatype" type="xs:string"/>
        <xs:attribute name="ParamType" type="WSTask:ParamTypeEnum"/>
        <xs:attribute name="SeqNumber" type="xs:int"/>
    </xs:complexType>

    <xs:simpleType name="WebServiceTaskDataOutputTypeEnum">
        <xs:restriction base="xs:string">
            <xs:enumeration value="File"/>
            <xs:enumeration value="Variable"/>
        </xs:restriction>
    </xs:simpleType>

    <xs:simpleType name="ParamTypeEnum">
        <xs:restriction base="xs:string">
            <xs:enumeration value="Variable"/>
            <xs:enumeration value="Primitive"/>
        </xs:restriction>
    </xs:simpleType>

</xs:schema>

```

5.3 MessageQueueTask XSD

```

<?xml version="1.0" encoding="utf-8"?>
<xs:schema xmlns:MessageQueueTask="www.microsoft.com/sqlserver/dts/tasks/messagequeuetask"
    xmlns:xs="http://www.w3.org/2001/XMLSchema"
    targetNamespace="www.microsoft.com/sqlserver/dts/tasks/messagequeuetask"
    elementFormDefault="qualified"
    attributeFormDefault="qualified"
    xmlns:DTS="www.microsoft.com/SqlServer/Dts"
    >

    <xs:import namespace="www.microsoft.com/SqlServer/Dts"

```

```

    schemaLocation="./DTSX2.xsd" />

<xs:element name="MessageQueueTaskData"
    type="MessageQueueTask:MessageQueueTaskType"/>

<xs:complexType name="MessageQueueTaskType">
  <xs:sequence>
  </xs:sequence>
  <xs:attribute name="CurrentPackageID" type="DTS:uuid" use="optional"
    default=""/>
  <xs:attribute name="TaskDescription" type="xs:string" use="optional"
    default=""/>
  <xs:attribute name="DataFileOverWritable" use="optional"
    default="False">
    <xs:simpleType>
      <xs:restriction base="xs:string">
        <xs:enumeration value="False"/>
        <xs:enumeration value="True"/>
      </xs:restriction>
    </xs:simpleType>
  </xs:attribute>
  <xs:attribute name="DTSMessageLineageID" type="xs:string" use="optional"
    default=""/>
  <xs:attribute name="DTSMessagePackageID" type="xs:string" use="optional"
    default=""/>
  <xs:attribute name="DTSMessageVersionID" type="xs:string" use="optional"
    default=""/>
  <xs:attribute name="ErrorIfMessageTimeOut" use="optional"
    default="False">
    <xs:simpleType>
      <xs:restriction base="xs:string">
        <xs:enumeration value="False"/>
        <xs:enumeration value="True"/>
      </xs:restriction>
    </xs:simpleType>
  </xs:attribute>
  <xs:attribute name="QueuePath" type="xs:string"/>
  <xs:attribute name="ReceiveMessageTimeOut" type="xs:int" use="optional"
    default="0"/>
  <xs:attribute name="ReceiveMessageType"
    type="MessageQueueTask:MSMQMessageTypeEnum"
    use="optional" default="DTSMQMessageType_String"/>
  <xs:attribute name="RemoveFromQueue" use="optional" default="False">
    <xs:simpleType>
      <xs:restriction base="xs:string">
        <xs:enumeration value="False"/>
        <xs:enumeration value="True"/>
      </xs:restriction>
    </xs:simpleType>
  </xs:attribute>
  <xs:attribute name="SaveDataFileName" type="xs:string" use="optional"
    default=""/>
  <xs:attribute name="StringCompareType"
    type="MessageQueueTask:MSMQStringCompareTypeEnum"
    use="optional" default="DTSMQStringMessageCompare_None"/>
  <xs:attribute name="StringCompareValue" type="xs:string" use="optional"
    default=""/>
  <xs:attribute name="StringMessageToVariableName" type="xs:string"
    use="optional" default=""/>

```

```

<xs:attribute name="ReceiveVariableMessage" type="xs:string"
  use="optional" default=""/>
<xs:attribute name="TaskType"
  type="MessageQueueTask:MSMQTaskTypeEnum"
  use="optional" default="DTSMQType_Sender"/>
<xs:attribute name="UseEncryption" use="optional" default="False">
  <xs:simpleType>
    <xs:restriction base="xs:string">
      <xs:enumeration value="False"/>
      <xs:enumeration value="True"/>
    </xs:restriction>
  </xs:simpleType>
</xs:attribute>
<xs:attribute name="EncryptionAlgorithm"
  type="MessageQueueTask:MSMQEncryptionAlgorithmEnum"
  use="optional" default="Rc2"/>
<xs:attribute name="Use2000Format" use="optional" default="False">
  <xs:simpleType>
    <xs:restriction base="xs:string">
      <xs:enumeration value="False"/>
      <xs:enumeration value="True"/>
    </xs:restriction>
  </xs:simpleType>
</xs:attribute>
<xs:attribute name="DataFileName" type="xs:string" use="optional"
  default=""/>
<xs:attribute name="StringMessage" type="xs:string" use="optional"
  default=""/>
<xs:attribute name="VariableMessage" type="xs:string" use="optional"
  default=""/>
<xs:attribute name="MessageType"
  type="MessageQueueTask:MSMQMessageTypeEnum"
  use="optional" default="DTSMQMessageType_String"/>
</xs:complexType>

<xs:simpleType name="MSMQStringCompareTypeEnum">
  <xs:restriction base="xs:string">
    <xs:enumeration value="DTSMQStringMessageCompare_Contains"/>
    <xs:enumeration value="DTSMQStringMessageCompare_Exact"/>
    <xs:enumeration value="DTSMQStringMessageCompare_IgnoreCase"/>
    <xs:enumeration value="DTSMQStringMessageCompare_None"/>
  </xs:restriction>
</xs:simpleType>

<xs:simpleType name="MSMQTaskTypeEnum">
  <xs:restriction base="xs:string">
    <xs:enumeration value="DTSMQType_Receiver"/>
    <xs:enumeration value="DTSMQType_Sender"/>
  </xs:restriction>
</xs:simpleType>

<xs:simpleType name="MSMQMessageTypeEnum">
  <xs:restriction base="xs:string">
    <xs:enumeration value="DTSMQMessageToVariable_StringMessageToVariable"/>
    <xs:enumeration value="DTSMQMessageType_DataFile"/>
    <xs:enumeration value="DTSMQMessageType_String"/>
    <xs:enumeration value="DTSMQMessageType_Variables"/>
  </xs:restriction>
</xs:simpleType>

```



```

<xs:simpleType name="MSMQEncryptionAlgorithmEnum">
  <xs:restriction base="xs:string">
    <xs:enumeration value="Rc2"/>
    <xs:enumeration value="Rc4"/>
  </xs:restriction>
</xs:simpleType>

</xs:schema>

```

5.4 SendMailTask XSD

```

<?xml version="1.0" encoding="utf-8"?>
<xs:schema
  xmlns:SendMailTask="www.microsoft.com/sqlserver/dts/tasks/sendmailtask"
  xmlns:xs="http://www.w3.org/2001/XMLSchema"
  targetNamespace="www.microsoft.com/sqlserver/dts/tasks/sendmailtask"
  elementFormDefault="qualified"
  attributeFormDefault="qualified"
  xmlns:DTS="www.microsoft.com/SqlServer/Dts"
  >

  <xs:import namespace="www.microsoft.com/SqlServer/Dts"
    schemaLocation="./DTSX2.xsd" />

  <xs:element name="SendMailTaskData"
    type="SendMailTask:SendMailTaskType"/>

  <xs:complexType name="SendMailTaskType">
    <xs:sequence>
      <xs:element name="Attachments" minOccurs="0"
        type="SendMailTask:AttachmentsElementType"/>
    </xs:sequence>
    <xs:attribute name="SMTPServer" type="xs:string" use="optional"
      default=""/>
    <xs:attribute name="From" type="xs:string" use="optional" default=""/>
    <xs:attribute name="To" type="xs:string" use="optional" default=""/>
    <xs:attribute name="CC" type="xs:string" use="optional" default=""/>
    <xs:attribute name="BCC" type="xs:string" use="optional" default=""/>
    <xs:attribute name="Subject" type="xs:string" use="optional"
      default=""/>
    <xs:attribute name="Priority"
      type="SendMailTask:SendMailPriorityEnum"
      use="optional" default="Normal"/>
    <xs:attribute name="MessageSourceType"
      type="DTS:SourceTypeEnum"/>
    <xs:attribute name="MessageSource" type="xs:string"
      use="optional" default="DirectInput"/>
  </xs:complexType>

  <xs:simpleType name="SendMailPriorityEnum">
    <xs:restriction base="xs:string">
      <xs:enumeration value="High"/>
      <xs:enumeration value="Low"/>
      <xs:enumeration value="Normal"/>
    </xs:restriction>
  </xs:simpleType>

```

```

    </xs:restriction>
  </xs:simpleType>

  <xs:complexType name="AttachmentsElementType">
    <xs:sequence/>
    <xs:attribute name="FileName" type="xs:string"/>
  </xs:complexType>

</xs:schema>

```

5.5 ActiveXScriptTask XSD

```

<?xml version="1.0" encoding="utf-8"?>
<xs:schema xmlns:ActiveXScriptTask="www.microsoft.com/sqlserver/dts/tasks/activexscripttask"
  xmlns:xs="http://www.w3.org/2001/XMLSchema"
  targetNamespace="www.microsoft.com/sqlserver/dts/tasks/activexscripttask"
  elementFormDefault="qualified"
  attributeFormDefault="qualified"
  >

  <xs:element name="ActiveXScriptTaskData"
    type="ActiveXScriptTask:ActiveXScriptTaskDataType"/>

  <xs:complexType name="ActiveXScriptTaskDataType">
    <xs:sequence/>
    <xs:attribute name="ScriptingLanguage"
      type="ActiveXScriptTask:ScriptingLanguageEnum"/>
    <xs:attribute name="ScriptText" type="xs:string"/>
    <xs:attribute name="EntryMethod" type="xs:string"/>
  </xs:complexType>

  <xs:simpleType name="ScriptingLanguageEnum">
    <xs:restriction base="xs:string">
      <xs:enumeration value="VBScript"/>
      <xs:enumeration value="JScript.Compact"/>
      <xs:enumeration value="JScript"/>
    </xs:restriction>
  </xs:simpleType>

</xs:schema>

```

5.6 Exec80PackageTask XSD

```

<?xml version="1.0" encoding="utf-8"?>
<xs:schema xmlns:Exec80PackageTask="www.microsoft.com/sqlserver/dts/tasks/exec80packagetask"
  xmlns:xs="http://www.w3.org/2001/XMLSchema"
  targetNamespace="www.microsoft.com/sqlserver/dts/tasks/exec80packagetask"
  elementFormDefault="qualified"
  attributeFormDefault="qualified"
  xmlns:DTS="www.microsoft.com/SqlServer/Dts"
  >
  <xs:import namespace="www.microsoft.com/SqlServer/Dts"
    schemaLocation="./DTSX2.xsd" />

```

```

<xs:element name="Exec80PackageTaskData"
            type="Exec80PackageTask:Exec80PackageTaskType"/>

<xs:complexType name="Exec80PackageTaskType">
  <xs:sequence>
    <xs:element name="DTS2000Package" type="xs:base64Binary"
                minOccurs="0" form="unqualified"/>
  </xs:sequence>
  <xs:attribute name="Location"
                type="Exec80PackageTask:Exec80PackageTaskLocationEnum"/>
  <xs:attribute name="PackageName" type="xs:string"/>
  <xs:attribute name="PackageID" type="DTS:uuid"/>
  <xs:attribute name="PackageVersionGUID" type="DTS:uuid"/>
  <xs:attribute name="SQLServer" type="xs:string"/>
  <xs:attribute name="SQLUsername" type="xs:string"/>
  <xs:attribute name="WindowsAuthentication">
    <xs:simpleType>
      <xs:restriction base="xs:string">
        <xs:enumeration value="True"/>
        <xs:enumeration value="False"/>
      </xs:restriction>
    </xs:simpleType>
  </xs:attribute>
  <xs:attribute name="Filename" type="xs:string"/>
  <xs:attribute name="InnerGlobalVariables" type="xs:string"/>
  <xs:attribute name="OuterGlobalVariables" type="xs:string"/>
</xs:complexType>

<xs:simpleType name="Exec80PackageTaskLocationEnum">
  <xs:restriction base="xs:string">
    <xs:enumeration value="SqlServer"/>
    <xs:enumeration value="EmbeddedInTask"/>
    <xs:enumeration value="StorageFile"/>
  </xs:restriction>
</xs:simpleType>

</xs:schema>

```

5.7 BulkInsertTask XSD

```

<?xml version="1.0" encoding="utf-8"?>
<xs:schema xmlns:BulkInsertTask="www.microsoft.com/sqlserver/dts/tasks/bulkinserttask"
            xmlns:xs="http://www.w3.org/2001/XMLSchema"
            targetNamespace="www.microsoft.com/sqlserver/dts/tasks/bulkinserttask"
            elementFormDefault="qualified"
            attributeFormDefault="qualified"
            >

  <xs:element name="BulkInsertTaskData"
            type="BulkInsertTask:BulkInsertTaskDataType"/>

  <xs:complexType name="BulkInsertTaskDataType">
    <xs:sequence/>
    <xs:attribute name="BatchSize" type="xs:int" use="optional"
                  default="0"/>
    <xs:attribute name="CheckConstraints" use="optional" default="True">
      <xs:simpleType>

```

```

        <xs:restriction base="xs:string">
            <xs:enumeration value="True"/>
            <xs:enumeration value="False"/>
        </xs:restriction>
    </xs:simpleType>
</xs:attribute>
<xs:attribute name="CodePage" type="BulkInsertTask:CodePageType"
    use="optional" default="RAW"/>
<xs:attribute name="SourceConnectionName" type="xs:string"
    use="optional" default=""/>
<xs:attribute name="DestinationConnectionName" type="xs:string"
    use="optional" default=""/>
<xs:attribute name="DataFileType"
    type="BulkInsertTask:DataFileTypeEnum"
    use="optional" default="DTSBulkInsert_DataFileType_Char"/>
<xs:attribute name="DestinationTableName" type="xs:string"
    use="optional" default=""/>
<xs:attribute name="FirstRow" type="xs:int" use="optional"
    default="1"/>
<xs:attribute name="LastRow" type="xs:int" use="optional"
    default="0"/>
<xs:attribute name="UseFormatFile" use="optional" default="False">
<xs:simpleType>
    <xs:restriction base="xs:string">
        <xs:enumeration value="True"/>
        <xs:enumeration value="False"/>
    </xs:restriction>
</xs:simpleType>
</xs:attribute>
<xs:attribute name="FormatFile" type="xs:string" use="optional"
    default=""/>
<xs:attribute name="SortedData" type="xs:string" use="optional"
    default=""/>
<xs:attribute name="TableLock" use="optional" default="False">
<xs:simpleType>
    <xs:restriction base="xs:string">
        <xs:enumeration value="True"/>
        <xs:enumeration value="False"/>
    </xs:restriction>
</xs:simpleType>
</xs:attribute>
<xs:attribute name="KeepIdentity" use="optional" default="False">
<xs:simpleType>
    <xs:restriction base="xs:string">
        <xs:enumeration value="True"/>
        <xs:enumeration value="False"/>
    </xs:restriction>
</xs:simpleType>
</xs:attribute>
<xs:attribute name="KeepNulls" use="optional" default="False">
<xs:simpleType>
    <xs:restriction base="xs:string">
        <xs:enumeration value="True"/>
        <xs:enumeration value="False"/>
    </xs:restriction>
</xs:simpleType>
</xs:attribute>
<xs:attribute name="FieldTerminator"
    type="BulkInsertTask:BulkInsertTaskTerminatorEnum"

```

```

        use="optional" default="Tab"/>
<xs:attribute name="RowTerminator"
    type="BulkInsertTask:BulkInsertTaskTerminatorEnum"
    use="optional" default="{CR}{LF}"/>
<xs:attribute name="FireTriggers" use="optional" default="False">
  <xs:simpleType>
    <xs:restriction base="xs:string">
      <xs:enumeration value="True"/>
      <xs:enumeration value="False"/>
    </xs:restriction>
  </xs:simpleType>
</xs:attribute>
<xs:attribute name="MaximumErrors" type="xs:int" use="optional"
    default="0"/>
</xs:complexType>

<xs:simpleType name="DataFileTypeEnum">
  <xs:restriction base="xs:string">
    <xs:enumeration value="DTSBulkInsert_DataFileType_Char"/>
    <xs:enumeration value="DTSBulkInsert_DataFileType_Native"/>
    <xs:enumeration value="DTSBulkInsert_DataFileType_WideChar"/>
    <xs:enumeration value="DTSBulkInsert_DataFileType_WideNative"/>
  </xs:restriction>
</xs:simpleType>

<xs:simpleType name="CodePageType">
  <xs:union memberTypes="xs:int">
    <xs:simpleType>
      <xs:restriction base="xs:string">
        <xs:enumeration value="ACP"/>
        <xs:enumeration value="OEM"/>
        <xs:enumeration value="RAW"/>
      </xs:restriction>
    </xs:simpleType>
  </xs:union>
</xs:simpleType>

<xs:simpleType name="BulkInsertTaskTerminatorEnum">
  <xs:restriction base="xs:string">
    <xs:enumeration value="{CR}{LF}"/>
    <xs:enumeration value="{CR}"/>
    <xs:enumeration value="{LF}"/>
    <xs:enumeration value="Semicolon {;}"/>
    <xs:enumeration value="Comma {,}"/>
    <xs:enumeration value="Tab"/>
    <xs:enumeration value="Vertical Bar {|}"/>
  </xs:restriction>
</xs:simpleType>
</xs:schema>

```

5.8 SQLTask XSD

```

<?xml version="1.0" encoding="utf-8"?>
<xs:schema xmlns:SQLTask="www.microsoft.com/sqlserver/dts/tasks/sqltask"
    xmlns:xs="http://www.w3.org/2001/XMLSchema"
    targetNamespace="www.microsoft.com/sqlserver/dts/tasks/sqltask"
    elementFormDefault="qualified"

```

```

        attributeFormDefault="qualified"
        xmlns:DTS="www.microsoft.com/SqlServer/Dts"
    >

<xs:import namespace="www.microsoft.com/SqlServer/Dts"
    schemaLocation="./DTSX2.xsd" />

<xs:element name="SqlTaskData"
    type="SQLTask:SqlTaskDataElementBackupTaskType"/>

<xs:complexType name="SqlTaskDataType">
    <xs:sequence>
        <xs:element name="SelectedDatabases"
            type="SQLTask:SelectedDatabasesType"
            minOccurs="0" maxOccurs="unbounded"/>
        <xs:element name="OperatorNotifyList"
            type="SQLTask:OperatorNotifyListType"
            minOccurs="0" maxOccurs="unbounded"/>
        <xs:element name="ParameterBinding"
            type="SQLTask:SqlTaskParameterBindingType"
            minOccurs="0" maxOccurs="unbounded"/>
        <xs:element name="ResultBinding"
            type="SQLTask:SqlTaskResultBindingType"
            minOccurs="0" maxOccurs="1"/>
        <xs:element name="BackupDestinationList"
            type="SQLTask:BackupDestinationListType"
            minOccurs="0" maxOccurs="unbounded"/>
    </xs:sequence>
    <xs:attributeGroup
        ref="SQLTask:SqlTaskBaseAttributeGroup"/>
    <xs:attributeGroup
        ref="SQLTask:MaintenanceTaskBaseAttributeGroup"/>
    <xs:attributeGroup
        ref="SQLTask:BackupTaskAttributeGroup"/>
    <xs:attributeGroup
        ref="SQLTask:CheckIntegrityTaskAttributeGroup"/>
    <xs:attributeGroup
        ref="SQLTask:AgentJobTaskAttributeGroup"/>
    <xs:attributeGroup
        ref="SQLTask:HistoryCleanupTaskAttributeGroup"/>
    <xs:attributeGroup
        ref="SQLTask:MaintenanceFileCleanupTaskAttributeGroup"/>
    <xs:attributeGroup
        ref="SQLTask:NotifyOperatorTaskAttributeGroup"/>
    <xs:attributeGroup
        ref="SQLTask:RebuildIndexTaskAttributeGroup"/>
    <xs:attributeGroup
        ref="SQLTask:ReorganizeIndexTaskAttributeGroup"/>
    <xs:attributeGroup
        ref="SQLTask:ShrinkDBTaskAttributeGroup"/>
    <xs:attributeGroup
        ref="SQLTask:UpdateStatisticsTaskAttributeGroup"/>
    <xs:attributeGroup
        ref="SQLTask:TSQLExecuteTaskAttributeGroup"/>
    <xs:attribute name="RemoveOlderThan" type="xs:int"/>
    <xs:attribute name="TimeUnitsType"
        type="SQLTask:SqlTaskTimeUnitsTypeEnum"/>
    <xs:attribute name="DatabaseSelectionType"
        type="SQLTask:SqlTaskDatabaseSelectionTypeEnum"/>

```

```

</xs:complexType>

<xs:simpleType name="SqlResultTypeEnum">
  <xs:restriction base="xs:string">
    <xs:enumeration value="ResultSetType_None"/>
    <xs:enumeration value="ResultSetType_Rowset"/>
    <xs:enumeration value="ResultSetType_SingleRow"/>
    <xs:enumeration value="ResultSetType_XML"/>
  </xs:restriction>
</xs:simpleType>

<xs:complexType name="SelectedDatabasesType">
  <xs:sequence/>
  <xs:attribute name="DatabaseName" type="xs:string"/>
</xs:complexType>

<xs:complexType name="OperatorNotifyListType">
  <xs:sequence/>
  <xs:attribute name="OperatorNotify" type="xs:string"/>
</xs:complexType>

<xs:complexType name="SqlTaskParameterBindingType">
  <xs:sequence/>
  <xs:attribute name="ParameterName" type="xs:string"/>
  <xs:attribute name="DtsVariableName" type="xs:string"/>
  <xs:attribute name="ParameterDirection"
    type="SQLTask:ParameterDirectionEnum"/>
  <xs:attribute name="DataType" type="DTS:DtsDataTypeEnum"/>
  <xs:attribute name="ParameterSize" type="xs:int"/>
</xs:complexType>

<xs:simpleType name="ParameterDirectionEnum">
  <xs:restriction base="xs:string">
    <xs:enumeration value="Input"/>
    <xs:enumeration value="Output"/>
    <xs:enumeration value="ReturnValue"/>
  </xs:restriction>
</xs:simpleType>

<xs:complexType name="SqlTaskResultBindingType">
  <xs:sequence/>
  <xs:attribute name="ResultName" type="xs:string"/>
  <xs:attribute name="DtsVariableName" type="xs:string"/>
</xs:complexType>

<xs:complexType name="BackupDestinationListType">
  <xs:sequence/>
  <xs:attribute name="BackupDestinationLocation"
    type="xs:string"/>
</xs:complexType>

<!--Attribute Groups-->

<xs:attributeGroup name="SqlTaskBaseAttributeGroup">
  <xs:attribute name="Connection" type="DTS:uuid" use="optional"
    default=""/>
  <xs:attribute name="TimeOut" type="xs:int" use="optional" default="0"/>
  <xs:attribute name="IsStoredProc" use="optional" default="False">

```

```

    <xs:simpleType>
      <xs:restriction base="xs:string">
        <xs:enumeration value="True"/>
        <xs:enumeration value="False"/>
      </xs:restriction>
    </xs:simpleType>
  </xs:attribute>
  <xs:attribute name="BypassPrepare" use="optional" default="True">
    <xs:simpleType>
      <xs:restriction base="xs:string">
        <xs:enumeration value="True"/>
        <xs:enumeration value="False"/>
      </xs:restriction>
    </xs:simpleType>
  </xs:attribute>
  <xs:attribute name="SqlStmtSourceType"
    type="DTS:SourceTypeEnum"
    use="optional" default="DirectInput"/>
  <xs:attribute name="SqlStatementSource" type="xs:string"
    use="optional" default=""/>
  <xs:attribute name="CodePage" type="xs:int" use="optional"/>
  <xs:attribute name="ResultType"
    type="SQLTask:SqlResultTypeEnum"
    use="optional" default="ResultSetType_None"/>
</xs:attributeGroup>

<xs:attributeGroup name="MaintenanceTaskBaseAttributeGroup">
  <xs:attribute name="ServerVersion" type="xs:int"/>
  <xs:attribute name="ExtendedLogging">
    <xs:simpleType>
      <xs:restriction base="xs:string">
        <xs:enumeration value="True"/>
        <xs:enumeration value="False"/>
      </xs:restriction>
    </xs:simpleType>
  </xs:attribute>
  <xs:attribute name="LocalConnectionForLogging" type="xs:string"/>
  <xs:attribute name="TaskName" type="xs:string"/>
  <xs:attribute name="IgnoreDatabasesInNotOnlineState">
    <xs:simpleType>
      <xs:restriction base="xs:string">
        <xs:enumeration value="True"/>
        <xs:enumeration value="False"/>
      </xs:restriction>
    </xs:simpleType>
  </xs:attribute>
</xs:attributeGroup>

<xs:attributeGroup name="BackupTaskAttributeGroup">
  <xs:attribute name="BackupAction" type="SQLTask:BackupActionEnum"/>
  <xs:attribute name="BackupIsIncremental">
    <xs:simpleType>
      <xs:restriction base="xs:string">
        <xs:enumeration value="True"/>
        <xs:enumeration value="False"/>
      </xs:restriction>
    </xs:simpleType>
  </xs:attribute>
  <xs:attribute name="BackupFileGroupsFiles" type="xs:string"/>

```



```

<xs:attribute name="BackupDeviceType"
              type="SQLTask:BackupDeviceTypeEnum"/>
<xs:attribute name="BackupPhysicalDestinationType"
              type="SQLTask:BackupDeviceTypeEnum"/>
<xs:attribute name="BackupDestinationType"
              type="SQLTask:DestinationTypeEnum"/>
<xs:attribute name="BackupDestinationAutoFolderPath"
              type="xs:string"/>
<xs:attribute name="BackupActionForExistingBackups"
              type="SQLTask:BackupActionForExistingBackupsEnum"/>
<xs:attribute name="BackupCreateSubFolder">
  <xs:simpleType>
    <xs:restriction base="xs:string">
      <xs:enumeration value="True"/>
      <xs:enumeration value="False"/>
    </xs:restriction>
  </xs:simpleType>
</xs:attribute>
<xs:attribute name="BackupFileExtension" type="xs:string"/>
<xs:attribute name="BackupVerifyIntegrity">
  <xs:simpleType>
    <xs:restriction base="xs:string">
      <xs:enumeration value="True"/>
      <xs:enumeration value="False"/>
    </xs:restriction>
  </xs:simpleType>
</xs:attribute>
<xs:attribute name="ExpireDate" type="xs:dateTime"/>
<xs:attribute name="RetainDays" type="xs:int"/>
<xs:attribute name="InDays">
  <xs:simpleType>
    <xs:restriction base="xs:string">
      <xs:enumeration value="True"/>
      <xs:enumeration value="False"/>
    </xs:restriction>
  </xs:simpleType>
</xs:attribute>
<xs:attribute name="UseExpiration">
  <xs:simpleType>
    <xs:restriction base="xs:string">
      <xs:enumeration value="True"/>
      <xs:enumeration value="False"/>
    </xs:restriction>
  </xs:simpleType>
</xs:attribute>
<xs:attribute name="BackupCompressionAction"
              type="SQLTask:BackupCompressionActionEnum"/>
<xs:attribute name="BackupTailLog">
  <xs:simpleType>
    <xs:restriction base="xs:string">
      <xs:enumeration value="True"/>
      <xs:enumeration value="False"/>
    </xs:restriction>
  </xs:simpleType>
</xs:attribute>
</xs:attributeGroup>

<xs:simpleType name="BackupActionEnum">
  <xs:restriction base="xs:int">

```

```

        <xs:minInclusive value="0"/>
        <xs:maxInclusive value="2"/>
    </xs:restriction>
</xs:simpleType>

<xs:simpleType name="BackupDeviceTypeEnum">
    <xs:restriction base="xs:int">
        <xs:minInclusive value="0"/>
        <xs:maxInclusive value="4"/>
    </xs:restriction>
</xs:simpleType>

<xs:simpleType name="DestinationTypeEnum">
    <xs:restriction base="xs:int">
        <xs:minInclusive value="0"/>
        <xs:maxInclusive value="1"/>
    </xs:restriction>
</xs:simpleType>

<xs:simpleType name="BackupActionForExistingBackupsEnum">
    <xs:restriction base="xs:int">
        <xs:minInclusive value="0"/>
        <xs:maxInclusive value="1"/>
    </xs:restriction>
</xs:simpleType>

<xs:simpleType name="BackupCompressionActionEnum">
    <xs:restriction base="xs:int">
        <xs:minInclusive value="0"/>
        <xs:maxInclusive value="2"/>
    </xs:restriction>
</xs:simpleType>

<xs:attributeGroup name="CheckIntegrityTaskAttributeGroup">
    <xs:attribute name="IncludeIndexes">
        <xs:simpleType>
            <xs:restriction base="xs:string">
                <xs:enumeration value="True"/>
                <xs:enumeration value="False"/>
            </xs:restriction>
        </xs:simpleType>
    </xs:attribute>
</xs:attributeGroup>

<xs:simpleType name="SqlTaskDatabaseSelectionTypeEnum">
    <xs:restriction base="xs:int">
        <xs:minInclusive value="1"/>
        <xs:maxInclusive value="4"/>
    </xs:restriction>
</xs:simpleType>

<xs:attributeGroup name="AgentJobTaskAttributeGroup">
    <xs:attribute name="AgentJobID" type="xs:string"/>
</xs:attributeGroup>

<xs:attributeGroup name="HistoryCleanupTaskAttributeGroup">
    <xs:attribute name="RemoveBackupRestoreHistory">
        <xs:simpleType>
            <xs:restriction base="xs:string">

```

```

        <xs:enumeration value="True"/>
        <xs:enumeration value="False"/>
    </xs:restriction>
</xs:simpleType>
</xs:attribute>
<xs:attribute name="RemoveAgentHistory">
    <xs:simpleType>
        <xs:restriction base="xs:string">
            <xs:enumeration value="True"/>
            <xs:enumeration value="False"/>
        </xs:restriction>
    </xs:simpleType>
</xs:attribute>
<xs:attribute name="RemoveDbMaintHistory">
    <xs:simpleType>
        <xs:restriction base="xs:string">
            <xs:enumeration value="True"/>
            <xs:enumeration value="False"/>
        </xs:restriction>
    </xs:simpleType>
</xs:attribute>
</xs:attributeGroup>

<xs:simpleType name="SqlTaskTimeUnitsTypeEnum">
    <xs:restriction base="xs:int">
        <xs:enumeration value="0"/>
        <xs:enumeration value="1"/>
        <xs:enumeration value="2"/>
        <xs:enumeration value="3"/>
        <xs:enumeration value="5"/>
    </xs:restriction>
</xs:simpleType>

<xs:attributeGroup name="MaintenanceFileCleanupTaskAttributeGroup">
    <xs:attribute name="FileTypeSelected" type="xs:string"/>
    <xs:attribute name="FilePath" type="xs:string"/>
    <xs:attribute name="FolderPath" type="xs:string"/>
    <xs:attribute name="CleanSubFolders">
        <xs:simpleType>
            <xs:restriction base="xs:string">
                <xs:enumeration value="True"/>
                <xs:enumeration value="False"/>
            </xs:restriction>
        </xs:simpleType>
    </xs:attribute>
    <xs:attribute name="FileExtension" type="xs:string"/>
    <xs:attribute name="AgeBased">
        <xs:simpleType>
            <xs:restriction base="xs:string">
                <xs:enumeration value="True"/>
                <xs:enumeration value="False"/>
            </xs:restriction>
        </xs:simpleType>
    </xs:attribute>
    <xs:attribute name="DeleteSpecificFile">
        <xs:simpleType>
            <xs:restriction base="xs:string">
                <xs:enumeration value="True"/>
                <xs:enumeration value="False"/>
            </xs:restriction>
        </xs:simpleType>
    </xs:attribute>
</xs:attributeGroup>

```

```

        </xs:restriction>
    </xs:simpleType>
</xs:attribute>
</xs:attributeGroup>

<xs:simpleType name="SqlTaskFileTypeSelectedEnum">
    <xs:restriction base="xs:int">
        <xs:minInclusive value="0"/>
        <xs:maxInclusive value="1"/>
    </xs:restriction>
</xs:simpleType>

<xs:attributeGroup name="NotifyOperatorTaskAttributeGroup">
    <xs:attribute name="Message" type="xs:string"/>
    <xs:attribute name="Profile" type="xs:string"/>
    <xs:attribute name="Subject" type="xs:string"/>
</xs:attributeGroup>

<xs:attributeGroup name="RebuildIndexTaskAttributeGroup">
    <xs:attribute name="UseOriginalAmount">
        <xs:simpleType>
            <xs:restriction base="xs:string">
                <xs:enumeration value="True"/>
                <xs:enumeration value="False"/>
            </xs:restriction>
        </xs:simpleType>
    </xs:attribute>
    <xs:attribute name="Percentage" type="xs:int"/>
    <xs:attribute name="Sort">
        <xs:simpleType>
            <xs:restriction base="xs:string">
                <xs:enumeration value="True"/>
                <xs:enumeration value="False"/>
            </xs:restriction>
        </xs:simpleType>
    </xs:attribute>
    <xs:attribute name="KeepOnline">
        <xs:simpleType>
            <xs:restriction base="xs:string">
                <xs:enumeration value="True"/>
                <xs:enumeration value="False"/>
            </xs:restriction>
        </xs:simpleType>
    </xs:attribute>
</xs:attributeGroup>

<xs:attributeGroup name="ReorganizeIndexTaskAttributeGroup">
    <xs:attribute name="CompactLargeObjects">
        <xs:simpleType>
            <xs:restriction base="xs:string">
                <xs:enumeration value="True"/>
                <xs:enumeration value="False"/>
            </xs:restriction>
        </xs:simpleType>
    </xs:attribute>
</xs:attributeGroup>

<xs:attributeGroup name="ShrinkDBTaskAttributeGroup">
    <xs:attribute name="DatabaseSizeLimit" type="xs:int"/>

```

```

<xs:attribute name="DatabasePercentLimit" type="xs:int"/>
<xs:attribute name="DatabaseReturnFreeSpace">
  <xs:simpleType>
    <xs:restriction base="xs:string">
      <xs:enumeration value="True"/>
      <xs:enumeration value="False"/>
    </xs:restriction>
  </xs:simpleType>
</xs:attribute>
</xs:attributeGroup>

<xs:attributeGroup name="UpdateStatisticsTaskAttributeGroup">
  <xs:attribute name="UpdateStatisticsType"
    type="SQLTask:SqlTaskUpdateStatisticsTypeEnum"/>
  <xs:attribute name="UpdateScanType"
    type="SQLTask:SqlTaskUpdateScanTypeEnum"/>
  <xs:attribute name="UpdateSampleValue" type="xs:int"/>
</xs:attributeGroup>

<xs:simpleType name="SqlTaskUpdateStatisticsTypeEnum">
  <xs:restriction base="xs:int">
    <xs:minInclusive value="0"/>
    <xs:maxInclusive value="2"/>
  </xs:restriction>
</xs:simpleType>

<xs:simpleType name="SqlTaskUpdateScanTypeEnum">
  <xs:restriction base="xs:int">
    <xs:minInclusive value="2"/>
    <xs:maxInclusive value="3"/>
  </xs:restriction>
</xs:simpleType>

<xs:attributeGroup name="TSQLExecuteTaskAttributeGroup">
</xs:attributeGroup>

<!--The following complex types are not accessed by the formal XSD.
They are used for copy/paste into section 2.6.4.x to document behavior
of specific ExecutableType types-->

<xs:complexType name="SqlTaskDataElementSqlTaskType">
  <xs:sequence/>
  <xs:attributeGroup
    ref="SQLTask:SqlTaskBaseAttributeGroup"/>
</xs:complexType>

<xs:complexType name="SqlTaskDataElementBackupTaskType">
  <xs:sequence>
    <xs:element name="SelectedDatabases"
      type="SQLTask:SelectedDatabasesType"
      minOccurs="0" maxOccurs="unbounded"/>
  </xs:sequence>
  <xs:attributeGroup
    ref="SQLTask:SqlTaskBaseAttributeGroup"/>
  <xs:attributeGroup
    ref="SQLTask:MaintenanceTaskBaseAttributeGroup"/>
  <xs:attributeGroup
    ref="SQLTask:BackupTaskAttributeGroup"/>
  <!--Need to ck elements and other attr for backup task-->

```

```

</xs:complexType>

<xs:complexType name="SqlTaskDataElementCheckIntegrityTaskType">
  <xs:sequence>
    <xs:element name="SelectedDatabases"
      type="SQLTask:SelectedDatabasesType"
      minOccurs="0" maxOccurs="unbounded"/>
    <xs:element name="BackupDestinationList"
      type="SQLTask:BackupDestinationListType"
      minOccurs="0" maxOccurs="unbounded"/>
  </xs:sequence>
  <xs:attributeGroup
    ref="SQLTask:SqlTaskBaseAttributeGroup"/>
  <xs:attributeGroup
    ref="SQLTask:MaintenanceTaskBaseAttributeGroup"/>
  <xs:attributeGroup
    ref="SQLTask:CheckIntegrityTaskAttributeGroup"/>
  <xs:attribute name="DatabaseSelectionType"
    type="SQLTask:SqlTaskDatabaseSelectionTypeEnum"/>
</xs:complexType>

<xs:complexType name="SqlTaskDataElementAgentJobTaskType">
  <xs:sequence/>
  <xs:attributeGroup
    ref="SQLTask:SqlTaskBaseAttributeGroup"/>
  <xs:attributeGroup
    ref="SQLTask:MaintenanceTaskBaseAttributeGroup"/>
  <xs:attributeGroup
    ref="SQLTask:AgentJobTaskAttributeGroup"/>
</xs:complexType>

<xs:complexType name="SqlTaskDataElementHistoryCleanupTaskType">
  <xs:sequence/>
  <xs:attributeGroup
    ref="SQLTask:SqlTaskBaseAttributeGroup"/>
  <xs:attributeGroup
    ref="SQLTask:MaintenanceTaskBaseAttributeGroup"/>
  <xs:attributeGroup
    ref="SQLTask:HistoryCleanupTaskAttributeGroup"/>
  <xs:attribute name="RemoveOlderThan" type="xs:int"/>
  <xs:attribute name="TimeUnitsType"
    type="SQLTask:SqlTaskTimeUnitsTypeEnum"/>
</xs:complexType>

<xs:complexType
  name="SqlTaskDataElementMaintenanceFileCleanupTaskType">
  <xs:sequence/>
  <xs:attributeGroup
    ref="SQLTask:SqlTaskBaseAttributeGroup"/>
  <xs:attributeGroup
    ref="SQLTask:MaintenanceTaskBaseAttributeGroup"/>
  <xs:attributeGroup
    ref="SQLTask:MaintenanceFileCleanupTaskAttributeGroup"/>
  <xs:attribute name="RemoveOlderThan" type="xs:int"/>
  <xs:attribute name="TimeUnitsType"
    type="SQLTask:SqlTaskTimeUnitsTypeEnum"/>
</xs:complexType>

<xs:complexType name="SqlTaskDataElementNotifyOperatorTaskType">

```

```

<xs:sequence>
  <xs:element name="OperatorNotifyList"
    type="SQLTask:OperatorNotifyListType"
    minOccurs="0" maxOccurs="unbounded"/>
</xs:sequence>
<xs:attributeGroup
  ref="SQLTask:SqlTaskBaseAttributeGroup"/>
<xs:attributeGroup
  ref="SQLTask:MaintenanceTaskBaseAttributeGroup"/>
<xs:attributeGroup
  ref="SQLTask:NotifyOperatorTaskAttributeGroup"/>
</xs:complexType>

<xs:complexType name="SqlTaskDataElementRebuildIndexTaskType">
  <xs:sequence>
    <xs:element name="SelectedDatabases"
      type="SQLTask:SelectedDatabasesType"
      minOccurs="0" maxOccurs="unbounded"/>
  </xs:sequence>
  <xs:attributeGroup
    ref="SQLTask:SqlTaskBaseAttributeGroup"/>
  <xs:attributeGroup
    ref="SQLTask:MaintenanceTaskBaseAttributeGroup"/>
  <xs:attributeGroup
    ref="SQLTask:RebuildIndexTaskAttributeGroup"/>
  <xs:attribute name="DatabaseSelectionType"
    type="SQLTask:SqlTaskDatabaseSelectionTypeEnum"/>
</xs:complexType>

<xs:complexType
  name="SqlTaskDataElementReorganizeIndexTaskType">
  <xs:sequence>
    <xs:element name="SelectedDatabases"
      type="SQLTask:SelectedDatabasesType"
      minOccurs="0" maxOccurs="unbounded"/>
  </xs:sequence>
  <xs:attributeGroup
    ref="SQLTask:SqlTaskBaseAttributeGroup"/>
  <xs:attributeGroup
    ref="SQLTask:MaintenanceTaskBaseAttributeGroup"/>
  <xs:attributeGroup
    ref="SQLTask:ReorganizeIndexTaskAttributeGroup"/>
  <xs:attribute name="DatabaseSelectionType"
    type="SQLTask:SqlTaskDatabaseSelectionTypeEnum"/>
</xs:complexType>

<xs:complexType
  name="SqlTaskDataElementShrinkDatabaseTaskType">
  <xs:sequence>
    <xs:element name="SelectedDatabases"
      type="SQLTask:SelectedDatabasesType"
      minOccurs="0" maxOccurs="unbounded"/>
  </xs:sequence>
  <xs:attributeGroup
    ref="SQLTask:SqlTaskBaseAttributeGroup"/>
  <xs:attributeGroup
    ref="SQLTask:MaintenanceTaskBaseAttributeGroup"/>
  <xs:attributeGroup
    ref="SQLTask:ShrinkDBTaskAttributeGroup"/>

```

```

        <xs:attribute name="DatabaseSelectionType"
                    type="SQLTask:SqlTaskDatabaseSelectionTypeEnum"/>
</xs:complexType>

<xs:complexType
  name="SqlTaskDataElementUpdateStatisticsTaskType">
  <xs:sequence>
    <xs:element name="SelectedDatabases"
                type="SQLTask:SelectedDatabasesType"
                minOccurs="0" maxOccurs="unbounded"/>
  </xs:sequence>
  <xs:attributeGroup
    ref="SQLTask:SqlTaskBaseAttributeGroup"/>
  <xs:attributeGroup
    ref="SQLTask:MaintenanceTaskBaseAttributeGroup"/>
  <xs:attributeGroup
    ref="SQLTask:UpdateStatisticsTaskAttributeGroup"/>
  <xs:attribute name="DatabaseSelectionType"
                type="SQLTask:SqlTaskDatabaseSelectionTypeEnum"/>
</xs:complexType>

<xs:complexType name="SqlTaskDataElementTSQLExecuteTaskType">
  <xs:sequence/>
  <xs:attributeGroup
    ref="SQLTask:SqlTaskBaseAttributeGroup"/>
  <xs:attributeGroup
    ref="SQLTask:MaintenanceTaskBaseAttributeGroup"/>
</xs:complexType>
</xs:schema>

```

6 Appendix B: Product Behavior

The information in this specification is applicable to the following Microsoft products or supplemental software. References to product versions include released service packs:

- Microsoft® SQL Server® 2008
- Microsoft® SQL Server® 2008 R2
- Microsoft® SQL Server® 2012

Exceptions, if any, are noted below. If a service pack or Quick Fix Engineering (QFE) number appears with the product version, behavior changed in that service pack or QFE. The new behavior also applies to subsequent service packs of the product unless otherwise specified. If a product edition appears with the product version, behavior is different in that product edition.

Unless otherwise specified, any statement of optional behavior in this specification that is prescribed using the terms SHOULD or SHOULD NOT implies product behavior in accordance with the SHOULD or SHOULD NOT prescription. Unless otherwise specified, the term MAY implies that the product does not follow the prescription.

[<1> Section 2:](#) Integration Services provides user options for encryption. The default is that sensitive properties are not included in the clear text file. Options are provided to include sensitive information in the structure file in encrypted form.

[<2> Section 2.1.2:](#) The Integration Services user interface generates package files, which do not adhere to the sequence that is stated in the XSD.

[<3> Section 2.4:](#) The Integration Services user interface generates a unique value for the **refId** attribute value at the time of object creation.

[<4> Section 2.4.3.2:](#) The **InnerObject** element is always empty.

[<5> Section 2.4.4.1:](#) The Integration Services user interface generates a unique value for the **refId** attribute value at the time of object creation.

[<6> Section 2.4.4.1.2.1.1:](#) If a value for the **LocalID** attribute is not specified, the default value that is set in the Windows operating system is obtained from the system and used.

[<7> Section 2.4.4.1.2.1.1:](#) The value of the **RowDelimiter** attribute is not used by Integration Services.

[<8> Section 2.4.4.1.2.1.1:](#) If a value for the **CodePage** attribute is not specified, the default value that is set in the Windows operating system is obtained from the operating system and used.

[<9> Section 2.4.4.1.2.1.1:](#) The **RetainData** enumeration value is not used by Integration Services.

[<10> Section 2.4.4.1.2.3:](#) The SMO object model is available only on the SQL Server database.

[<11> Section 2.4.6:](#) The value of this property is not processed by Integration Services.

[<12> Section 2.4.6:](#) The value of this property is not processed by Integration Services. By default, the Integration Services UI places the domain-qualified logon name of the package creator in this field.

<13> [Section 2.4.6](#): The value of this property is not processed by Integration Services. By default, the Integration Services UI places the domain name of the computer on which the package was created in this field.

<14> [Section 2.4.6](#): The value of this property is not processed by Integration Services. By default, the Integration Services UI places the date/time value obtained from the operating system in this field.

<15> [Section 2.4.6](#): This field is for documentation and is not processed by Integration Services.

<16> [Section 2.4.6](#): The **VersionBuild** value is incremented every time the package is saved when operating in the Integration Services user interface or through the Integration Services runtime object model.

<17> [Section 2.4.6](#): The **VersionGUID** value changes every time the package is saved.

<18> [Section 2.4.6](#): The Integration Services user interface sets the **LastModifiedProductVersion** attribute to the version of the installed version of SQL Server that is present on the local machine.

<19> [Section 2.5.1](#): This integer value is not currently used by the Integration Services system.

<20> [Section 2.5.1](#): The Integration Services user interface generates a unique value for the **refId** attribute value at the time of object creation.

<21> [Section 2.5.3](#): Integration Services sets the **ExecutionLocation** value to 0.

<22> [Section 2.5.3](#): Integration Services sets the **ExecutionAddress** value to EMPTY.

<23> [Section 2.5.3](#): Integration Services sets **MaxConcurrent** to 1.

<24> [Section 2.5.3](#): The **LockName** property is left blank by Integration Services. If a value is present, it is ignored by Integration Services.

<25> [Section 2.7.1.1.1](#): The default for the **defaultBufferMaxRows** attribute value is 10,000 rows.

<26> [Section 2.7.1.1.1](#): The default value for the **engineThreads** attribute is 5. The data flow engine can, in some circumstances, exceed the **engineThreads** value. If the value is set higher than the data flow engine needs, the data flow engine uses only the number of threads that it needs.

<27> [Section 2.7.1.1.1](#): The default for the **defaultBufferSize** attribute is 10 megabytes.

<28> [Section 2.7.1.1.1](#): The default value that is used for the **BLOBTempStoragePath** attribute value is the folder that the Windows TMP environment variable points to.

<29> [Section 2.7.1.1.1](#): The default value that is used for the **bufferTempStoragePath** attribute value is the folder that the Windows TEMP environment variable points to.

<30> [Section 2.7.1.1.1.1](#): The Integration Services user interface generates a unique value for the **refId** attribute value at the time of object creation.

<31> [Section 2.7.1.1.1.1](#): The **validateExternalMetadata** attribute specifies whether the Visual Studio user interface validates column data against its external data source at design time.

TRUE specifies that the user interface validates column data against external data sources at design time.

FALSE specifies that the user interface does not validate external metadata against its external data source at design time.

<32> [Section 2.7.1.1.1.1.1.1.1](#): Integration Services does not process the contents of the **contactInfo** attribute value.

<33> [Section 2.7.1.1.1.1.1.1.2.11](#): A value of 0 for the **MaxMemoryUsage** property element value indicates that the system dynamically sets the memory usage.

<34> [Section 2.7.1.1.1.1.1.1.2.12](#): A value of 0 for the **MaxMemoryUsage** attribute specifies that the cache size has no limit.

<35> [Section 2.7.1.1.1.1.1.1.2.12](#): This value MUST be a valid SQL Server identifier name.

<36> [Section 2.7.1.1.1.1.1.1.2.12](#): The **ReferenceMetadataXml** attribute value is not used by Integration Services.

<37> [Section 2.7.1.1.1.1.1.1.2.14](#): The **ReferenceMetadataXml** attribute value is not used by Integration Services.

<38> [Section 2.7.1.1.1.1.1.1.2.23](#): The **VSTAProjectName** attribute is the project name of the Visual Studio for Applications project.

<39> [Section 2.7.1.1.1.1.1.1.2.25](#): A value of 0 for the **MaximumThreads** attribute specifies that the maximum number of threads is unlimited.

<40> [Section 2.7.1.1.1.1.1.1.2.30](#): The value of 0 for the **BatchSize** attribute indicates that the batch size is set to the internal buffer size.

<41> [Section 2.7.1.1.1.1.1.1.2.30](#): The value of 0 for the **CommandTimeout** attribute indicates that there is no timeout.

<42> [Section 2.7.1.1.1.1.1.1.2.31](#): The value of 0 for the **CommandTimeout** attribute indicates that there is no timeout.

<43> [Section 2.7.1.1.1.1.1.1.2.31](#): The **FastLoadOptions** property applies to Microsoft products such as SQL Server and Office Excel. It may not be applicable to servers or applications from other vendors.

<44> [Section 2.7.1.1.1.1.1.1.2.33](#): The value of 0 for the **CommandTimeout** attribute indicates that there is no timeout.

<45> [Section 2.7.1.1.1.1.1.1.2.33](#): The **FastLoadOptions** property applies to Microsoft products such as SQL Server and Office Excel. It may not be applicable to servers or applications from other vendors.

<46> [Section 2.7.1.1.1.1.1.1.2.36](#): The contents of the **ObjectRef** string apply only to the Microsoft Object Model, AMO.

<47> [Section 2.7.1.1.1.1.1.1.2.37](#): The contents of the **ObjectRef** string applies only to the Microsoft Object Model, AMO.

<48> [Section 2.7.1.1.1.1.1.1.2.41](#): The value -1 indicates that no value is assigned to the **BulkInsertFirstRow** attribute.

<49> [Section 2.7.1.1.1.1.1.1.2.41](#): If the value of the **LastRow** attribute is -1, the value is not set.

<50> [Section 2.7.1.1.1.1.1.1.2.41](#): The value 0 for the **Timeout** attribute indicates that SQL Server does not time out.

<51> [Section 2.7.1.1.1.1.1.2.41](#): When the **MaxInsertCommitSize** attribute value is set to 0, all rows are inserted in a single batch.

<52> [Section 2.7.1.1.1.1.1.2.42](#): The value of 0 for the **CommandTimeout** attribute indicates that there is no timeout.

<53> [Section 2.7.1.1.1.1.1.2.42](#): For more information about how Integration Services converts external types to strings, see [\[MSDN-ADONETSRC\]](#).

<54> [Section 2.7.1.1.1.1.1.2.43](#): The value of 0 for the **CommandTimeout** attribute indicates that there is no timeout.

<55> [Section 2.7.1.1.1.1.1.2.45](#): The value of 0 for the **CommandTimeout** attribute indicates that there is no timeout.

<56> [Section 2.7.1.1.1.1.2.1](#): The Integration Services user interface generates a unique value for the **refId** attribute value at the time of object creation.

<57> [Section 2.7.1.1.1.3.1.3.1.29](#): A value of -1 for the **DestinationColumn** property indicates that the column is not mapped to an output column.

<58> [Section 2.7.1.1.1.4.1.2.1.20](#): A value of -1 for the **SourceColumn** attribute indicates that the column is not used for pivoting.

<59> [Section 2.7.1.1.1.5](#): For the **PipelineComponentClassIDEnum** value of "{874F7595-FB5F-40FF-96AF-FBFF8250E3EF}", the list of components can be distinguished by the **UserComponentTypeName** attribute value on the component element.

<60> [Section 2.7.1.1.1.6.2](#): The Integration Services user interface generates a unique value for the **refId** attribute value at the time of object creation.

<61> [Section 2.7.1.1.1.6.3](#): The Integration Services user interface generates a unique value for the **refId** attribute value at the time of object creation.

<62> [Section 2.7.1.1.1.6.4](#): This value is assigned by the Integration Services engine when a column is created and is used internally by the Integration Services engine to track the relationships between input columns and output columns that are downstream from this column and that reference this column.

<63> [Section 2.7.1.1.2.1](#): The Integration Services user interface generates a unique value for the **refId** attribute value at the time of object creation.

<64> [Section 2.7.1.5.1.2](#): The value 0 for **BatchSize** indicates default behavior, which is that all rows in the data file are processed as one transaction.

<65> [Section 2.7.1.5.1.2](#): A value of 0 for the **LastRow** attribute indicates default behavior, which is to process to the end of the file.

<66> [Section 2.7.1.5.1.2.1](#): In SQL Server, for the **DTS_BulkInsert_DataFileType_Native** enumeration value, the data file to load is created by bulk copying SQL Server data by using the **bcp utility**. For more information about the bcp utility, see [\[MSDN-BCPU\]](#).

<67> [Section 2.7.1.5.1.2.1](#): In SQL Server, for the **DTS_BulkInsert_DataFileType_NativeWide** enumeration value, the data file to load is created by bulk copying SQL Server data by using the bcp utility.

<68> [Section 2.7.1.5.1.2.2:](#) The Bulk Insert Task works only in conjunction with SQL Server as the server. When the **CodePageType** attribute is set to the value "ACP", the code page is converted from the ANSI code page to the SQL Server code page.

<69> [Section 2.7.1.5.1.2.2:](#) The Bulk Insert Task works only in conjunction with SQL Server as the server. When the **CodePageType** attribute is set to the value "OEM", the code page is converted to the SQL Server code page.

<70> [Section 2.7.1.6:](#) This string is in the Data Mining Extensions (DMX) [\[MSDN-DMXR\]](#) language.

<71> [Section 2.7.1.7.1.1.1:](#) The contents of the **DataSourcesType** type are dynamically generated by Integration Services and contain a reference to each ConnectionManager in the Integration Services package file. If any contents are present in this element in the package file, the content is ignored and dynamically regenerated as just stated.

<72> [Section 2.7.1.7.1.1.2:](#) For Integration Services, the **ProfileMode** element MUST be set to the value "Exact". Fast mode is not supported.

<73> [Section 2.7.1.7.1.1.2.1.4.1:](#) By default, if the **FrequentValueThreshold** value is not specified, Integration Services sets the value to 0.001.

<74> [Section 2.7.1.7.1.1.2.2.1.6.1:](#) By default, if the **KeyStrengthThreshold** element value is not specified, the value of 0.95 is used.

<75> [Section 2.7.1.7.1.1.2.2.1.6.1:](#) Integration Services supports the value FALSE only for the **VerifyOutputInFastMode** element.

<76> [Section 2.7.1.7.1.1.2.2.1.6.1:](#) The default value for the **MaxNumberOfViolations** element is 100.

<77> [Section 2.7.1.7.1.1.2.2.1.7.1:](#) The default value of 0.95 is used for the value of the **FDStrengthThreshold** element if the value of the **FDStrengthThreshold** element is not specified.

<78> [Section 2.7.1.7.1.1.2.2.1.7.1:](#) Integration Services supports the value FALSE only for the **VerifyOutputInFastMode** element.

<79> [Section 2.7.1.7.1.1.2.2.1.7.1:](#) The default value for the **MaxNumberOfViolations** element is 100.

<80> [Section 2.7.1.7.1.1.2.2.1.8.1:](#) The **SupersetDataSourceID** attribute MUST be equal to the **SubsetDataSourceID** attribute.

<81> [Section 2.7.1.7.1.1.2.2.1.8.1:](#) By default, if the value of the **InclusionStrengthThreshold** element is not specified, the value 0.95 is used.

<82> [Section 2.7.1.7.1.1.2.2.1.8.1:](#) By default, if the value of the **SupersetColumnsKeyThreshold** element is not specified, the value 0.95 is used.

<83> [Section 2.7.1.7.1.1.2.2.1.8.1:](#) Integration Services supports the value FALSE only for the **VerifyOutputInFastMode** element.

<84> [Section 2.7.1.7.1.1.2.2.1.8.1:](#) The default value for the **MaxNumberOfViolations** element is 100.

<85> [Section 2.7.1.7.1.1.2.2.1.9.1:](#) If the **MaxNumberOfPatterns** element is not specified, the default value is 10.

<86> [Section 2.7.1.7.1.1.2.2.1.9.1](#): If the **PercentageDataCoverageDesired** element is not specified, the default value is 95.

<87> [Section 2.7.1.7.1.1.2.2.1.9.1](#): If the **CaseSensitive** element is not specified, the default value is FALSE.

<88> [Section 2.7.1.7.1.1.2.2.1.9.1](#): By default, the list of **Delimiter** elements contains the following characters:

- Space
- Horizontal tab (\t)
- New line (\n)
- Carriage return (\r)

Additional **Delimiter** elements can be specified, but the default delimiters cannot be removed.

<89> [Section 2.7.1.7.1.1.2.2.1.9.1](#): By default, the list of symbols contains the following characters:

,
.
;
:
-
"
'
,
~
=
&
/
\
@
!
?
(
)
<

>
[
]
{
}
|

*
^
%

<90> [Section 2.7.1.7.1.1.3](#): The contents of the **DataProfileOutputType** complex type are not used in the package file. If the **DataProfileOutputType** complex type is present, any content is ignored.

<91> [Section 2.7.1.7.1.1.3](#): The **Profiles** element is enforced to be empty. Any content that is present is ignored during package file processing.

<92> [Section 2.7.1.8.1.1.1](#): In the Microsoft implementation, every time the package is saved, a new GUID value is generated for the **PackageVersionGUID** attribute.

<93> [Section 2.7.1.8.1.1.1](#): In the Microsoft implementation, the **SQLServer** attribute value is the name of an instance of SQL Server.

<94> [Section 2.7.1.8.1.1.1](#): In the Microsoft implementation, the database username is a specific SQL Server username. The **SQLUsername** attribute value is used only if the **WindowsAuthentication** attribute has a value of "False".

<95> [Section 2.7.1.8.1.1.1.1](#): In the Microsoft implementation, the "SQLServer" enumeration value specifies that the DTS2000 Package file is stored on a SQL Server Database server.

<96> [Section 2.7.1.11.1.1.1.8](#): If a value for the **CodePage** attribute is not specified, the default value that is set in the Windows operating system is obtained from the operating system and used.

<97> [Section 2.7.1.14.1.1.1](#): The **DTSMessageLineageID** attribute value is not used by the Integration Services system. Any value given for this attribute is ignored by Integration Services.

<98> [Section 2.7.1.14.1.1.1](#): The **Use2000Format** attribute specifies whether the message is formatted with the SQL Server 2000 format.

"True" specifies that the message is formatted with the SQL Server 2000 format.

"False" specifies that the message is not formatted with the SQL Server 2000 format.

<99> [Section 2.7.1.15](#): The **VSTAMajorVersion** integer value specifies the Visual Studio Tools for Applications (VSTA) major version number.

<100> [Section 2.7.1.15](#): The **VSTAMinorVersion** integer value specifies the VSTA minor version number.

[<101> Section 2.7.1.15.3:](#) This string value is used by Visual Studio for supporting the debugging environment and is not set or interpreted by Integration Services.

[<102> Section 2.7.1.22:](#) Database logins are the logins authorized to the SQL Server instance.

[<103> Section 2.8.5.1:](#) The Integration Services user interface generates a unique value for the **refId** attribute value at the time of object creation.

[<104> Section 2.8.5.1.1:](#) The content of the **EventID** attribute value is ignored by the Integration Services system.

[<105> Section 2.8.6.1:](#) The Integration Services user interface generates a unique value for the **refId** attribute value at the time of object creation.

[<106> Section 2.9.1:](#) The content of the **Description** string is not processed by the Integration Services system.

[<107> Section 2.9.1:](#) The Integration Services user interface generates a random unique value for the **DTSID** attribute value.

[<108> Section 2.9.1:](#) The Integration Services user interface generates a value for the **CreationName** attribute value at the time of object creation.

[<109> Section 2.9.1:](#) The Integration Services user interface generates a value for the **ObjectName** attribute value at the time of object creation.

[<110> Section 2.9.2:](#) If a value for the LCID attribute is not specified, the default value that is set in the Windows operating system is obtained from the system and used.

[<111> Section 2.9.10:](#) The **InnerObjectObjectType** type is empty for all standard components that ship with the Integration Services product.

7 Change Tracking

No table of changes is available. The document is either new or has had no changes since its last release.

8 Index

[<xs:sequence> usage](#) 29

A

ActiveX Script Task
 [ExecutableType instance for](#) 114
[ActiveXScriptTaskData element](#) 271
[AllExecutableAttributeGroup attribute group](#) 407
[AnyNonPackageExecutableAttributeGroup attribute group](#) 108
[AnyNonPackageExecutableType complex type](#) 84
[AnyNonPackageExecutableTypeExecutableTypeEnum type](#) 88
AS Execute DDL Task
 [ExecutableType instance for](#) 116
AS Processing Task
 [ExecutableType instance for](#) 117
[ASDdlDataObjectDataType complex type](#) 272
[ASProcessingDataObjectDataType complex type](#) 273

B

Backup Task
 [ExecutableType instance for](#) 154
[BaseExecutablePropertyAttributeGroup attribute group](#) 404
[BasePropertyAttributeGroup attribute group](#) 403
[BooleanStringCap type](#) 407
Bulk Insert Task
 [ExecutableType instance for](#) 119
[BulkInsertTaskData element](#) 273

C

[Change tracking](#) 593
Check Integrity Task
 [ExecutableType instance for](#) 156
[CheckpointUsageEnum type](#) 80
[ConfigurationsType complex type](#) 36
[ConfigurationType complex type](#) 36
[ConnectionManagersType complex type](#) 41
[ConnectionManagerType complex type](#) 41
[Constraints beyond XSD definitions](#) 29
[Custom component](#) 429
[Custom component example](#) 476
[Custom ConnectionManager](#) 427
[Custom executable](#) 426
[Custom executable example](#) 474
[Custom ForEachEnumerator](#) 428
[Custom log provider](#) 428
[Custom packages](#) 426

D

Data Mining Query Task
 [ExecutableType instance for](#) 121
Data Profiling Task
 [ExecutableType instance for](#) 122

[DataProfilingTaskDataObjectDataType complex type](#) 282
[DesignTimeProperties element](#) 411
[DestinationTypeEnum type](#) 409
[DMQueryTaskDataObjectDataType complex type](#) 279

E

Encryption
 [password](#) 498
 [user key](#) 498
[Encryption implementation](#) 498
[EventHandlersType complex type](#) 396
[Exec80PackageTaskData element](#) 302
[Executable container types](#) 111
[Executable element](#) 30
[Executable maintenance tasks](#) 153
[Executable task types](#) 114
[ExecutableObjectDataType type](#) 176
[ExecutablesType complex type](#) 84
[ExecutableType attribute values](#) 109
ExecutableType instance
 [ActiveX Script Task](#) 114
 [AS Execute DDL Task](#) 116
 [AS Processing Task](#) 117
 [Backup Task](#) 154
 [Bulk Insert Task](#) 119
 [Check Integrity Task](#) 156
 [Data Mining Query Task](#) 121
 [Data Profiling Task](#) 122
 [Execute DTS 2000 Package Task](#) 124
 [Execute Package Task](#) 125
 [Execute Process Task](#) 127
 [Execute SQL Agent Job Task](#) 158
 [Execute SQL Task](#) 128
 [Execute TSQL Task](#) 174
 [File System Task](#) 130
 [FTP Task](#) 132
 [History Cleanup Task](#) 160
 [Maintenance File Cleanup Task](#) 162
 [Message Queue Task](#) 133
 [Rebuild Index Task](#) 166
 [Reorganize Index Task](#) 168
 [Script Task](#) 135
 [Send Mail Task](#) 136
 [Shrink Database Task](#) 170
 [Transfer Database Task](#) 138
 [Transfer Error Messages Task](#) 139
 [Transfer Jobs Task](#) 141
 [Transfer Logins Task](#) 142
 [Transfer SQL Server Objects Task](#) 146
 [Transfer Stored Procedures Task](#) 144
 [Update Statistics Task](#) 172
 [Web Service Task](#) 147
 [WMI Data Reader Task](#) 149
 [WMI Event Watcher Task](#) 150
 [XML Task](#) 152
[ExecutableType instance for ForEachLoop](#) 112

[ExecutableType instance for ForLoop](#) 113
[ExecutableType instance for Pipeline](#) 109
[ExecutableType instance for Sequence](#) 111
[ExecutableTypePackage complex type](#) 30
[ExecutableTypePackageAttributeGroup attribute group](#) 76
[ExecutableTypePackagePropertyNameEnum type](#) 76
Execute DTS 2000 Package Task
[ExecutableType instance for](#) 124
Execute Package Task
[ExecutableType instance for](#) 125
Execute Process Task
[ExecutableType instance for](#) 127
Execute SQL Agent Job Task
[ExecutableType instance for](#) 158
Execute SQL Task
[ExecutableType instance for](#) 128
Execute TSQL Task
[ExecutableType instance for](#) 174
[ExecutePackageTaskObjectDataType complex type](#) 305
[ExecuteProcessDataObjectDataType complex type](#) 306

F

File System Task
[ExecutableType instance for](#) 130
[FileSytemDataObjectDataType complex type](#) 334
ForEachLoop
[ExecutableType instance for](#) 112
[ForEachVariableMappingsType complex type](#) 106
[ForEachVariableMappingType complex type](#) 106
ForLoop
[ExecutableType instance for](#) 113
FTP Task
[ExecutableType instance for](#) 132
[FtpDataObjectDataType complex type](#) 337
[Fuzzy Lookup Component example](#) 432

H

History Cleanup Task
[ExecutableType instance for](#) 160

I

[IfObjectExistsEnum type](#) 410
[InnerObjectObjectDataType complex type](#) 410

L

[LoggingOptionsType complex type](#) 386
[LogProviderAttributeGroup attribute group](#) 40
[LogProviderObjectDataType complex type](#) 40
[LogProviderType complex type](#) 39
[Lookup Component example](#) 432

M

Maintenance File Cleanup Task
[ExecutableType instance for](#) 162

Message Queue Task
[ExecutableType instance for](#) 133
[MessageQueueTaskData element](#) 340

N

[Namespaces](#) 29

P

[PackageParametersType complex type](#) 81
[PackagePriorityClassEnum type](#) 80
[PackageTypeEnum type](#) 79
[PackageVariablesType complex type](#) 33
[PackageVariableType complex type](#) 34
[Password encryption](#) 498
[PassworkElementype complex type](#) 408
[pipelineObjectDataType complex type](#) 177
[PrecedenceConstraintsType complex type](#) 399
[PropertyElementBaseType complex type](#) 383
[PropertyExpressionElementype complex type](#) 386
ProtectionLevel property
[encryption implementation for](#) 498
[ProtectionLevelEnum type](#) 79

R

Rebuild Index Task
[ExecutableType instance for](#) 166
Reorganize Index Task
[ExecutableType instance for](#) 168

S

Script Task
[ExecutableType instance for](#) 135
[Script Task example](#) 456
[ScriptProjectObjectDataType complex type](#) 346
[Security considerations](#) 498
[Security fields](#) 498
Send Mail Task
[ExecutableType instance for](#) 136
[SendMailTaskData element](#) 351
Sequence
[ExecutableType instance for](#) 111
Shrink Database Task
[ExecutableType instance for](#) 170
[SourceTypeEnum type](#) 409
[SqlTaskData element](#) 309

T

[Tracking changes](#) 593
Transfer Database Task
[ExecutableType instance for](#) 138
Transfer Error Messages Task
[ExecutableType instance for](#) 139
Transfer Jobs Task
[ExecutableType instance for](#) 141
Transfer Logins Task
[ExecutableType instance for](#) 142
Transfer SQL Server Objects Task

[ExecutableType instance for](#) 146
Transfer Stored Procedures Task
[ExecutableType instance for](#) 144
[TransferDatabaseTaskDataObjectDataType complex type](#) 354
[TransferErrorMessageTaskDataObjectDataType complex type](#) 356
[TransferJobsTaskDataObjectDataType complex type](#) 357
[TransferLoginsTaskDataObjectDataType complex type](#) 358
[TransferSqlServerObjectsTaskDataObjectDataType complex type](#) 361
[TransferStoredProceduresTaskDataObjectDataType complex type](#) 360

U

Update Statistics Task
[ExecutableType instance for](#) 172
[User key encryption](#) 498
[UUID type](#) 408

W

Web Service Task
[ExecutableType instance for](#) 147
[Web Service Task example](#) 456
[WebServiceTaskData element](#) 368
WMI Data Reader Task
[ExecutableType instance for](#) 149
WMI Event Watcher Task
[ExecutableType instance for](#) 150
[WMIDRTaskDataObjectDataType complex type](#) 372
[WMIEWTaskDataObjectDataType complex type](#) 374

X

XML Task
[ExecutableType instance for](#) 152
[XMLTaskDataObjectDataType complex type](#) 377