

[MS-DTSX]:

Data Transformation Services Package XML File Format

Intellectual Property Rights Notice for Open Specifications Documentation

- **Technical Documentation.** Microsoft publishes Open Specifications documentation (“this documentation”) for protocols, file formats, data portability, computer languages, and standards support. Additionally, overview documents cover inter-protocol relationships and interactions.
- **Copyrights.** This documentation is covered by Microsoft copyrights. Regardless of any other terms that are contained in the terms of use for the Microsoft website that hosts this documentation, you can make copies of it in order to develop implementations of the technologies that are described in this documentation and can distribute portions of it in your implementations that use these technologies or in your documentation as necessary to properly document the implementation. You can also distribute in your implementation, with or without modification, any schemas, IDLs, or code samples that are included in the documentation. This permission also applies to any documents that are referenced in the Open Specifications documentation.
- **No Trade Secrets.** Microsoft does not claim any trade secret rights in this documentation.
- **Patents.** Microsoft has patents that might cover your implementations of the technologies described in the Open Specifications documentation. Neither this notice nor Microsoft's delivery of this documentation grants any licenses under those patents or any other Microsoft patents. However, a given Open Specifications document might be covered by the Microsoft [Open Specifications Promise](#) or the [Microsoft Community Promise](#). If you would prefer a written license, or if the technologies described in this documentation are not covered by the Open Specifications Promise or Community Promise, as applicable, patent licenses are available by contacting iplg@microsoft.com.
- **License Programs.** To see all of the protocols in scope under a specific license program and the associated patents, visit the [Patent Map](#).
- **Trademarks.** The names of companies and products contained in this documentation might be covered by trademarks or similar intellectual property rights. This notice does not grant any licenses under those rights. For a list of Microsoft trademarks, visit www.microsoft.com/trademarks.
- **Fictitious Names.** The example companies, organizations, products, domain names, email addresses, logos, people, places, and events that are depicted in this documentation are fictitious. No association with any real company, organization, product, domain name, email address, logo, person, place, or event is intended or should be inferred.

Reservation of Rights. All other rights are reserved, and this notice does not grant any rights other than as specifically described above, whether by implication, estoppel, or otherwise.

Tools. The Open Specifications documentation does not require the use of Microsoft programming tools or programming environments in order for you to develop an implementation. If you have access to Microsoft programming tools and environments, you are free to take advantage of them. Certain Open Specifications documents are intended for use in conjunction with publicly available standards specifications and network programming art and, as such, assume that the reader either is familiar with the aforementioned material or has immediate access to it.

Support. For questions and support, please contact dochelp@microsoft.com.

Revision Summary

| Date | Revision History | Revision Class | Comments |
|------------|------------------|----------------|--|
| 2/9/2011 | 0.1 | New | Released new document. |
| 7/7/2011 | 0.1 | None | No changes to the meaning, language, or formatting of the technical content. |
| 11/3/2011 | 0.1 | None | No changes to the meaning, language, or formatting of the technical content. |
| 1/19/2012 | 0.1 | None | No changes to the meaning, language, or formatting of the technical content. |
| 2/23/2012 | 0.1 | None | No changes to the meaning, language, or formatting of the technical content. |
| 3/27/2012 | 0.1 | None | No changes to the meaning, language, or formatting of the technical content. |
| 5/24/2012 | 0.1 | None | No changes to the meaning, language, or formatting of the technical content. |
| 6/29/2012 | 0.1 | None | No changes to the meaning, language, or formatting of the technical content. |
| 7/16/2012 | 0.1 | None | No changes to the meaning, language, or formatting of the technical content. |
| 10/8/2012 | 0.1 | None | No changes to the meaning, language, or formatting of the technical content. |
| 10/23/2012 | 0.1 | None | No changes to the meaning, language, or formatting of the technical content. |
| 3/26/2013 | 0.1 | None | No changes to the meaning, language, or formatting of the technical content. |
| 6/11/2013 | 0.1 | None | No changes to the meaning, language, or formatting of the technical content. |
| 8/8/2013 | 0.1 | None | No changes to the meaning, language, or formatting of the technical content. |
| 12/5/2013 | 0.1 | None | No changes to the meaning, language, or formatting of the technical content. |
| 2/11/2014 | 1.0 | Major | Significantly changed the technical content. |
| 5/20/2014 | 1.0 | None | No changes to the meaning, language, or formatting of the technical content. |
| 5/10/2016 | 2.0 | Major | Significantly changed the technical content. |
| 8/16/2017 | 3.0 | Major | Significantly changed the technical content. |
| 5/24/2018 | 4.0 | Major | Significantly changed the technical content. |
| 9/12/2018 | 5.0 | Major | Significantly changed the technical content. |
| 10/16/2019 | 6.0 | Major | Significantly changed the technical content. |

| Date | Revision History | Revision Class | Comments |
|-------------|-------------------------|-----------------------|--|
| 6/22/2020 | 7.0 | Major | Significantly changed the technical content. |

Table of Contents

| | | |
|-----------------|---|-----------|
| 1 | Introduction | 12 |
| 1.1 | Glossary | 12 |
| 1.2 | References | 14 |
| 1.2.1 | Normative References | 14 |
| 1.2.2 | Informative References | 15 |
| 1.3 | Overview | 15 |
| 1.4 | Relationship to Protocols and Other Structures | 18 |
| 1.5 | Applicability Statement | 18 |
| 1.6 | Versioning and Localization | 18 |
| 1.7 | Vendor-Extensible Fields | 18 |
| 2 | Structures | 19 |
| 2.1 | Additional Normative Requirements Concerning the XSD Fragments Provided | 19 |
| 2.1.1 | Constraints beyond the XSD Definitions for Complex Types..... | 19 |
| 2.1.2 | <xs:sequence> Usage Expressed in the XSD is Optional..... | 19 |
| 2.2 | Namespaces..... | 19 |
| 2.3 | Executable Element..... | 19 |
| 2.4 | ExecutableTypePackage | 20 |
| 2.4.1 | PackageVariableType | 22 |
| 2.4.1.1 | PackageVariablePropertyNameEnum..... | 24 |
| 2.4.2 | ConfigurationType | 24 |
| 2.4.2.1 | ConfigurationPropertyNameEnum..... | 26 |
| 2.4.2.1.1 | Property Name=ConfigurationType | 26 |
| 2.4.3 | LogProviderType..... | 27 |
| 2.4.3.1 | LogProviderPropertyNameEnum | 28 |
| 2.4.3.1.1 | Property Name=DelayValidation | 29 |
| 2.4.3.2 | LogProviderObjectDataType | 29 |
| 2.4.4 | ConnectionManagerType..... | 30 |
| 2.4.4.1 | ConnectionManagerPropertyNameEnum | 31 |
| 2.4.4.1.1 | Property Name=DelayValidation | 32 |
| 2.4.4.2 | ConnectionManagerObjectDataType | 32 |
| 2.4.4.2.1 | ConnectionManagerObjectDataConnectionManagerType | 33 |
| 2.4.4.2.1.1 | ConnectionManagerObjectDataPropertyNameEnum | 35 |
| 2.4.4.2.1.1.1 | Property Name=Retain..... | 37 |
| 2.4.4.2.1.1.2 | Property Name=Format..... | 37 |
| 2.4.4.2.1.1.3 | Property Name=Unicode | 38 |
| 2.4.4.2.1.1.4 | Property Name=ColumnNamesInFirstDataRow | 38 |
| 2.4.4.2.1.1.5 | Property Name=UseFile..... | 38 |
| 2.4.4.2.1.1.6 | Property Name=UseEncryption..... | 38 |
| 2.4.4.2.1.1.7 | Property Name=RetainData | 39 |
| 2.4.4.2.1.1.8 | Property Name=FileUsageType | 39 |
| 2.4.4.2.1.2 | FlatFileColumnType | 39 |
| 2.4.4.2.1.2.1 | FlatFileColumnPropertyNameEnum | 40 |
| 2.4.4.2.1.2.1.1 | Property Name=ColumnType..... | 41 |
| 2.4.4.2.1.2.1.2 | Property Name=DataType..... | 41 |
| 2.4.4.2.1.2.1.3 | Property Name=TextQualified | 41 |
| 2.4.4.2.1.3 | CacheColumnType Complex Type..... | 42 |
| 2.4.4.2.1.3.1 | CacheColumnPropertyNameEnum..... | 43 |
| 2.4.4.2.1.4 | FtpConnectionType Complex Type..... | 43 |
| 2.4.4.2.1.4.1 | FtpConnectionPropertyNameEnum | 45 |
| 2.4.4.2.1.4.1.1 | Property Name=UsePassiveMode | 46 |
| 2.4.4.2.1.5 | HttpConnectionType Complex Type | 46 |
| 2.4.4.2.1.5.1 | HttpConnectionPropertyNameEnum | 47 |
| 2.4.4.2.1.5.1.1 | Property Name=UseServerCredentials..... | 48 |
| 2.4.4.2.1.5.1.2 | Property Name=UseSecureConnection..... | 49 |

| | | |
|-----------------|--|----|
| 2.4.4.2.1.5.1.3 | Property Name=UseProxy | 49 |
| 2.4.4.2.1.5.1.4 | Property Name=ByPassProxyOnLocal | 49 |
| 2.4.4.2.1.5.1.5 | Property Name=UseProxyCredentials | 49 |
| 2.4.4.2.2 | ConnectionManagerObjectDataMsmqConnectionManagerType | 50 |
| 2.4.4.2.3 | ConnectionManagerObjectDataSMOServerConnectionManagerType | 50 |
| 2.4.4.2.4 | ConnectionManagerObjectDataSmtpConnectionManagerType | 51 |
| 2.4.4.2.5 | ConnectionManagerObjectDataWmiConnectionManagerType | 51 |
| 2.4.4.3 | ConnectionManagerObjectDataType Information for Data Sources | 52 |
| 2.4.4.3.1 | OLE DB Data Source | 52 |
| 2.4.4.3.2 | Flat File Data Source | 53 |
| 2.4.4.3.3 | ADO.NET Data Source | 54 |
| 2.4.4.3.4 | Analysis Services Data Source | 55 |
| 2.4.4.3.5 | File Data Source | 56 |
| 2.4.4.3.6 | Cache Data Source | 57 |
| 2.4.4.3.7 | Excel Data Source | 58 |
| 2.4.4.3.8 | FTP Data Source | 59 |
| 2.4.4.3.9 | HTTP Data Source | 60 |
| 2.4.4.3.10 | MSMQ Data Source | 61 |
| 2.4.4.3.11 | MULTIFILE Data Source | 62 |
| 2.4.4.3.12 | MULTIFLATFILE Data Source | 62 |
| 2.4.4.3.13 | ODBC Data Source | 64 |
| 2.4.4.3.14 | SMOServer Data Source | 65 |
| 2.4.4.3.15 | SMTP Data Source | 65 |
| 2.4.4.3.16 | SQLMOBILE Data Source | 66 |
| 2.4.4.3.17 | WMI Data Source | 67 |
| 2.4.5 | ExecutableTypePackageNameEnum | 67 |
| 2.4.5.1 | Property Name=PackageType | 69 |
| 2.4.5.2 | Property Name=ProtectionLevel | 69 |
| 2.4.5.3 | Property Name=PackagePriorityClass | 70 |
| 2.4.5.4 | Property Name=SaveCheckpoints | 70 |
| 2.4.5.5 | Property Name=CheckpointUsage | 70 |
| 2.4.5.6 | Property Name=EnableConfig | 71 |
| 2.4.5.7 | Property Name=SuppressConfigurationWarnings | 71 |
| 2.5 | AnyNonPackageExecutableType | 71 |
| 2.5.1 | ForEachEnumeratorType | 74 |
| 2.5.1.1 | ForEachEnumeratorObjectDataType | 75 |
| 2.5.1.1.1 | FEIItemsType | 77 |
| 2.5.1.1.1.1 | FEIItemType | 77 |
| 2.5.1.1.1.1.1 | FEIItemValue Type | 77 |
| 2.5.1.1.2 | ForEachFileEnumeratorPropertiesType | 78 |
| 2.5.1.1.3 | FEEADOType | 79 |
| 2.5.1.1.3.1 | FEEADOEnumType | 79 |
| 2.5.1.1.4 | FEESchemaRowsetType | 80 |
| 2.5.1.1.4.1 | RestrictionElementType | 80 |
| 2.5.1.1.5 | FEFVEType | 81 |
| 2.5.1.1.6 | FEENODELISTType | 81 |
| 2.5.1.1.6.1 | NodelistEnumerationTypeEnum | 82 |
| 2.5.1.1.6.2 | NodelistInnerElementEnumerationTypeEnum | 83 |
| 2.5.1.1.7 | FEESMOType | 83 |
| 2.5.2 | ForEachVariableMappingType | 84 |
| 2.5.2.1 | ForEachVariableMappingPropertyNameEnum | 85 |
| 2.5.3 | AnyNonPackageExecutableTypePropertyNameEnum | 86 |
| 2.6 | ExecutableType Attribute Values for Different Executable Types | 87 |
| 2.6.1 | ExecutableType Instance for Pipeline Task | 87 |
| 2.6.2 | Executable Container Types | 89 |
| 2.6.2.1 | ExecutableType Instance for Sequence | 89 |
| 2.6.2.2 | ExecutableType Instance for ForEachLoop | 90 |
| 2.6.2.3 | ExecutableType Instance for ForLoop | 91 |

| | | |
|-------------------|--|-----|
| 2.6.3 | Executable Task Types | 93 |
| 2.6.3.1 | ExecutableType Instance for ActiveX Script Task..... | 93 |
| 2.6.3.1.1 | TaskExePropertyNameEnum Type..... | 94 |
| 2.6.3.2 | ExecutableType Instance for AS Execute DDL Task..... | 95 |
| 2.6.3.3 | ExecutableType Instance for AS Processing Task..... | 97 |
| 2.6.3.4 | ExecutableType Instance for Bulk Insert Task..... | 98 |
| 2.6.3.5 | ExecutableType Instance for Data Mining Query Task | 100 |
| 2.6.3.6 | ExecutableType Instance for Data Profiling Task | 101 |
| 2.6.3.7 | ExecutableType Instance for Execute DTS 2000 Package Task | 103 |
| 2.6.3.8 | ExecutableType Instance for Execute Package Task..... | 105 |
| 2.6.3.9 | ExecutableType Instance for Execute Process Task..... | 106 |
| 2.6.3.10 | ExecutableType Instance for Execute SQL Task..... | 108 |
| 2.6.3.11 | ExecutableType Instance for File System Task | 110 |
| 2.6.3.12 | ExecutableType Instance for FTP Task | 111 |
| 2.6.3.13 | ExecutableType Instance for Message Queue Task | 113 |
| 2.6.3.14 | ExecutableType Instance for Script Task | 114 |
| 2.6.3.15 | ExecutableType Instance for Send Mail Task..... | 116 |
| 2.6.3.16 | ExecutableType Instance for Transfer Database Task..... | 117 |
| 2.6.3.17 | ExecutableType Instance for Transfer Error Messages Task | 119 |
| 2.6.3.18 | ExecutableType Instance for Transfer Jobs Task | 121 |
| 2.6.3.19 | ExecutableType Instance for Transfer Logins Task..... | 122 |
| 2.6.3.20 | ExecutableType Instance for Transfer Stored Procedures Task | 124 |
| 2.6.3.21 | ExecutableType Instance for Transfer SQL Server Objects Task | 126 |
| 2.6.3.22 | ExecutableType Instance for Web Service Task..... | 127 |
| 2.6.3.23 | ExecutableType Instance for WMI Data Reader Task..... | 129 |
| 2.6.3.24 | ExecutableType Instance for WMI Event Watcher Task | 131 |
| 2.6.3.25 | ExecutableType Instance for XML Task | 132 |
| 2.6.4 | Executable Maintenance Tasks | 134 |
| 2.6.4.1 | ExecutableType Instance for Backup Task | 134 |
| 2.6.4.2 | ExecutableType Instance for Check Integrity Task..... | 136 |
| 2.6.4.3 | ExecutableType Instance for Execute SQL Agent Job Task..... | 138 |
| 2.6.4.4 | ExecutableType Instance for History Cleanup Task | 140 |
| 2.6.4.5 | ExecutableType Instance for Maintenance File Cleanup Task..... | 142 |
| 2.6.4.6 | ExecutableType Instance for Notify Operator Task..... | 144 |
| 2.6.4.7 | ExecutableType Instance for Rebuild Index Task..... | 146 |
| 2.6.4.8 | ExecutableType Instance for Reorganize Index Task..... | 148 |
| 2.6.4.9 | ExecutableType Instance for Shrink Database Task | 150 |
| 2.6.4.10 | ExecutableType Instance for Update Statistics Task..... | 152 |
| 2.6.4.11 | ExecutableType Instance for Execute TSQL Task..... | 154 |
| 2.7 | Executable ObjectData Types | 156 |
| 2.7.1 | ExecutableObjectDataType | 156 |
| 2.7.1.1 | pipelineObjectDataType | 157 |
| 2.7.1.1.1 | PipelineComponentsType..... | 158 |
| 2.7.1.1.1.1 | PipelineComponentType..... | 158 |
| 2.7.1.1.1.1.1 | PipelineComponentPropertiesType | 160 |
| 2.7.1.1.1.1.1.1 | PipelineComponentPropertyType..... | 160 |
| 2.7.1.1.1.1.1.1.1 | PipelineComponentArrayElementsType..... | 161 |
| 2.7.1.1.1.1.1.1.2 | PipelineComponentPropertyNameEnum | 162 |
| 2.7.1.1.1.1.1.1.3 | PipelineComponentDataTypeEnum | 187 |
| 2.7.1.1.1.1.1.1.4 | PipelineComponentStateEnum | 188 |
| 2.7.1.1.1.1.1.1.5 | PipelineComponentExpressionTypeEnum | 188 |
| 2.7.1.1.1.1.2 | PipelineComponentConnectionsType | 189 |
| 2.7.1.1.1.1.2.1 | PipelineComponentConnectionType | 189 |
| 2.7.1.1.1.1.3 | PipelineComponentInputsType | 190 |
| 2.7.1.1.1.1.3.1 | PipelineComponentInputType | 190 |
| 2.7.1.1.1.1.3.1.1 | PipelineComponentInputColumnsType | 191 |
| 2.7.1.1.1.1.3.1.2 | PipelineComponentInputColumnType | 191 |
| 2.7.1.1.1.1.3.1.3 | PipelineComponentInputColumnPropertiesType..... | 192 |

| | | |
|-------------------|--|-----|
| 2.7.1.1.1.1.3.1.4 | PipelineComponentInputPropertiesType | 202 |
| 2.7.1.1.1.1.3.1.5 | PipelineComponentInputPropertyType | 203 |
| 2.7.1.1.1.1.3.1.6 | PipelineComponentInputPropertyNameEnum | 204 |
| 2.7.1.1.1.4 | PipelineComponentOutputsType | 204 |
| 2.7.1.1.1.4.1 | PipelineComponentOutputType | 204 |
| 2.7.1.1.1.4.1.1 | PipelineComponentOutputColumnsType | 206 |
| 2.7.1.1.1.4.1.2 | PipelineComponentOutputPropertiesType | 217 |
| 2.7.1.1.1.4.1.3 | PipelineComponentOutputPropertyNameEnum | 218 |
| 2.7.1.1.1.5 | PipelineComponentComponentClassIDEnum | 222 |
| 2.7.1.1.1.6 | Attribute Groups and Common Types Used by Components | 225 |
| 2.7.1.1.1.6.1 | PipelineComponentMetadataColumnsType | 225 |
| 2.7.1.1.1.6.1.1 | PipelineComponentMetadataColumnType | 226 |
| 2.7.1.1.1.6.2 | PipelineComponentRowDispositionEnum | 229 |
| 2.7.1.1.1.6.3 | PipelineComponentInputOutputElementAttributeGroup | 230 |
| 2.7.1.1.1.6.4 | PipelineComponentAllColumnBaseAttributeGroup | 231 |
| 2.7.1.1.1.6.5 | PipelineComponentIOColumnBaseAttributeGroup | 231 |
| 2.7.1.1.1.6.6 | PipelineComponentColumnExtendedAttributeGroup | 232 |
| 2.7.1.1.1.6.6.1 | PipelineComponentColumnDataTypeEnum | 233 |
| 2.7.1.1.1.6.7 | PipelineComponentPropertyAttributeGroup | 235 |
| 2.7.1.1.2 | PipelinePathsType | 236 |
| 2.7.1.1.2.1 | PipelinePathType | 236 |
| 2.7.1.2 | ActiveXScriptTaskData Element | 237 |
| 2.7.1.2.1 | ActiveXScriptTask Namespace | 237 |
| 2.7.1.2.1.1 | ActiveXScriptTaskData Element | 237 |
| 2.7.1.2.1.1.1 | ActiveXScriptTaskDataType | 237 |
| 2.7.1.2.1.1.1.1 | ScriptingLanguageEnum | 238 |
| 2.7.1.3 | ASDdlDataObjectDataType | 238 |
| 2.7.1.4 | ASProcessingDataObjectDataType | 239 |
| 2.7.1.5 | BulkInsertTaskData Element | 240 |
| 2.7.1.5.1 | BulkInsertTask Namespace | 240 |
| 2.7.1.5.1.1 | BulkInsertTaskData Element | 240 |
| 2.7.1.5.1.1.1 | BulkInsertTaskDataType | 240 |
| 2.7.1.5.1.1.1.1 | DataFileTypeEnum | 242 |
| 2.7.1.5.1.1.1.2 | CodePageType | 243 |
| 2.7.1.5.1.1.1.3 | BulkInsertTaskTerminatorEnum | 244 |
| 2.7.1.6 | DMQueryTaskDataObjectDataType | 244 |
| 2.7.1.6.1 | DMQueryTaskQueryStringContainerType | 246 |
| 2.7.1.6.2 | DMQueryBuilderSpecificationType | 246 |
| 2.7.1.7 | DataProfilingTaskDataObjectDataType | 247 |
| 2.7.1.7.1 | Data Profiling ProfileInput String Format Definition | 248 |
| 2.7.1.7.1.1 | DataProfile Root Element of the ProfileInput String | 248 |
| 2.7.1.7.1.1.1 | DataSourcesType | 249 |
| 2.7.1.7.1.1.2 | DataProfileInputType | 249 |
| 2.7.1.7.1.1.2.1 | ProfileModeType | 250 |
| 2.7.1.7.1.1.2.2 | ProfileRequest Element | 250 |
| 2.7.1.7.1.1.2.2.1 | ProfileRequestType | 250 |
| 2.7.1.7.1.1.2.2.2 | Elements That Can Be Substituted for the ProfileRequest Element | 251 |
| 2.7.1.7.1.1.2.2.3 | Abstract Base Types Used by Data Profiling Task | 261 |
| 2.7.1.7.1.1.2.2.4 | Other Types Used by Data Profiling Task | 262 |
| 2.7.1.7.1.1.3 | DataProfileOutputType | 265 |
| 2.7.1.7.1.1.3.1 | ProfilesType | 266 |
| 2.7.1.8 | Exec80PackageTaskData Element | 266 |
| 2.7.1.8.1 | Exec80PackageTask Namespace | 266 |
| 2.7.1.8.1.1 | Exec80PackageTaskData Element | 266 |
| 2.7.1.8.1.1.1 | Exec80PackageTaskType | 267 |
| 2.7.1.8.1.1.1.1 | Exec80PackageTaskEnum | 268 |
| 2.7.1.9 | ExecutePackageTaskObjectDataType | 268 |

| | | |
|---------------------|--|-----|
| 2.7.1.10 | ExecuteProcessDataObjectDataType | 269 |
| 2.7.1.10.1 | WindowStyleEnum | 271 |
| 2.7.1.11 | SqlTaskData Element | 272 |
| 2.7.1.11.1 | SQLTask Namespace | 272 |
| 2.7.1.11.1.1 | SqlTaskData Element | 272 |
| 2.7.1.11.1.1.1 | SqlTaskDataType | 272 |
| 2.7.1.11.1.1.1.1 | SqlTaskDatabaseSelectionTypeEnum | 274 |
| 2.7.1.11.1.1.1.2 | SqlTaskTimeUnitsTypeEnum | 275 |
| 2.7.1.11.1.1.1.3 | SelectedDatabasesType | 276 |
| 2.7.1.11.1.1.1.4 | OperatorNotifyListType | 276 |
| 2.7.1.11.1.1.1.5 | SqlTaskParameterBindingType | 276 |
| 2.7.1.11.1.1.1.5.1 | ParameterDirectionEnum | 277 |
| 2.7.1.11.1.1.1.6 | BackupDestinationListType | 277 |
| 2.7.1.11.1.1.1.7 | SqlTaskResultBindingType | 278 |
| 2.7.1.11.1.1.1.8 | SqlTaskBaseAttributeGroup | 278 |
| 2.7.1.11.1.1.1.8.1 | SqlResultTypeEnum | 279 |
| 2.7.1.11.1.1.1.9 | MaintenanceTaskBaseAttributeGroup | 280 |
| 2.7.1.11.1.1.1.10 | BackupTaskAttributeGroup | 281 |
| 2.7.1.11.1.1.1.10.1 | BackupActionEnum | 283 |
| 2.7.1.11.1.1.1.10.2 | BackupDeviceTypeEnum | 284 |
| 2.7.1.11.1.1.1.10.3 | DestinationTypeEnum | 284 |
| 2.7.1.11.1.1.1.10.4 | BackupActionForExistingBackupsEnum | 285 |
| 2.7.1.11.1.1.1.10.5 | BackupCompressionActionEnum | 285 |
| 2.7.1.11.1.1.1.11 | CheckIntegrityTaskAttributeGroup | 286 |
| 2.7.1.11.1.1.1.12 | AgentJobTaskAttributeGroup | 286 |
| 2.7.1.11.1.1.1.13 | HistoryCleanupTaskAttributeGroup | 287 |
| 2.7.1.11.1.1.1.14 | MaintenanceFileCleanupTaskAttributeGroup | 288 |
| 2.7.1.11.1.1.1.14.1 | SqlTaskFileTypeSelectedEnum | 289 |
| 2.7.1.11.1.1.1.15 | NotifyOperatorTaskAttributeGroup | 290 |
| 2.7.1.11.1.1.1.16 | RebuildIndexTaskAttributeGroup | 290 |
| 2.7.1.11.1.1.1.17 | ReorganizeIndexTaskAttributeGroup | 291 |
| 2.7.1.11.1.1.1.18 | ShrinkDBTaskAttributeGroup | 292 |
| 2.7.1.11.1.1.1.19 | UpdateStatisticsTaskAttributeGroup | 293 |
| 2.7.1.11.1.1.1.19.1 | SqlTaskUpdateStatisticsTypeEnum (1) | 293 |
| 2.7.1.11.1.1.1.19.2 | SqlTaskUpdateStatisticsTypeEnum (2) | 294 |
| 2.7.1.11.1.1.1.20 | Execute TSQL Task | 294 |
| 2.7.1.12 | FileSystemDataObjectDataType | 295 |
| 2.7.1.12.1 | FileSystemTaskOperationTypeEnum | 296 |
| 2.7.1.12.2 | FileSystemTaskFileAttributesEnum | 297 |
| 2.7.1.13 | FtpDataObjectDataType | 297 |
| 2.7.1.13.1 | FtpDataTaskOperationTypeEnum | 299 |
| 2.7.1.14 | MessageQueueTaskData Element | 300 |
| 2.7.1.14.1 | MessageQueueTask Namespace | 300 |
| 2.7.1.14.1.1 | MessageQueueTaskData Element | 300 |
| 2.7.1.14.1.1.1 | MessageQueueTaskType | 300 |
| 2.7.1.14.1.1.1.1 | MSMQStringCompareTypeEnum | 303 |
| 2.7.1.14.1.1.1.2 | MSMQTaskTypeEnum | 304 |
| 2.7.1.14.1.1.1.3 | MSMQMessageTypeEnum | 304 |
| 2.7.1.14.1.1.1.4 | MSMQEncryptionAlgorithmEnum | 304 |
| 2.7.1.15 | ScriptProjectObjectDataType | 305 |
| 2.7.1.15.1 | ScriptProjectProjectItemType | 306 |
| 2.7.1.15.2 | ScriptProjectBinaryItemType | 307 |
| 2.7.1.15.3 | ScriptProjectBreakpointType | 307 |
| 2.7.1.15.4 | ScriptProjectLanguageEnum | 308 |
| 2.7.1.15.5 | ScriptProjectHitCountTypeEnum | 309 |
| 2.7.1.15.6 | ScriptProjectConditionTypeEnum | 309 |
| 2.7.1.16 | SendMailTaskData Element | 310 |
| 2.7.1.16.1 | SendMailTask Namespace | 310 |

| | | |
|------------------|---|-----|
| 2.7.1.16.1.1 | SendMailTaskData Element | 310 |
| 2.7.1.16.1.1.1 | SendMailTaskType | 310 |
| 2.7.1.16.1.1.1.1 | AttachmentsElementType | 311 |
| 2.7.1.16.1.1.1.2 | SendMailPriorityEnum | 311 |
| 2.7.1.17 | TransferDatabaseTaskDataObjectDataType | 312 |
| 2.7.1.17.1 | TransferDatabaseTaskActionEnum | 313 |
| 2.7.1.17.2 | TransferDatabaseTaskMethodEnumType | 314 |
| 2.7.1.18 | TransferErrorMessagesTaskDataObjectDataType | 314 |
| 2.7.1.19 | TransferJobsTaskDataObjectDataType | 315 |
| 2.7.1.20 | TransferLoginsTaskDataObjectDataType | 316 |
| 2.7.1.20.1 | TransferLoginsTaskLoginsToTransferEnum | 317 |
| 2.7.1.21 | TransferStoredProceduresTaskDataObjectDataType | 317 |
| 2.7.1.22 | TransferSqlServerObjectsTaskDataObjectDataType | 318 |
| 2.7.1.22.1 | TransferSqlServerObjectsTaskExistingDataEnum | 324 |
| 2.7.1.23 | WebServiceTaskData | 325 |
| 2.7.1.23.1 | WebServiceTask | 325 |
| 2.7.1.23.1.1 | WebServiceTaskData | 325 |
| 2.7.1.23.1.1.1 | WSTaskDataType | 325 |
| 2.7.1.23.1.1.1.1 | WebServiceTaskDataMethodInfoType | 326 |
| 2.7.1.23.1.1.1.2 | WebServiceTaskDataParamInfoType | 327 |
| 2.7.1.23.1.1.1.3 | WebServiceTaskDataOutputTypeEnum | 328 |
| 2.7.1.24 | WMIDRTaskDataObjectDataType | 328 |
| 2.7.1.24.1 | WMITaskDataOverwriteDestinationEnum | 329 |
| 2.7.1.24.2 | WMITaskDataOutputTypeEnum | 330 |
| 2.7.1.25 | WMIEWTaskDataObjectDataType | 330 |
| 2.7.1.25.1 | WMIEWTaskDataActionAtEventEnum | 331 |
| 2.7.1.25.2 | WMIEWTaskDataAfterEventEnum | 332 |
| 2.7.1.25.3 | WMIEWTaskDataActionAtTimeoutEnum | 332 |
| 2.7.1.26 | XMLTaskDataObjectDataType | 333 |
| 2.7.1.26.1 | XMLTaskOperationTypeEnum | 335 |
| 2.7.1.26.2 | XMLTaskDiffOptionsType | 336 |
| 2.7.1.26.3 | XMLTaskDiffAlgorithmEnum | 337 |
| 2.7.1.26.4 | XMLTaskXPathOperationEnum | 337 |
| 2.7.1.26.5 | XMLTaskValidationTypeEnum | 337 |
| 2.8 | Other Types for Package and Non-Package Executables | 338 |
| 2.8.1 | PropertyElementBaseType | 338 |
| 2.8.1.1 | DtsDataTypeEnum | 339 |
| 2.8.2 | PropertyExpressionElementType | 340 |
| 2.8.3 | LoggingOptionsType | 341 |
| 2.8.3.1 | LoggingOptionsPropertyElementType | 342 |
| 2.8.3.1.1 | LoggingOptionsPropertyNameEnum | 343 |
| 2.8.3.1.1.1 | Property Name=LoggingMode | 343 |
| 2.8.3.1.1.2 | Property Name=FilterKind | 344 |
| 2.8.3.1.1.3 | Property Name=ColumnFilter | 344 |
| 2.8.3.2 | SelectedLogProviderType | 345 |
| 2.8.4 | VariableType | 345 |
| 2.8.4.1 | VariablePropertyNameEnum | 347 |
| 2.8.4.1.1 | Property Name=EvaluateAsExpression | 348 |
| 2.8.4.1.2 | Property Name=ReadOnly | 348 |
| 2.8.4.1.3 | Property Name=RaiseChangedEvent | 348 |
| 2.8.4.1.4 | Property Name=IncludeInDebugDump | 349 |
| 2.8.5 | EventHandlerType | 349 |
| 2.8.5.1 | EventHandlerPropertyNameEnum | 351 |
| 2.8.5.1.1 | Property Name=EventName | 351 |
| 2.8.6 | PrecedenceConstraintType | 352 |
| 2.8.6.1 | PrecedenceConstraintExecutableReferenceType | 353 |
| 2.8.6.2 | PrecedenceConstraintPropertyNameEnum | 354 |
| 2.8.6.2.1 | Property Name=EvalOp | 355 |

| | | |
|-----------|---|------------|
| 2.8.6.2.2 | Property Name=LogicalAnd..... | 355 |
| 2.8.6.2.3 | Property Name=Value..... | 355 |
| 2.9 | Enumeration Types and Supporting Types..... | 356 |
| 2.9.1 | BasePropertyNameEnum..... | 356 |
| 2.9.2 | BaseExecutablePropertyNameEnum..... | 356 |
| 2.9.2.1 | Property Name=ISOLevel..... | 358 |
| 2.9.2.2 | Property Name=TransactionOption..... | 358 |
| 2.9.2.3 | Property Name=ForceExecutionResult..... | 359 |
| 2.9.2.4 | Property Name=ForceExecValue..... | 359 |
| 2.9.2.5 | Property Name=Disabled..... | 359 |
| 2.9.2.6 | Property Name=FailPackageOnFailure..... | 360 |
| 2.9.2.7 | Property Name=FailParentOnFailure..... | 360 |
| 2.9.2.8 | Property Name=DelayValidation..... | 360 |
| 2.9.3 | AllExecutablePropertyNameEnum..... | 361 |
| 2.9.3.1 | Property Name=DisableEventHandlers..... | 361 |
| 2.9.4 | UUID..... | 361 |
| 2.9.5 | PasswordElementType..... | 362 |
| 2.9.6 | SourceTypeEnum..... | 362 |
| 2.9.7 | IfObjectExistsEnum..... | 363 |
| 2.9.8 | DestinationTypeEnum..... | 363 |
| 2.9.9 | InnerObjectObjectType..... | 364 |
| 2.10 | Custom Packages..... | 364 |
| 2.10.1 | Custom Executable..... | 365 |
| 2.10.1.1 | ExecutableObjectType Type Replacement..... | 365 |
| 2.10.2 | Custom ConnectionManager..... | 365 |
| 2.10.2.1 | ConnectionManagerObjectType Type Replacement..... | 365 |
| 2.10.3 | Custom Log Provider..... | 366 |
| 2.10.4 | Custom ForEachEnumerator..... | 366 |
| 2.10.4.1 | ForEachEnumeratorObjectType Type Replacement..... | 366 |
| 2.10.5 | Custom Component..... | 367 |
| 2.10.5.1 | PipelineComponentComponentClassIDEnum Type Replacement..... | 367 |
| 2.10.5.2 | PipelineComponentPropertyNameEnum Type Replacement..... | 367 |
| 2.10.5.3 | PipelineComponentInputPropertyNameEnum Type Replacement..... | 367 |
| 2.10.5.4 | PipelineComponentOutputPropertyNameEnum Type Replacement..... | 368 |
| 2.10.5.5 | PipelineComponentInputColumnPropertyNameEnum Type Replacement..... | 368 |
| 2.10.5.6 | PipelineComponentOutputColumnPropertyNameEnum Type Replacement..... | 369 |
| 3 | Structure Examples..... | 370 |
| 3.1 | Lookup and Fuzzy Lookup Components with Error Output..... | 370 |
| 3.2 | Web Service Task and Script Task..... | 400 |
| 3.3 | Custom Component..... | 418 |
| 4 | Security..... | 437 |
| 4.1 | Security Considerations for Implementers..... | 437 |
| 4.1.1 | Encryption Implementation for Settings in the ProtectionLevel Property..... | 437 |
| 4.1.1.1 | Encryption with User Key..... | 437 |
| 4.1.1.2 | Encryption with Password..... | 437 |
| 4.2 | Index of Security Fields..... | 437 |
| 5 | Appendix A: Full DTSX XSD..... | 439 |
| 5.1 | DTS XSD..... | 439 |
| 5.2 | WebServiceTask XSD..... | 485 |
| 5.3 | MessageQueueTask XSD..... | 486 |
| 5.4 | SendMailTask XSD..... | 488 |
| 5.5 | ActiveXScriptTask XSD..... | 488 |
| 5.6 | Exec80PackageTask XSD..... | 489 |
| 5.7 | BulkInsertTask XSD..... | 490 |
| 5.8 | SQLTask XSD..... | 492 |
| 6 | Appendix B: Product Behavior..... | 502 |

| | | |
|----------|------------------------------|------------|
| 7 | Change Tracking | 508 |
| 8 | Index | 509 |

1 Introduction

The Data Transformation Services Package XML (DTSX) file format is an XML-based file format that stores the instructions for the processing of a data flow, including transformations and optional processing steps, from its points of origin to its points of destination.

Sections 1.7 and 2 of this specification are normative. All other sections and examples in this specification are informative.

1.1 Glossary

This document uses the following terms:

bcp utility: A Microsoft SQL Server utility that bulk copies data in a user-specified format between an instance of SQL Server and a data file. The bcp utility can be used to import large numbers of new rows into SQL Server tables or to export data out of tables into data files.

BSTR: A binary structure that contains a string. The structure consists of a length prefix, a character string, and a terminator character.

executable: A unit of executable code that performs a defined task along the data flow in a package.

expression: A combination of symbols (identifiers, literals, functions, and operators) that yields a single data value.

globally unique identifier (GUID): A term used interchangeably with **universally unique identifier (UUID)** in Microsoft protocol technical documents (TDs). Interchanging the usage of these terms does not imply or require a specific algorithm or mechanism to generate the value. Specifically, the use of this term does not imply or require that the algorithms described in [\[RFC4122\]](#) or [\[C706\]](#) must be used for generating the **GUID**. See also **universally unique identifier (UUID)**.

indirect method: A method by which a configuration file is identified by having a Windows environment variable contain the path to the configuration file, instead of storing the path to the file within the package file itself.

inferred member: A member of an Analysis Services dimension whose existence can be inferred from a fact table but which has not yet been loaded from the dimension.

INI file: A configuration file that is used by Windows programs to initialize program settings.

inner variable: A DTS 2000 variable that is of package scope to a DTS 2000 Package when that package is executed by a parent Microsoft SQL Server Integration Services (SSIS) package. The inner variable is passed in to the DTS 2000 package from a parent Integration Services package.

language code identifier (LCID): A 32-bit number that identifies the user interface human language dialect or variation that is supported by an application or a client computer.

Microsoft Message Queuing (MSMQ): A communications service that provides asynchronous and reliable message passing between distributed applications. In **Message Queuing**, applications send messages to queues and consume messages from queues. The queues provide persistence of the messages, enabling the sending and receiving applications to operate asynchronously from one another.

outer variable: An Integration Services package-scope variable that is passed into a DTS 2000 package. Inside the DTS 2000 package, it becomes an inner variable.

package file: A file that contains a collection of tasks that form a workflow that is executed in the order that is defined within the package, with possible conditional branching.

package variable: A special type of variable within a package file that contains information about the last state of the screen layout of the package. Package variables are used by the user interface when a new session to modify a package is started.

passive mode: An FTP mode in which the client initiates a conversation by connection to the FTP server port, and the client also initiates the data communication port connection, to a port specified by the server in its initial response to the client. For more information about FTP active mode and passive mode, see [\[MSKB-323446\]](#).

precedence constraint: An object in a Integration Services package that controls the order of execution of tasks or the condition under which a task executes.

Server Management Objects (SMO) Server: An instance of SQL Server that is accessed through calls to the Server Management Objects (SMO) object model.

Simple Mail Transfer Protocol (SMTP): A member of the TCP/IP suite of protocols that is used to transport Internet messages, as described in [\[RFC5321\]](#).

tag table: A table that is used in the column pattern profile option of the Data Profiling Task. This table contains a list of tags that are used to tag specific terms that are found in the data file.

task: The building block of a package. A task consists of code that executes a function, as specified by the options, settings, and parameters of the task that are specified when the task is called.

TFIDF Score: One of the options for producing a similarity score used by the Term Extraction Component. The TFIDF score is defined as the TFIDF of a Term T = (frequency of T) * log((# rows in Input) / (# rows having T)).

Transact-SQL: The Microsoft proprietary version of SQL, the structured query language.

Unicode: A character encoding standard developed by the Unicode Consortium that represents almost all of the written languages of the world. The **Unicode** standard [\[UNICODE5.0.0/2007\]](#) provides three forms (UTF-8, UTF-16, and UTF-32) and seven schemes (UTF-8, UTF-16, UTF-16 BE, UTF-16 LE, UTF-32, UTF-32 LE, and UTF-32 BE).

universally unique identifier (UUID): A 128-bit value. UUIDs can be used for multiple purposes, from tagging objects with an extremely short lifetime, to reliably identifying very persistent objects in cross-process communication such as client and server interfaces, manager entry-point vectors, and RPC objects. UUIDs are highly likely to be unique. UUIDs are also known as **globally unique identifiers (GUIDs)** and these terms are used interchangeably in the Microsoft protocol technical documents (TDs). Interchanging the usage of these terms does not imply or require a specific algorithm or mechanism to generate the UUID. Specifically, the use of this term does not imply or require that the algorithms described in [\[RFC4122\]](#) or [\[C706\]](#) must be used for generating the UUID.

variable: One of the objects that is in a package file. A variable allows a package designer to assign a value to a symbolic name, which can then be accessed by other package objects.

Windows Management Instrumentation (WMI): The Microsoft implementation of Common Information Model (CIM), as specified in [\[DMTF-DSP0004\]](#). WMI allows an administrator to manage local and remote machines and models computer and network objects using an extension of the CIM standard.

XPathNavigator: An object that allows navigation of the set of objects that are returned by an XPATH query.

MAY, SHOULD, MUST, SHOULD NOT, MUST NOT: These terms (in all caps) are used as defined in [\[RFC2119\]](#). All statements of optional behavior use either MAY, SHOULD, or SHOULD NOT.

1.2 References

Links to a document in the Microsoft Open Specifications library point to the correct section in the most recently published version of the referenced document. However, because individual documents in the library are not updated at the same time, the section numbers in the documents may not match. You can confirm the correct section numbering by checking the [Errata](#).

1.2.1 Normative References

We conduct frequent surveys of the normative references to assure their continued availability. If you have any issue with finding a normative reference, please contact dochelp@microsoft.com. We will assist you in finding the relevant information.

[ECMA-327] ECMA, "ECMAScript 3rd Edition Compact Profile", Standard ECMA-327, June 2001, <http://www.ecma-international.org/publications/standards/Ecma-327.htm>

[ISO/IEC8859-1] ISO/IEC, "Information technology -- 8-bit single-byte coded graphic character sets - Part 1: Latin alphabet No. 1", ISO/IEC 8859-1:1998, April 1998, http://www.iso.org/iso/home/store/catalogue_tc/catalogue_detail.htm?csnumber=28245

Note There is a charge to download the specification.

[JavaSpec] Oracle Technology Network, "The Java Language Specification, Third Edition", January 2005, <http://docs.oracle.com/javase/specs/jls/se6/html/j3TOC.html>

[RFC2119] Bradner, S., "Key words for use in RFCs to Indicate Requirement Levels", BCP 14, RFC 2119, March 1997, <http://www.rfc-editor.org/rfc/rfc2119.txt>

[RFC2268] Rivest, R., "A Description of the RC2(r) Encryption Algorithm", RFC 2268, March 1998, <http://www.rfc-editor.org/rfc/rfc2268.txt>

[RFC2459] Housley, R., Ford, W., Polk, W., and Solo, D., "Internet X.509 Public Key Infrastructure Certificate and CRL Profile", RFC 2459, January 1999, <http://www.rfc-editor.org/rfc/rfc2459.txt>

[UNICODE] The Unicode Consortium, "The Unicode Consortium Home Page", <http://www.unicode.org/>

[US-ASCII] Columbia University, "The US ASCII Character Set", 1986, <http://www.columbia.edu/kermit/ascii.html>

[XML10/5] Bray, T., Paoli, J., Sperberg-McQueen, C.M., et al., Eds., "Extensible Markup Language (XML) 1.0 (Fifth Edition)", W3C Recommendation, November 2008, <http://www.w3.org/TR/2008/REC-xml-20081126/>

[XMLNS] Bray, T., Hollander, D., Layman, A., et al., Eds., "Namespaces in XML 1.0 (Third Edition)", W3C Recommendation, December 2009, <http://www.w3.org/TR/2009/REC-xml-names-20091208/>

[XMLSCHEMA1/2] Thompson, H., Beech, D., Maloney, M., and Mendelsohn, N., Eds., "XML Schema Part 1: Structures Second Edition", W3C Recommendation, October 2004, <http://www.w3.org/TR/2004/REC-xmlschema-1-20041028/>

[XMLSCHEMA2/2] Biron, P., and Malhotra, A., Eds., "XML Schema Part 2: Datatypes Second Edition", W3C Recommendation, October 2004, <http://www.w3.org/TR/2004/REC-xmlschema-2-20041028/>

[XPath] Clark, J. and DeRose, S., "XML Path Language (XPath), Version 1.0", W3C Recommendation, November 1999, <http://www.w3.org/TR/1999/REC-xpath-19991116/>

1.2.2 Informative References

[Haselden] Haselden, K., "Microsoft SQL Server 2005 Integration Services", Sams, 2006, ISBN: 0672327813.

[MSDN-ADONETSRC] Microsoft Corporation, "ADO NET Source", <https://docs.microsoft.com/en-us/sql/integration-services/data-flow/ado-net-source>

[MSDN-BCPU] Microsoft Corporation, "bcp Utility", [https://docs.microsoft.com/en-us/previous-versions/sql/sql-server-2008-r2/ms162802\(v=sql.105\)](https://docs.microsoft.com/en-us/previous-versions/sql/sql-server-2008-r2/ms162802(v=sql.105))

[MSDN-C#LS] Microsoft Corporation, "C# Language Specification", <https://docs.microsoft.com/en-us/dotnet/csharp/language-reference/language-specification/>

[MSDN-CryptProtectData] Microsoft Corporation, "CryptProtectData Function", <https://docs.microsoft.com/en-us/windows/desktop/api/dpapi/nf-dpapi-cryptprotectdata>

[MSDN-DMXR] Microsoft Corporation, "Data Mining Extensions (DMX) Reference", <https://docs.microsoft.com/en-us/sql/dmx/data-mining-extensions-dmx-reference>

[MSDN-EPCO] Microsoft Corporation, "Extending Packages with Custom Objects", <https://docs.microsoft.com/en-us/sql/integration-services/extending-packages-custom-objects/extending-packages-with-custom-objects>

[MSDN-MMASDM] Microsoft Corporation, "Mining Models (Analysis Services - Data Mining)", <https://docs.microsoft.com/en-us/sql/analysis-services/data-mining/mining-models-analysis-services-data-mining>

[MSDN-MSASDM] Microsoft Corporation, "Mining Structures (Analysis Services - Data Mining)", <https://docs.microsoft.com/en-us/sql/analysis-services/data-mining/mining-structures-analysis-services-data-mining>

[MSDN-PBCO] Microsoft Corporation, "Performing Bulk Copy Operations", <https://docs.microsoft.com/en-us/sql/relational-databases/native-client/features/performing-bulk-copy-operations>

[MSDN-POS] Microsoft Corporation, "Processing Options and Settings (Analysis Services)", <https://docs.microsoft.com/en-us/sql/analysis-services/multidimensional-models/processing-options-and-settings-analysis-services>

[MSDN-TYPCLS] Microsoft Corporation, "Type Class", <https://docs.microsoft.com/en-us/dotnet/api/system.type>

[MSDN-VBLR] Microsoft Corporation, "Visual Basic Language Reference", <https://docs.microsoft.com/en-us/dotnet/visual-basic/language-reference/index>

[MSDN-VBSLR] Microsoft Corporation, "VBScript Language Reference", [https://docs.microsoft.com/en-us/previous-versions/d1wf56tt\(v=vs.85\)](https://docs.microsoft.com/en-us/previous-versions/d1wf56tt(v=vs.85))

[SCAN-RC4] Rivest, R., "Symmetric Cyphers: RC4 Stream Cipher", September 1994, <http://www.users.zetnet.co.uk/hopwood/crypto/scan/cs.html#RC4>

[XMLEncSynProc] Imamura, T., Dillaway, B., Simon, E., et al., "XML Encryption Syntax and Processing Version 1.1", W3C Recommendation, April 2013, <http://www.w3.org/TR/xmlenc-core/>

1.3 Overview

This document describes the persistence file structure for the Microsoft SQL Server Integration Services (SSIS) product. Integration Services is a tool that is used to orchestrate activities to move

and conform data from disparate sources in an enterprise into a convenient location and shape, often for analysis and reporting. The DTSX structure describes these orchestration activities as a set of pathways that are comprised of a set of steps, each of which can involve processing of the data as it flows through the step. Collectively, these steps form the control flow of the package.

The steps, each of which is an **executable**, can be conditional or iterative. Some executables are containers for other executables, and some of these containers are define looping within the control flow. Not all of the steps that are described in the document are necessarily executed on any one execution of the control flow. The DTSX structure allows the user to specify a Data Flow **task** that modifies and/or transforms the data.

The structure also allows the ability to define pathways for the data with conditional elements that can change the transformations through which particular pieces of data pass and the final destinations to which these pieces of data are routed.

A file that conforms to the DTSX structure as defined in this document can be processed by the data transformation processing engine, or it can be opened in a user interface to make modifications to the definition.

The following diagram shows one typical use of Integration Services: to consolidate a data flow from multiple sources, and while consolidating, also transform and assure consistency of all the data.

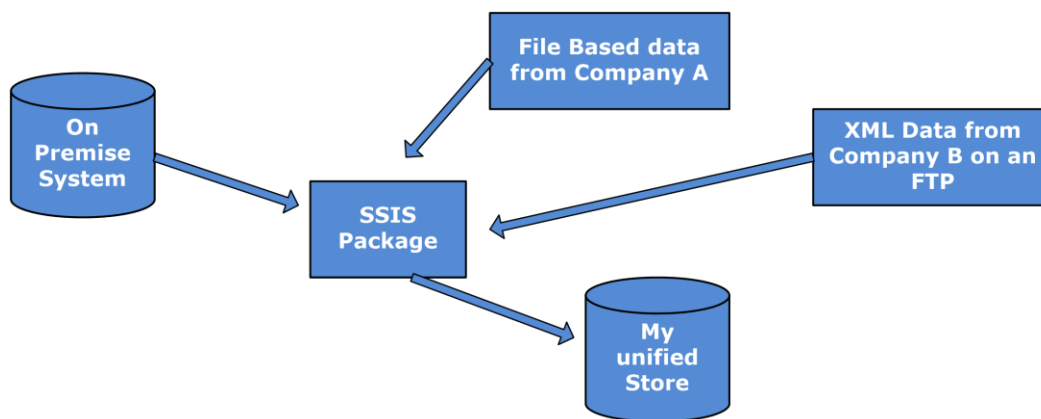

Figure 1: Integration Services package data flow

The intermediate step in the data flow can be one of the following:

- **Executable Task:** Performs a defined type of work along the control flow. Custom tasks can be written by end users to perform any task that is not included with the Integration Services product. Examples of standard tasks that ship with the Integration Services product are manipulating an external file, processing Microsoft SQL Server Analysis Services objects, running a data mining query, performing file transfers with FTP, performing a database backup, and executing an external executable.
- **Component:** Components perform data transformations along the data flow. Examples of components that ship with the Integration Services product are components that: perform aggregations; create columns derived by a specified formula; and perform row counts, sampling, and lookups. End users can also create custom components to perform additional transformations that are not included with the standard product.

The following diagram is a detailed example of a data flow described by the DTSX structure format. The diagram shows the presence of two data sources (an OLE DB Source and a Flat File Source) and three final data destinations (a Raw File Destination, an OLE DB Destination, and a SQL Server Destination). The steps in the data flow, based on conditional processing, determine which destination

the data ultimately flows to and how it is transformed and processed on the route to its final destination.

Some of the intermediate steps are conditional. For example, there are two arrows between Lookup and Fuzzy Lookup. One arrow represents the data flow for erroneous data, and the other arrow represents flow for standard output.

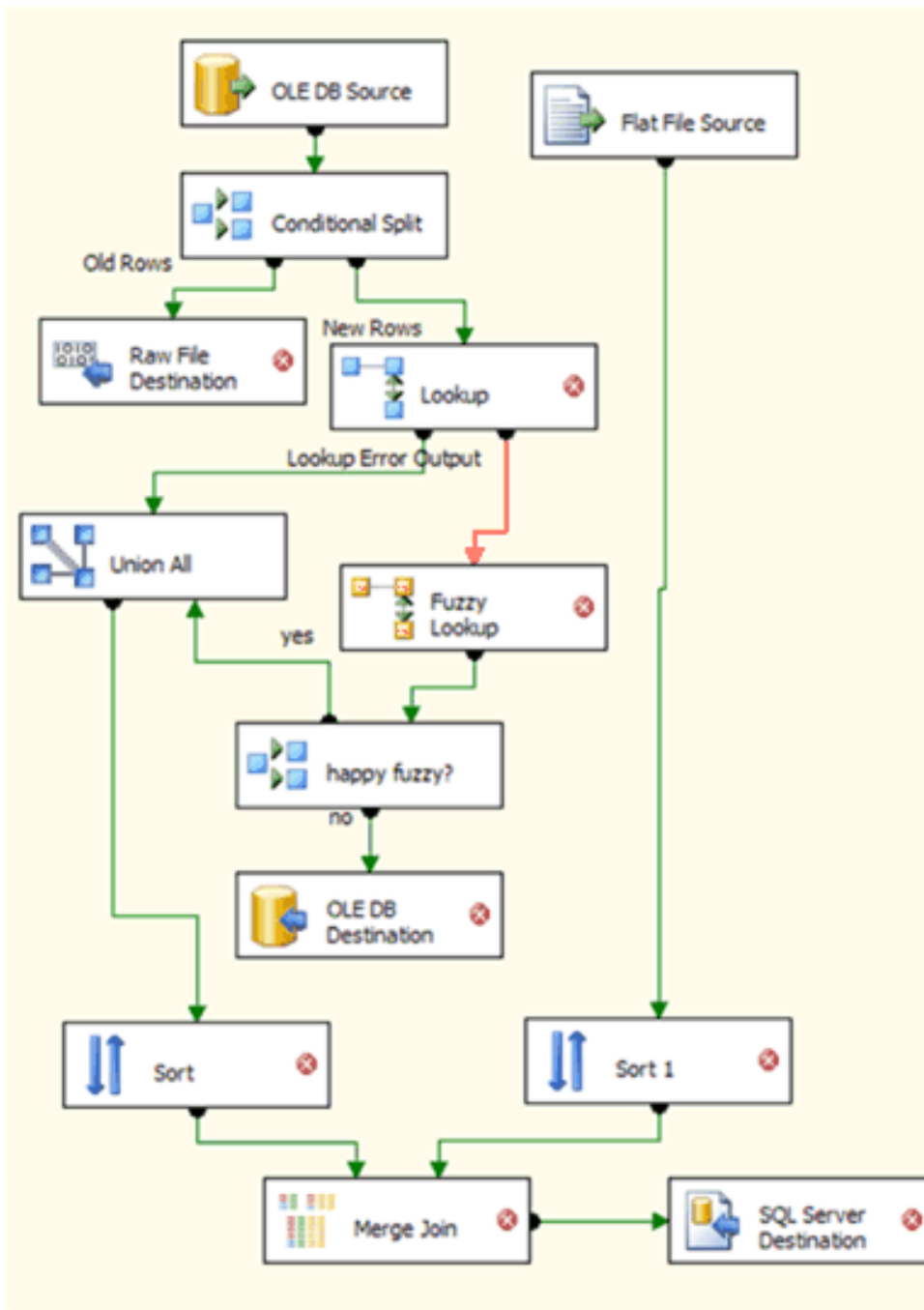

Figure 2: Data flow described by DTSX structure

1.4 Relationship to Protocols and Other Structures

The usual structure format is clear-text XML [\[XML10/5\]](#).

1.5 Applicability Statement

This document describes an XML-based file persistence format that is used to describe a data flow that can be processed by a processing engine.

1.6 Versioning and Localization

Structure Versions: There are no version-dependent structures in the DTSX file format.

Localization: There are no localization-dependent structures in the DTSX file format.

1.7 Vendor-Extensible Fields

The DTSX structure allows for vendor extensibility. Vendors can add custom-programmed objects of the following types to the system and therefore to the DTSX structure.

- Executable
- ConnectionManager
- Log Provider
- ForEachEnumerator
- Component

The following table lists the affected elements, attributes, properties, or types for each of the above cases.

| Custom item | Reference | Elements, attributes, properties, or types |
|-------------------|--|---|
| Executable | Custom Executable | <ul style="list-style-type: none">▪ ObjectData element |
| ConnectionManager | Custom ConnectionManager | <ul style="list-style-type: none">▪ ObjectData element |
| LogProvider | Custom Log Provider | None |
| ForEachEnumerator | Custom ForEachEnumerator | <ul style="list-style-type: none">▪ ObjectData element |
| Component | Custom Component | <ul style="list-style-type: none">▪ PipelineComponentComponentClassIDEnum type▪ PipelineComponentPropertyNameEnum type▪ PipelineComponentInputPropertyNameEnum type▪ PipelineComponentOutputPropertyNameEnum type▪ PipelineComponentInputColumnPropertyNameEnum type▪ PipelineComponentOutputColumnPropertyNameEnum type |

2 Structures

This section contains the definition of the DTSX structure. DTSX structure instances are contained in a single file called a **package file**.

The usual structure format is clear-text XML [\[XML10/5\]](#). The XML MAY be encrypted. [<1>](#) XML schemas are used to describe the DTSX structure [\[XMLSCHEMA1/2\]](#) [\[XMLSCHEMA2/2\]](#).

2.1 Additional Normative Requirements Concerning the XSD Fragments Provided

2.1.1 Constraints beyond the XSD Definitions for Complex Types

Each section of the structure definition has an accompanying XSD to define the type for a particular element of the structure. However, in some cases, there are additional constraints on what can be contained in a defined element that go beyond what is expressed in the XSD. These constraints MUST be followed. Any such constraints for each complex type are noted in the tables and information that accompany the XSD within each section.

2.1.2 `<xs:sequence>` Usage Expressed in the XSD is Optional

Throughout this structure definition, the `<xs:sequence>` XSD construct is used. [<2>](#)

2.2 Namespaces

This specification defines and references various XML namespaces using the mechanisms that are specified in [\[XMLNS\]](#). Although this specification associates a specific XML namespace prefix for each XML namespace that is used, the choice of any particular XML namespace prefix is implementation-specific and is not significant for interoperability.

| Prefix | Namespace URI | Reference |
|-------------------|---|-----------------------------|
| DTS | www.microsoft.com/SqlServer/Dts | Section 5.1 |
| WSTask | www.microsoft.com/sqlserver/dts/tasks/webservicetask | Section 5.2 |
| MessageQueueTask | www.microsoft.com/sqlserver/dts/tasks/messagequeuetask | Section 5.3 |
| SendMailTask | www.microsoft.com/sqlserver/dts/tasks/sendmailtask | Section 5.4 |
| ActiveXScriptTask | www.microsoft.com/sqlserver/dts/tasks/activexscripttask | Section 5.5 |
| Exec80PackageTask | www.microsoft.com/sqlserver/dts/tasks/exec80packagetask | Section 5.6 |
| BulkInsertTask | www.microsoft.com/sqlserver/dts/tasks/bulkinserttask | Section 5.7 |
| SQLTask | www.microsoft.com/sqlserver/dts/tasks/sqltask | Section 5.8 |

2.3 Executable Element

All Microsoft SQL Server Integration Services (SSIS) packages MUST contain a single root element. This element is the **Executable** element. The root **Executable** element MUST be of type **DTS:ExecutableTypePackage**.

The following is the XSD for the **Executable** root element.

```
<xs:element name="Executable" type="DTS:ExecutableTypePackage"/>
```

2.4 ExecutableTypePackage

The **ExecutableTypePackage** complex type defines the content of the [Executable](#) root element.

The following is the XSD definition for the **ExecutableTypePackage** complex type.

```
<xs:complexType name="ExecutableTypePackage">
  <xs:sequence>
    <xs:element name="Property" maxOccurs="unbounded">
      <xs:complexType>
        <xs:complexContent>
          <xs:extension base="DTS:PropertyElementBaseType">
            <xs:attribute name="Name"
              type="DTS:ExecutableTypePackagePropertyNameEnum"
              use="required"/>
          </xs:extension>
        </xs:complexContent>
      </xs:complexType>
    </xs:element>
    <xs:element name="ConnectionManager" type="DTS:ConnectionManagerType"
      minOccurs="0" maxOccurs="unbounded"/>
    <xs:element name="Configuration" type="DTS:ConfigurationType"
      minOccurs="0" maxOccurs="unbounded"/>
    <xs:element name="LogProvider" type="DTS:LogProviderType"
      minOccurs="0" maxOccurs="unbounded"/>
    <xs:element name="Variable" type="DTS:VariableType"
      maxOccurs="unbounded"/>
    <xs:element name="LoggingOptions" type="DTS:LoggingOptionsType" />
    <xs:element name="PropertyExpression"
      type="DTS:PropertyExpressionElementType"
      minOccurs="0" maxOccurs="unbounded"/>
    <xs:element name="Executable" type="DTS:AnyNonPackageExecutableType"
      minOccurs="0" maxOccurs="unbounded"/>
    <xs:element name="PrecedenceConstraint"
      type="DTS:PrecedenceConstraintType"
      minOccurs="0" maxOccurs="unbounded"/>
    <xs:element name="EventHandler" type="DTS:EventHandlerType"
      minOccurs="0" maxOccurs="unbounded"/>
    <xs:element name="PackageVariable" type="DTS:PackageVariableType"
      minOccurs="0" maxOccurs="unbounded"/>
  </xs:sequence>
  <xs:attribute name="ExecutableType" use="required"
    fixed="SSIS.Package.2" />
</xs:complexType>
```

The following table provides additional information about the elements and types in the **ExecutableTypePackage** complex type.

| Element | Constraints | Type definition | Description |
|-----------------|--|------------------------------------|--|
| Property | In some cases, constraints are placed on the Property element's value for specific values of the Name attribute of the Property element. If such constraints exist, they are specified where the meaning of the particular property name is specified. These constraints MUST be followed. If the optional Data Type attribute is present, the value of the Property | Inline in the XSD in this section. | Specifies values for many different properties associated with an instance of the containing Executable |

| Element | Constraints | Type definition | Description |
|---------------------------|---|---|--|
| | element MUST be of the type indicated by the DataType attribute. | | element, according to the Name attribute of each Property element. |
| ConnectionManager | None. | ConnectionManagerType | Specifies information about the data connections that are available to this package. |
| Configuration | None. | ConfigurationType | Specifies configuration information for the package. |
| LogProvider | None. | LogProviderType | Specifies the destination to which logging data is output. |
| Variable | None. | VariableType | Specifies definitions of variables that can be defined in the package. |
| LoggingOptions | None. | LoggingOptionsType | Specifies information about what kind of information is logged for this package and where it is recorded. |
| PropertyExpression | Additional constraints exist for the PropertyExpression element. For a description of these constraints, see PropertyExpressionElementType . | PropertyExpressionElementType | Serves the same purpose as specified for the Property element except that an expression that is evaluated at run time is contained in the element's value. |
| Executable | None. | AnyNonPackageExecutableType | Specifies the |

| Element | Constraints | Type definition | Description |
|-----------------------------|-------------|--|--|
| | | | executables that are contained in this package |
| PrecedenceConstraint | None. | PrecedenceConstraintType | Specifies information about precedence constraints between contained executables in this package. |
| EventHandler | None. | EventHandlerType | Specifies event handlers for this package. |
| PackageVariable | None. | PackageVariableType | Specifies definitions of package variables for this package. |

The following table provides additional information about the attributes and types in the **ExecutableTypePackage** complex type.

| Attribute | Constraints | Description |
|-----------------------|-------------|---|
| ExecutableType | None. | Specifies information about the contents of the Executable element on which the attribute value appears. |

The following table provides additional information about the attributes and types for the **Property** element that is declared inline in the complex type declaration. The **Property** element is an extension of the **PropertyElementBaseType** type with the addition of the **Name** attribute, which is specified in the following table.

| Attribute | Constraints | Description |
|-------------|-------------|---|
| Name | None. | Specifies the Name of the Property element. Each named property has its own use and interpretation. The explanation for the interpretation of each named property is given with the definition of the type for the Name attribute. |

2.4.1 PackageVariableType

The **PackageVariableType** complex type is used to specify package variables. Package variables are used to save screen information so that the Microsoft SQL Server Integration Services (SSIS) user interface editor can present the screen for editing in the same state as it was left in.

The following is the XSD for the **PackageVariableType** complex type.

```
<xs:complexType name="PackageVariableType">
```

```

<xs:sequence>
  <xs:element name="Property"
    maxOccurs="unbounded">
    <xs:complexType>
      <xs:complexContent>
        <xs:extension base="DTS:PropertyElementBaseType">
          <xs:attribute name="Name"
            type="DTS:PackageVariablePropertyNameEnum"
            use="required"/>
        </xs:extension>
      </xs:complexContent>
    </xs:complexType>
  </xs:element>
  <xs:element name="PropertyExpression"
    type="DTS:PropertyExpressionElementType"
    minOccurs="0" maxOccurs="unbounded"/>
</xs:sequence>
</xs:complexType>

```

The following table provides additional information about the elements, types, and constraints in the **PackageVariableType** complex type.

| Element | Additional constraints | Type definition | Description |
|---------------------------|--|------------------------------------|---|
| Property | In some cases, constraints are placed on the Property element's value for specific values of the Name attribute of the Property element. If such constraints exist, they are specified where the meaning of the particular property name is specified. These constraints MUST be followed. If the optional DataType attribute is present, the value of the Property element MUST be of the type that is specified by the DataType attribute. | Inline in the XSD in this section. | Property elements contain values for many different properties associated with an instance of the containing Executable element, according to the Name attribute of each Property element. |
| PropertyExpression | Additional constraints exist for the PropertyExpression element. For a description of these constraints, see PropertyExpressionElementTy pe . | PropertyExpressionElementType | The PropertyExpressi on element serves the same purpose as specified for the Property element, except that an expression that is evaluated at run time is contained in the element's value that is stored in the Integration Services file format. |

The following table provides additional information about the attributes and types for the **Property** element that is declared inline in the complex type declaration. The **Property** element is an extension of the [PropertyElementBaseType](#) type with the addition of the **Name** attribute, which is specified in the following table.

| Attribute | Constraints | Description |
|-------------|-------------|--|
| Name | None. | Specifies the name of the property. Each named property has its own use and interpretation. The meaning of each named property is given with the definition of the type for the Name attribute. |

2.4.1.1 PackageVariablePropertyNameEnum

The **PackageVariablePropertyNameEnum** type contains the values for the **Name** attribute of the property elements that are allowed for the [PackageVariableType](#) complex type.

The following is the XSD for the **PackageVariablePropertyNameEnum** type.

```
<xs:simpleType name="PackageVariablePropertyNameEnum">
  <xs:union memberTypes="DTS:BasePropertyNameEnum">
    <xs:simpleType>
      <xs:restriction base="xs:string">
        <xs:enumeration value="PackageVariableValue"/>
        <xs:enumeration value="PackageVariable"/>
        <xs:enumeration value="Namespace"/>
      </xs:restriction>
    </xs:simpleType>
  </xs:union>
</xs:simpleType>
```

The following table specifies the enumeration values for the **PackageVariablePropertyNameEnum** type. The **PackageVariablePropertyNameEnum** type is a union of the [BasePropertyNameEnum](#) type with the values that are specified in the following table. The values described in this table do not include the values already specified for the **BasePropertyNameEnum** type.

| Property name | Description |
|-----------------------------|--|
| PackageVariableValue | The PackageVariableValue enumeration value specifies that the element contains text that specifies screen locations for visual design of packages. It is not in the scope of this document to describe the interpretation of this text. |
| PackageVariable | The PackageVariable enumeration value is a synonym for PackageVariableValue . |
| Namespace | The Namespace enumeration value specifies that the element value contains an additional qualifier that enables unique identification of a package variable. Two package variables with the same name can be distinguished by having a different Namespace value. |

2.4.2 ConfigurationType

The **ConfigurationType** complex type contains configuration information that is accessed by other elements within the package.

The following is the XSD for the **ConfigurationType** complex type.

```
<xs:complexType name="ConfigurationType">
  <xs:sequence>
    <xs:element name="Property"
      maxOccurs="unbounded">
```

```

<xs:complexType>
  <xs:complexContent>
    <xs:extension base="DTS:PropertyElementBaseType">
      <xs:attribute name="Name"
        type="DTS:ConfigurationPropertyNameEnum"
        use="required"/>
    </xs:extension>
  </xs:complexContent>
</xs:complexType>
</xs:element>
<xs:element name="PropertyExpression"
  type="DTS:PropertyExpressionElementType"
  minOccurs="0" maxOccurs="unbounded"/>
</xs:sequence>
</xs:complexType>

```

The following table provides additional information about the elements, types, and constraints in the **ConfigurationType** complex type.

| Element | Additional constraints | Type definition | Description |
|---------------------------|--|------------------------------------|--|
| Property | In some cases, constraints are placed on the Property element's value for specific values of the Name attribute of the Property element. If such constraints exist, they are specified where the meaning of the particular property name is specified. These constraints MUST be followed. If the optional Data Type attribute is present, the value of the Property element MUST be of the type that is specified by the Data Type attribute. | Inline in the XSD in this section. | Property elements contain values for many different properties that are associated with an instance of the containing ConfigurationType element, according to the Name attribute of each Property element. |
| PropertyExpression | Additional constraints exist for the PropertyExpression element. For a description of the constraints, see PropertyExpressionElementType . | PropertyExpressionElementType | The PropertyExpression element serves the same purpose as described for the Property element, except that an expression that is evaluated at run time is contained in the element's value that is stored in the Microsoft SQL Server Integration Services (SSIS) file format. |

The following table provides additional information about the attributes and types for the **Property** element that is declared inline in the complex type declaration. The **Property** element is an extension of the [PropertyElementBaseType](#) type with the addition of the **Name** attribute, which is specified in the following table.

| Attribute | Constraints | Description |
|-------------|-------------|--|
| Name | None | Specifies the name of the property. Each named property has its own use and interpretation. The meaning of each named property is given with the definition of the type for the Name attribute. |

2.4.2.1 ConfigurationPropertyNameEnum

The **ConfigurationPropertyNameEnum** type contains the values for the **Name** attribute of the property elements that are allowed for the [ConfigurationType](#) complex type.

The following is the XSD for the **ConfigurationPropertyNameEnum**.

```
<xs:simpleType name="ConfigurationPropertyNameEnum">
  <xs:union memberTypes="DTS:BasePropertyNameEnum">
    <xs:simpleType>
      <xs:restriction base="xs:string">
        <xs:enumeration value="ConfigurationType"/>
        <xs:enumeration value="ConfigurationString"/>
        <xs:enumeration value="ConfigurationVariable"/>
      </xs:restriction>
    </xs:simpleType>
  </xs:union>
</xs:simpleType>
```

The following table specifies the enumeration values for the **ConfigurationPropertyNameEnum** type. The **ConfigurationPropertyNameEnum** type is a union of the [BasePropertyNameEnum](#) type with the additional values that are specified in this table. The values that are specified in this table do not include the values already specified for **BasePropertyNameEnum**.

| Property name | Description |
|------------------------------|---|
| ConfigurationType | The source from which the configuration is read. For additional restrictions, see Property Name=ConfigurationType . |
| ConfigurationString | The element contains a string value that is used to institute the configuration. The use of the string varies with the setting for ConfigurationType . |
| ConfigurationVariable | The full path, within the package, to the property that is being configured. |

2.4.2.1.1 Property Name=ConfigurationType

When the **Property** element's **Name** attribute value is **ConfigurationType**, the values that are allowed for the **Property** element are more restricted than the values that are specified by the XSD type definition for the **Property** element of the [ConfigurationType](#) type.

In this case, the allowed values for the **Property** element value MUST be one of the values in the following table.

| Element value | Object that the configuration is retrieved from |
|---------------|---|
| 0 | A parent variable . |
| 1 | A configuration file. |

| Element value | Object that the configuration is retrieved from |
|---------------|---|
| 2 | An environment variable. |
| 3 | A registry entry. |
| 4 | A parent variable, indirect method . |
| 5 | A configuration file, indirect method. |
| 6 | A registry entry, indirect method. |
| 7 | A database table. |
| 8 | An INI file . |
| 9 | Database Server, indirect method. |
| 10 | An INI file, indirect method. |

2.4.3 LogProviderType

The **LogProviderType** complex type is used to define a particular log provider that is used by the package.

The following is the XSD for the **LogProviderType** complex type.

```
<xs:complexType name="LogProviderType" >
  <xs:sequence>
    <xs:element name="Property"
      maxOccurs="unbounded">
      <xs:complexType>
        <xs:complexContent>
          <xs:extension base="DTS:PropertyElementBaseType">
            <xs:attribute name="Name"
              type="DTS:LogProviderPropertyNameEnum"
              use="required"/>
          </xs:extension>
        </xs:complexContent>
      </xs:complexType>
    </xs:element>
    <xs:element name="PropertyExpression"
      type="DTS:PropertyExpressionElementType"
      minOccurs="0" maxOccurs="unbounded"/>
    <xs:element name="ObjectData" type="DTS:LogProviderObjectDataType"/>
  </xs:sequence>
</xs:complexType>
```

The following table provides additional information about the elements, types, and constraints in the **LogProviderType** complex type.

| Element | Additional constraints | Type definition | Description |
|-----------------|---|------------------------------------|--|
| Property | In some cases, constraints are placed on the Property element's value for specific values of the Name attribute of the Property element. If such constraints exist, they | Inline in the XSD in this section. | Property elements contain values for many different properties associated with an instance of the containing |

| Element | Additional constraints | Type definition | Description |
|---------------------------|--|---|--|
| | are specified where the meaning of the particular property name is specified. These constraints MUST be followed. If the optional DataType attribute is present, the value of the Property element MUST be of the type that is specified by the DataType attribute. | | Executable element, according to the Name attribute of each Property element. |
| PropertyExpression | Additional constraints exist for the PropertyExpression element. For a description of these constraints, see PropertyExpressionElementType . | PropertyExpressionElementType | The PropertyExpression element serves the same purpose as specified for the Property element, except that an expression that is evaluated at runtime is contained in the element's value that is stored in the Microsoft SQL Server Integration Services (SSIS) file format. |
| ObjectData | None. | LogProviderObjectDataType | Contains information that is specific to the LogProvider . For more information, see Executable ObjectData Types . |

The following table provides additional information about the attributes and types for the **Property** element that is declared inline in the complex type declaration. The **Property** element is an extension of the [PropertyElementBaseType](#) type with the addition of the **Name** attribute, which is specified in the following table.

| Attribute | Constraints | Description |
|-------------|-------------|--|
| Name | None. | Specifies the name of the Property element. Each named property has its own use and interpretation. The explanation for the interpretation of each named property is given with the definition of the type for the Name attribute. |

2.4.3.1 LogProviderPropertyNameEnum

The **LogProviderPropertyNameEnum** type contains the values for the **Name** attribute of the property elements that are allowed for the [LogProviderType](#) complex type.

The following is the XSD for the **LogProviderPropertyNameEnum** type.

```
<xs:simpleType name="LogProviderPropertyNameEnum">
  <xs:union memberTypes="DTS:BasePropertyNameEnum">
    <xs:simpleType>
      <xs:restriction base="xs:string">
        <xs:enumeration value="DelayValidation"/>
        <xs:enumeration value="ConfigString"/>
      </xs:restriction>
    </xs:simpleType>
  </xs:union>
</xs:simpleType>
```



```

        </xs:restriction>
    </xs:simpleType>
</xs:union>
</xs:simpleType>

```

The following table specifies the enumeration values for the **LogProviderPropertyNameEnum** type. The **LogProviderPropertyNameEnum** type is a union of the [BasePropertyNameEnum](#) type with the additional values that are specified in the following table. The values that are specified in this table do not include the values that are already specified for **BasePropertyNameEnum**.

| Property name | Description |
|------------------------|---|
| DelayValidation | Specifies whether validation is delayed until the Executable element that contains this LogProvider executes. For additional restrictions, see Property Name=DelayValidation . |
| ConfigString | Set to a value that is used by each specific log provider in a different way. |

2.4.3.1.1 Property Name=DelayValidation

When the **Property** element's **Name** attribute value is **DelayValidation**, the values that are allowed for the **Property** element are more restricted than the values that are specified by the XSD type definition for the **Property** element of the [LogProviderType](#) type.

In this case, the allowed values for the **Property** element value MUST be the values in the following table.

| Element value | Description |
|---------------|--|
| 1 | TRUE. The validation of the LogProvider is delayed until the container is executed. |
| 0 | FALSE. The validation of the LogProvider is not delayed until run time. |

2.4.3.2 LogProviderObjectType

The **LogProviderObjectType** complex type provides information that is specific to a particular instance of a **LogProvider** element.

The following is the XSD for the **LogProviderObjectType** complex type.

```

<xs:complexType name="LogProviderObjectType">
  <xs:sequence>
    <xs:element name="InnerObject" form="unqualified"
      type="DTS:InnerObjectObjectType"/>
  </xs:sequence>
</xs:complexType>

```

| Element | Additional constraints | Type definition | Description |
|--------------------|------------------------|------------------------------------|---|
| InnerObject | None. | Inline in the XSD in this section. | Can contain additional information that is specific to an instance of a LogProvider element. <3> |

2.4.4 ConnectionManagerType

The **ConnectionManagerType** complex type is used to specify a connection to a data source.

The following is the XSD of the **ConnectionManagerType** complex type.

```
<xs:complexType name="ConnectionManagerType">
  <xs:sequence>
    <xs:element name="Property"
      maxOccurs="unbounded">
      <xs:complexType>
        <xs:complexContent>
          <xs:extension base="DTS:PropertyElementBaseType">
            <xs:attribute name="Name"
              type="DTS:ConnectionManagerPropertyNameEnum"
              use="required"/>
          </xs:extension>
        </xs:complexContent>
      </xs:complexType>
    </xs:element>
    <xs:element name="PropertyExpression"
      type="DTS:PropertyExpressionElementType"
      minOccurs="0" maxOccurs="unbounded"/>
    <xs:element name="ObjectData"
      type="DTS:ConnectionManagerObjectDataType"/>
  </xs:sequence>
</xs:complexType>
```

The following table provides additional information about the elements, types, and constraints for the **ConnectionManagerType** complex type.

| Element | Additional constraints | Type definition | Description |
|---------------------------|--|------------------------------------|---|
| Property | In some cases, constraints are placed on the Property element's value for specific values of the Name attribute of the Property element. If such constraints exist, they are specified where the meaning of the particular property name is specified. These constraints MUST be followed. If the optional DataType attribute is present, the value of the Property element MUST be of the type that is specified by the DataType attribute. | Inline in the XSD in this section. | Property elements contain values for many different properties that are associated with an instance of the containing Executable element, according to the Name attribute of each Property element. |
| PropertyExpression | Additional constraints exist for the PropertyExpression element. For a description of these constraints, see PropertyExpressionElementTy pe . | PropertyExpressionElementype | The PropertyExpression element serves the same purpose as specified for the Property element, except that an expression that is evaluated at run time is contained in the element's value that is stored in the Microsoft SQL Server Integration Services (SSIS) file format. Properties contained in the ObjectData element can also become |

| Element | Additional constraints | Type definition | Description |
|-------------------|--|---------------------------------|--|
| | | | PropertyExpressions in this location. |
| ObjectData | The contents of the ObjectData element vary with the data source that the ConnectionManager element is specifying. For more information about data sources, see ConnectionManagerObjectData Type . | ConnectionManagerObjectDataType | Contains information that is specific to the containing ConnectionManager element. The nature of the information varies with the type of data that the connection manager is connecting to, which is specified by the CreationName property. |

The following table provides additional information about the attributes and types for the **Property** element that is declared inline in the complex type declaration. The **Property** element is an extension of the [PropertyElementBaseType](#) type with the addition of the **Name** attribute, which is specified in the following table.

| Attribute | Constraints | Description |
|-------------|-------------|--|
| Name | None. | Specifies the name of the Property element. Each named property has its own use and interpretation. The explanation for the interpretation of each named property is given with the definition of the type for the Name attribute. |

2.4.4.1 ConnectionManagerPropertyNameEnum

The **ConnectionManagerPropertyNameEnum** type contains the values for the **Name** attribute of the property elements that are allowed for the [ConnectionManagerType](#) complex type.

The following is the XSD for the **ConnectionManagerPropertyNameEnum** type.

```
<xs:simpleType name="ConnectionManagerPropertyNameEnum">
  <xs:union memberTypes="DTS:BasePropertyNameEnum">
    <xs:simpleType>
      <xs:restriction base="xs:string">
        <xs:enumeration value="DelayValidation"/>
      </xs:restriction>
    </xs:simpleType>
  </xs:union>
</xs:simpleType>
```

The following table specifies the enumeration values for the **ConnectionManagerPropertyNameEnum** type. The **ConnectionManagerPropertyNameEnum** type is a union of the [BasePropertyNameEnum](#) type with the additional values that are specified in this section. The values that are specified in this table do not include the values that are already specified for **BasePropertyNameEnum**.

| Property name | Description |
|------------------------|---|
| DelayValidation | Specifies whether validation is delayed until the container of this ConnectionManager executes. For additional restrictions, see Property Name=DelayValidation . |

2.4.4.1.1 Property Name=DelayValidation

When the **Property** element's **Name** attribute value is **DelayValidation**, the values that are allowed for the **Property** element are more restricted than the values that are specified by the XSD type definition for the **Property** element of the [ConnectionManagerType](#) type.

In this case, the allowed values for the **Property** element value MUST be one of the values in the following table.

| Element value | Description |
|---------------|--|
| 1 | TRUE. The validation of the ConnectionManager is delayed until the container is executed. |
| 0 | FALSE. The validation of the ConnectionManager is not delayed until run time. |

2.4.4.2 ConnectionManagerObjectDataType

The **ConnectionManagerObjectDataType** complex type is used to contain additional information that is specific to each type of data connection that is not expressed in the **Property** elements of a **ConnectionManager** instance.

The following is the XSD of the **ConnectionManagerObjectDataType** complex type.

```
<xs:complexType name="ConnectionManagerObjectDataType">
  <xs:choice>
    <xs:element name="ConnectionManager" type=
      "DTS:ConnectionManagerObjectDataConnectionManagerType"/>
    <xs:element name="MsmqConnectionManager" type=
      "DTS:ConnectionManagerObjectDataMsmqConnectionManagerType"
      form="unqualified"/>
    <xs:element name="SMOServerConnectionManager" type=
      "DTS:ConnectionManagerObjectDataSMOServerConnectionManagerType"
      form="unqualified"/>
    <xs:element name="SmtpConnectionManager" type=
      "DTS:ConnectionManagerObjectDataSmtpConnectionManagerType"
      form="unqualified"/>
    <xs:element name="WmiConnectionManager" type=
      "DTS:ConnectionManagerObjectDataWmiConnectionManagerType"
      form="unqualified"/>
  </xs:choice>
</xs:complexType>
```

The following table provides additional information about the elements, types, and constraints in the **ConnectionManagerObjectDataType** complex type.

| Element | Additional constraints | Type definition | Description |
|-------------------------------|---|--|--|
| ConnectionM anager | Depending on the type of the connection, there are limits on what can be placed in the ConnectionManager element. These constraints MUST be followed. For more information, see ConnectionManagerObjectDataConnectionManagerType . Depending on the type of the connection, there are constraints on the allowed values for the Name | ConnectionManagerObjectDataConnectionManagerType | Contains information for the following connection types: <ul style="list-style-type: none"> ▪ OLE DB ▪ Flat File ▪ ADO.NET ▪ Analysis Services |

| Element | Additional constraints | Type definition | Description |
|-----------------------------------|---|---|---|
| | attribute of the Property elements that are contained in the ConnectionManager element. These constraints MUST be followed. For more information, see ConnectionManagerObjectDataPropertyNameEnum . | | <ul style="list-style-type: none"> ▪ File ▪ Cache ▪ Excel ▪ FTP ▪ HTTP ▪ Multi-file ▪ Multiple flat file ▪ Open Database Connectivity (ODBC) ▪ SQL Server Mobile |
| MsmqConnectionManager | None. | ConnectionManagerObjectDataMsmqConnectionManagerType | Contains information that is specific to the Microsoft Message Queuing (MSMQ) ConnectionManager type. |
| SMOServerConnectionManager | None. | ConnectionManagerObjectDataSMOServerConnectionManagerType | Contains information that is specific to the Server Management Objects (SMO) Server ConnectionManager type. |
| SmtplibConnectionManager | None. | ConnectionManagerObjectDataSmtplibConnectionManagerType | Contains information that is specific to the Simple Mail Transfer Protocol (SMTP) ConnectionManager type. |
| WmiConnectionManager | None. | ConnectionManagerObjectDataWmiConnectionManagerType | Contains information that is specific to the Windows Management Instrumentation (WMI) ConnectionManager type. |

2.4.4.2.1 ConnectionManagerObjectDataConnectionManagerType

The **ObjectData** element in the **ConnectionManager** contains a **ConnectionManager** element of type **ConnectionManagerObjectDataConnectionManagerType** when the data source is one of the following:

- OLE DB
- Flat File

- ADO.NET
- Analysis Services
- File
- Cache
- Excel
- FTP
- HTTP
- Multi-file
- Multiple Flat File
- ODBC
- SQL Server Mobile

The following is the XSD of the **ConnectionManagerObjectDataConnectionManagerType** type.

```
<xs:complexType
  name="ConnectionManagerObjectDataConnectionManagerType">
  <xs:sequence>
    <xs:element name="Property"
      minOccurs="0" maxOccurs="unbounded">
      <xs:complexType>
        <xs:complexContent>
          <xs:extension base="DTS:PropertyElementBaseType">
            <xs:attribute name="Name"
              type="DTS:ConnectionManagerObjectDataPropertyNameEnum"
              use="required"/>
          </xs:extension>
        </xs:complexContent>
      </xs:complexType>
    </xs:element>
    <xs:choice minOccurs="0">
      <xs:element name="FlatFileColumn" type="DTS:FlatFileColumnType"
        maxOccurs="unbounded"/>
      <xs:element name="CacheColumn" type="DTS:CacheColumnType"
        maxOccurs="unbounded"/>
      <xs:element name="FtpConnection" type="DTS:FtpConnectionType"/>
      <xs:element name="HttpConnection" type="DTS:HttpConnectionType"/>
    </xs:choice>
  </xs:sequence>
</xs:complexType>
```

The following table provides additional information about the elements, types, and constraints for the **ConnectionManagerType** complex type.

| Element | Additional constraints | Type definition | Description |
|-----------------|--|------------------------------------|--|
| Property | In some cases, constraints are placed on the Property element's value for specific values of the Name attribute of the Property element. If such constraints exist, they are specified where the meaning of the particular property name is specified. These constraints MUST be followed. If the optional Data Type attribute is present, the value of the Property element MUST be of | Inline in the XSD in this section. | Property elements contain values for many different properties that are associated with an instance of the containing Executable |

| Element | Additional constraints | Type definition | Description |
|-----------------------|--|------------------------------------|---|
| | the type that is specified by the DataType attribute. | | element, according to the Name attribute of each Property element. |
| FlatFileColumn | The FlatFileColumn element MUST NOT appear unless the data source for the ConnectionManager is a flat file or is multiple flat files. The FlatFileColumn element MUST be included if the data source for the ConnectionManager is a flat file or is multiple flat files. | FlatFileColumnType | Contains the definition of a flat file column that is present in the data source. |
| CacheColumn | The CacheColumn element MUST NOT appear unless the data source for the ConnectionManager is a Cache data source. The CacheColumn element MUST be included if the data source is Cache data. | CacheColumnType | Contains the definition of a cache column that is present in the data source. |
| FtpConnection | The FtpConnection element MUST NOT appear unless the data source for the ConnectionManager is an FTP data source. The FtpConnection element MUST be included if the data source is an FTP data source. | FtpConnectionType | Contains the properties of an FTP connection. |
| HttpConnection | The HttpConnection element MUST NOT appear unless the data source for the ConnectionManager is an HTTP data source. The HttpConnection element MUST be included if the data source is an HTTP data source. | HttpConnectionType | Contains the properties of an HTTP connection. |

The following table provides additional information about the attributes and types for the **Property** element that is declared inline in the complex type declaration. The **Property** element is an extension of the [PropertyElementBaseType](#) type with the addition of the **Name** attribute, which is specified in the following table.

| Attribute | Constraints | Description |
|-------------|-------------|--|
| Name | None. | Specifies the name of the Property element. Each named property has its own use and interpretation. The explanation for the interpretation of each named property is given with the definition of the type for the Name attribute. |

2.4.4.2.1.1 ConnectionManagerObjectDataPropertyNameEnum

The **ConnectionManagerObjectDataPropertyNameEnum** type contains the values for the **Name** attribute of the **Property** elements that are allowed for the [ConnectionManagerObjectType](#) complex type.

The following is the XSD for the **ConnectionManagerPropertyNameEnum** type.

```
<xs:simpleType name="ConnectionManagerObjectDataPropertyNameEnum">
  <xs:restriction base="xs:string">
    <xs:enumeration value="Retain"/>
    <xs:enumeration value="ConnectionString"/>
    <xs:enumeration value="FileUsageType"/>
    <xs:enumeration value="Format"/>
    <xs:enumeration value="LocaleID"/>
  </xs:restriction>
</xs:simpleType>
```

```

<xs:enumeration value="Unicode"/>
<xs:enumeration value="HeaderRowsToSkip"/>
<xs:enumeration value="HeaderRowDelimiter"/>
<xs:enumeration value="ColumnNamesInFirstDataRow"/>
<xs:enumeration value="RowDelimiter"/>
<xs:enumeration value="DataRowsToSkip"/>
<xs:enumeration value="TextQualifier"/>
<xs:enumeration value="CodePage"/>
<xs:enumeration value="ServerName"/>
<xs:enumeration value="UseFile"/>
<xs:enumeration value="UseEncryption"/>
<xs:enumeration value="RetainData"/>
</xs:restriction>
</xs:simpleType>

```

The following table specifies the enumeration values for the **ConnectionManagerObjectDataPropertyNameEnum** type.

| Enumeration value | Description |
|----------------------------------|---|
| Retain | Specifies whether the same connection is retained between successive data accesses. For additional restrictions, see Property Name=Retain . |
| ConnectionString | Specifies a string value that is handed to the data source upon connection. The contents of the string vary with the source type. |
| FileUsageType | Specifies how the file connection is used. For additional restrictions, see Property Name=FileUsageType . |
| Format | Specifies the type of formatting in the records and fields of a file. For additional restrictions, see Property Name=Format . |
| LocaleID | Specifies that the element value contains the language code identifier (LCID) for the language for the ConnectionManager . |
| Unicode | Specifies an indicator for whether the data source contains Unicode characters. For additional restrictions, see Property Name=Unicode . |
| HeaderRowsToSkip | Specifies that the element value contains an integer that represents the number of header rows to skip in the data source. |
| HeaderRowDelimiter | Specifies that the element value contains a hexadecimal-encoded value in ASCII [US-ASCII] for the character or character string that is the delimiter for the header row. Each such character MUST be prepended and postpended with an underscore character (_). For example, the string "_x000D__x000A_" specifies the sequence of characters as a carriage return character followed by a line feed character. |
| ColumnNamesInFirstDataRow | Specifies that the element value contains an indicator for whether the first row contains column names. For additional restrictions, see Property Name=ColumnNamesInFirstDataRow . |
| RowDelimiter | Specifies the row delimiter. <4> |
| DataRowsToSkip | Specifies that the element value contains an integer that specifies the number of data rows to skip. |
| TextQualifier | Specifies a character that is used to indicate text values. |
| CodePage | Specifies that the element value is the numeric value of the ANSI code page that is used for strings. |
| ServerName | Specifies that the Property element value contains the name of the server |

| Enumeration value | Description |
|----------------------|---|
| | for the connection. |
| UseFile | Specifies whether the cache is stored. TRUE specifies that the cache is backed by a cache file on disk. FALSE specifies that the cache is stored only in memory and erased when the package terminates. For additional restrictions, see Property Name=UseFile . |
| UseEncryption | Specifies that the Property element value contains an indicator for whether to use encryption for data access. For additional restrictions, see Property Name=UseEncryption . |
| RetainData | Specifies an enumeration value. <5> For additional restrictions, see Property Name=RetainData . |

2.4.4.2.1.1.1 Property Name=Retain

When the **Property** element's **Name** attribute value is **Retain**, the values that are allowed for the **Property** element are more restricted than the values that are specified by the XSD type declaration for the **Property** element of the [ConnectionManagerObjectDataType](#) type.

In this case, the allowed values for the **Property** element value MUST be one of the values in the following table.

| Element value | Description |
|---------------|--|
| 0 | False. Specifies that the Property element does not retain the connection between successive data accesses. |
| -1 | True. Specifies that the Property element retains the connection between successive data accesses. |

2.4.4.2.1.1.2 Property Name=Format

When the **Property** element's **Name** attribute value is **Format**, the values that are allowed for the **Property** element are more restricted than the values that are specified by the XSD type declaration for the **Property** element of the [ConnectionManagerObjectDataType](#) type.

In this case, the allowed values for the **Property** element value MUST be one of the values in the following table.

| Element value | Description |
|--------------------|--|
| Delimited | Specifies that the format of the file contains fields that are delimited with a delimiter. |
| FixedWidth | Specifies that the format of the file contains fields that are of fixed width. |
| RaggedRight | Specifies that the format of the file contains records that can be truncated on the right. |

2.4.4.2.1.1.3 Property Name=Unicode

When the **Property** element's **Name** attribute value is **Unicode**, the values that are allowed for the **Property** element are more restricted than the values that are specified by the XSD type declaration for the **Property** element of the [ConnectionManagerObjectDataType](#) type.

In this case, the allowed values for the **Property** element value MUST be one of the values in the following table.

| Element value | Description |
|---------------|---|
| 0 | False. Specifies that the data obtained from the connection is not Unicode. |
| -1 | True. Specifies that the data obtained from the connection is Unicode. |

2.4.4.2.1.1.4 Property Name=ColumnNamesInFirstDataRow

When the **Property** element's **Name** attribute value is **ColumnNamesInFirstDataRow**, the values that are allowed for the **Property** element are more restricted than the values that are specified by the XSD type declaration for the **Property** element of the [ConnectionManagerObjectDataType](#) type.

In this case, the allowed values for the **Property** element value MUST be one of the values in the following table.

| Element value | Description |
|---------------|---|
| 0 | False. Specifies that the first data row does not contain column names. |
| -1 | True. Specifies that the first data row contains column names. |

2.4.4.2.1.1.5 Property Name=UseFile

When the **Property** element's **Name** attribute value is **UseFile**, the values that are allowed for the **Property** element are more restricted than the values that are specified by the XSD type declaration for the **Property** element of the [ConnectionManagerObjectDataType](#) type.

In this case, the allowed values for the **Property** element value MUST be one of the values in the following table.

| Element value | Description |
|---------------|---|
| 0 | False. Specifies that the connection manager does not use a file. |
| -1 | True. Specifies that the connection manager does use a file. |

2.4.4.2.1.1.6 Property Name=UseEncryption

When the **Property** element's **Name** attribute value is **UseEncryption**, the values that are allowed for the **Property** element are more restricted than the values that are specified by the XSD type declaration for the **Property** element of the [ConnectionManagerObjectDataType](#) type.

In this case, the allowed values for the **Property** element value MUST be one of the values in the following table.

| Element value | Description |
|---------------|---|
| 0 | False. Specifies that the element does do not use encryption. |
| -1 | True. Specifies that the element does use encryption. |

2.4.4.2.1.1.7 Property Name=RetainData

When the **Property** element's **Name** attribute value is **RetainData**, the values that are allowed for the **Property** element are more restricted than the values that are specified by the XSD type declaration for the **Property** element of the [ConnectionManagerObjectType](#) type.

In this case, the allowed values for the **Property** element value MUST be one of the values in the following table.

| Element value | Description |
|---------------|---|
| 0 | False. Specifies that the connectcion manager does not retain data. |
| -1 | True. Specifies that the connectcion manager does retain data. |

2.4.4.2.1.1.8 Property Name=FileUsageType

When the **Property** element's **Name** attribute value is **FileUsageType**, the values that are allowed for the **Property** element are more restricted than the values that are specified by the XSD type declaration for the **Property** element of the [ConnectionManagerObjectType](#) type.

In this case, the allowed values for the **Property** element value MUST be one of the values in the following table.

| Element value | Description |
|---------------|---|
| 0 | Specifies that the file connection manager uses an existing file. |
| 1 | Specifies that the file connection manager creates a file. |
| 2 | Specifies that the file connection manager uses an existing folder. |
| 3 | Specifies that the file connection manager creates a folder. |

2.4.4.2.1.2 FlatFileColumnType

The **FlatFileColumnType** complex type gives the definition of a column that is contained in a flat file data source.

The following is the XSD of the **FlatFileColumnType** complex type.

```
<xs:complexType name="FlatFileColumnType">
  <xs:sequence>
    <xs:element name="Property"
      minOccurs="0" maxOccurs="unbounded">
      <xs:complexType>
        <xs:complexContent>
```

```

    <xs:extension base="DTS:PropertyElementBaseType">
      <xs:attribute name="Name"
        type="DTS:FlatFileColumnPropertyNameEnum"
        use="required"/>
    </xs:extension>
  </xs:complexContent>
</xs:complexType>
</xs:element>
</xs:sequence>
</xs:complexType>

```

The following table provides additional information about the elements, types, and constraints in the **FlatFileColumnType** complex type.

| Element | Additional constraints | Type definition | Description |
|-----------------|--|------------------------------------|---|
| Property | In some cases, constraints are placed on the Property element's value for specific values of the Name attribute of the Property element. If such constraints exist, they are specified where the meaning of the particular property name is specified. These constraints MUST be followed. If the optional DataType attribute is present, the value of the Property element MUST be of the type that is specified by the DataType attribute. | Inline in the XSD in this section. | Property elements contain values for many different properties that are associated with an instance of the containing FlatFileColumn element, according to the Name attribute of each Property element. |

The following table provides additional information about the attributes and types for the **Property** element that is declared inline in the complex type declaration. The **Property** element is an extension of the [PropertyElementBaseType](#) type with the addition of the **Name** attribute, which is specified in the following table.

| Attribute | Constraints | Description |
|-------------|-------------|--|
| Name | None. | Specifies the name of the Property element. Each named property has its own use and interpretation. The explanation for the interpretation of each named property is given with the definition of the type for the Name attribute. |

2.4.4.2.1.2.1 FlatFileColumnPropertyNameEnum

The **FlatFileColumnPropertyNameEnum** type contains the values for the **Name** attribute of the property elements that are allowed for the [FlatFileColumnType](#) type.

The following is the XSD for the **FlatFileColumnPropertyNameEnum** type.

```

<xs:simpleType name="FlatFileColumnPropertyNameEnum">
  <xs:union memberTypes="DTS:BasePropertyNameEnum">
    <xs:simpleType>
      <xs:restriction base="xs:string">
        <xs:enumeration value="ColumnType"/>
        <xs:enumeration value="ColumnDelimiter"/>
        <xs:enumeration value="ColumnWidth"/>
        <xs:enumeration value="MaximumWidth"/>
        <xs:enumeration value="DataType"/>
        <xs:enumeration value="DataPrecision"/>
        <xs:enumeration value="DataScale"/>
        <xs:enumeration value="TextQualified"/>
      </xs:restriction>
    </xs:simpleType>
  </xs:union>
</xs:simpleType>

```

```

    </xs:simpleType>
  </xs:union>
</xs:simpleType>

```

The following table specifies the enumeration values for the **FlatFileColumnPropertyNameEnum** type. The table does not contain the description of the values for the [BasePropertyNameEnum](#).

| Enumeration value | Description |
|------------------------|---|
| ColumnType | The element value contains an indicator for whether the column is delimited or fixed width. For additional restrictions, see Property Name=ColumnType . |
| ColumnDelimiter | A string that contains the column delimiter in the file. |
| ColumnWidth | An integer that contains the width of the column. This value is used if the ColumnTypeProperty value is "FixedWidth". |
| MaximumWidth | An integer that contains the maximum number of bytes to be read from the buffer. |
| DataType | The data type of the column. For additional restrictions, see Property Name=DataType . |
| DataPrecision | An integer that specifies the total digits in a numeric data type. |
| DataScale | The number of digits to the right of the decimal point. |
| TextQualified | The element contains an indicator for whether the column is text qualified. For additional restrictions, see Property Name=TextQualified . |

2.4.4.2.1.2.1.1 Property Name=ColumnType

When the **Property** element's **Name** attribute value is **ColumnType**, the values that are allowed for the **Property** element are more restricted than the values that are specified by the XSD type declaration for the **Property** element of the [FlatFileColumnType](#) type.

In this case, the allowed values for the **Property** element value MUST be one of the values in the following table.

| Element value | Description |
|-------------------|--|
| Delimited | Specifies that the column values are delimited by a delimiter. |
| FixedWidth | Specifies that the column values are of fixed width. |

2.4.4.2.1.2.1.2 Property Name=DataType

When the **Property** element's **Name** attribute value is **DataType**, the values that are allowed for the **Property** element are more restricted than the values that are specified by the XSD type declaration for the **Property** element of the [FlatFileColumnType](#) type.

In this case, the value for the **Property** element value MUST be one of the values that are contained in the [DtsDataTypeEnum](#) type. The descriptions for that type apply here as well.

2.4.4.2.1.2.1.3 Property Name=TextQualified

When the **Property** element's **Name** attribute value is **TextQualified**, the values that are allowed for the **Property** element are more restricted than the values that are specified by the XSD type declaration for the **Property** element of the [FlatFileColumnType](#) type.

In this case, the allowed values for the **Property** element value MUST be one of the values in the following table.

| Element value | Description |
|---------------|---|
| 0 | False. Specifies that the column is not text qualified. |
| -1 | True. Specifies that the column is text qualified. |

2.4.4.2.1.3 CacheColumnType Complex Type

The **CacheColumnType** complex type specifies the definition of a column that is contained in a Cache data source.

The following is the XSD for the **CacheColumnType** complex type.

```
<xs:complexType name="CacheColumnType">
  <xs:sequence>
    <xs:element name="Property"
      minOccurs="0" maxOccurs="unbounded">
      <xs:complexType>
        <xs:complexContent>
          <xs:extension base="DTS:PropertyElementBaseType">
            <xs:attribute name="Name"
              type="DTS:CacheColumnPropertyNameEnum"
              use="required"/>
          </xs:extension>
        </xs:complexContent>
      </xs:complexType>
    </xs:element>
  </xs:sequence>
</xs:complexType>
```

The following table provides additional information about the elements, types, and constraints in the **FlatFileColumnType** complex type.

| Element | Additional constraints | Type definition | Description |
|-----------------|--|------------------------------------|---|
| Property | In some cases, constraints are placed on the Property element's value for specific values of the Name attribute of the Property element. If such constraints exist, they are specified where the meaning of the particular property name is specified. These constraints MUST be followed. If the optional DataType attribute is present, the value of the Property element MUST be of the type indicated by the DataType attribute. | Inline in the XSD in this section. | Property elements contain values for many different properties that are associated with an instance of the containing FlatFileColumn element, according to the Name attribute of each Property element. |

The following table provides additional information about the attributes and types for the **Property** element that is declared inline in the complex type declaration. The **Property** element is an extension of the [PropertyElementBaseType](#) type with the addition of the **Name** attribute, which is specified in the following table.

| Attribute | Constraints | Description |
|-------------|-------------|--|
| Name | None. | Specifies the name of the Property element. Each named property has its own use and interpretation. The explanation for the interpretation of each named property is given with the definition of the type for the Name attribute. |

2.4.4.2.1.3.1 CacheColumnPropertyNameEnum

The **CacheColumnPropertyNameEnum** type contains the values for the **Name** attribute of the property elements that are allowed for the [CacheColumnType](#) complex type.

The following is the XSD for the **CacheColumnPropertyNameEnum** type.

```
<xs:simpleType name="CacheColumnPropertyNameEnum">
  <xs:union memberTypes="DTS:BasePropertyNameEnum">
    <xs:simpleType>
      <xs:restriction base="xs:string">
        <xs:enumeration value="DataType"/>
        <xs:enumeration value="Length"/>
        <xs:enumeration value="Precision"/>
        <xs:enumeration value="Scale"/>
        <xs:enumeration value="CodePage"/>
        <xs:enumeration value="IndexPosition"/>
      </xs:restriction>
    </xs:simpleType>
  </xs:union>
</xs:simpleType>
```

The following table specifies the enumeration values for the **CacheColumnPropertyNameEnum** type. The table does not contain the description of the value for the [BasePropertyNameEnum](#).

| Enumeration value | Description |
|----------------------|--|
| DataType | Specifies the data type of the column. For additional restrictions, see Property Name=DataType . |
| Length | Specifies the length of the cache column in characters. |
| Precision | Specifies an integer that defines the total digits in a numeric data type. |
| Scale | Specifies the number of digits to the right of the decimal point. |
| CodePage | Specifies that the element value is the numeric value of the ANSI code page that is used for strings. |
| IndexPosition | Specifies the index position of the current cache column. |

2.4.4.2.1.4 FtpConnectionType Complex Type

The **FtpConnectionType** type specifies the properties that are necessary to connect to an FTP data source.

The following is the XSD of the **FtpConnectionType** type.

```
<xs:complexType name="FtpConnectionType">
```

```

<xs:sequence>
  <xs:element name="Property"
    minOccurs="0" maxOccurs="unbounded">
    <xs:complexType>
      <xs:complexContent>
        <xs:extension base="DTS:PropertyElementBaseType">
          <xs:attribute name="Name"
            type="DTS:FtpConnectionPropertyNameEnum"
            use="required"/>
          <xs:attribute name="Sensitive" form="unqualified">
            <xs:simpleType>
              <xs:restriction base="xs:int">
                <xs:minInclusive value="0"/>
                <xs:maxInclusive value="1"/>
              </xs:restriction>
            </xs:simpleType>
          </xs:attribute>
          <xs:attribute name="Encrypted" form="unqualified">
            <xs:simpleType>
              <xs:restriction base="xs:int">
                <xs:minInclusive value="0"/>
                <xs:maxInclusive value="1"/>
              </xs:restriction>
            </xs:simpleType>
          </xs:attribute>
        </xs:extension>
      </xs:complexContent>
    </xs:complexType>
  </xs:element>
</xs:sequence>
</xs:complexType>

```

The following table provides additional information about the elements, types, and constraints for the **FtpConnectionType** complex type.

| Element | Additional constraints | Type definition | Description |
|-----------------|--|------------------------------------|--|
| Property | In some cases, constraints are placed on the Property element's value for specific values of the Name attribute of the Property element. If such constraints exist, they are specified where the meaning of the particular property name is specified. These constraints MUST be followed. If the optional Data Type attribute is present, the value of the Property element MUST be of the type that is specified by the Data Type attribute. | Inline in the XSD in this section. | Property elements contain values for many different properties associated with an instance of the containing FlatFileColumn element, according to the Name attribute of each Property element. |

The following table provides additional information about the attributes and types for the **Property** element that is declared inline in the complex type declaration. The **Property** element is an extension of the **PropertyElementBaseType** type with the addition of the attributes that are specified in the following table.

| Attribute | Constraints | Description |
|------------------|-------------|--|
| Name | None. | Specifies the name of the Property element. Each named property has its own use and interpretation. The explanation for the interpretation of each named property is given with the definition of the type for the Name attribute. |
| Sensitive | None. | The element value contains an indicator for whether the property information is treated as sensitive. The integer value has the following meanings: 0 = The property value is not considered to be sensitive. |

| Attribute | Constraints | Description |
|------------------|-------------|--|
| | | 1 = The property value is considered to be sensitive. Depending on the setting of the ProtectionLevel value in an ancestor level to the containing element, the value of the property can or cannot be displayed if the property is considered to be sensitive. |
| Encrypted | None | The attribute value contains an indicator for whether the element value is encrypted. FALSE – Specifies that the element value is not encrypted. TRUE – Specifies that the element value is encrypted. For more details about the encryption algorithm that is used if the value of the Encrypted attribute is TRUE, see section 4 . |

2.4.4.2.1.4.1 FtpConnectionPropertyNameEnum

The **FtpConnectionPropertyNameEnum** type contains the values for the **Name** attribute of the property elements that are allowed for the [FtpConnectionType](#) type.

The following is the XSD for the **FtpConnectionPropertyNameEnum** type.

```
<xs:simpleType name="FtpConnectionPropertyNameEnum">
  <xs:restriction base="xs:string">
    <xs:enumeration value="ServerName"/>
    <xs:enumeration value="ServerPort"/>
    <xs:enumeration value="ServerUserName"/>
    <xs:enumeration value="ServerPassword"/>
    <xs:enumeration value="ChunkSize"/>
    <xs:enumeration value="TimeOut"/>
    <xs:enumeration value="Retries"/>
    <xs:enumeration value="UsePassiveMode"/>
  </xs:restriction>
</xs:simpleType>
```

The following table specifies the enumeration values for the **FtpConnectionPropertyNameEnum** type.

| Enumeration value | Description |
|-----------------------|--|
| ServerName | Specifies a string that contains the name of the FTP server to connect to. |
| ServerPort | Specifies a string that contains the port for the connection. |
| ServerUserName | Specifies a string that contains the user name to use on the FTP server. |
| ServerPassword | Specifies a string that contains the password to use to access the FTP server. |
| ChunkSize | Specifies an integer that contains the minimum number of bytes to receive or send. |
| TimeOut | Specifies an integer that contains the number of seconds to wait before the connection fails. |
| Retries | Specifies an integer that contains the number of times that the FTP connection attempts to send data before the connection fails. |
| UsePassiveMode | Specifies that the element value contains an indicator for whether the FTP connection uses passive mode . For additional restrictions, see Property Name=UsePassiveMode . |

2.4.4.2.1.4.1.1 Property Name=UsePassiveMode

When the **Property** element's **Name** attribute value is **UsePassiveMode**, the values that are allowed for the **Property** element are more restricted than the values that are specified by the XSD type declaration for the **Property** element of the [HttpConnectionType](#) type. In this case, the allowed values for the **Property** element value MUST be one of the values in the following table.

| Element value | Description |
|---------------|---|
| 0 | False. Specifies that active mode is used for the FTP connection. |
| -1 | True. Specifies that passive mode is used for the FTP connection. |

2.4.4.2.1.5 HttpConnectionType Complex Type

The **HttpConnectionType** specifies the properties that are necessary to connect to an HTTP data source.

The following is the XSD of the **HttpConnectionType** type.

```
<xs:complexType name="HttpConnectionType">
  <xs:sequence>
    <xs:element name="Property"
      minOccurs="0" maxOccurs="unbounded">
      <xs:complexType>
        <xs:complexContent>
          <xs:extension base="DTS:PropertyElementBaseType">
            <xs:attribute name="Name"
              type="DTS:HttpConnectionPropertyNameEnum"
              use="required"/>
            <xs:attribute name="Sensitive" form="unqualified">
              <xs:simpleType>
                <xs:restriction base="xs:int">
                  <xs:minInclusive value="0"/>
                  <xs:maxInclusive value="1"/>
                </xs:restriction>
              </xs:simpleType>
            </xs:attribute>
            <xs:attribute name="Encrypted" form="unqualified">
              <xs:simpleType>
                <xs:restriction base="xs:int">
                  <xs:minInclusive value="0"/>
                  <xs:maxInclusive value="1"/>
                </xs:restriction>
              </xs:simpleType>
            </xs:attribute>
          </xs:extension>
        </xs:complexContent>
      </xs:complexType>
    </xs:element>
  </xs:sequence>
</xs:complexType>
```

The following table provides additional information about the attributes and types for the **Property** element that is declared inline in the complex type declaration. The **Property** element is an extension of the [PropertyElementBaseType](#) type with the addition of the attributes that are specified in the following table.

| Attribute | Constraints | Description |
|------------------|-------------|---|
| Name | None. | Specifies the name of the Property element. Each named property has its own use and interpretation. The explanation for the interpretation of each named property is given with the definition of the type for the Name attribute. |
| Sensitive | None. | The element value contains an indicator for whether the property information is treated as sensitive. The integer value has the following meanings: 0 = The property value is not considered to be sensitive. 1 = The property value is considered to be sensitive. Depending on the setting of the ProtectionLevel value in an ancestor level to the containing element, the value of the property can or cannot be displayed if the property is considered to be sensitive. |
| Encrypted | None | The attribute value contains an indicator for whether the element value is encrypted. FALSE – Specifies that the element value is not encrypted. TRUE – Specifies that the element value is encrypted. For more details about the encryption algorithm that is used if the value of the Encrypted attribute is TRUE, see section 4. |

2.4.4.2.1.5.1 HttpConnectionPropertyNameEnum

The **HttpConnectionPropertyNameEnum** type contains the values for the **Name** attribute of the **Property** elements that are allowed for the [HttpConnectionType](#) complex type.

The following is the XSD for the **HttpConnectionPropertyNameEnum** type.

```
<xs:simpleType name="HttpConnectionPropertyNameEnum">
  <xs:restriction base="xs:string">
    <xs:enumeration value="ServerURL"/>
    <xs:enumeration value="UseServerCredentials"/>
    <xs:enumeration value="ServerUserName"/>
    <xs:enumeration value="ServerPassword"/>
    <xs:enumeration value="ServerDomain"/>
    <xs:enumeration value="UseSecureConnection"/>
    <xs:enumeration value="CertificateIdentifier"/>
    <xs:enumeration value="Certificate"/>
    <xs:enumeration value="TimeOut"/>
    <xs:enumeration value="ChunkSize"/>
    <xs:enumeration value="UseProxy"/>
    <xs:enumeration value="ProxyURL"/>
    <xs:enumeration value="BypassProxyOnLocal"/>
    <xs:enumeration value="UseProxyCredentials"/>
    <xs:enumeration value="ProxyUserName"/>
    <xs:enumeration value="ProxyPassword"/>
    <xs:enumeration value="ProxyDomain"/>
    <xs:enumeration value="BypassList"/>
  </xs:restriction>
</xs:simpleType>
```

The following table specifies the enumeration values for the **HttpConnectionPropertyNameEnum** type.

| Enumeration value | Description |
|-------------------|---|
| ServerURL | Specifies a string value that contains the URL location of the HTTP server. |

| Enumeration value | Description |
|------------------------------|--|
| UseServerCredentials | Specifies that the element value contains an indicator for whether to use network credentials. For additional restrictions, see Property Name=UseServerCredentials . |
| ServerUserName | Specifies a string value that contains the user name to log on to the server. |
| ServerPassword | Specifies a string value that contains the password to use on the server. |
| ServerDomain | Specifies a string value that contains the domain name for the server. |
| UseSecureConnection | Specifies that the element value contains an indicator for whether to use an HTTP or an HTTPS connection. For additional restrictions, see Property Name=UseSecureConnection . |
| CertificateIdentifier | Specifies that the value contains the X.509 [RFC2459] certificate identifier. |
| Certificate | Specifies the client certificate to the HTTP server in base64. |
| TimeOut | Specifies an integer that contains the number of seconds after which the connection times out. |
| ChunkSize | Specifies an integer value that contains the minimum number of bytes to read or write from the server. |
| UseProxy | Specifies that the element value contains an indicator for whether to use a proxy server. For additional restrictions, see Property Name=UseProxy . |
| ProxyURL | Specifies a string value that contains the URL location of the proxy server. |
| BypassProxyOnLocal | Specifies that the element value contains an indicator for whether to bypass a proxy server and use a local address instead. For additional restrictions, see Property Name=ByPassProxyOnLocal . |
| UseProxyCredentials | Specifies that the element value contains an indicator for whether to use network credentials. For additional restrictions, see Property Name=UseProxyCredentials . |
| ProxyUserName | Specifies a string value that contains the name of the user to log on to the proxy server. |
| ProxyPassword | Specifies a string value that contains the password for the ProxyUserName account on the proxy server. |
| ProxyDomain | Specifies a string value that contains the domain name for the proxy server. |
| BypassList | Specifies a string value that contains a list of addresses that do not use the proxy server. |

2.4.4.2.1.5.1.1 Property Name=UseServerCredentials

When the **Property** element's **Name** attribute value is **UseServerCredentials**, the values that are allowed for the **Property** element are more restricted than the values that are specified by the XSD type declaration for the **Property** element of the [HttpConnectionType](#) type.

In this case, the allowed values for the **Property** element value MUST be one of the values in the following table.

| Element value | Description |
|---------------|---|
| 0 | False. Species that the connection does not use server credentials. |

| Element value | Description |
|---------------|--|
| -1 | True. Species that the connection uses server credentials. |

2.4.4.2.1.5.1.2 Property Name=UseSecureConnection

When the **Property** element's **Name** attribute value is **UseSecureConnection**, the values that are allowed for the **Property** element are more restricted than the values that are specified by the XSD type declaration for the **Property** element of the [HttpConnectionType](#) type.

In this case, the allowed values for the **Property** element value MUST be one of the values in the following table.

| Element value | Description |
|---------------|--|
| 0 | False. Specifies that the connection uses the HTTP protocol. |
| -1 | True. Specifies that the connection uses the HTTPS protocol. |

2.4.4.2.1.5.1.3 Property Name=UseProxy

When the **Property** element's **Name** attribute value is **UseProxy**, the values that are allowed for the **Property** element are more restricted than the values that are specified by the XSD type declaration for the **Property** element of the [HttpConnectionType](#) type. In this case, the allowed values for the **Property** element value MUST be one of the values in the following table.

| Element value | Description |
|---------------|---|
| 0 | False. Specifies that the connection does not use a proxy server. |
| -1 | True. Specifies that the connection uses a proxy server. |

2.4.4.2.1.5.1.4 Property Name=ByPassProxyOnLocal

When the **Property** element's **Name** attribute value is **ByPassProxyOnLocal**, the values that are allowed for the **Property** element are more restricted than the values that are specified by the XSD type declaration for the **Property** element of the [HttpConnectionType](#) type.

In this case, the allowed values for the **Property** element value MUST be one of the values in the following table.

| Element value | Description |
|---------------|--|
| 0 | False. Specifies that the connection does not bypass the proxy server for local addresses. |
| -1 | True. Specifies that the connection bypasses the proxy server for local addresses. |

2.4.4.2.1.5.1.5 Property Name=UseProxyCredentials

When the **Property** element's **Name** attribute value is **UseProxyCredentials**, the values that are allowed for the **Property** element are more restricted than the values that are specified by the XSD type declaration for the **Property** element of the [HttpConnectionType](#) type.

In this case, the allowed values for the **Property** element value MUST be one of the values in the following table.

| Element value | Description |
|---------------|--|
| 0 | False. Specifies that the connection does not use proxy credentials. |
| -1 | True. Specifies that the connection uses proxy credentials. |

2.4.4.2.2 ConnectionManagerObjectDataMsmqConnectionManagerType

The **ConnectionManagerObjectDataMsmqConnectionManagerType** is the type of the **MsmqConnectionManager** element that is a child of the **ObjectData** element when the type of the connection is to an MSMQ.

The following is the XSD of the **ConnectionManagerObjectDataMsmqConnectionManagerType** complex type.

```
<xs:complexType
  name="ConnectionManagerObjectDataMsmqConnectionManagerType">
  <xs:sequence/>
  <xs:attribute name="ConnectionString" type="xs:string"
    form="unqualified"/>
</xs:complexType>
```

The **ConnectionManagerObjectDataMsmqConnectionManagerType** type MUST NOT contain any elements.

The following table specifies the attributes for the **ConnectionManagerObjectDataMsmqConnectionManagerType** type.

| Attribute | Constraints | Description |
|-------------------------|-------------|--|
| ConnectionString | None. | The connection string to an MSMQ source. |

2.4.4.2.3 ConnectionManagerObjectDataSMOServerConnectionManagerType

The **ConnectionManagerObjectDataSMOServerConnectionManagerType** is the type of the **SMOServerConnectionManager** element that is a child of the **ObjectData** element when the type of the connection is to a database that is using the Server Management Objects (SMO) object model for server management. [<6>](#)

The following is the XSD of the **ConnectionManagerObjectDataSMOServerConnectionManagerType** complex type.

```
<xs:complexType
  name="ConnectionManagerObjectDataSMOServerConnectionManagerType">
  <xs:sequence>
    <xs:element name="PassWord" type=
      "DTS>PasswordElementType"
      form="unqualified"/>
  </xs:sequence>
</xs:complexType>
```

```

    </xs:sequence>
    <xs:attribute name="ConnectionString" type="xs:string"
        form="unqualified" use="required"/>
</xs:complexType>

```

The following tables specify the elements and attributes for the **ConnectionManagerObjectDataSMOServerConnectionManagerType** type.

| Element | Constraints | Description |
|-----------------|-------------|---|
| Password | None. | The password for the connection to the SMO server source. The password can be encrypted, depending on the settings of the attribute values for the password element. |

| Element | Constraints | Description |
|-------------------------|-------------|---|
| ConnectionString | None. | The connection string to an SMO server source. |

2.4.4.2.4 ConnectionManagerObjectDataSmtplibConnectionManagerType

The **ConnectionManagerObjectDataSmtplibConnectionManagerType** is the type of the **SmtplibConnectionManager** element, which is a child of the **ObjectData** element when the type of the connection is to an SMTP server.

The following is the XSD of the **ConnectionManagerObjectDataSmtplibConnectionManagerType** complex type.

```

<xs:complexType
    name="ConnectionManagerObjectDataSmtplibConnectionManagerType">
  <xs:sequence/>
  <xs:attribute name="ConnectionString" type="xs:string"
      form="unqualified"/>
</xs:complexType>

```

The **ConnectionManagerObjectDataSmtplibConnectionManagerType** type MUST NOT contain any elements.

The following table specifies the attributes for the **ConnectionManagerObjectDataSmtplibConnectionManagerType** type.

| Attribute | Constraints | Description |
|-------------------------|-------------|--|
| ConnectionString | None. | The connection string to an SMTP source. |

2.4.4.2.5 ConnectionManagerObjectDataWmiConnectionManagerType

The **ConnectionManagerObjectDataWmiConnectionManagerType** complex type is the type of the **WmiConnectionManager** element, which is a child of the **ObjectData** element when the type of the connection is to a Windows Management Instrumentation (WMI) data source.

The following is the XSD of the **ConnectionManagerObjectDataWmiConnectionManagerType** complex type.

```
<xs:complexType
  name="ConnectionManagerObjectDataWmiConnectionManagerType">
  <xs:sequence>
    <xs:element name="PassWord" type=
      "DTS>PasswordElementType"
      form="unqualified"/>
  </xs:sequence>
  <xs:attribute name="ConnectionString" type="xs:string"
    form="unqualified"/>
</xs:complexType>
```

The following tables specify the elements and attributes for the **ConnectionManagerObjectDataWmiConnectionManagerType** complex type.

| Attribute | Constraints | Description |
|-------------------------|-------------|---|
| ConnectionString | None. | Specifies that the connection string is to a WMI data source. |

2.4.4.3 ConnectionManagerObjectDataType Information for Data Sources

The type of data source for which the connection manager specifies access carries with it important constraints that are not fully expressed in the XSD code fragments. These additional constraints, which are explained in the subsections of this section, **MUST** be followed for each specific data source type. The important differences that vary by the data source type are the following:

- Allowed values for the **Name** attribute of the **Property** element within the **ObjectData** element can differ between different data sources. The same limitations apply to the **PropertyExpression** element within a **ConnectionManager** instance.
- The choice that is contained within the complex type definition for [ConnectionManagerObjectDataType](#) is also constrained by the type of data source. Not all of the choices in the XSD are available for each data source type.
- For those data sources that allow a **ConnectionManager** element to be contained by the **ObjectData** element, the choice that is contained within the complex type definition for the **ConnectionManager** element of the **ConnectionManagerObjectDataType** is also constrained by the type of data source. Not all of the choices in the XSD are available for each data source type.

2.4.4.3.1 OLE DB Data Source

When the connection manager is to an OLE DB data source, the formal type of the **ObjectData** element is the [ConnectionManagerObjectDataType](#) type. However, the following XSD fragment, which is expressed as an anonymous complex type declaration, places further restrictions on the type from the restrictions that are declared in the formal type declaration. A **ConnectionManager** instance to an OLE DB source **MUST** follow the restrictions that are shown in this anonymous XSD fragment.

Note the following differences between this anonymous complex type declaration and the full definition of the complex type for the **ConnectionManagerObjectDataType** type:

- The value for the **CreationName Property** of the containing **ConnectionManager** element **MUST** be "OLEDB".

- The **ObjectData** element type MUST be of the type that is specified by the anonymous XSD definition that is contained in this section.
- The **ObjectData** element MUST contain a **ConnectionManager** element.
- The **ConnectionManager** child element to the **ObjectData** element MUST NOT include properties, except for those that are specified as valid in this anonymous XSD fragment, which is a restriction of the properties that are contained in the [ConnectionManagerObjectDataPropertyNameEnum](#) type. The **PropertyExpression** element of the containing **ConnectionManager** element also MUST NOT include properties, except for those that are specified as valid for the **Property** element children of the **ConnectionManager** element in this anonymous XSD fragment.

This anonymous type declaration acts as a replacement for the definition for **ConnectionManagerObjectDataType** type in the case of an OLE DB data source.

```
<xs:complexType>
  <xs:choice>
    <xs:element name="ConnectionManager">
      <xs:complexType>
        <xs:sequence>
          <xs:element name="Property"
            minOccurs="0" maxOccurs="unbounded">
            <xs:complexType>
              <xs:complexContent>
                <xs:extension base="DTS:PropertyElementBaseType">
                  <xs:attribute name="Name"
                    use="required">
                    <xs:simpleType>
                      <xs:restriction
                        base="DTS:ConnectionManagerObjectDataPropertyNameEnum">
                        <xs:enumeration value="Retain"/>
                        <xs:enumeration value="ConnectionString"/>
                      </xs:restriction>
                    </xs:simpleType>
                  </xs:attribute>
                </xs:extension>
              </xs:complexContent>
            </xs:complexType>
          </xs:element>
        </xs:sequence>
      </xs:complexType>
    </xs:element>
  </xs:choice>
</xs:complexType>
```

2.4.4.3.2 Flat File Data Source

When the connection manager is to a flat file data source, the formal type of the **ObjectData** element is the [ConnectionManagerObjectDataType](#) type. However, the following XSD fragment, which is expressed as an anonymous complex type declaration, places further restrictions on the type than the restrictions that are declared in the formal type declaration. A **ConnectionManager** instance to a flat file source MUST follow the restrictions that are shown in this anonymous XSD fragment.

Note the following differences between this anonymous complex type declaration and the full definition of the complex type for the **ConnectionManagerObjectDataType** type:

- The value for the **CreationName Property** of the containing **ConnectionManager** element MUST be "FLATFILE".
- The **ObjectData** element type MUST be of the type that is specified by the anonymous XSD definition that is contained in this section.

- The **ObjectData** element MUST contain a **ConnectionManager** element.
- The **ConnectionManager** child element to the **ObjectData** element MUST NOT include properties, except for those that are specified as valid in this anonymous XSD fragment, which is a restriction of the properties that are contained in the [ConnectionManagerObjectDataPropertyNameEnum](#) type. The **PropertyExpression** element of the containing **ConnectionManager** element also MUST NOT include properties, except for those that are specified as valid for the **Property** element children of the **ConnectionManager** element in this anonymous XSD fragment.

This anonymous type declaration acts as a replacement for the definition for **ConnectionManagerObjectDataType** type in the case of a flat file data source.

```
<xs:complexType>
  <xs:choice>
    <xs:element name="ConnectionManager">
      <xs:complexType>
        <xs:sequence>
          <xs:element name="Property"
            minOccurs="0" maxOccurs="unbounded">
            <xs:complexType>
              <xs:complexContent>
                <xs:extension base="DTS:PropertyElementBaseType">
                  <xs:attribute name="Name"
                    use="required">
                    <xs:simpleType>
                      <xs:restriction
                        base="DTS:ConnectionManagerObjectDataPropertyNameEnum">
                          <xs:enumeration value="ConnectionString"/>
                          <xs:enumeration value="FileUsageType"/>
                          <xs:enumeration value="Format"/>
                          <xs:enumeration value="LocaleID"/>
                          <xs:enumeration value="Unicode"/>
                          <xs:enumeration value="HeaderRowsToSkip"/>
                          <xs:enumeration value="HeaderRowDelimiter"/>
                          <xs:enumeration value="ColumnNamesInFirstDataRow"/>
                          <xs:enumeration value="RowDelimiter"/>
                          <xs:enumeration value="DataRowsToSkip"/>
                          <xs:enumeration value="TextQualifier"/>
                          <xs:enumeration value="CodePage"/>
                        </xs:restriction>
                      </xs:simpleType>
                    </xs:attribute>
                  </xs:extension>
                </xs:complexContent>
              </xs:complexType>
            </xs:element>
          </xs:sequence>
        </xs:complexType>
      </xs:element>
    </xs:choice>
  </xs:complexType>
```

2.4.4.3.3 ADO.NET Data Source

When the connection manager is to an ADO.NET data source, the formal type of the **ObjectData** element is the [ConnectionManagerObjectDataType](#) type. However, the following XSD fragment, which is expressed as an anonymous complex type declaration, places further restrictions on the type from the restrictions that are declared in the formal type declaration. A **ConnectionManager** instance to an ADO.NET source MUST follow the restrictions that are shown in this anonymous XSD fragment.

Note the following differences between this anonymous complex type declaration and the full definition of the complex type for the **ConnectionManagerObjectDataType** type:

- The value for the **CreationName Property** of the containing **ConnectionManager** element MUST be the string "ADO.NET:" concatenated together with the fully qualified name of a valid ADO.NET assembly. The **ObjectData** element type MUST be of the type that is specified by the anonymous XSD definition that is contained in this section.
- The **ObjectData** element MUST contain a **ConnectionManager** element.
- The **ConnectionManager** child element to the **ObjectData** element MUST NOT include properties, except for those that are specified as valid in this anonymous XSD fragment, which is a restriction of the properties that are contained in the [ConnectionManagerObjectDataPropertyNameEnum](#) type. The **PropertyExpression** element of the containing **ConnectionManager** element also MUST NOT include properties, except for those that are specified as valid for the **Property** element children of the **ConnectionManager** element in this anonymous XSD fragment.

This anonymous type declaration acts as a replacement for the definition for **ConnectionManagerObjectDataType** type in the case of an ADO.NET data source.

```
<xs:complexType>
  <xs:choice>
    <xs:element name="ConnectionManager">
      <xs:complexType>
        <xs:sequence>
          <xs:element name="Property"
            minOccurs="0" maxOccurs="unbounded">
            <xs:complexType>
              <xs:complexContent>
                <xs:extension base="DTS:PropertyElementBaseType">
                  <xs:attribute name="Name"
                    use="required">
                    <xs:simpleType>
                      <xs:restriction
                        base="DTS:ConnectionManagerObjectDataPropertyNameEnum">
                        <xs:enumeration value="Retain"/>
                        <xs:enumeration value="ConnectionString"/>
                        <xs:enumeration value="ServerName"/>
                      </xs:restriction>
                    </xs:simpleType>
                  </xs:attribute>
                </xs:extension>
              </xs:complexContent>
            </xs:complexType>
          </xs:element>
        </xs:sequence>
      </xs:complexType>
    </xs:element>
  </xs:choice>
</xs:complexType>
```

2.4.4.3.4 Analysis Services Data Source

When the connection manager is to an Analysis Services data source, the formal type of the **ObjectData** element is the [ConnectionManagerObjectDataType](#) type. However, the following XSD fragment, which is expressed as an anonymous complex type declaration, places further restrictions on the type than the restrictions that are declared in the formal type declaration. A **ConnectionManager** instance to an Analysis Services source MUST follow the restrictions that are shown in this anonymous XSD fragment.

Note the following differences between this anonymous complex type declaration and the full definition of the complex type for the **ConnectionManagerObjectDataType** type:

- The value for the **CreationName Property** of the containing **ConnectionManager** element MUST be "MSOLAP100".

- The **ObjectData** element type MUST be of the type that is specified by the anonymous XSD definition that is contained in this section.
- The **ObjectData** element MUST contain a **ConnectionManager** element.
- The **ConnectionManager** child element to the **ObjectData** element MUST NOT include properties, except for those that are specified as valid in this anonymous XSD fragment, which is a restriction of the properties that are contained in the [ConnectionManagerObjectDataPropertyNameEnum](#) type. The **PropertyExpression** element of the containing **ConnectionManager** element also MUST NOT include properties, except for those that are specified as valid for the **Property** element children of the **ConnectionManager** element in this anonymous XSD fragment.

This anonymous type declaration acts as a replacement for the definition for **ConnectionManagerObjectDataType** type in the case of an Analysis Services data source.

```
<xs:complexType>
  <xs:choice>
    <xs:element name="ConnectionManager">
      <xs:complexType>
        <xs:sequence>
          <xs:element name="Property"
            minOccurs="0" maxOccurs="unbounded">
            <xs:complexType>
              <xs:complexContent>
                <xs:extension base="DTS:PropertyElementBaseType">
                  <xs:attribute name="Name"
                    use="required">
                    <xs:simpleType>
                      <xs:restriction
                        base="DTS:ConnectionManagerObjectDataPropertyNameEnum">
                        <xs:enumeration value="Retain"/>
                        <xs:enumeration value="ConnectionString"/>
                      </xs:restriction>
                    </xs:simpleType>
                  </xs:attribute>
                </xs:extension>
              </xs:complexContent>
            </xs:complexType>
          </xs:element>
        </xs:sequence>
      </xs:complexType>
    </xs:element>
  </xs:choice>
</xs:complexType>
```

2.4.4.3.5 File Data Source

When the connection manager is to a File data source, the formal type of the **ObjectData** element is the [ConnectionManagerObjectDataType](#) type. However, the following XSD fragment, which is expressed as an anonymous complex type declaration, places further restrictions on the type than the restrictions that are declared in the formal type declaration. A **ConnectionManager** instance to a File data source MUST follow the restrictions that are shown in this anonymous XSD fragment.

Note the following differences between this anonymous complex type declaration and the full definition of the complex type for the **ConnectionManagerObjectDataType** type:

- The value for the **CreationName Property** of the containing **ConnectionManager** element MUST be "FILE".
- The **ObjectData** element type MUST be of the type that is specified by the anonymous XSD definition that is contained in this section.

- The **ObjectData** element MUST contain a **ConnectionManager** element.
- The **ConnectionManager** child element to the **ObjectData** element MUST NOT include properties, except for those that are specified as valid in this anonymous XSD fragment, which is a restriction of the properties that are contained in the [ConnectionManagerObjectDataPropertyNameEnum](#) type. The **PropertyExpression** element of the containing **ConnectionManager** element also MUST NOT include properties, except for those that are specified as valid for the **Property** element children of the **ConnectionManager** element in this anonymous XSD fragment.

This anonymous type declaration acts as a replacement for the definition for **ConnectionManagerObjectDataType** type in the case of a File data source.

```
<xs:complexType>
  <xs:choice>
    <xs:element name="ConnectionManager">
      <xs:complexType>
        <xs:sequence>
          <xs:element name="Property"-
            minOccurs="0" maxOccurs="unbounded">
            <xs:complexType>
              <xs:complexContent>
                <xs:extension base="DTS:PropertyElementBaseType">
                  <xs:attribute name="Name"
                    use="required">
                    <xs:simpleType>
                      <xs:restriction
                        base="DTS:ConnectionManagerObjectDataPropertyNameEnum">
                        <xs:enumeration value="ConnectionString"/>
                        <xs:enumeration value="FileUsageType"/>
                      </xs:restriction>
                    </xs:simpleType>
                  </xs:attribute>
                </xs:extension>
              </xs:complexContent>
            </xs:complexType>
          </xs:element>
        </xs:sequence>
      </xs:complexType>
    </xs:choice>
  </xs:complexType>
```

2.4.4.3.6 Cache Data Source

When the connection manager is to a Cache data source, the formal type of the **ObjectData** element is the [ConnectionManagerObjectDataType](#) type. However, the following XSD fragment, which is expressed as an anonymous complex type declaration, places further restrictions on the type than the restrictions that are declared in the formal type declaration. A **ConnectionManager** instance to a Cache data source MUST follow the restrictions that are shown in this anonymous XSD fragment.

Note the following differences between this anonymous complex type declaration and the full definition of the complex type for the **ConnectionManagerObjectDataType** type:

- The value for the **CreationName Property** of the containing **ConnectionManager** element MUST be "CACHE".
- The **ObjectData** element type MUST be of the type that is specified by the anonymous XSD definition that is contained in this section.
- The **ObjectData** element MUST contain a **ConnectionManager** element.

- The **ConnectionManager** child element to the **ObjectData** element MUST NOT include properties, except for those that are specified as valid in this anonymous XSD fragment, which is a restriction of the properties that are contained in the [ConnectionManagerObjectDataPropertyNameEnum](#) type. The **PropertyExpression** element of the containing **ConnectionManager** element also MUST NOT include properties, except for those that are specified as valid for the **Property** element children of the **ConnectionManager** element in this anonymous XSD fragment.

This anonymous type declaration acts as a replacement for the definition for **ConnectionManagerObjectDataType** type in the case of a Cache data source.

```
<xs:complexType>
  <xs:choice>
    <xs:element name="ConnectionManager">
      <xs:complexType>
        <xs:sequence>
          <xs:element name="Property"
            minOccurs="0" maxOccurs="unbounded">
            <xs:complexType>
              <xs:complexContent>
                <xs:extension base="DTS:PropertyElementBaseType">
                  <xs:attribute name="Name"
                    use="required">
                    <xs:simpleType>
                      <xs:restriction
                        base="DTS:ConnectionManagerObjectDataPropertyNameEnum">
                        <xs:enumeration value="UseFile"/>
                        <xs:enumeration value="UseEncryption"/>
                        <xs:enumeration value="RetainData"/>
                      </xs:restriction>
                    </xs:simpleType>
                  </xs:attribute>
                </xs:extension>
              </xs:complexContent>
            </xs:complexType>
          </xs:element>
        </xs:sequence>
      </xs:complexType>
    </xs:element>
  </xs:choice>
</xs:complexType>
```

2.4.4.3.7 Excel Data Source

When the connection manager is to an Excel data source, the formal type of the **ObjectData** element is the [ConnectionManagerObjectDataType](#) type. However, the following XSD fragment, which is expressed as an anonymous complex type declaration, places further restrictions on the type from the restrictions that are declared in the formal type declaration. A **ConnectionManager** instance to an Excel source MUST follow the restrictions that are shown in this anonymous XSD fragment.

Note the following differences between this anonymous complex type declaration and the full definition of the complex type for the **ConnectionManagerObjectDataType** type:

- The value for the **CreationName Property** of the containing **ConnectionManager** element MUST be "EXCEL".
- The **ObjectData** element type MUST be of the type that is specified by the anonymous XSD definition that is contained in this section.
- The **ObjectData** element MUST contain a **ConnectionManager** element.
- The **ConnectionManager** child element to the **ObjectData** element MUST NOT include properties, except for those that are specified as valid in this anonymous XSD fragment, which is a

restriction of the properties that are contained in the [ConnectionManagerObjectDataPropertyNameEnum](#) type. The **PropertyExpression** element of the containing **ConnectionManager** element also MUST NOT include properties, except for those that are specified as valid for the **Property** element children of the **ConnectionManager** element in this anonymous XSD fragment.

This anonymous type declaration acts as a replacement for the definition for **ConnectionManagerObjectDataType** type in the case of an Excel data source.

```
<xs:complexType>
  <xs:choice>
    <xs:element name="ConnectionManager">
      <xs:complexType>
        <xs:sequence>
          <xs:element name="Property"
            minOccurs="0" maxOccurs="unbounded">
            <xs:complexType>
              <xs:complexContent>
                <xs:extension base="DTS:PropertyElementBaseType">
                  <xs:attribute name="Name"
                    use="required">
                    <xs:simpleType>
                      <xs:restriction
                        base="DTS:ConnectionManagerObjectDataPropertyNameEnum">
                        <xs:enumeration value="Retain"/>
                        <xs:enumeration value="ConnectionString"/>
                      </xs:restriction>
                    </xs:simpleType>
                  </xs:attribute>
                </xs:extension>
              </xs:complexContent>
            </xs:complexType>
          </xs:element>
        </xs:sequence>
      </xs:complexType>
    </xs:element>
  </xs:choice>
</xs:complexType>
```

2.4.4.3.8 FTP Data Source

When the connection manager is to an FTP data source, the formal type of the **ObjectData** element is the [ConnectionManagerObjectDataType](#) type. However, the following XSD fragment, which is expressed as an anonymous complex type declaration, places further restrictions on the type from the restrictions that are declared in the formal type declaration. A connection manager instance to an FTP source MUST follow the restrictions that are shown in this anonymous XSD fragment.

Note the following differences between this anonymous complex type declaration and the full definition of the complex type for the **ConnectionManagerObjectDataType** type:

- The value for the **CreationName Property** of the containing **ConnectionManager** element MUST be "FTP".
- The **ObjectData** element type MUST be of the type that is specified by the anonymous XSD definition that is contained in this section.
- The **ObjectData** element MUST contain a **ConnectionManager** element.
- The **ConnectionManager** child element to the **ObjectData** element MUST NOT include properties, except for those that are specified as valid in this anonymous XSD fragment, which is a restriction of the properties that are contained in the [ConnectionManagerObjectDataPropertyNameEnum](#) type. The **PropertyExpression** element of the containing **ConnectionManager** element also MUST NOT include properties, except for those that

are specified as valid for the **Property** element children of the **ConnectionManager** element in this anonymous XSD fragment.

This anonymous type declaration acts as a replacement for the definition for **ConnectionManagerObjectDataType** type in the case of an FTP data source.

```
<xs:complexType>
  <xs:choice>
    <xs:element name="ConnectionManager">
      <xs:complexType>
        <xs:sequence>
          <xs:element name="Property"
            minOccurs="0" maxOccurs="unbounded">
            <xs:complexType>
              <xs:complexContent>
                <xs:extension base="DTS:PropertyElementBaseType">
                  <xs:attribute name="Name"
                    use="required">
                    <xs:simpleType>
                      <xs:restriction
                        base="DTS:ConnectionManagerObjectDataPropertyNameEnum">
                        <xs:enumeration value="ConnectionString"/>
                      </xs:restriction>
                    </xs:simpleType>
                  </xs:attribute>
                </xs:extension>
              </xs:complexContent>
            </xs:complexType>
          </xs:element>
        </xs:sequence>
      </xs:complexType>
    </xs:element>
  </xs:choice>
</xs:complexType>
```

2.4.4.3.9 HTTP Data Source

When the connection manager is to an HTTP data source, the formal type of the **ObjectData** element is the [ConnectionManagerObjectDataType](#) type. However, the following XSD fragment, which is expressed as an anonymous complex type declaration, places further restrictions on the type than the restrictions that are declared in the formal type declaration. A **ConnectionManager** instance to an HTTP source MUST follow the restrictions that are shown in this anonymous XSD fragment.

Note the following differences between this anonymous complex type declaration and the full definition of the complex type for the **ConnectionManagerObjectDataType** type:

- The value for the **CreationName Property** of the containing **ConnectionManager** element MUST be "HTTP".
- The **ObjectData** element type MUST be of the type that is specified by the anonymous XSD definition that is contained in this section.
- The **ObjectData** element MUST contain a **ConnectionManager** element.
- The **ConnectionManager** child element to the **ObjectData** element MUST NOT include properties, except for those that are specified as valid in this anonymous XSD fragment, which is a restriction of the properties that are contained in the [ConnectionManagerObjectDataPropertyNameEnum](#) type. The **PropertyExpression** element of the containing **ConnectionManager** element also MUST NOT include properties, except for those that are specified as valid for the **Property** element children of the **ConnectionManager** element in this anonymous XSD fragment.

This anonymous type declaration acts as a replacement for the definition for **ConnectionManagerObjectDataType** type in the case of an HTTP data source.

```
<xs:complexType>
  <xs:choice>
    <xs:element name="ConnectionManager">
      <xs:complexType>
        <xs:sequence>
          <xs:element name="Property"
            minOccurs="0" maxOccurs="unbounded">
            <xs:complexType>
              <xs:complexContent>
                <xs:extension base="DTS:PropertyElementBaseType">
                  <xs:attribute name="Name"
                    use="required">
                    <xs:simpleType>
                      <xs:restriction
                        base="DTS:ConnectionManagerObjectDataPropertyNameEnum">
                        <xs:enumeration value="ConnectionString"/>
                        </xs:restriction>
                      </xs:simpleType>
                    </xs:attribute>
                  </xs:extension>
                </xs:complexContent>
              </xs:complexType>
            </xs:element>
          </xs:sequence>
        </xs:complexType>
      </xs:element>
    </xs:choice>
  </xs:complexType>
```

2.4.4.3.10 MSMQ Data Source

When the connection manager is to an MSMQ data source, the formal type of the **ObjectData** element is the [ConnectionManagerObjectDataType](#) type. However, the following XSD fragment, which is expressed as an anonymous complex type declaration, places further restrictions on the type than the restrictions that are declared in the formal type declaration. A **ConnectionManager** instance to an MSMQ source MUST follow the restrictions that are shown in this anonymous XSD fragment.

Note the following differences between this anonymous complex type declaration and the full definition of the complex type for the **ConnectionManagerObjectDataType** type:

- The value for the **CreationNameProperty** of the containing **ConnectionManager** element MUST be "MSMQ".
- The **ObjectData** element type MUST be of the type that is specified by the anonymous XSD definition that is contained in this section.
- The **ObjectData** element MUST contain an **MsmqConnectionManager** element of type [ConnectionManagerObjectDataMsmqConnectionManagerType](#).

This anonymous type declaration acts as a replacement for the definition for **ConnectionManagerObjectDataType** type in the case of an MSMQ source.

```
<xs:complexType>
  <xs:choice>
    <xs:element name="MsmqConnectionManager"
      type="DTS:ConnectionManagerObjectDataMsmqConnectionManagerType"/>
  </xs:choice>
</xs:complexType>
```

2.4.4.3.11 MULTIFILE Data Source

When the connection manager is to a multiple file data source, the formal type of the **ObjectData** element is the [ConnectionManagerObjectDataType](#) type. However, the following XSD fragment, which is expressed as an anonymous complex type declaration, places further restrictions on the type than the restrictions that are declared in the formal type declaration. A **ConnectionManager** instance to a multiple file data source MUST follow the restrictions that are shown in this anonymous XSD fragment.

Note the following differences between this anonymous complex type declaration and the full definition of the complex type for the **ConnectionManagerObjectDataType** type:

- The value for the **CreationName Property** of the containing **ConnectionManager** element MUST be "MULTIFILE".
- The **ObjectData** element type MUST be of the type that is specified by the anonymous XSD definition that is contained in this section.
- The **ObjectData** element MUST contain a **ConnectionManager** element.
- The **ConnectionManager** child element to the **ObjectData** element MUST NOT include properties, except for those that are specified as valid in this anonymous XSD fragment, which is a restriction of the properties that are contained in the [ConnectionManagerObjectDataPropertyNameEnum](#) type. The **PropertyExpression** element of the containing **ConnectionManager** element also MUST NOT include properties, except for those that are specified as valid for the **Property** element children of the **ConnectionManager** element in this anonymous XSD fragment.

This anonymous type declaration acts as a replacement for the definition for **ConnectionManagerObjectDataType** type in the case of a multiple file data source.

```
<xs:complexType>
  <xs:choice>
    <xs:element name="ConnectionManager">
      <xs:complexType>
        <xs:sequence>
          <xs:element name="Property"
            minOccurs="0" maxOccurs="unbounded">
            <xs:complexType>
              <xs:complexContent>
                <xs:extension base="DTS:PropertyElementBaseType">
                  <xs:attribute name="Name"
                    use="required">
                    <xs:simpleType>
                      <xs:restriction
                        base="DTS:ConnectionManagerObjectDataPropertyNameEnum">
                        <xs:enumeration value="ConnectionString"/>
                        <xs:enumeration value="FileUsageType"/>
                      </xs:restriction>
                    </xs:simpleType>
                  </xs:attribute>
                </xs:extension>
              </xs:complexContent>
            </xs:complexType>
          </xs:element>
        </xs:sequence>
      </xs:complexType>
    </xs:element>
  </xs:choice>
</xs:complexType>
```

2.4.4.3.12 MULTIFLATFILE Data Source

When the connection manager is to a multiple flat file data source, the formal type of the **ObjectData** element is the [ConnectionManagerObjectDataType](#) type. However, the following XSD fragment, which is expressed as an anonymous complex type declaration, places further restrictions on the type than the restrictions that are declared in the formal type declaration. A **ConnectionManager** instance to a multiple flat file source MUST follow the restrictions that are shown in this anonymous XSD fragment.

Note the following differences between this anonymous complex type declaration and the full definition of the complex type for the **ConnectionManagerObjectDataType** type:

- The value for the **CreationName Property** of the containing **ConnectionManager** element MUST be "MULTIFLATFILE".
- The **ObjectData** element type MUST be of the type that is specified by the anonymous XSD definition that is contained in this section.
- The **ObjectData** element MUST contain a **ConnectionManager** element.
- The **ConnectionManager** child element to the **ObjectData** element MUST NOT include properties, except for those that are specified as valid in this anonymous XSD fragment, which is a restriction of the properties that are contained in the [ConnectionManagerObjectDataPropertyNameEnum](#) type. The **PropertyExpression** element of the containing **ConnectionManager** element also MUST NOT include properties, except for those that are specified as valid for the **Property** element children of the **ConnectionManager** element in this anonymous XSD fragment.

This anonymous type declaration acts as a replacement for the definition for **ConnectionManagerObjectDataType** type in the case of a multiple flat file data source.

```
<xs:complexType>
  <xs:choice>
    <xs:element name="ConnectionManager">
      <xs:complexType>
        <xs:sequence>
          <xs:element name="Property"
            minOccurs="0" maxOccurs="unbounded">
            <xs:complexType>
              <xs:complexContent>
                <xs:extension base="DTS:PropertyElementBaseType">
                  <xs:attribute name="Name"
                    use="required">
                    <xs:simpleType>
                      <xs:restriction
                        base="DTS:ConnectionManagerObjectDataPropertyNameEnum">
                        <xs:enumeration value="ConnectionString"/>
                        <xs:enumeration value="FileUsageType"/>
                        <xs:enumeration value="Format"/>
                        <xs:enumeration value="LocaleID"/>
                        <xs:enumeration value="Unicode"/>
                        <xs:enumeration value="HeaderRowsToSkip"/>
                        <xs:enumeration value="HeaderRowDelimiter"/>
                        <xs:enumeration value="ColumnNamesInFirstDataRow"/>
                        <xs:enumeration value="RowDelimiter"/>
                        <xs:enumeration value="DataRowsToSkip"/>
                        <xs:enumeration value="TextQualifier"/>
                        <xs:enumeration value="CodePage"/>
                      </xs:restriction>
                    </xs:simpleType>
                  </xs:attribute>
                </xs:extension>
              </xs:complexContent>
            </xs:complexType>
          </xs:element>
        </xs:sequence>
      </xs:complexType>
    </xs:element>
  </xs:choice>
</xs:complexType>
```

```

    </xs:choice>
  </xs:complexType>

```

2.4.4.3.13 ODBC Data Source

When the connection manager is to an ODBC data source, the formal type of the **ObjectData** element is the [ConnectionManagerObjectDataType](#) type. However, the following XSD fragment, which is expressed as an anonymous complex type declaration, places further restrictions on the type than the restrictions that are declared in the formal type declaration. A **ConnectionManager** instance to an ODBC source MUST follow the restrictions that are shown in this anonymous XSD fragment.

Note the following differences between this anonymous complex type declaration and the full definition of the complex type for the **ConnectionManagerObjectDataType** type:

- The value for the **CreationName Property** of the containing **ConnectionManager** element MUST be "ODBC".
- The **ObjectData** element type MUST be of the type that is specified by the anonymous XSD definition that is contained in this section.
- The **ObjectData** element MUST contain a **ConnectionManager** element.
- The **ConnectionManager** child element to the **ObjectData** element MUST NOT include properties, except for those that are specified as valid in this anonymous XSD fragment, which is a restriction of the properties that are contained in the [ConnectionManagerObjectDataPropertyNameEnum](#) type. The **PropertyExpression** element of the containing **ConnectionManager** element also MUST NOT include properties, except for those that are specified as valid for the **Property** element children of the **ConnectionManager** element in this anonymous XSD fragment.

This anonymous type declaration acts as a replacement for the definition for **ConnectionManagerObjectDataType** type in the case of an ODBC data source.

```

<xs:complexType>
  <xs:choice>
    <xs:element name="ConnectionManager">
      <xs:complexType>
        <xs:sequence>
          <xs:element name="Property"
            minOccurs="0" maxOccurs="unbounded">
            <xs:complexType>
              <xs:complexContent>
                <xs:extension base="DTS:PropertyElementBaseType">
                  <xs:attribute name="Name"
                    use="required">
                    <xs:simpleType>
                      <xs:restriction
                        base="DTS:ConnectionManagerObjectDataPropertyNameEnum">
                        <xs:enumeration value="Retain"/>
                        <xs:enumeration value="ConnectionString"/>
                        <xs:enumeration value="ServerName"/>
                      </xs:restriction>
                    </xs:simpleType>
                  </xs:attribute>
                </xs:extension>
              </xs:complexContent>
            </xs:complexType>
          </xs:element>
        </xs:sequence>
      </xs:complexType>
    </xs:element>
  </xs:choice>

```

```
</xs:complexType>
```

2.4.4.3.14 SMOServer Data Source

When the connection manager is to an SMOServer data source, the formal type of the **ObjectData** element is the [ConnectionManagerObjectDataType](#) type. However, the following XSD fragment, which is expressed as an anonymous complex type declaration, places further restrictions on the type than the restrictions that are declared in the formal type declaration. A **ConnectionManager** instance to an SMOServer source MUST follow the restrictions that are shown in this anonymous XSD fragment.

Note the following differences between this anonymous complex type declaration and the full definition of the complex type for the **ConnectionManagerObjectDataType** type:

- The value for the **CreationName Property** of the containing **ConnectionManager** element MUST be "SMOServer".
- The **ObjectData** element type MUST be of the type that is specified by the anonymous XSD definition that is contained in this section.
- The **ObjectData** element MUST contain an **SMOServerConnectionManager** element of type [ConnectionManagerObjectDataSMOServerConnectionManagerType](#).

This anonymous type declaration acts as a replacement for the definition for **ConnectionManagerObjectDataType** type in the case of an SMOServer data source.

```
<xs:complexType>
  <xs:choice>
    <xs:element name="SMOServerConnectionManager"
      type="DTS:ConnectionManagerObjectDataSMOServerConnectionManagerType"/>
  </xs:choice>
</xs:complexType>
```

2.4.4.3.15 SMTP Data Source

When the connection manager is to an SMTP source, the formal type of the **ObjectData** element is the [ConnectionManagerObjectDataType](#) type. However, the following XSD fragment, which is expressed as an anonymous complex type declaration, places further restrictions on the type than the restrictions that are declared in the formal type declaration. A **ConnectionManager** instance to an SMTP source MUST follow the restrictions that are shown in this anonymous XSD fragment.

Note the following differences between this anonymous complex type declaration and the full definition of the complex type for the **ConnectionManagerObjectDataType** type:

- The value for the **CreationName Property** of the containing **ConnectionManager** element MUST be "SMOServer".
- The **ObjectData** element type MUST be of the type that is specified by the anonymous XSD definition that is contained in this section.
- The **ObjectData** element MUST contain an **SmtplibConnectionManager** element of type [ConnectionManagerObjectDataSmtplibConnectionManagerType](#).

This anonymous type declaration acts as a replacement for the definition for **ConnectionManagerObjectDataType** type in the case of an SMTP data source.

```
<xs:complexType>
  <xs:choice>
    <xs:element name="SmtplibConnectionManager"
      type="DTS:ConnectionManagerObjectDataSmtplibConnectionManagerType"/>
  </xs:choice>
</xs:complexType>
```

```

        type="DTS:ConnectionManagerObjectDataSmtplibConnectionManagerType"/>
    </xs:choice>
</xs:complexType>

```

2.4.4.3.16 SQLMOBILE Data Source

When the connection manager is to a SQL Server Mobile data source, the formal type of the **ObjectData** element is the [ConnectionManagerObjectDataType](#) type. However, the following XSD fragment, which is expressed as an anonymous complex type declaration, places further restrictions on the type than the restrictions that are declared in the formal type declaration. A **ConnectionManager** instance to a SQL Server Mobile source **MUST** follow the restrictions that are shown in this anonymous XSD fragment.

Note the following differences between this anonymous complex type declaration and the full definition of the complex type for the **ConnectionManagerObjectDataType** type:

- The value for the **CreationName Property** of the containing **ConnectionManager** element **MUST** be "SQLMOBILE".
- The **ObjectData** element type **MUST** be of the type that is specified by the anonymous XSD definition that is contained in this section.
- The **ObjectData** element **MUST** contain a **ConnectionManager** element.
- The **ConnectionManager** child element to the **ObjectData** element **MUST NOT** include properties, except for those that are specified as valid in this anonymous XSD fragment, which is a restriction of the properties that are contained in the [ConnectionManagerObjectDataPropertyNameEnum](#) type. The **PropertyExpression** element of the containing **ConnectionManager** element also **MUST NOT** include properties, except for those that are specified as valid for the **Property** element children of the **ConnectionManager** element in this anonymous XSD fragment.

This anonymous type declaration acts as a replacement for the definition for **ConnectionManagerObjectDataType** type in the case of an SQL Server Mobile data source.

```

<xs:complexType>
  <xs:choice>
    <xs:element name="ConnectionManager">
      <xs:complexType>
        <xs:sequence>
          <xs:element name="Property"
            minOccurs="0" maxOccurs="unbounded">
            <xs:complexType>
              <xs:complexContent>
                <xs:extension base="DTS:PropertyElementBaseType">
                  <xs:attribute name="Name"
                    use="required">
                    <xs:simpleType>
                      <xs:restriction
                        base="DTS:ConnectionManagerObjectDataPropertyNameEnum">
                        <xs:enumeration value="ConnectionString"/>
                      </xs:restriction>
                    </xs:simpleType>
                  </xs:attribute>
                </xs:extension>
              </xs:complexContent>
            </xs:complexType>
          </xs:element>
        </xs:sequence>
      </xs:complexType>
    </xs:element>
  </xs:choice>
</xs:complexType>

```

```
</xs:complexType>
```

2.4.4.3.17 WMI Data Source

When the connection manager is to a WMI data source, the formal type of the **ObjectData** element is the [ConnectionManagerObjectDataType](#) type. However, the following XSD fragment, which is expressed as an anonymous complex type declaration, places further restrictions on the type than the restrictions that are declared in the formal type declaration. A **ConnectionManager** instance to a WMI source **MUST** follow the restrictions that are shown in this anonymous XSD fragment.

Note the following differences between this anonymous complex type declaration and the full definition of the complex type for the **ConnectionManagerObjectDataType** type:

- The value for the **CreationName Property** of the containing **ConnectionManager** element **MUST** be "WMI".
- The **ObjectData** element type **MUST** be of the type that is specified by the anonymous XSD definition that is contained in this section.
- The **ObjectData** element **MUST** contain a **WmiConnectionManager** element of type [ConnectionManagerObjectDataWmiConnectionManagerType](#).

This anonymous type declaration acts as a replacement for the definition for **ConnectionManagerObjectDataType** type in the case of a WMI data source.

```
<xs:complexType>
  <xs:choice>
    <xs:element name="WmiConnectionManager"
      type="DTS:ConnectionManagerObjectDataWmiConnectionManagerType"/>
  </xs:choice>
</xs:complexType>
```

2.4.5 ExecutableTypePackagePropertyNameEnum

The **ExecutableTypePackagePropertyNameEnum** type contains the values for the **Name** attribute of the property elements that are allowed for the [ExecutableTypePackage](#). The **ExecutableTypePackagePropertyNameEnum** type is a union of the enumeration for the [AllExecutablePropertyNameEnum](#) type with the additional values that are specified in this section.

The following is the XSD for the **ExecutableTypePackagePropertyNameEnum** type.

```
<xs:simpleType name="ExecutableTypePackagePropertyNameEnum">
  <xs:union memberTypes="DTS:AllExecutablePropertyNameEnum">
    <xs:simpleType>
      <xs:restriction base="xs:string">
        <xs:enumeration value="PackageFormatVersion"/>
        <xs:enumeration value="VersionComments"/>
        <xs:enumeration value="CreatorName"/>
        <xs:enumeration value="CreatorComputerName"/>
        <xs:enumeration value="CreationDate"/>
        <xs:enumeration value="PackageType"/>
        <xs:enumeration value="ProtectionLevel"/>
        <xs:enumeration value="MaxConcurrentExecutables"/>
        <xs:enumeration value="PackagePriorityClass"/>
        <xs:enumeration value="VersionMajor"/>
        <xs:enumeration value="VersionMinor"/>
        <xs:enumeration value="VersionBuild"/>
        <xs:enumeration value="VersionGUID"/>
        <xs:enumeration value="EnableConfig"/>
      </xs:restriction>
    </xs:simpleType>
  </xs:union>
</xs:simpleType>
```

```

    <xs:enumeration value="CheckpointFileName"/>
    <xs:enumeration value="SaveCheckpoints"/>
    <xs:enumeration value="CheckpointUsage"/>
    <xs:enumeration value="SuppressConfigurationWarnings"/>
    <xs:enumeration value="LastModifiedProductVersion"/>
  </xs:restriction>
</xs:simpleType>
</xs:union>
</xs:simpleType>

```

The following table specifies the enumeration values for the **ExecutableTypePackagePropertyNameEnum** type.

The **ExecutableTypePackagePropertyNameEnum** type is a union of the **AllExecutablePropertyNameEnum** with the additional values that are specified in this section. The values that are specified in the following table do not include the values that are already specified for **AllExecutablePropertyNameEnum**.

| Property name | Description |
|---------------------------------|---|
| PackageFormatVersion | Specifies the package format version. |
| VersionComments | Specifies text that can be used to store comments about the version. <7> |
| CreatorName | Specifies text that can be used to store the creator name of the package as documentation. <8> |
| CreatorComputerName | Specifies text that serves as documentation of the computer on which the package was created. <9> |
| CreationDate | Specifies the date that the executable was created |
| PackageType | Specifies how the package was created. <10> See section 2.4.5.2 for additional restrictions. |
| ProtectionLevel | Specifies how sensitive information is saved with packages. See section 2.4.5.2 for additional restrictions. |
| MaxConcurrentExecutables | Specifies the maximum number of executables to execute concurrently in the package. Valid values are -1 and any integer greater than or equal to 1. A value of -1 allows the maximum number of concurrently running executables to equal the number of processors plus two. |
| PackagePriorityClass | Specifies the execution priority of the package. See section 2.4.5.3 for additional restrictions. |
| VersionMajor | Specifies the major version of the package. Valid values are integers greater than or equal to 0. |
| VersionMinor | Specifies the minor version of the package. Valid values are integers greater than or equal to 0. |
| VersionBuild | Specifies the build number of the package. Valid values are integers greater than or equal to 0. <11> |
| VersionGUID | Specifies the globally unique identifier (GUID) of the package version. <12> |
| EnableConfig | Specifies whether settings from external configuration setting are accessible to the Executable . |
| CheckpointFileName | Specifies the name of a checkpoint file that a checkpoint-enabled package uses. |

| Property name | Description |
|--------------------------------------|---|
| SaveCheckpoints | Specifies whether the package saves checkpoints. See section 2.4.5.4 for additional restrictions. |
| CheckpointUsage | Specifies whether the package uses checkpoints. See section 2.4.5.5 for additional restrictions. |
| SuppressConfigurationWarnings | Specifies whether configuration warnings are suppressed. See section 2.4.5.7 for additional restrictions. |
| LastModifiedProductVersion | Specifies the latest version of the product that is installed. <13> |

2.4.5.1 Property Name=PackageType

When the **Property** element's **Name** attribute value is **PackageType**, the values that are allowed for the **Property** element are more restricted than the values that are specified by the XSD type definition for the [PropertyElementBaseType](#) complex type. In this case, the allowed values for the **Property** element value MUST be one of the values in the following table.

| Element value | Package type |
|---------------|--------------------|
| 0 | Default |
| 1 | DTS Wizard |
| 2 | DTS Designer |
| 3 | SQL Replication |
| 5 | DTS Designer 100 |
| 6 | SQL DB Maintenance |

2.4.5.2 Property Name=ProtectionLevel

When the **Property** element's **Name** attribute value is **ProtectionLevel**, the values that are allowed for the **Property** element are more restricted than the values that are specified by the XSD type definition for the [PropertyElementBaseType](#) complex type. In this case, the allowed values for the **Property** element value MUST be one of the values in the following table.

For information about how the package file implements user keys or passwords, see [Encryption Implementation for Settings in the ProtectionLevel Property](#).

| Element value | Description |
|---------------|--|
| 0 | Sensitive information is not saved. |
| 1 | Encrypt sensitive information with user key. |
| 2 | Encrypt sensitive information with password. |
| 3 | Encrypt all information with password. |
| 4 | Encrypt all information with user key. |

| Element value | Description |
|---------------|---------------------|
| 5 | Use server storage. |

2.4.5.3 Property Name=PackagePriorityClass

When the **Property** element's **Name** attribute value is **PackagePriorityClass**, the values that are allowed for the **Property** element are more restricted than the values that are specified by the XSD type definition for the [PropertyElementBaseType](#) complex type. In this case, the allowed values for the **Property** element value MUST be one of the values in the following table.

| Element value | Priority for package |
|---------------|----------------------|
| 0 | Default |
| 1 | Above normal |
| 2 | Normal |
| 3 | Below normal |
| 4 | Idle |

2.4.5.4 Property Name=SaveCheckpoints

When the **Property** element's **Name** attribute value is **SaveCheckpoints**, the values that are allowed for the **Property** element are more restricted than the values that are specified by the XSD type definition for the [PropertyElementBaseType](#) complex type. In this case, the allowed values for the **Property** element value MUST be one of the values in the following table.

| Element value | Description |
|---------------|--|
| 0 | False. The saving of checkpoints is not enabled. |
| -1 | True. Checkpoints are enabled. |

2.4.5.5 Property Name=CheckpointUsage

When the **Property** element's **Name** attribute value is **CheckpointUsage**, the values that are allowed for the **Property** element are more restricted than the values that are specified by the XSD type definition for the [PropertyElementBaseType](#) complex type. In this case, the allowed values for the **Property** element value MUST be one of the values in the following table.

| Element value | Description |
|---------------|--------------------------------|
| 0 | Never use checkpoints. |
| 1 | Use checkpoints if they exist. |
| 2 | Always use checkpoints. |

2.4.5.6 Property Name=EnableConfig

When the **Property** element's **Name** attribute value is **EnableConfig**, the values that are allowed for the **Property** element are more restricted than the values that are specified by the XSD type definition for the [PropertyElementBaseType](#) complex type. In this case, the allowed values for the **Property** element value MUST be one of the values in the following table.

| Element value | Description |
|---------------|--|
| 0 | False. Do not use configurations with the package. |
| -1 | True. Use configurations with the package. |

2.4.5.7 Property Name=SuppressConfigurationWarnings

When the **Property** element's **Name** attribute value is **SuppressConfigurationWarnings**, the values that are allowed for the **Property** element are more restricted than the values that are specified by the XSD type definition for the [PropertyElementBaseType](#) complex type. In this case, the allowed values for the **Property** element value MUST be one of the values in the following table.

| Element value | Description |
|---------------|--|
| 0 | False. Do not suppress configuration warnings. |
| -1 | True. Suppress configuration warnings. |

2.5 AnyNonPackageExecutableType

The **AnyNonPackageExecutableType** complex type is the type of an Executable element that is contained within another **Executable** element. That is, it is the type definition for any **Executable** element except the **Executable** element that is the root node of the package.

The following is the XSD for the **AnyNonPackageExecutableType**.

```
<xs:complexType name="AnyNonPackageExecutableType">
  <xs:sequence>
    <xs:element name="ForEachEnumerator"
      type="DTS:ForEachEnumeratorType"
      minOccurs="0"/>
    <xs:element name="Property"
      maxOccurs="unbounded">
      <xs:complexType>
        <xs:complexContent>
          <xs:extension base="DTS:PropertyElementBaseType">
            <xs:attribute name="Name"
              type="DTS:AnyNonPackageExecutablePropertyNameEnum"
              use="required"/>
          </xs:extension>
        </xs:complexContent>
      </xs:complexType>
    </xs:element>
    <xs:element name="Variable" type="DTS:VariableType"
      minOccurs="0" maxOccurs="unbounded"/>
    <xs:element name="LoggingOptions" type="DTS:LoggingOptionsType" />
  </xs:sequence>
</xs:complexType>
```

```

<xs:element name="PropertyExpression"
  type="DTS:PropertyExpressionElementType"
  minOccurs="0" maxOccurs="unbounded"/>
<xs:element name="Executable" type="DTS:AnyNonPackageExecutableType"
  minOccurs="0" maxOccurs="unbounded"/>
<xs:element name="PrecedenceConstraint"
  type="DTS:PrecedenceConstraintType"
  minOccurs="0" maxOccurs="unbounded"/>
<xs:element name="ForEachVariableMapping"
  type="DTS:ForEachVariableMappingType"
  minOccurs="0" maxOccurs="unbounded"/>
<xs:element name="EventHandler" type="DTS:EventHandlerType"
  minOccurs="0" maxOccurs="unbounded"/>
<xs:element name="ObjectData" type="DTS:ExecutableObjectDataType"
  minOccurs="0"/>
</xs:sequence>
<xs:attribute name="ExecutableType" use="required" type="xs:string"/>
<xs:attribute name="ThreadHint" use="optional" type="xs:int"/>
</xs:complexType>

```

The following table provides additional information about the elements, types, and constraints in the **AnyNonPackageExecutableType** complex type.

| Element | Additional constraints | Type definition | Description |
|---------------------------|--|---------------------------------------|--|
| ForEachEnumerator | This element MUST NOT be used unless the ExecutableType attribute is equal to "STOCK:FOREACHLOOP". | ForEachEnumeratorType | Contains information about the iterations of a For...Each loop. |
| Property | In some cases, constraints are placed on the Property element's value for specific values of the Name attribute of the Property element. If such constraints exist, they are specified where the meaning of the particular property name is specified. These constraints MUST be followed. If the optional DataType attribute is present, the value of the Property element MUST be of the type that is specified by the DataType attribute. | Inline in the XSD in this section. | See ExecutableTypePackage . |
| Variable | None. | VariableType | See ExecutableTypePackage. |
| LoggingOptions | None. | LoggingOptionsType | See ExecutableTypePackage. |
| PropertyExpression | Additional constraints exist for the PropertyExpression element. For a description of the constraints, see PropertyExpressionElementType . | PropertyExpressionElementType | See ExecutableTypePackage. |
| Executable | Some values of the | AnyNonPackageExecutableT | See |

| Element | Additional constraints | Type definition | Description |
|-------------------------------|--|--|--|
| | ExecutableType attribute allow further Executable elements to be contained, and other values MUST NOT contain further Executable elements. For more information, see ExecutableType Attribute Values for Different Executable Types . | ype | ExecutableTypePackage. |
| ForEachVariableMapping | This element MUST NOT be used unless the ExecutableType attribute is equal to "STOCK:FOREACHLOOP" | ForEachVariableMappingType | Contains information about the variable mappings for the iterations of a For...Each loop. |
| PrecedenceConstraint | None. | PrecedenceConstraintType | See ExecutableTypePackage. |
| EventHandler | None. | EventHandlerType | See ExecutableTypePackage. |
| ObjectData | Each value of the attribute ExecutableType constrains the choice that is contained in the definition of ExecutableObjectDataType to a specific choice. For more information, see ExecutableType Attribute Values for Different Executable Types. | ExecutableObjectDataType | Contains information specific to the Executable . The nature of the information varies with the value of the ExecutableType attribute. For more information, see Executable ObjectData Types . |

The following table provides additional information about the attributes, types, and constraints in the **AnyNonPackageExecutableType** complex type.

| Attribute | Constraints | Description |
|-----------------------|--|----------------------------|
| ExecutableType | Some values of the ExecutableType attribute allow further Executable elements to be contained, and other values MUST NOT contain further Executable elements. For more information, see ExecutableType Attribute Values for Different Executable Types. | See ExecutableTypePackage. |
| ThreadHint | Not all values of ExecutableType are allowed to have the ThreadHint attribute present. For more information, see ExecutableType Attribute Values for Different Executable Types. | Not applicable. <14> |

The following table provides additional information about the attributes and types for the **Property** element that is declared inline in the complex type declaration. The **Property** element is an extension of the [PropertyElementBaseType](#) type with the addition of the **Name** attribute, which is specified in the following table.

| Attribute | Constraints | Description |
|-------------|-------------|--|
| Name | None. | Specifies the name of the Property element. Each named property has its own use |

| Attribute | Constraints | Description |
|-----------|-------------|---|
| | | and interpretation. The explanation for the interpretation of each named property is given with the definition of the type for the Name attribute. |

2.5.1 ForEachEnumeratorType

The **ForEachEnumeratorType** complex type MUST NOT be used for an executable unless its **ExecutableType** attribute is equal to "STOCK:FOREACHLOOP". The **ForEachEnumeratorType** complex type contains information about the entity to be looped over and the logic of the looping.

The following is the XSD for the **ForEachEnumeratorType** type.

```
<xs:complexType name="ForEachEnumeratorType">
  <xs:sequence>
    <xs:element name="Property"
      maxOccurs="unbounded">
      <xs:complexType>
        <xs:complexContent>
          <xs:extension base="DTS:PropertyElementBaseType">
            <xs:attribute name="Name"
              type="DTS:BasePropertyNameEnum"
              use="required"/>
          </xs:extension>
        </xs:complexContent>
      </xs:complexType>
    </xs:element>
    <xs:element name="PropertyExpression"
      type="DTS:PropertyExpressionElementType"
      minOccurs="0" maxOccurs="unbounded"/>
    <xs:element name="ObjectData"
      type="DTS:ForEachEnumeratorObjectDataType"/>
  </xs:sequence>
</xs:complexType>
```

The following table provides additional information about the elements, types, and constraints in the **ForEachEnumeratorType** complex type.

| Element | Additional constraints | Type definition | Description |
|---------------------------|--|------------------------------------|---|
| Property | In some cases, constraints are placed on the Property element's value for specific values of the Name attribute of the Property element. If such constraints exist, they are specified where the meaning of the particular property name is specified. These constraints MUST be followed. If the optional DataType attribute is present, the value of the Property element MUST be of the type that is specified by the DataType attribute. | Inline in the XSD in this section. | Contains values for many different properties that are associated with an instance of the containing Executable element, according to the Name attribute of each Property element. |
| PropertyExpression | Additional constraints exist for the | PropertyExpressionElementType | Serves the same purpose as described |

| Element | Additional constraints | Type definition | Description |
|-------------------|---|---|--|
| | PropertyExpression element. These constraints MUST be followed. For a description of these constraints, see PropertyExpressionElement Type . | | for the Property element, except that an expression that is evaluated at runtime is contained in the element's value that is stored in the Microsoft SQL Server Integration Services (SSIS) file format |
| ObjectData | None. | ForEachEnumeratorObjectDataType | Contains information that is specific to the ForEachEnumerator . For more information, see Executable ObjectData Types . |

The following table provides additional information about the attributes and types for the **Property** element that is declared inline in the complex type declaration. The **Property** element is an extension of the [PropertyElementBaseType](#) type with the addition of the **Name** attribute, which is specified in the following table.

| Attribute | Description |
|-------------|--|
| Name | Specifies the name of the Property element. Each named property has its own use and interpretation. The explanation for the interpretation of each named property is given with the definition of the type for the Name attribute. |

The **ForEachEnumerator** has no additional values that are allowed for the **Name** attribute of the **Property** element beyond those of the **BasePropertyNameEnum** type. Therefore, no further **Name** attribute enumeration items are described in any subsection to this section.

2.5.1.1 ForEachEnumeratorObjectDataType

The **ForEachEnumeratorObjectDataType** type contains information that is specific to each type of **For...Each** loop.

The following is the XSD of the **ForEachEnumeratorObjectDataType** type.

```
<xs:complexType name="ForEachEnumeratorObjectDataType">
  <xs:choice>
    <xs:element name="FEIEItems" type="DTS:FEIEItemsType"
      form="unqualified"/>
    <xs:element name="ForEachFileEnumeratorProperties"
      type="DTS:ForEachFileEnumeratorPropertiesType"
      form="unqualified"/>
    <xs:element name="FEEADO" type="DTS:FEEADOType"
      form="unqualified"/>
    <xs:element name="FEESchemaRowset" type="DTS:FEESchemaRowsetType"
      form="unqualified"/>
    <xs:element name="FEEFVE" type="DTS:FEEFVEType" form="unqualified"/>
    <xs:element name="FEENODELIST" type="DTS:FEENODELISTType"
      form="unqualified"/>
    <xs:element name="FEESMO" type="DTS:FEESMOType" form="unqualified"/>
  </xs:choice>
</xs:complexType>
```

The following table provides additional information about the elements, types, and constraints in the [ForEachEnumeratorType](#) complex type.

| Element | Additional constraints | Type definition | Description |
|--|-------------------------------|---|---|
| FEIEItems | None | FEIEItemsType | Specifies a collection of items over which enumeration is performed. |
| ForEachFileEnumeratorProperties | None | ForEachFileEnumeratorPropertiesType | Specifies properties for enumeration over a set of files. |
| FEEADO | None | FEEADOType | Specifies properties and parameters for enumeration over the rows of an ADO recordset or over an ADO.NET dataset. |
| FEESchemaRowset | None | FEESchemaRowsetType | Specifies properties and parameters for enumeration over the tables of a database schema. |
| FEFVE | None | FEFVEType | Specifies properties and parameters for enumeration over the content of a variable in the package. |
| FEENODELIST | None | FEENODELISTType | Specifies properties and parameters for enumeration over the nodes in an XML document. |
| FEESMO | None | FEESMOType | Specifies properties and parameters for enumeration over tables in a database schema using an SMO connection. |

2.5.1.1.1 FEIEItemsType

The **FEIEItemsType** complex type specifies a collection of items over which enumeration is performed.

The following is the XSD of the **FEIEItemsType** complex type.

```
<xs:complexType name="FEIEItemsType">
  <xs:sequence>
    <xs:element name="FEIEItem" type="DTS:FEIEItemType"
      maxOccurs="unbounded" form="unqualified"/>
  </xs:sequence>
</xs:complexType>
```

The following table provides additional information about the elements, types, and constraints in the **FEIEItemsType** complex type.

| Element | Additional constraints | Type definition | Description |
|-----------------|------------------------|------------------------------|--|
| FEIEItem | None | FEIEItemType | Specifies an individual item within the collection of items over which enumeration is being performed. |

2.5.1.1.1.1 FEIEItemType

The **FEIEItemType** complex type specifies an individual item within a collection of items over which enumeration is performed.

The following is the XSD of the **FEIEItemType** complex type.

```
<xs:complexType name="FEIEItemType">
  <xs:sequence>
    <xs:element name="FEIEItemValue" maxOccurs="unbounded"
      form="unqualified" type="DTS:FEIEItemValueType"/>
  </xs:sequence>
</xs:complexType>
```

The following table provides additional information about the elements, types, and constraints in the **FEIEItemType** complex type.

| Element | Additional constraints | Type definition | Description |
|----------------------|------------------------|-----------------------------------|--|
| FEIEItemValue | None | FEIEItemValueType | Contains the type of and the value for an individual item in the enumeration collection. |

2.5.1.1.1.1.1 FEIEItemValue Type

The **FEIEItemValueType** complex type specifies the value for an individual FEIEItem item.

The following is the XSD of the **FEIEItemValueType** complex type.

```
<xs:complexType name="FEIEItemValueType">
  <xs:sequence/>
  <xs:attribute name="Type" type="DTS:DtsDataTypeEnum"
    use="required" form="unqualified"/>
</xs:complexType>
```

```

    <xs:attribute name="Value" type="xs:string"
                use="required" form="unqualified"/>
</xs:complexType>

```

The following table provides additional information about the attributes of the **FEIItemValueType**.

| Attribute | Description |
|--------------|--|
| Type | The type of the current instance of the FEIItemValue element. |
| Value | The value of the current instance of the FEIItemValue element. The value of the Value item is interpreted as being of the type that is specified in the Type attribute. |

2.5.1.1.2 ForEachFileEnumeratorPropertiesType

The **ForEachFileEnumeratorPropertiesType** complex type contains the information for enumeration over a set of files.

The following is the XSD of the **ForEachEnumeratorPropertiesType** complex type.

```

<xs:complexType name="ForEachFileEnumeratorPropertiesType">
  <xs:sequence>
    <xs:element name="FEFEProperty" maxOccurs="unbounded" form="unqualified">
      <xs:complexType>
        <xs:sequence/>
        <xs:attribute name="Folder" form="unqualified"/>
        <xs:attribute name="FileSpec" form="unqualified"/>
        <xs:attribute name="FileNameRetrievalType" form="unqualified">
          <xs:simpleType>
            <xs:restriction base="xs:int">
              <xs:minInclusive value="0"/>
              <xs:maxInclusive value="2"/>
            </xs:restriction>
          </xs:simpleType>
        </xs:attribute>
        <xs:attribute name="Recurse" form="unqualified">
          <xs:simpleType>
            <xs:restriction base="xs:int">
              <xs:minInclusive value="-1"/>
              <xs:maxInclusive value="0"/>
            </xs:restriction>
          </xs:simpleType>
        </xs:attribute>
      </xs:complexType>
    </xs:element>
  </xs:sequence>
</xs:complexType>

```

The following table provides additional information about the attributes for the **FEFEProperty** element of the **ForEachFileEnumeratorPropertiesType** type.

| Attribute | Additional constraints | Description |
|-----------------|------------------------|---|
| Folder | None | Specifies a string that contains a folder name over which to enumerate files. |
| FileSpec | None | Specifies a string that contains a file specification. |

| Attribute | Additional constraints | Description |
|------------------------------|------------------------|---|
| FileNameRetrievalType | None | Specifies the nature of the file name retrieval specification, according to integer values in the following list: 0 = A fully qualified file name. 1 = A file name and a file extension is specified. 2 = A file name only is specified. |
| Recurse | None | Specifies whether to traverse all subfolders to search for files that match the file specification according to integer values in the following list: -1 = TRUE, do traverse subfolders. 0 = FALSE, do not traverse subfolders. |

2.5.1.1.3 FEEADOType

The **FEEADOType** complex type specifies enumeration over the rows of an ADO recordset or over an ADO.NET dataset.

The following is the XSD of the **FEEADOType** complex type.

```
<xs:complexType name="FEEADOType">
  <xs:sequence/>
  <xs:attribute name="EnumType" use="required" form="unqualified"
    type="DTS:FEEADOEnumType"/>
  <xs:attribute name="VarName" type="xs:string"
    use="required" form="unqualified"/>
</xs:complexType>
```

The following table provides additional information about the attributes of the **FEEADOType** type.

| Attribute | Additional constraints | Description |
|-----------------|------------------------|---|
| EnumType | None | Specifies the type of enumeration over the tables of a database or over the tables of an ADO.NET dataset to perform. |
| VarName | None | Specifies a string that contains the name of the variable that contains the results over which to form the enumeration. |

2.5.1.1.3.1 FEEADOEnumType

The **FEEADOEnumType** type specifies the enumeration values for the **FEEADO** element.

The following is the XSD of the **FEEADOEnumType** type.

```
<xs:simpleType name="FEEADOEnumType">
  <xs:restriction base="xs:string">
    <xs:enumeration value="EnumerateRowsInFirstTable"/>
    <xs:enumeration value="EnumerateAllRows"/>
    <xs:enumeration value="EnumerateTables"/>
  </xs:restriction>
</xs:simpleType>
```

```
</xs:simpleType>
```

The following table specifies the enumeration values for the [NodelistEnumerationTypeEnum](#) type.

| Enumeration value | Description |
|----------------------------------|--|
| EnumerateRowsInFirstTable | Enumerate over the row values in only the first table. |
| EnumerateAllRows | Enumerate over all rows in all tables. |
| EnumerateTables | Enumerate over each table. |

2.5.1.1.4 FEESchemaRowsetType

The **FEESchemaRowsetType** complex type specifies enumeration over tables in a database schema.

The following is the XSD of the **FEESchemaRowsetType** complex type.

```
<xs:complexType name="FEESchemaRowsetType">
  <xs:sequence>
    <xs:element name="Restriction" maxOccurs="unbounded"
      form="unqualified" type="DTS:RestrictionElementType"/>
  </xs:sequence>
  <xs:attribute name="Connection" type="xs:string"
    use="required" form="unqualified"/>
  <xs:attribute name="Schema" type="DTS:uuid"
    use="required" form="unqualified"/>
</xs:complexType>
```

The following table provides additional information about the elements, types, and constraints in the **ForEachEnumeratorType** complex type.

| Element | Additional constraints | Type definition | Description |
|--------------------|------------------------|--|--|
| Restriction | None | RestrictionElementType | Specifies a restriction on the schema rowset. The enumeration occurs with the result after application of the restriction. |

The following table provides additional information about the attributes of the **FEEADOType** type.

| Attribute | Additional constraints | Description |
|-------------------|------------------------|--|
| Connection | None | Specifies a string that contains the connection to schema for enumeration. |
| Schema | None | Specifies the GUID of the schema that is desired for the enumeration |

2.5.1.1.4.1 RestrictionElementType

The **RestrictionElementType** complex type specifies a restriction that is applied against a schema.

The following is the XSD of the **RestrictionElementType** complex type.

```

<xs:complexType name="RestrictionElementType">
  <xs:sequence/>
  <xs:attribute name="Index" type="xs:int" use="required"
    form="unqualified"/>
  <xs:attribute name="Value" type="xs:string" use="required"
    form="unqualified"/>
</xs:complexType>

```

The **RestrictionElementType** contains no elements.

The following table provides additional information about the attributes of the **RestrictionElementType** type.

| Attribute | Additional constraints | Description |
|--------------|------------------------|--|
| Index | None | An integer that represents the index number of this restriction. |
| Value | None | A string that is the value for this restriction. |

2.5.1.1.5 FEEFVEType

The **FEEFVEType** complex type specifies enumeration over values that are contained in a variable.

The following is the XSD for the **FEEFVEType** complex type.

```

<xs:complexType name="FEEFVEType">
  <xs:sequence/>
  <xs:attribute name="VariableName" type="xs:string"
    form="unqualified" use="required"/>
</xs:complexType>

```

The **FEEFVEType** type contains no elements.

The following table provides additional information about the attributes for the **FEEFVEType** complex type.

| Attribute | Description |
|---------------------|--|
| VariableName | A string that specifies the name of the variable which contains the information over which the For...Each enumeration is performed. |

2.5.1.1.6 FEENODELISTType

The **FEENODELISTType** complex type specifies enumeration over a list of XML nodes that is obtained by applying an XPATH expression to an XML file.

The following is the XSD for the **FEENODELISTType** complex type.

```

<xs:complexType name="FEENODELISTType">
  <xs:sequence/>
  <xs:attribute name="EnumerationType"
    type="DTS:NodelistEnumerationTypeEnum"
    form="unqualified" use="required"/>
  <xs:attribute name="OuterXPathSourceType" form="unqualified"

```

```

        use="required" type="DTS:SourceTypeEnum"/>
<xs:attribute name="OuterXPathString" type="xs:string"
form="unqualified" use="required"/>
<xs:attribute name="InnerElementType"
type="DTS:NodelistInnerElementEnumerationTypeEnum"
use="required" form="unqualified"/>
<xs:attribute name="InnerXPathSourceType" form="unqualified"
use="required" type="DTS:SourceTypeEnum"/>
<xs:attribute name="InnerXPathString" type="xs:string"
form="unqualified" use="required"/>
<xs:attribute name="SourceType" form="unqualified"
use="required" type="DTS:SourceTypeEnum"/>
<xs:attribute name="SourceDocument" type="xs:string"
use="required" form="unqualified"/>
</xs:complexType>

```

The **FEENODELISTType** type contains no elements.

The following table provides additional information about the attributes for the **FEENODELISTType** complex type.

| Attribute | Description |
|-----------------------------|--|
| EnumerationType | Specifies the type of the enumeration. |
| OuterXPathSourceType | Specifies the source type for the XPath [XPATH] string. |
| OuterXPathString | Specifies a string that contains an XPATH expression that is applied to an XML file to obtain the nodes over which enumeration occurs. |
| InnerElementType | Specifies the type of enumeration for the inner element. The InnerElementType applies only if the EnumerationType attribute is set to "ElementCollection". |
| InnerXPathSourceType | Specifies the source type for the inner XPath string. |
| SourceType | Specifies the source of the XML. |
| SourceDocument | Specifies a string that contains the name of the source document for the XML. |

2.5.1.1.6.1 NodelistEnumerationTypeEnum

The **NodelistEnumerationTypeEnum** type contains enumeration values that are used to set the type the enumeration over nodes.

The following is the XSD for the **NodelistEnumerationTypeEnum** type.

```

<xs:simpleType name="NodelistEnumerationTypeEnum">
  <xs:restriction base="xs:string">
    <xs:enumeration value="Navigator"/>
    <xs:enumeration value="Node"/>
    <xs:enumeration value="NodeText"/>
    <xs:enumeration value="ElementCollection"/>
  </xs:restriction>
</xs:simpleType>

```

The following table specifies the enumeration values for the **NodelistEnumerationTypeEnum** type.

| Enumeration value | Description |
|--------------------------|--|
| Navigator | Enumerate using an XPathNavigator object. |
| Node | Enumerate nodes that are returned by an XPath operation. |
| NodeText | Enumerate text nodes that are returned by an XPath operation. |
| ElementCollection | Enumerate element nodes that are returned by an XPath operation. |

2.5.1.1.6.2 NodelistInnerElementEnumerationTypeEnum

The **NodelistInnerElementEnumerationTypeEnum** type contains enumeration values that are used to set the type the enumeration over inner element nodes.

The following is the XSD for the **NodelistInnerElementEnumerationTypeEnum** type.

```
<xs:simpleType name="NodelistInnerElementEnumerationTypeEnum">
  <xs:restriction base="xs:string">
    <xs:enumeration value="Navigator"/>
    <xs:enumeration value="Node"/>
    <xs:enumeration value="NodeText"/>
  </xs:restriction>
</xs:simpleType>
```

The following table specifies the enumeration values for the **NodelistInnerElementEnumerationTypeEnum** type.

| Enumeration value | Description |
|-------------------|---|
| Navigator | Enumerate using an XPathNavigator object. |
| Node | Enumerate nodes that are returned by an XPath operation. |
| NodeText | Enumerate text nodes that are returned by an XPath operation. |

2.5.1.1.7 FEESMOType

The **FEESMOType** complex type derives enumeration over an SMO object.

The following is the XSD for the **FEESMOType** complex type.

```
<xs:complexType name="FEESMOType">
  <xs:sequence/>
  <xs:attribute name="EnumURN" type="xs:string"
    form="unqualified" use="required"/>
</xs:complexType>
```

The **FEESMOType** type contains no elements.

The following table provides additional information about the attributes for the **FEESMOType** complex type.

| Attribute | Description |
|-----------|---|
| EnumURN | A string that specifies the content of the SMO object to enumerate. |

2.5.2 ForEachVariableMappingType

The **ForEachVariableMappingType** complex type MUST NOT be used for an executable unless its **ExecutableType** attribute value is equal to "STOCK:FOREACHLOOP". It contains information about the variable mapping for a **For...Each** enumeration.

The following is the XSD for the **ForEachVariableMappingType** type.

```
<xs:complexType name="ForEachVariableMappingType" >
  <xs:sequence>
    <xs:element name="Property"
      maxOccurs="unbounded">
      <xs:complexType>
        <xs:complexContent>
          <xs:extension base="DTS:PropertyElementBaseType">
            <xs:attribute name="Name"
              type="DTS:ForEachVariableMappingPropertyNameEnum"
              use="required"/>
          </xs:extension>
        </xs:complexContent>
      </xs:complexType>
    </xs:element>
    <xs:element name="PropertyExpression"
      type="DTS:PropertyExpressionElementType"
      minOccurs="0" maxOccurs="unbounded"/>
  </xs:sequence>
</xs:complexType>
```

The following table provides additional information about the elements, types, and constraints in the **ForEachVariableMappingType** complex type.

| Element | Additional constraints | Type definition | Description |
|---------------------------|--|------------------------------------|--|
| Property | In some cases, constraints are placed on the Property element's value for specific values of the Name attribute of the Property element. If such constraints exist, they are specified where the meaning of the particular property name is specified. These constraints MUST be followed. If the optional Data Type attribute is present, the value of the Property element MUST be of the type indicated by the Data Type attribute. | Inline in the XSD in this section. | Property elements contain values for many different properties that are associated with an instance of the containing Executable element, according to the Name attribute of each Property element. |
| PropertyExpression | Additional constraints exist for the PropertyExpression element. These constraints MUST be followed. For a description of these constraints, see | PropertyExpressionElementType | The PropertyExpression element serves the same purpose as specified for the Property element |

| Element | Additional constraints | Type definition | Description |
|---------|---|-----------------|--|
| | PropertyExpressionElementTy pe . | | except that an expression that is evaluated at runtime is contained in the element's value that is stored in the Microsoft SQL Server Integration Services (SSIS) file format. |

The following table provides additional information about the attributes and types for the **Property** element that is declared inline in the complex type declaration. The **Property** element is an extension of the [PropertyElementBaseType](#) type with the addition of the **Name** attribute, which is specified in the following table.

| Attribute | Description |
|-------------|--|
| Name | Specifies the name of the Property element. Each named property has its own use and interpretation. The explanation for the interpretation of each named property is given with the definition of the type for the Name attribute. |

2.5.2.1 ForEachVariableMappingPropertyNameEnum

The **ForEachVariableMappingPropertyNameEnum** type contains the values for the **Name** attribute of the **Property** elements that are allowed for the [ForEachVariableMappingType](#) type.

The following is the XSD for the **ForEachVariableMappingPropertyNameEnum** type.

```
<xs:simpleType name="ForEachVariableMappingPropertyNameEnum">
  <xs:union memberTypes="DTS:BasePropertyNameEnum">
    <xs:simpleType>
      <xs:restriction base="xs:string">
        <xs:enumeration value="VariableName"/>
        <xs:enumeration value="ValueIndex"/>
      </xs:restriction>
    </xs:simpleType>
  </xs:union>
</xs:simpleType>
```

The following table specifies the enumeration values for the **ForEachVariableMappingPropertyNameEnum** type. The **ForEachVariableMappingPropertyNameEnum** type is a union of the [BasePropertyNameEnum](#) type with the additional values described in this section. The values that are specified in this table do not include the values that are already described for **BasePropertyNameEnum**.

| Enumeration value | Description |
|---------------------|--|
| VariableName | The name of the variable to be mapped to the For...Each loop. |
| ValueIndex | An integer that expresses the order of the variables. 0 based. |

2.5.3 AnyNonPackageExecutableTypePropertyNameEnum

The **AnyNonPackageExecutableTypePropertyNameEnum** type contains the values for the **Name** attribute of the property element that are allowed for executable type [ExecutableTypePackage](#). It is a union of the enumeration values that are allowed on all **Executable** types with the additional values that are specified in this section.

The following is the XSD for the **AnyNonPackageExecutableTypePropertyNameEnum** type.

```
<xs:simpleType name="AnyNonPackageExecutablePropertyNameEnum">
  <xs:union memberTypes="DTS:AllExecutablePropertyNameEnum">
    <xs:simpleType>
      <xs:restriction base="xs:string">
        <!--Pipeline & Tasks use these values-->
        <xs:enumeration value="ExecutionLocation"/>
        <xs:enumeration value="ExecutionAddress"/>
        <xs:enumeration value="TaskContact"/>
        <xs:enumeration value="SqlStatementSource"/>
        <!--ForLoop uses these values-->
        <xs:enumeration value="InitExpression"/>
        <xs:enumeration value="EvalExpression"/>
        <xs:enumeration value="AssignExpression"/>
        <!--ForLoop and ForEachLoop use this value-->
        <xs:enumeration value="MaxConcurrent"/>
        <!--Sequence uses this value-->
        <xs:enumeration value="LockName"/>
        <!--Web Service Task uses this value-->
        <xs:enumeration value="WsdFile"/>
      </xs:restriction>
    </xs:simpleType>
  </xs:union>
</xs:simpleType>
```

The following table specifies the enumeration values for the **AnyNonPackageExecutableTypePropertyNameEnum** type. Note that additional restrictions on the use of specific enumeration values of this enumeration **MUST** be followed. These additional restrictions are noted in the following table.

| Property name | Description |
|---------------------------|--|
| ExecutionLocation | This value SHOULD be set to 0. <15> |
| ExecutionAddress | This value SHOULD be set to EMPTY. <16> |
| TaskContact | Holds information about the contact point for this package. Intended to be helpful in support of the package. This Name attribute value cannot be used for all executables of type AnyNonPackageExecutableType . The use of this value depends on the value of the attribute on the Executable element, ExecutableType . For more information about which ExecutableType executables cannot have this attribute value specified, see ExecutableType Attribute Values for Different Executable Types . |
| SqlStatementSource | String that contains the source of a Structured Query Language (SQL) statement. |
| InitExpression | Specifies an expression to initialize a loop. This Name attribute value cannot be used for all executables of type AnyNonPackageExecutableType . The use of the InitExpression value depends on the value of the attribute on the Executable element, ExecutableType . For more information about which ExecutableType executables cannot have this attribute value specified, see ExecutableType Attribute Values for Different Executable Types. |
| EvalExpression | Specifies an expression to evaluate to determine whether a loop continues to execute. This Name attribute value cannot be used for all executables of type AnyNonPackageExecutableType . The use of this value depends on the value of the |

| Property name | Description |
|-------------------------|---|
| | attribute on the Executable element, ExecutableType . For more information about which ExecutableType executables cannot have this attribute value specified, see ExecutableType Attribute Values for Different Executable Types. |
| AssignExpression | Specifies the expression to evaluate at the end of each iteration of the loop. This Name attribute value cannot be used for all executables of type AnyNonPackageExecutableType . The use of the AssignExpression value depends on the value of the attribute on the Executable element, ExecutableType . For more information about which ExecutableType executables cannot have this attribute value specified, see ExecutableType Attribute Values for Different Executable Types. |
| MaxConcurrent | This value SHOULD be set to 1. <17> |
| LockName | This value SHOULD be left blank. <18> |
| WsdFile | The name of the Web Services Description Language (WSDL) file to be used for the web service. |

2.6 ExecutableType Attribute Values for Different Executable Types

The value of the **ExecutableType** attribute of the Executable element carries with it important constraints, which are not fully expressed in the XSD code fragments. These additional constraints MUST be followed for each value of the **ExecutableType** attribute. These additional constraints are explained in this section. The important differences that vary by value of the **ExecutableType** attribute are the following:

- Allowed values for the **Name** attribute of the **Property** element differ for different values of the **ExecutableType** attribute. The same limitations apply to the **PropertyExpression** element within the same **ExecutableType** instance.
- The choice that is contained within the complex type definition for [ExecutableObjectDataType](#) is also constrained by this value. Not all of the choices in the XSD are available for each **ExecutableType** attribute value.
- Some **ExecutableType** attribute values allow an **Executable** element to be contained within the current **Executable** element, and others do not allow an **Executable** element to be contained within the current **Executable** element.

2.6.1 ExecutableType Instance for Pipeline Task

Pipeline Task maps a data flow from an origin to a destination by passing the data flow through a series of components. An Executable element is a Pipeline Task if the **ExecutableType** attribute value is one of the following:

- SSIS.Pipeline
- SSIS.Pipeline.2

The Pipeline Task is formally specified to be of type [AnyNonPackageExecutableType](#). However, the following XSD fragment, which is expressed as an anonymous complex type declaration, places further restrictions on the type than the restrictions that are declared in the **AnyNonPackageExecutableType** type declaration. An **Executable** element with the **ExecutableType** attribute value equal to "SSIS.Pipeline" or "SSIS.Pipeline.2" MUST follow the anonymous type declaration that is contained in this section.

Note the following differences between this anonymous complex type declaration and the full definition of the complex type for the **AnyNonPackageExecutableType** type:

- This **Executable** element MUST NOT contain a **ForEachEnumerator** element.
- This **Executable** element MUST NOT contain a **ForEachVariableMapping** element.
- This **Executable** element MUST NOT contain a child **Executable** element.
- In the **AnyNonPackageExecutableType** type, the type of the **ObjectData** element is given as [ExecutableObjectDataType](#). The **ExecutableObjectDataType** type definition contains an **xs:choice** XSD Schema element. However, for the Pipeline Task, not all of the choices that are allowed in the **xs:choice** XSD Schema element are available. For this **Executable** element, the **ObjectData** element MUST contain the **pipeline** element of type [pipelineObjectDataType](#).
- The allowed values for the **Name** attribute of the **Property** element are a restricted subset of those that are allowed on the type, as specified in the [AnyNonPackageExecutablePropertyNameEnum](#) type. Therefore, the formal type declaration of the **Property** element and the **PropertyExpression** elements are replaced in this anonymous XSD fragment with a reference to the [TaskExePropertyNameEnum](#) simple type. The **Name** attribute of the **Property** element MUST be restricted to the values that are shown as valid in the XSD fragment that is contained in this section.

```
<xs:complexType>
  <xs:sequence>
    <xs:element name="ForEachEnumerator"
      type="DTS:ForEachEnumeratorType"
      minOccurs="0" maxOccurs="0"/>
    <xs:element name="Property"
      maxOccurs="unbounded">
      <xs:complexType>
        <xs:complexContent>
          <xs:extension base="DTS:PropertyElementBaseType">
            <xs:attribute name="Name"
              type="DTS:TaskExePropertyNameEnum"
              use="required"/>
          </xs:extension>
        </xs:complexContent>
      </xs:complexType>
    </xs:element>
    <xs:element name="Variable" type="DTS:VariableType"
      minOccurs="0" maxOccurs="unbounded"/>
    <xs:element name="LoggingOptions" type="DTS:LoggingOptionsType" />
    <xs:element name="PropertyExpression"
      type="DTS:PropertyExpressionElementType"
      minOccurs="0" maxOccurs="unbounded"/>
    <xs:element name="PrecedenceConstraint"
      type="DTS:PrecedenceConstraintType"
      minOccurs="0" maxOccurs="unbounded"/>
    <xs:element name="ForEachVariableMapping"
      type="DTS:ForEachVariableMappingType"
      minOccurs="0" maxOccurs="0"/>
    <xs:element name="EventHandler" type="DTS:EventHandlerType"
      minOccurs="0" maxOccurs="unbounded"/>
    <xs:element name="ObjectData">
      <xs:complexType>
        <xs:choice>
          <xs:element name="pipeline"
            type="DTS:pipelineObjectDataType"
            form="unqualified"/>
        </xs:choice>
      </xs:complexType>
    </xs:element>
  </xs:sequence>
  <xs:attribute name="ExecutableType" use="required">
    <xs:simpleType>
```

```

    <xs:restriction base="xs:string">
      <xs:enumeration value="SSIS.Pipeline.2"/>
      <xs:enumeration value="SSIS.Pipeline"/>
    </xs:restriction>
  </xs:simpleType>
</xs:attribute>
<xs:attribute name="ThreadHint" use="optional" type="xs:int"/>
</xs:complexType>

```

2.6.2 Executable Container Types

Executable Container types are not a formal type within the XSD. They are a conceptual subdivision of the values for the **ExecutableType** attribute on the Executable element that is specified by the [AnyNonPackageExecutableType](#) type. The **Executable** elements that are specified in the following subsections can contain additional executables that are nested within an instance of themselves.

2.6.2.1 ExecutableType Instance for Sequence

Sequence executable is a task that serves as a container for other tasks that are executed in a defined sequence. An executable is a Sequence executable if the **ExecutableType** attribute value is "STOCK:SEQUENCE".

The Sequence executable is formally specified to be of type [AnyNonPackageExecutableType](#). However, the following XSD fragment, which is expressed as an anonymous complex type declaration, places further restrictions on the type than the restrictions that are declared in the **AnyNonPackageExecutableType** type declaration. An Executable element with the **ExecutableType** attribute value equal to "STOCK:SEQUENCE" MUST follow the anonymous type declaration that is contained in this section.

Note the following differences between this anonymous complex type declaration and the full definition of the complex type for the **AnyNonPackageExecutableType** type:

- This **Executable** element MUST NOT contain an **ObjectData** element.
- This **Executable** element MUST NOT contain a **ForEachEnumerator** element.
- This **Executable** element MUST NOT contain a **ForEachVariableMapping** element.
- This **Executable** element MUST NOT contain the **ThreadHint** attribute.
- The allowed values for the **Name** attribute of the **Property** element are a restricted subset of the values that are allowed on the type, as specified in the **AnyNonPackageExecutablePropertyNameEnum** type. Hence, the formal type declaration of the **Property** element is replaced in this anonymous XSD fragment with an inline union of the **Name** attribute values that are allowed for the [AllExecutablePropertyNameEnum](#), with the additional values that are specified inline in this anonymous type definition. The **Name** attribute of the **Property** element MUST be restricted to the values that are specified as valid in the XSD fragment that is contained in this section.

```

<xs:complexType>
  <xs:sequence>
    <xs:element name="ForEachEnumerator"
      type="DTS:ForEachEnumeratorType"
      minOccurs="0" maxOccurs="0"/>
    <xs:element name="Property"
      maxOccurs="unbounded">
      <xs:complexType>
        <xs:complexContent>
          <xs:extension base="DTS:PropertyElementBaseType">

```

```

        <xs:attribute name="Name" use="required">
          <xs:simpleType>
            <xs:union
              memberTypes="DTS:AllExecutablePropertyNameEnum">
              <xs:simpleType>
                <xs:restriction base="xs:string">
                  <xs:enumeration value="LockName"/>
                </xs:restriction>
              </xs:simpleType>
            </xs:union>
          </xs:simpleType>
        </xs:attribute>
      </xs:extension>
    </xs:complexContent>
  </xs:complexType>
</xs:element>
<xs:element name="Variable" type="DTS:VariableType"
  maxOccurs="unbounded"/>
<xs:element name="LoggingOptions" type="DTS:LoggingOptionsType" />
<xs:element name="PropertyExpression"
  type="DTS:PropertyExpressionElementType"
  minOccurs="0" maxOccurs="unbounded"/>
<xs:element name="Executable" type="DTS:AnyNonPackageExecutableType"
  minOccurs="0" maxOccurs="unbounded"/>
<xs:element name="PrecedenceConstraint"
  type="DTS:PrecedenceConstraintType"
  minOccurs="0" maxOccurs="unbounded"/>
<xs:element name="ForEachVariableMapping"
  type="DTS:ForEachVariableMappingType"
  minOccurs="0" maxOccurs="0"/>
<xs:element name="EventHandler" type="DTS:EventHandlerType"
  minOccurs="0" maxOccurs="unbounded"/>
<xs:choice minOccurs="0" maxOccurs="0">
  <xs:element name="ObjectData"/>
</xs:choice>
</xs:sequence>
<xs:attribute name="ExecutableType" use="required"
  fixed="STOCK:SEQUENCE"/>
</xs:complexType>

```

2.6.2.2 ExecutableType Instance for ForEachLoop

ForEach executable defines a repeating control flow in a package. The loop implementation is similar to a ForEach looping structure in programming languages. An executable is a ForEach executable if the **ExecutableType** attribute value is "STOCK:FOREACHLOOP".

The ForEach executable is formally defined to be of type [AnyNonPackageExecutableType](#). However, the following XSD fragment, which is expressed as an anonymous complex type declaration, places further restrictions on the type than the restrictions that are declared in the **AnyNonPackageExecutableType** type declaration. An **Executable** element with the **ExecutableType** attribute value equal to "STOCK:FOREACHLOOP" MUST follow the anonymous type declaration that is contained in this section.

Note the following differences between this anonymous complex type declaration and the full definition of the complex type for the **AnyNonPackageExecutableType** type.

- This **Executable** element MUST NOT contain an **ObjectData** element.
- This **Executable** element MUST NOT contain the **ThreadHint** attribute.
- The allowed values for the **Name** attribute of the **Property** element are a restricted subset of the values that are allowed on the type, as specified in the **AnyNonPackageExecutablePropertyNameEnum** type. Hence, the formal type declaration of the **Property** element is replaced in this anonymous XSD fragment with an inline union of the

Name attribute values that are allowed for the [AllExecutablePropertyNameEnum](#) with the additional values that are specified inline in this anonymous type definition. The **Name** attribute of the **Property** element MUST be restricted to the values that are shown as valid in the XSD fragment that is contained in this section.

For more information about the elements, attributes, and enumeration values in the following XSD fragment, see section 2.5.

```
<xs:complexType>
  <xs:sequence>
    <xs:element name="ForEachEnumerator"
      type="DTS:ForEachEnumeratorType"
      minOccurs="1" maxOccurs="unbounded"/>
    <xs:element name="Property"
      maxOccurs="unbounded">
      <xs:complexType>
        <xs:complexContent>
          <xs:extension base="DTS:PropertyElementBaseType">
            <xs:attribute name="Name" use="required">
              <xs:simpleType>
                <xs:union memberTypes=
                  "DTS:AllExecutablePropertyNameEnum">
                  <xs:simpleType>
                    <xs:restriction base="xs:string">
                      <xs:enumeration value="MaxConcurrent"/>
                    </xs:restriction>
                  </xs:simpleType>
                </xs:union>
              </xs:simpleType>
            </xs:attribute>
          </xs:extension>
        </xs:complexContent>
      </xs:complexType>
    </xs:element>
    <xs:element name="Variable" type="DTS:VariableType"
      maxOccurs="unbounded"/>
    <xs:element name="LoggingOptions" type="DTS:LoggingOptionsType"/>
    <xs:element name="PropertyExpression"
      type="DTS:PropertyExpressionElementType"
      minOccurs="0" maxOccurs="unbounded"/>
    <xs:element name="Executable" type="DTS:AnyNonPackageExecutableType"
      minOccurs="0" maxOccurs="unbounded"/>
    <xs:element name="ForEachVariableMapping"
      type="DTS:ForEachVariableMappingType"
      minOccurs="1" maxOccurs="unbounded"/>
    <xs:element name="PrecedenceConstraint"
      type="DTS:PrecedenceConstraintType"
      minOccurs="0" maxOccurs="unbounded"/>
    <xs:element name="EventHandler" type="DTS:EventHandlerType"
      minOccurs="0" maxOccurs="unbounded"/>
    <xs:choice minOccurs="0" maxOccurs="0">
      <xs:element name="ObjectData"/>
    </xs:choice>
  </xs:sequence>
  <xs:attribute name="ExecutableType" use="required"
    fixed="STOCK:FOREACHLOOP"/>
</xs:complexType>
```

2.6.2.3 ExecutableType Instance for ForLoop

ForLoop executable defines a repeating control flow in a package. The loop implementation is similar to a For looping structure in programming languages. An executable is a ForLoop executable if the **ExecutableType** attribute value is "STOCK:FORLOOP".

The Sequence executable is formally defined to be of type [AnyNonPackageExecutableType](#). However, the following XSD fragment, which is expressed as an anonymous complex type declaration, places further restrictions on the type than the restrictions that are declared in the **AnyNonPackageExecutableType** type declaration. An Executable element with the **ExecutableType** attribute value equal to "STOCK:FORLOOP" MUST follow the anonymous type declaration that is contained in this section.

Note the following differences between this anonymous complex type declaration and the full definition of the complex type for the **AnyNonPackageExecutableType** type:

- This **Executable** element MUST NOT contain an **ObjectData** element.
- This **Executable** element MUST NOT contain a **ForEachEnumerator** element.
- This **Executable** element MUST NOT contain a **ForEachVariableMapping** element.
- This **Executable** element MUST NOT contain the **ThreadHint** attribute.
- The allowed values for the **Name** attribute of the **Property** element are a restricted subset of the values that are allowed on the type, as specified in the **AnyNonPackageExecutablePropertyNameEnum** type. Hence, the formal type declaration of the **Property** element is replaced in this anonymous XSD fragment with an inline union of the **Name** attribute values that are allowed for the [AllExecutablePropertyNameEnum](#) type with the additional values that are specified inline in this anonymous type definition. The **Name** attribute of the **Property** element MUST be restricted to the values that are shown as valid in the XSD fragment that is contained in this section.

```
<xs:complexType>
  <xs:sequence>
    <xs:element name="ForEachEnumerator"
      type="DTS:ForEachEnumeratorType"
      minOccurs="0" maxOccurs="0"/>
    <xs:element name="Property"
      maxOccurs="unbounded">
      <xs:complexType>
        <xs:complexContent>
          <xs:extension base="DTS:PropertyElementBaseType">
            <xs:attribute name="Name" use="required">
              <xs:simpleType>
                <xs:union
                  memberTypes="DTS:AllExecutablePropertyNameEnum">
                  <xs:simpleType>
                    <xs:restriction base="xs:string">
                      <xs:enumeration value="InitExpression"/>
                      <xs:enumeration value="EvalExpression"/>
                      <xs:enumeration value="AssignExpression"/>
                      <xs:enumeration value="MaxConcurrent"/>
                    </xs:restriction>
                  </xs:simpleType>
                </xs:union>
              </xs:simpleType>
            </xs:attribute>
          </xs:extension>
        </xs:complexContent>
      </xs:complexType>
    </xs:element>
    <xs:element name="Variable" type="DTS:VariableType"
      maxOccurs="unbounded"/>
    <xs:element name="LoggingOptions" type="DTS:LoggingOptionsType"/>
    <xs:element name="PropertyExpression"
      type="DTS:PropertyExpressionElementType"
      minOccurs="0" maxOccurs="unbounded"/>
    <xs:element name="Executable" type="DTS:AnyNonPackageExecutableType"
      minOccurs="0" maxOccurs="unbounded"/>
    <xs:element name="PrecedenceConstraint"
```



```

        type="DTS:PrecedenceConstraintType"
        minOccurs="0" maxOccurs="unbounded"/>
    <xs:element name="ForEachVariableMapping"
        type="DTS:ForEachVariableMappingType"
        minOccurs="0" maxOccurs="0"/>
    <xs:element name="EventHandler" type="DTS:EventHandlerType"
        minOccurs="0" maxOccurs="unbounded"/>
    <xs:choice minOccurs="0" maxOccurs="0">
        <xs:element name="ObjectData"/>
    </xs:choice>
</xs:sequence>
<xs:attribute name="ExecutableType" use="required"
    fixed="STOCK:FORLOOP"/>
</xs:complexType>

```

2.6.3 Executable Task Types

Executable Task types are not a formal type within the XSD. They are a conceptual subdivision of the values for the **ExecutableType** attribute on the Executable element that is specified by the [AnyNonPackageExecutableType](#) type. The **Executable** elements that are specified in the following subsections MUST NOT contain additional executables nested within an instance of themselves.

2.6.3.1 ExecutableType Instance for ActiveX Script Task

ActiveX Script Task executes code written as an ActiveX script. An executable is an ActiveX Script Task executable if the **ExecutableType** attribute value is one of the following:

- Microsoft.SqlServer.Dts.Tasks.ActiveXScriptTask.ActiveXScriptTask, Microsoft.SqlServer.ActiveXScriptTask, Version=10.0.0.0, Culture=neutral, PublicKeyToken=89845dcd8080cc91
- STOCK:ActiveXScriptTask

The ActiveX Script Task executable is formally defined to be of type [AnyNonPackageExecutableType](#). However, the following XSD fragment, which is expressed as an anonymous complex type declaration, places further restrictions on the type than the restrictions that are declared in the **AnyNonPackageExecutableType** type declaration. An Executable element with the **ExecutableType** attribute value equal to "Microsoft.SqlServer.Dts.Tasks.ActiveXScriptTask.ActiveXScriptTask, Microsoft.SqlServer.ActiveXScriptTask, Version=10.0.0.0, Culture=neutral, PublicKeyToken=89845dcd8080cc91" or "STOCK:ActiveXScriptTask" MUST follow the anonymous type declaration that is contained in this section.

Note the following differences between this anonymous complex type declaration and the full definition of the complex type for the **AnyNonPackageExecutableType** type:

- This **Executable** element MUST NOT contain an **Executable** element.
- This **Executable** element MUST NOT contain a **ForEachEnumerator** element.
- This **Executable** element MUST NOT contain a **ForEachVariableMapping** element.
- In the **AnyNonPackageExecutableType** type, the type of the **ObjectData** element is given as [ExecutableObjectDataType](#). The **ExecutableObjectDataType** type definition contains an **xs:choice** XSD Schema element. However, not all of the choices that are allowed in the **xs:choice** XSD Schema element are available for the ActiveX Script Task executable. For the ActiveX Script Task executable element, the **ObjectData** element MUST contain the **ActiveXScriptTask:ActiveXScriptTaskData** element that is specified in the [ActiveXScriptTask](#) namespace.

- The allowed values for the **Name** attribute of the **Property** element are a restricted subset of the values that are allowed on the type, as specified in the **AnyNonPackageExecutablePropertyNameEnum** type. Hence, the formal type declaration of the **Property** element and the **PropertyExpression** elements are replaced in this anonymous XSD fragment with a reference to the [TaskExePropertyNameEnum](#) simple type. The **Name** attribute of the **Property** element MUST be restricted to the values that are shown as valid in the XSD fragment that is contained in **TaskExePropertyNameEnum** section.

For more information about the elements, attributes, and enumeration values in the following XSD fragment, see section 2.5.

```

<xs:complexType>
  <xs:sequence>
    <xs:element name="ForEachEnumerator"
      type="DTS:ForEachEnumeratorType"
      minOccurs="0" maxOccurs="0"/>
    <xs:element name="Property"
      maxOccurs="unbounded">
      <xs:complexType>
        <xs:complexContent>
          <xs:extension base="DTS:PropertyElementBaseType">
            <xs:attribute name="Name"
              type="DTS:TaskExePropertyNameEnum"
              use="required"/>
          </xs:extension>
        </xs:complexContent>
      </xs:complexType>
    </xs:element>
    <xs:element name="Variable" type="DTS:VariableType"
      minOccurs="0" maxOccurs="unbounded"/>
    <xs:element name="LoggingOptions" type="DTS:LoggingOptionsType" />
    <xs:element name="PropertyExpression"
      type="DTS:PropertyExpressionElementType"
      minOccurs="0" maxOccurs="unbounded"/>
    <xs:element name="PrecedenceConstraint"
      type="DTS:PrecedenceConstraintType"
      minOccurs="0" maxOccurs="unbounded"/>
    <xs:element name="ForEachVariableMapping"
      type="DTS:ForEachVariableMappingType"
      minOccurs="0" maxOccurs="0"/>
    <xs:element name="EventHandler" type="DTS:EventHandlerType"
      minOccurs="0" maxOccurs="unbounded"/>
    <xs:element name="ObjectData">
      <xs:complexType>
        <xs:choice>
          <xs:element ref="ActiveXScriptTask:ActiveXScriptTaskData" />
        </xs:choice>
      </xs:complexType>
    </xs:element>
  </xs:sequence>
  <xs:attribute name="ExecutableType" use="required">
    <xs:simpleType>
      <xs:restriction base="xs:string">
        <xs:enumeration
          value="Microsoft.SqlServer.Dts.Tasks.ActiveXScriptTask.ActiveXScriptTask,
            Microsoft.SqlServer.ActiveXScriptTask, Version=10.0.0.0, Culture=neutral,
            PublicKeyToken=89845dcd8080cc91"/>
        <xs:enumeration value="STOCK:ActiveXScriptTask"/>
      </xs:restriction>
    </xs:simpleType>
  </xs:attribute>
  <xs:attribute name="ThreadHint" use="optional" type="xs:int"/>
</xs:complexType>

```

2.6.3.1.1 TaskExePropertyNameEnum Type

The **TaskExePropertynameEnum** type is used by the anonymous type declarations in the [Executable Task Types](#) section. This type is not referenced anywhere in the formal XSD.

The following is the XSD for the **TaskExePropertyNameEnum** type.

```
<xs:simpleType name="TaskExePropertyNameEnum">
  <xs:restriction base="DTS:AnyNonPackageExecutablePropertyNameEnum">
    <xs:enumeration value="Description"/>
    <xs:enumeration value="DTSID"/>
    <xs:enumeration value="CreationName"/>
    <xs:enumeration value="ObjectName"/>
    <xs:enumeration value="ForceExecValue"/>
    <xs:enumeration value="ExecValue"/>
    <xs:enumeration value="ForceExecutionResult"/>
    <xs:enumeration value="Disabled"/>
    <xs:enumeration value="FailPackageOnFailure"/>
    <xs:enumeration value="FailParentOnFailure"/>
    <xs:enumeration value="MaxErrorCount"/>
    <xs:enumeration value="ISOLevel"/>
    <xs:enumeration value="LocaleID"/>
    <xs:enumeration value="TransactionOption"/>
    <xs:enumeration value="DelayValidation"/>
    <xs:enumeration value="DisableEventHandlers"/>
    <xs:enumeration value="ExecutionLocation"/>
    <xs:enumeration value="ExecutionAddress"/>
    <xs:enumeration value="TaskContact"/>
    <xs:enumeration value="SqlStatementSource"/>
  </xs:restriction>
</xs:simpleType>
```

The interpretation of the values in the **TaskExePropertyNameEnum** type is given in [\[link??\]](#) AnyNonPackageExecutablePropertyNameEnum.

2.6.3.2 ExecutableType Instance for AS Execute DDL Task

Analysis Services (AS) Execute Data Definition Language (DDL) Task is a task that executes Analysis Services DDL language. AS DDL language is used to create, modify, and manage server objects on an Analysis Services server. An executable is an Analysis Services (AS) Execute Data Definition Language (DDL) Task executable if the **ExecutableType** attribute value is "Microsoft.DataTransformationServices.Tasks.DTSProcessingTask.ASExecutedDDLTask, Microsoft.SqlServer.ASTasks, Version=10.0.0.0, Culture=neutral, PublicKeyToken=89845dcd8080cc91".

The AS Execute DDL Task executable is formally defined to be of type [AnyNonPackageExecutableType](#). However, the following XSD fragment, which is expressed as an anonymous complex type declaration, places further restrictions on the type than the restrictions that are declared in the **AnyNonPackageExecutableType** type declaration. An [Executable](#) element with the **ExecutableType** attribute value equal to "Microsoft.DataTransformationServices.Tasks.DTSProcessingTask.ASExecutedDDLTask, Microsoft.SqlServer.ASTasks, Version=10.0.0.0, Culture=neutral, PublicKeyToken=89845dcd8080cc91" MUST follow the anonymous type declaration that is contained in this section.

Note the following differences between this anonymous complex type declaration and the full definition of the complex type for the **AnyNonPackageExecutableType** type:

- This **Executable** element MUST NOT contain an **Executable** element.
- This **Executable** element MUST NOT contain a **ForEachEnumerator** element.
- This **Executable** element MUST NOT contain a **ForEachVariableMapping** element.

- In the **AnyNonPackageExecutableType** type, the type of the **ObjectData** element is given as [ExecutableObjectDataType](#). The **ExecutableObjectDataType** type definition contains an **xs:choice** XSD Schema element. However, not all of the choices that are allowed in the **xs:choice** XSD Schema element are available for the AS Execute DDL executable. For this **Executable** element, the **ObjectData** element MUST contain the **ASDdlData** element of type [ASDdlDataObjectDataType](#).
- The allowed values for the **Name** attribute of the **Property** element are a restricted subset of the values that are allowed on the type, as specified in the **AnyNonPackageExecutablePropertyNameEnum** type. Hence, the formal type declaration of the **Property** element and the **PropertyExpression** elements are replaced in this anonymous XSD fragment with a reference to the [TaskExePropertyNameEnum](#) simple type. The **Name** attribute of the **Property** element MUST be restricted to the values that are shown as valid in the XSD fragment contained in that section.

For more information about the elements, attributes, and enumeration values in the following XSD fragment, see section 2.5.

```
<xs:complexType>
  <xs:sequence>
    <xs:element name="ForEachEnumerator"
      type="DTS:ForEachEnumeratorType"
      minOccurs="0" maxOccurs="0"/>
    <xs:element name="Property"
      maxOccurs="unbounded">
      <xs:complexType>
        <xs:complexContent>
          <xs:extension base="DTS:PropertyElementBaseType">
            <xs:attribute name="Name"
              type="DTS:TaskExePropertyNameEnum"
              use="required"/>
          </xs:extension>
        </xs:complexContent>
      </xs:complexType>
    </xs:element>
    <xs:element name="Variable" type="DTS:VariableType"
      minOccurs="0" maxOccurs="unbounded"/>
    <xs:element name="LoggingOptions" type="DTS:LoggingOptionsType" />
    <xs:element name="PropertyExpression"
      type="DTS:PropertyExpressionElementType"
      minOccurs="0" maxOccurs="unbounded"/>
    <xs:element name="PrecedenceConstraint"
      type="DTS:PrecedenceConstraintType"
      minOccurs="0" maxOccurs="unbounded"/>
    <xs:element name="ForEachVariableMapping"
      type="DTS:ForEachVariableMappingType"
      minOccurs="0" maxOccurs="0"/>
    <xs:element name="EventHandler" type="DTS:EventHandlerType"
      minOccurs="0" maxOccurs="unbounded"/>
    <xs:element name="ObjectData">
      <xs:complexType>
        <xs:choice>
          <xs:element name="ASDdlData" type="DTS:ASDdlDataObjectDataType"/>
        </xs:choice>
      </xs:complexType>
    </xs:element>
  </xs:sequence>
  <xs:attribute name="ExecutableType" use="required">
    <xs:simpleType>
      <xs:restriction base="xs:string">
        <xs:enumeration
          value="Microsoft.DataTransformationServices.Tasks.DTSProcessingTask.ASExecuteDDLTask,
            Microsoft.SqlServer.ASTasks, Version=10.0.0.0, Culture=neutral,
            PublicKeyToken=89845dcd8080cc91"/>
      </xs:restriction>
    </xs:simpleType>
  </xs:attribute>
</xs:complexType>
```

```

    </xs:attribute>
    <xs:attribute name="ThreadHint" use="optional" type="xs:int"/>
  </xs:complexType>

```

2.6.3.3 ExecutableType Instance for AS Processing Task

Analysis Services (AS) Processing Task is used to initiate the processing of Analysis Services objects by an Analysis Services server. An executable is an AS Processing Task executable if the **ExecutableType** attribute value is "Microsoft.DataTransformationServices.Tasks.DTSProcessingTask.DTSProcessingTask, Microsoft.SqlServer.ASTasks, Version=10.0.0.0, Culture=neutral, PublicKeyToken=89845dcd8080cc91".

The AS Processing Task executable is formally defined to be of type [AnyNonPackageExecutableType](#). However, the following XSD fragment, which is expressed as an anonymous complex type declaration, places further restrictions on the type than the restrictions that are declared in the **AnyNonPackageExecutableType** type declaration. An [Executable](#) element with the **ExecutableType** attribute value equal to "Microsoft.DataTransformationServices.Tasks.DTSProcessingTask.DTSProcessingTask, Microsoft.SqlServer.ASTasks, Version=10.0.0.0, Culture=neutral, PublicKeyToken=89845dcd8080cc91" MUST follow the anonymous type declaration that is contained in this section.

Note the following differences between this anonymous complex type declaration and the full definition of the complex type for the **AnyNonPackageExecutableType** type:

- This **Executable** element MUST NOT contain an **Executable** element.
- This **Executable** element MUST NOT contain a **ForEachEnumerator** element.
- This **Executable** element MUST NOT contain a **ForEachVariableMapping** element.
- In the **AnyNonPackageExecutableType** type, the type of the **ObjectData** element is given as [ExecutableObjectDataType](#). The **ExecutableObjectDataType** type definition contains an **xs:choice** XSD Schema element. However, not all of the choices that are allowed in the **xs:choice** XSD Schema element are available for the AS Processing Task executable. For this **Executable** element, the **ObjectData** element MUST contain the **ASProcessingData** element of type [ASProcessingDataObjectDataType](#).
- The allowed values for the **Name** attribute of the **Property** element are a restricted subset of those that are allowed on the type, as specified in the **AnyNonPackageExecutablePropertyNameEnum** type. Hence, the formal type declaration of the **Property** element and the **PropertyExpression** elements are replaced in this anonymous XSD fragment with a reference to the [TaskExePropertyNameEnum](#) simple type. The **Name** attribute of the **Property** element MUST be restricted to the values that are shown as valid in the XSD fragment that is contained in that section.

For more information about the elements, attributes, and enumeration values in the following XSD fragment, see section 2.5.

```

<xs:complexType>
  <xs:sequence>
    <xs:element name="ForEachEnumerator"
      type="DTS:ForEachEnumeratorType"
      minOccurs="0" maxOccurs="0"/>
    <xs:element name="Property"
      maxOccurs="unbounded">
      <xs:complexType>
        <xs:complexContent>

```

```

        <xs:extension base="DTS:PropertyElementBaseType">
            <xs:attribute name="Name"
                type="DTS:TaskExePropertyNameEnum"
                use="required"/>
        </xs:extension>
    </xs:complexContent>
</xs:complexType>
</xs:element>
<xs:element name="Variable" type="DTS:VariableType"
    minOccurs="0" maxOccurs="unbounded"/>
<xs:element name="LoggingOptions" type="DTS:LoggingOptionsType" />
<xs:element name="PropertyExpression"
    type="DTS:PropertyExpressionElementType"
    minOccurs="0" maxOccurs="unbounded"/>
<xs:element name="PrecedenceConstraint"
    type="DTS:PrecedenceConstraintType"
    minOccurs="0" maxOccurs="unbounded"/>
<xs:element name="ForEachVariableMapping"
    type="DTS:ForEachVariableMappingType"
    minOccurs="0" maxOccurs="0"/>
<xs:element name="EventHandler" type="DTS:EventHandlerType"
    minOccurs="0" maxOccurs="unbounded"/>
<xs:element name="ObjectData">
    <xs:complexType>
        <xs:choice>
            <xs:element name="ASProcessingData"
                type="DTS:ASProcessingDataObjectDataType"/>
        </xs:choice>
    </xs:complexType>
</xs:element>
</xs:sequence>
<xs:attribute name="ExecutableType" use="required">
    <xs:simpleType>
        <xs:restriction base="xs:string">
            <xs:enumeration
                value="Microsoft.DataTransformationServices.Tasks.DTSProcessingTask.DTSProcessingTask,
                Microsoft.SqlServer.ASTasks, Version=10.0.0.0, Culture=neutral,
                PublicKeyToken=89845dcd8080cc91"/>
        </xs:restriction>
    </xs:simpleType>
</xs:attribute>
<xs:attribute name="ThreadHint" use="optional" type="xs:int"/>
</xs:complexType>

```

2.6.3.4 ExecutableType Instance for Bulk Insert Task

Bulk Insert Task executes the Microsoft SQL Server bulk insert statement. An executable is a Bulk Insert Task executable if the **ExecutableType** attribute value is one of the following:

- Microsoft.SqlServer.Dts.Tasks.BulkInsertTask.BulkInsertTask, Microsoft.SqlServer.BulkInsertTask, Version=10.0.0.0, Culture=neutral, PublicKeyToken=89845dcd8080cc91
- STOCK:BulkInsertTask

The Bulk Insert Task executable is formally defined to be of type [AnyNonPackageExecutableType](#). However, the following XSD fragment, which is expressed as an anonymous complex type declaration, places further restrictions on the type than the restrictions that are declared in the **AnyNonPackageExecutableType** type declaration. An [Executable](#) element with the **ExecutableType** attribute value equal to "Microsoft.SqlServer.Dts.Tasks.BulkInsertTask.BulkInsertTask, Microsoft.SqlServer.BulkInsertTask, Version=10.0.0.0, Culture=neutral, PublicKeyToken=89845dcd8080cc91" or "STOCK:BulkInsertTask" MUST follow the anonymous type declaration that is contained in this section.

Note the following differences between this anonymous complex type declaration and the full definition of the complex type for the **AnyNonPackageExecutableType** type:

- This **Executable** element MUST NOT contain an **Executable** element.
- This **Executable** element MUST NOT contain a **ForEachEnumerator** element.
- This **Executable** element MUST NOT contain a **ForEachVariableMapping** element.
- In the **AnyNonPackageExecutableType** type, the type of the **ObjectData** element is given as [ExecutableObjectDataType](#). The **ExecutableObjectDataType** type definition contains an **xs:choice** XSD Schema element. However, not all of the choices that are allowed in the **xs:choice** XSD Schema element are available for the Bulk Insert Task executable. For this **Executable** element, the **ObjectData** element MUST contain the **BulkInsertTask:BulkInsertTaskData** element that is specified in the [BulkInsertTask](#) namespace.
- The allowed values for the **Name** attribute of the **Property** element are a restricted subset of the values that are allowed on the type, as specified in the **AnyNonPackageExecutablePropertyNameEnum** type. Hence, the formal type declarations of the **Property** element and the **PropertyExpression** elements are replaced in this anonymous XSD fragment with a reference to the [TaskExePropertyNameEnum](#) simple type. The **Name** attribute of the **Property** element MUST be restricted to the values that are shown as valid in the XSD fragment that is contained in this section.

For more information about the elements, attributes, and enumeration values in the following XSD fragment, see section 2.5.

```
<xs:complexType>
  <xs:sequence>
    <xs:element name="ForEachEnumerator"
      type="DTS:ForEachEnumeratorType"
      minOccurs="0" maxOccurs="0"/>
    <xs:element name="Property"
      maxOccurs="unbounded">
      <xs:complexType>
        <xs:complexContent>
          <xs:extension base="DTS:PropertyElementBaseType">
            <xs:attribute name="Name"
              type="DTS:TaskExePropertyNameEnum"
              use="required"/>
          </xs:extension>
        </xs:complexContent>
      </xs:complexType>
    </xs:element>
    <xs:element name="Variable" type="DTS:VariableType"
      minOccurs="0" maxOccurs="unbounded"/>
    <xs:element name="LoggingOptions" type="DTS:LoggingOptionsType"/>
    <xs:element name="PropertyExpression"
      type="DTS:PropertyExpressionElementType"
      minOccurs="0" maxOccurs="unbounded"/>
    <xs:element name="PrecedenceConstraint"
      type="DTS:PrecedenceConstraintType"
      minOccurs="0" maxOccurs="unbounded"/>
    <xs:element name="ForEachVariableMapping"
      type="DTS:ForEachVariableMappingType"
      minOccurs="0" maxOccurs="0"/>
    <xs:element name="EventHandler" type="DTS:EventHandlerType"
      minOccurs="0" maxOccurs="unbounded"/>
    <xs:element name="ObjectData">
      <xs:complexType>
        <xs:choice>
          <xs:element ref="BulkInsertTask:BulkInsertTaskData"/>
        </xs:choice>
      </xs:complexType>
    </xs:element>
  </xs:sequence>
</xs:complexType>
```



```

</xs:sequence>
<xs:attribute name="ExecutableType" use="required">
  <xs:simpleType>
    <xs:restriction base="xs:string">
      <xs:enumeration value="Microsoft.SqlServer.Dts.Tasks.BulkInsertTask.BulkInsertTask,
Microsoft.SqlServer.BulkInsertTask, Version=10.0.0.0, Culture=neutral,
PublicKeyToken=89845dcd8080cc91"/>
      <xs:enumeration value="STOCK:BulkInsertTask"/>
    </xs:restriction>
  </xs:simpleType>
</xs:attribute>
<xs:attribute name="ThreadHint" use="optional" type="xs:int"/>
</xs:complexType>

```

2.6.3.5 ExecutableType Instance for Data Mining Query Task

Data Mining Query Task runs data mining prediction queries based on data mining models that are built in Analysis Services. The prediction query creates a prediction for new data by using mining models. An executable is a Data Mining Query Task executable if the **ExecutableType** attribute value is "Microsoft.SqlServer.Dts.Tasks.DMQueryTask.DMQueryTask, Microsoft.SqlServer.DMQueryTask, Version=10.0.0.0, Culture=neutral, PublicKeyToken=89845dcd8080cc91".

The Data Mining Query Task executable is formally defined to be of type [AnyNonPackageExecutableType](#). However, the following XSD fragment, which is expressed as an anonymous complex type declaration, places further restrictions on the type than the restrictions that are declared in the **AnyNonPackageExecutableType** type declaration. An [Executable](#) element with the **ExecutableType** attribute value equal to "Microsoft.SqlServer.Dts.Tasks.DMQueryTask.DMQueryTask, Microsoft.SqlServer.DMQueryTask, Version=10.0.0.0, Culture=neutral, PublicKeyToken=89845dcd8080cc91" MUST follow the anonymous type declaration that is contained in this section.

Note the following differences between this anonymous complex type declaration and the full definition of the complex type for the **AnyNonPackageExecutableType** type:

- This **Executable** element MUST NOT contain an **Executable** element.
- This **Executable** element MUST NOT contain a **ForEachEnumerator** element.
- This **Executable** element MUST NOT contain a **ForEachVariableMapping** element.
- In the **AnyNonPackageExecutableType** type, the type of the **ObjectData** element is given as [ExecutableObjectDataType](#). The **ExecutableObjectDataType** type definition contains an **xs:choice** XSD Schema element. However, not all of the choices that are allowed in the **xs:choice** XSD Schema element are available for the Data Mining Query Task executable. For this **Executable** element, the **ObjectData** element MUST contain the **DMQuertTaskData** element of type [DMQueryTaskDataObjectDataType](#).
- The allowed values for the **Name** attribute of the **Property** element are a restricted subset of the values that are allowed on the type, as specified in the **AnyNonPackageExecutablePropertyNameEnum** type. Hence, the formal type declarations of the **Property** element and the **PropertyExpression** elements are replaced in this anonymous XSD fragment with a reference to the [TaskExePropertyNameEnum](#) simple type. The **Name** attribute of the **Property** element MUST be restricted to the values that are shown as valid in the XSD fragment that is contained in that section.

For more information about the elements, attributes, and enumeration values in the following XSD fragment, see section 2.5.

```

<xs:complexType>
  <xs:sequence>

```



```

<xs:element name="ForEachEnumerator"
  type="DTS:ForEachEnumeratorType"
  minOccurs="0" maxOccurs="0"/>
<xs:element name="Property"
  maxOccurs="unbounded">
  <xs:complexType>
    <xs:complexContent>
      <xs:extension base="DTS:PropertyElementBaseType">
        <xs:attribute name="Name"
          type="DTS:TaskExePropertyNameEnum"
          use="required"/>
      </xs:extension>
    </xs:complexContent>
  </xs:complexType>
</xs:element>
<xs:element name="Variable" type="DTS:VariableType"
  minOccurs="0" maxOccurs="unbounded"/>
<xs:element name="LoggingOptions" type="DTS:LoggingOptionsType"/>
<xs:element name="PropertyExpression"
  type="DTS:PropertyExpressionElementType"
  minOccurs="0" maxOccurs="unbounded"/>
<xs:element name="PrecedenceConstraint"
  type="DTS:PrecedenceConstraintType"
  minOccurs="0" maxOccurs="unbounded"/>
<xs:element name="ForEachVariableMapping"
  type="DTS:ForEachVariableMappingType"
  minOccurs="0" maxOccurs="0"/>
<xs:element name="EventHandler" type="DTS:EventHandlerType"
  minOccurs="0" maxOccurs="unbounded"/>
<xs:element name="ObjectData">
  <xs:complexType>
    <xs:choice>
      <xs:element name="DMQuertTaskData" form="unqualified"
        type="DTS:DMQueryTaskDataObjectType"/>
    </xs:choice>
  </xs:complexType>
</xs:element>
</xs:sequence>
<xs:attribute name="ExecutableType" use="required">
  <xs:simpleType>
    <xs:restriction base="xs:string">
      <xs:enumeration
        value="Microsoft.SqlServer.Dts.Tasks.DMQueryTask.DMQueryTask,
Microsoft.SqlServer.DMQueryTask, Version=10.0.0.0, Culture=neutral,
PublicKeyToken=89845dcd8080cc91"/>
    </xs:restriction>
  </xs:simpleType>
</xs:attribute>
<xs:attribute name="ThreadHint" use="optional" type="xs:int"/>
</xs:complexType>

```

2.6.3.6 ExecutableType Instance for Data Profiling Task

Data Profiling Task computes profiles of data that helps the user understand the values that are present in data and their distribution. An executable is a Data Profiling Task executable if the **ExecutableType** attribute value is

```
"Microsoft.SqlServer.Dts.Tasks.DataProfilingTask.DataProfilingTask,
Microsoft.SqlServer.DataProfilingTask, Version=10.0.0.0, Culture=neutral,
PublicKeyToken=89845dcd8080cc91".
```

The Data Profiling Task executable is formally defined to be of type [AnyNonPackageExecutableType](#). However, the following XSD fragment, which is expressed as an anonymous complex type declaration, places further restrictions on the type than the restrictions that are declared in the **AnyNonPackageExecutableType** type declaration. An [Executable](#) element with the **ExecutableType** attribute value equal to

"Microsoft.SqlServer.Dts.Tasks.DataProfilingTask.DataProfilingTask, Microsoft.SqlServer.DataProfilingTask, Version=10.0.0.0, Culture=neutral, PublicKeyToken=89845dcd8080cc91" MUST follow the anonymous type declaration that is contained in this section.

Note the following differences between this anonymous complex type declaration and the full definition of the complex type for the **AnyNonPackageExecutableType** type:

- This **Executable** element MUST NOT contain an **Executable** element.
- This **Executable** element MUST NOT contain a **ForEachEnumerator** element.
- This **Executable** element MUST NOT contain a **ForEachVariableMapping** element.
- In the **AnyNonPackageExecutableType** type, the type of the **ObjectData** element is given as [ExecutableObjectDataType](#). The **ExecutableObjectDataType** type definition contains an **xs:choice** XSD Schema element. However, not all of the choices that are allowed in the **xs:choice** XSD Schema element are available for the Data Profiling Task executable. For this **Executable** element, the **ObjectData** element MUST contain the **DataProfilingTaskData** element of type [DataProfilingTaskDataObjectDataType](#).
- The allowed values for the **Name** attribute of the **Property** element are a restricted subset of the values that are allowed on the type, as specified in the **AnyNonPackageExecutablePropertyNameEnum** type. Hence, the formal type declarations of the **Property** element and the **PropertyExpression** elements are replaced in this anonymous XSD fragment with a reference to the [TaskExePropertyNameEnum](#) simple type. The **Name** attribute of the **Property** element MUST be restricted to the values that are shown as valid in the XSD fragment that is contained in the **TaskExePropertyNameEnum** section.

For more information about the elements, attributes, and enumeration values in the following XSD fragment, see section 2.5.

```
<xs:complexType>
  <xs:sequence>
    <xs:element name="ForEachEnumerator"
      type="DTS:ForEachEnumeratorType"
      minOccurs="0" maxOccurs="0"/>
    <xs:element name="Property"
      maxOccurs="unbounded">
      <xs:complexType>
        <xs:complexContent>
          <xs:extension base="DTS:PropertyElementBaseType">
            <xs:attribute name="Name"
              type="DTS:TaskExePropertyNameEnum"
              use="required"/>
          </xs:extension>
        </xs:complexContent>
      </xs:complexType>
    </xs:element>
    <xs:element name="Variable" type="DTS:VariableType"
      minOccurs="0" maxOccurs="unbounded"/>
    <xs:element name="LoggingOptions" type="DTS:LoggingOptionsType"/>
    <xs:element name="PropertyExpression"
      type="DTS:PropertyExpressionElementType"
      minOccurs="0" maxOccurs="unbounded"/>
    <xs:element name="PrecedenceConstraint"
      type="DTS:PrecedenceConstraintType"
      minOccurs="0" maxOccurs="unbounded"/>
    <xs:element name="ForEachVariableMapping"
      type="DTS:ForEachVariableMappingType"
      minOccurs="0" maxOccurs="0"/>
    <xs:element name="EventHandler" type="DTS:EventHandlerType"
      minOccurs="0" maxOccurs="unbounded"/>
    <xs:element name="ObjectData">
```

```

    <xs:complexType>
      <xs:choice>
        <xs:element name="DataProfilingTaskData" form="unqualified"
          type="DTS:DataProfilingTaskDataObjectDataType"/>
      </xs:choice>
    </xs:complexType>
  </xs:element>
</xs:sequence>
<xs:attribute name="ExecutableType" use="required">
  <xs:simpleType>
    <xs:restriction base="xs:string">
      <xs:enumeration
value="Microsoft.SqlServer.Dts.Tasks.DataProfilingTask.DataProfilingTask,
Microsoft.SqlServer.DataProfilingTask, Version=10.0.0.0, Culture=neutral,
PublicKeyToken=89845dcd8080cc91"/>
    </xs:restriction>
  </xs:simpleType>
</xs:attribute>
<xs:attribute name="ThreadHint" use="optional" type="xs:int"/>
</xs:complexType>

```

2.6.3.7 ExecutableType Instance for Execute DTS 2000 Package Task

Data Transformation Services (DTS) 2000 Package is a package file in the format of Microsoft SQL Server 2000. DTS 2000 Package can execute such packages in Microsoft SQL Server Integration Services (SSIS). Execute DTS 2000 Package Task executes a package from SQL Server 2000.

An executable is an Execute DTS 2000 Package Task executable if the **ExecutableType** attribute value is one off the following:

- Microsoft.SqlServer.Dts.Tasks.Exec80PackageTask.Exec80PackageTask, Microsoft.SqlServer.Exec80PackageTask, Version=10.0.0.0, Culture=neutral, PublicKeyToken=89845dcd8080cc91
- STOCK:Exec80PackageTask

The Execute DTS 2000 Package Task executable is formally defined to be of type [AnyNonPackageExecutableType](#). However, the following XSD fragment, which is expressed as an anonymous complex type declaration, places further restrictions on the type than the restrictions that are declared in the **AnyNonPackageExecutableType** type declaration. An [Executable](#) element with the **ExecutableType** attribute value equal to "Microsoft.SqlServer.Dts.Tasks.Exec80PackageTask.Exec80PackageTask, Microsoft.SqlServer.Exec80PackageTask, Version=10.0.0.0, Culture=neutral, PublicKeyToken=89845dcd8080cc91" or "STOCK:Exec80PackageTask" MUST follow the anonymous type declaration that is contained in this section.

Note the following differences between this anonymous complex type declaration and the full definition of the complex type for the **AnyNonPackageExecutableType** type:

- This **Executable** element MUST NOT contain an **Executable** element.
- This **Executable** element MUST NOT contain a **ForEachEnumerator** element.
- This **Executable** element MUST NOT contain a **ForEachVariableMapping** element.
- In the **AnyNonPackageExecutableType** type, the type of the **ObjectData** element is given as [ExecutableObjectDataType](#). The **ExecutableObjectDataType** type definition contains an **xs:choice** XSD Schema element. However, not all of the choices that are allowed in the **xs:choice** XSD Schema element are available for the Execute DTS 2000 Package Task executable. For this **Executable** element, the **ObjectData** element MUST contain the [Exec80PackageTaskData](#) element that is specified in the [Exec80PackageTask](#) namespace.

- The allowed values for the **Name** attribute of the **Property** element are a restricted subset of the values that are allowed on the type, as specified in the **AnyNonPackageExecutablePropertyNameEnum** type. Hence, the formal type declarations of the **Property** element and the **PropertyExpression** elements are replaced in this anonymous XSD fragment with a reference to the [TaskExePropertyNameEnum](#) simple type. The **Name** attribute of the **Property** element MUST be restricted to the values that are shown as valid in the XSD fragment that is contained in the **TaskExePropertyNameEnum** section.

For more information about the elements, attributes, and enumeration values in the following XSD fragment, see section 2.5.

```

<xs:complexType>
  <xs:sequence>
    <xs:element name="ForEachEnumerator"
      type="DTS:ForEachEnumeratorType"
      minOccurs="0" maxOccurs="0"/>
    <xs:element name="Property"
      maxOccurs="unbounded">
      <xs:complexType>
        <xs:complexContent>
          <xs:extension base="DTS:PropertyElementBaseType">
            <xs:attribute name="Name"
              type="DTS:TaskExePropertyNameEnum"
              use="required"/>
          </xs:extension>
        </xs:complexContent>
      </xs:complexType>
    </xs:element>
    <xs:element name="Variable" type="DTS:VariableType"
      minOccurs="0" maxOccurs="unbounded"/>
    <xs:element name="LoggingOptions" type="DTS:LoggingOptionsType"/>
    <xs:element name="PropertyExpression"
      type="DTS:PropertyExpressionElementType"
      minOccurs="0" maxOccurs="unbounded"/>
    <xs:element name="PrecedenceConstraint"
      type="DTS:PrecedenceConstraintType"
      minOccurs="0" maxOccurs="unbounded"/>
    <xs:element name="ForEachVariableMapping"
      type="DTS:ForEachVariableMappingType"
      minOccurs="0" maxOccurs="0"/>
    <xs:element name="EventHandler" type="DTS:EventHandlerType"
      minOccurs="0" maxOccurs="unbounded"/>
    <xs:element name="ObjectData">
      <xs:complexType>
        <xs:choice>
          <xs:element ref="Exec80PackageTask:Exec80PackageTaskData"/>
        </xs:choice>
      </xs:complexType>
    </xs:element>
  </xs:sequence>
  <xs:attribute name="ExecutableType" use="required">
    <xs:simpleType>
      <xs:restriction base="xs:string">
        <xs:enumeration
          value="Microsoft.SqlServer.Dts.Tasks.Exec80PackageTask.Exec80PackageTask,
Microsoft.SqlServer.Exec80PackageTask, Version=10.0.0.0, Culture=neutral,
PublicKeyToken=89845dcd8080cc91"/>
        <xs:enumeration value="STOCK:Exec80PackageTask"/>
      </xs:restriction>
    </xs:simpleType>
  </xs:attribute>
  <xs:attribute name="ThreadHint" use="optional" type="xs:int"/>
</xs:complexType>

```

2.6.3.8 ExecutableType Instance for Execute Package Task

Execute Package Task executes a package that is stored independently, such as in a file or in a database, of the package that is currently executing. An executable is an Execute Package Task executable if the **ExecutableType** attribute value is one of the following:

- SSIS.ExecutePackageTask.2
- STOCK:ExecutePackageTask

The Execute Package Task executable is formally defined to be of type [AnyNonPackageExecutableType](#). However, the following XSD fragment, which is expressed as an anonymous complex type declaration, places further restrictions on the type than the restrictions that are declared in the **AnyNonPackageExecutableType** type declaration. An [Executable](#) element with the **ExecutableType** attribute value equal to "SSIS.ExecutePackageTask.2" or "STOCK:ExecutePackageTask" MUST follow the anonymous type declaration that is contained in this section.

Note the following differences between this anonymous complex type declaration and the full definition of the complex type for the **AnyNonPackageExecutableType** type:

- This **Executable** element MUST NOT contain an **Executable** element.
- This **Executable** element MUST NOT contain a **ForEachEnumerator** element.
- This **Executable** element MUST NOT contain a **ForEachVariableMapping** element.
- In the **AnyNonPackageExecutableType** type, the type of the **ObjectData** element is given as [ExecutableObjectDataType](#). The **ExecutableObjectDataType** type definition contains an **xs:choice** XSD Schema element. However, not all of the choices that are allowed in the **xs:choice** XSD Schema element are available for the Execute Package Task executable. For this **Executable** element, the **ObjectData** element MUST contain the **ExecutePackageTask** element of type [ExecutePackageTaskObjectDataType](#).
- The allowed values for the **Name** attribute of the **Property** element are a restricted subset of the values that are allowed on the type, as specified in the **AnyNonPackageExecutablePropertyNameEnum** type. Hence, the formal type declarations of the **Property** element and the **PropertyExpression** elements are replaced in this anonymous XSD fragment with a reference to the [TaskExePropertyNameEnum](#) simple type. The **Name** attribute of the **Property** element MUST be restricted to the values that are shown as valid in the XSD fragment that is contained in the **TaskExePropertyNameEnum** section.

For more information about the elements, attributes, and enumeration values in the following XSD fragment, see section 2.5.

```
<xs:complexType>
  <xs:sequence>
    <xs:element name="ForEachEnumerator"
      type="DTS:ForEachEnumeratorType"
      minOccurs="0" maxOccurs="0"/>
    <xs:element name="Property"
      maxOccurs="unbounded">
      <xs:complexType>
        <xs:complexContent>
          <xs:extension base="DTS:PropertyElementBaseType">
            <xs:attribute name="Name"
              type="DTS:TaskExePropertyNameEnum"
              use="required"/>
          </xs:extension>
        </xs:complexContent>
      </xs:complexType>
    </xs:element>
```

```

<xs:element name="Variable" type="DTS:VariableType"
  minOccurs="0" maxOccurs="unbounded"/>
<xs:element name="LoggingOptions" type="DTS:LoggingOptionsType"/>
<xs:element name="PropertyExpression"
  type="DTS:PropertyExpressionElementType"
  minOccurs="0" maxOccurs="unbounded"/>
<xs:element name="PrecedenceConstraint"
  type="DTS:PrecedenceConstraintType"
  minOccurs="0" maxOccurs="unbounded"/>
<xs:element name="ForEachVariableMapping"
  type="DTS:ForEachVariableMappingType"
  minOccurs="0" maxOccurs="0"/>
<xs:element name="EventHandler" type="DTS:EventHandlerType"
  minOccurs="0" maxOccurs="unbounded"/>
<xs:element name="ObjectData">
  <xs:complexType>
    <xs:choice>
      <xs:element name="ExecutePackageTask" form="unqualified"
        type="DTS:ExecutePackageTaskObjectDataType"/>
    </xs:choice>
  </xs:complexType>
</xs:element>
</xs:sequence>
<xs:attribute name="ExecutableType" use="required">
  <xs:simpleType>
    <xs:restriction base="xs:string">
      <xs:enumeration
        value="SSIS.ExecutePackageTask.2"/>
      <xs:enumeration value="STOCK:ExecutePackageTask"/>
    </xs:restriction>
  </xs:simpleType>
</xs:attribute>
<xs:attribute name="ThreadHint" use="optional" type="xs:int"/>
</xs:complexType>

```

2.6.3.9 ExecutableType Instance for Execute Process Task

Execute Process Task runs an application or batch file as part of a package workflow. An executable is an Execute Process Task executable if the **ExecutableType** attribute value is one of the following:

- Microsoft.SqlServer.Dts.Tasks.ExecuteProcess.ExecuteProcess, Microsoft.SqlServer.ExecProcTask, Version=10.0.0.0, Culture=neutral, PublicKeyToken=89845dcd8080cc91
- STOCK:ExecuteProcessTask

The Execute Process Task executable is formally defined to be of type [AnyNonPackageExecutableType](#). However, the following XSD fragment, which is expressed as an anonymous complex type declaration, places further restrictions on the type than the restrictions that are declared in the **AnyNonPackageExecutableType** type declaration. An [Executable](#) element with the **ExecutableType** attribute value equal to "Microsoft.SqlServer.Dts.Tasks.ExecuteProcess.ExecuteProcess, Microsoft.SqlServer.ExecProcTask, Version=10.0.0.0, Culture=neutral, PublicKeyToken=89845dcd8080cc91" or "STOCK:ExecuteProcessTask" MUST follow the anonymous type declaration that is contained in this section.

Note the following differences between this anonymous complex type declaration and the full definition of the complex type for the **AnyNonPackageExecutableType** type:

- This **Executable** element MUST NOT contain an **Executable** element.
- This **Executable** element MUST NOT contain a **ForEachEnumerator** element.
- This **Executable** element MUST NOT contain a **ForEachVariableMapping** element.

- In the **AnyNonPackageExecutableType** type, the type of the **ObjectData** element is given as [ExecutableObjectDataType](#). The **ExecutableObjectDataType** type definition contains an **xs:choice** XSD Schema element. However, not all of the choices that are allowed in the **xs:choice** XSD Schema element are available for the Execute Process Task executable. For this **Executable** element, the **ObjectData** element MUST contain the **ExecuteProcessData** element of type [ExecuteProcessDataObjectDataType](#).
- The allowed values for the **Name** attribute of the **Property** element are a restricted subset of the values that are allowed on the type, as specified in the **AnyNonPackageExecutablePropertyNameEnum** type. Hence, the formal type declarations of the **Property** element and the **PropertyExpression** elements are replaced in this anonymous XSD fragment with a reference to the [TaskExePropertyNameEnum](#) simple type. The **Name** attribute of the **Property** element MUST be restricted to the values that are shown as valid in the XSD fragment that is contained in the **TaskExePropertyNameEnum** section.

For more information about the elements, attributes, and enumeration values in the following XSD fragment, see section 2.5.

```

<xs:complexType>
  <xs:sequence>
    <xs:element name="ForEachEnumerator"
      type="DTS:ForEachEnumeratorType"
      minOccurs="0" maxOccurs="0"/>
    <xs:element name="Property"
      maxOccurs="unbounded">
      <xs:complexType>
        <xs:complexContent>
          <xs:extension base="DTS:PropertyElementBaseType">
            <xs:attribute name="Name"
              type="DTS:TaskExePropertyNameEnum"
              use="required"/>
          </xs:extension>
        </xs:complexContent>
      </xs:complexType>
    </xs:element>
    <xs:element name="Variable" type="DTS:VariableType"
      minOccurs="0" maxOccurs="unbounded"/>
    <xs:element name="LoggingOptions" type="DTS:LoggingOptionsType"/>
    <xs:element name="PropertyExpression"
      type="DTS:PropertyExpressionElementType"
      minOccurs="0" maxOccurs="unbounded"/>
    <xs:element name="PrecedenceConstraint"
      type="DTS:PrecedenceConstraintType"
      minOccurs="0" maxOccurs="unbounded"/>
    <xs:element name="ForEachVariableMapping"
      type="DTS:ForEachVariableMappingType"
      minOccurs="0" maxOccurs="0"/>
    <xs:element name="EventHandler" type="DTS:EventHandlerType"
      minOccurs="0" maxOccurs="unbounded"/>
    <xs:element name="ObjectData">
      <xs:complexType>
        <xs:choice>
          <xs:element name="ExecuteProcessData" form="unqualified"
            type="DTS:ExecuteProcessDataObjectDataType"/>
        </xs:choice>
      </xs:complexType>
    </xs:element>
  </xs:sequence>
  <xs:attribute name="ExecutableType" use="required">
    <xs:simpleType>
      <xs:restriction base="xs:string">
        <xs:enumeration
          value="Microsoft.SqlServer.Dts.Tasks.ExecuteProcess.ExecuteProcess,
Microsoft.SqlServer.ExecProcTask, Version=10.0.0.0, Culture=neutral,
PublicKeyToken=89845dcd8080cc91"/>
        <xs:enumeration value="STOCK:ExecuteProcessTask"/>
      </xs:restriction>
    </xs:simpleType>
  </xs:attribute>

```



```

    </xs:restriction>
  </xs:simpleType>
</xs:attribute>
<xs:attribute name="ThreadHint" use="optional" type="xs:int"/>
</xs:complexType>

```

2.6.3.10 ExecutableType Instance for Execute SQL Task

Execute SQL Task runs SQL statements or stored procedures from a package. An executable is an Execute SQL Task executable if the **ExecutableType** attribute value is one of the following:

- Microsoft.SqlServer.Dts.Tasks.ExecuteSQLTask.ExecuteSQLTask, Microsoft.SqlServer.SQLTask, Version=10.0.0.0, Culture=neutral, PublicKeyToken=89845dcd8080cc91
- STOCK:SQLTask

The Execute SQL Task executable is formally defined to be of type [AnyNonPackageExecutableType](#). However, the following XSD fragment, which is expressed as an anonymous complex type declaration, places further restrictions on the type than the restrictions that are declared in the **AnyNonPackageExecutableType** type declaration.

An [Executable](#) element with the **ExecutableType** attribute value equal to "Microsoft.SqlServer.Dts.Tasks.ExecuteSQLTask.ExecuteSQLTask, Microsoft.SqlServer.SQLTask, Version=10.0.0.0, Culture=neutral, PublicKeyToken=89845dcd8080cc91" or "STOCK:SQLTask" MUST follow the anonymous type declaration that is contained in this section.

Note the following differences between this anonymous complex type declaration and the full definition of the complex type for the **AnyNonPackageExecutableType** type:

- This **Executable** element MUST NOT contain an **Executable** element.
- This **Executable** element MUST NOT contain a **ForEachEnumerator** element.
- This **Executable** element MUST NOT contain a **ForEachVariableMapping** element.
- In the **AnyNonPackageExecutableType** type, the type of the **ObjectData** element is given as [ExecutableObjectDataType](#). The **ExecutableObjectDataType** type definition contains an **xs:choice** XSD Schema element. However, not all of the choices that are allowed in the **xs:choice** XSD Schema element are available for the Execute SQL Task executable. For this **Executable** element, the **ObjectData** element MUST contain the [SqlTaskData](#) element that is specified in the [SQLTask](#) namespace. The **SqlTaskData** element declaration in the **SQLTask** namespace MUST be replaced by the declaration and type that is specified in this section. This instance of the **SqlTaskData** element MUST contain zero elements and MUST NOT contain attributes other than those that are specified in the [SqlTaskBaseAttributeGroup](#) attribute group.
- The allowed values for the **Name** attribute of the **Property** element are a restricted subset of the values that are allowed on the type, as specified in the **AnyNonPackageExecutablePropertyNameEnum** type. Hence, the formal type declarations of the **Property** element and the **PropertyExpression** elements are replaced in this anonymous XSD fragment with a reference to the [TaskExePropertyNameEnum](#) simple type. The **Name** attribute of the **Property** element MUST be restricted to the values that are shown as valid in the XSD fragment that is contained in the **TaskExePropertyNameEnum** section.

For more information about the elements, attributes, and enumeration values in the following XSD fragment, see section 2.5.

```

<xs:complexType>
  <xs:sequence>
    <xs:element name="ForEachEnumerator"

```



```

        type="DTS:ForEachEnumeratorType"
        minOccurs="0" maxOccurs="0"/>
<xs:element name="Property"
    maxOccurs="unbounded">
    <xs:complexType>
        <xs:complexContent>
            <xs:extension base="DTS:PropertyElementBaseType">
                <xs:attribute name="Name"
                    type="DTS:TaskExePropertyNameEnum"
                    use="required"/>
            </xs:extension>
        </xs:complexContent>
    </xs:complexType>
</xs:element>
<xs:element name="Variable" type="DTS:VariableType"
    minOccurs="0" maxOccurs="unbounded"/>
<xs:element name="LoggingOptions" type="DTS:LoggingOptionsType"/>
<xs:element name="PropertyExpression"
    type="DTS:PropertyExpressionElementType"
    minOccurs="0" maxOccurs="unbounded"/>
<xs:element name="PrecedenceConstraint"
    type="DTS:PrecedenceConstraintType"
    minOccurs="0" maxOccurs="unbounded"/>
<xs:element name="ForEachVariableMapping"
    type="DTS:ForEachVariableMappingType"
    minOccurs="0" maxOccurs="0"/>
<xs:element name="EventHandler" type="DTS:EventHandlerType"
    minOccurs="0" maxOccurs="unbounded"/>
<xs:element name="ObjectData">
    <xs:complexType>
        <xs:choice>
            <xs:element ref="SQLTask:SqlTaskData"/>
        </xs:choice>
    </xs:complexType>
</xs:sequence>
<xs:attribute name="ExecutableType" use="required">
    <xs:simpleType>
        <xs:restriction base="xs:string">
            <xs:enumeration
                value="Microsoft.SqlServer.Dts.Tasks.ExecuteSQLTask.ExecuteSQLTask,
Microsoft.SqlServer.SQLTask, Version=10.0.0.0, Culture=neutral,
PublicKeyToken=89845dcd8080cc91"/>
            <xs:enumeration value="STOCK:SQLTask"/>
        </xs:restriction>
    </xs:simpleType>
</xs:attribute>
<xs:attribute name="ThreadHint" use="optional" type="xs:int"/>
</xs:complexType>

```

The preceding anonymous complex type definition requires that the declaration for the **SqlTaskData** element and its type, in the **SQLTask** namespace, be changed to the following.

```

<xs:element name="SqlTaskData"
    type="SQLTask:SqlTaskDataElementSqlTaskType"/>
<xs:complexType name="SqlTaskDataElementSqlTaskType">
    <xs:sequence/>
    <xs:attributeGroup
        ref="SQLTask:SqlTaskBaseAttributeGroup"/>
</xs:complexType>

```

2.6.3.11 ExecutableType Instance for File System Task

File System Task performs operations on files and directories in the file system. An executable is a File System Task executable if the **ExecutableType** attribute value is one of the following:

- Microsoft.SqlServer.Dts.Tasks.FileSystemTask.FileSystemTask, Microsoft.SqlServer.FileSystemTask, Version=10.0.0.0, Culture=neutral, PublicKeyToken=89845dcd8080cc91
- STOCK:FileSystemTask

The File System Task executable is formally defined to be of type [AnyNonPackageExecutableType](#). However, the following XSD fragment, which is expressed as an anonymous complex type declaration, places further restrictions on the type than the restrictions that are declared in the **AnyNonPackageExecutableType** type declaration. An [Executable](#) element with the **ExecutableType** attribute value equal to "Microsoft.SqlServer.Dts.Tasks.FileSystemTask.FileSystemTask, Microsoft.SqlServer.FileSystemTask, Version=10.0.0.0, Culture=neutral, PublicKeyToken=89845dcd8080cc91" or "STOCK:FileSystemTask" MUST follow the anonymous type declaration that is contained in this section.

Note the following differences between this anonymous complex type declaration and the full definition of the complex type for the **AnyNonPackageExecutableType** type:

- This **Executable** element MUST NOT contain an **Executable** element.
- This **Executable** element MUST NOT contain a **ForEachEnumerator** element.
- This **Executable** element MUST NOT contain a **ForEachVariableMapping** element.
- In the **AnyNonPackageExecutableType** type, the type of the **ObjectData** element is given as [ExecutableObjectDataType](#). The **ExecutableObjectDataType** type definition contains an **xs:choice** XSD Schema element. However, not all of the choices that are allowed in the **xs:choice** XSD Schema element are available for the File System Task executable. For this **Executable** element, the **ObjectData** element MUST contain the **FileSystemData** element of type [FileSystemDataObjectDataType](#).
- The allowed values for the **Name** attribute of the **Property** element are a restricted subset of the values that are allowed on the type, as specified in the **AnyNonPackageExecutablePropertyNameEnum** type. Hence, the formal type declarations of the **Property** element and the **PropertyExpression** elements are replaced in this anonymous XSD fragment with a reference to the [TaskExePropertyNameEnum](#) simple type. The **Name** attribute of the **Property** element MUST be restricted to the values that are shown as valid in the XSD fragment that is contained in the **TaskExePropertyNameEnum** section.

For more information about the elements, attributes, and enumeration values in the following XSD fragment, see section 2.5.

```
<xs:complexType>
  <xs:sequence>
    <xs:element name="ForEachEnumerator"
      type="DTS:ForEachEnumeratorType"
      minOccurs="0" maxOccurs="0"/>
    <xs:element name="Property"
      maxOccurs="unbounded">
      <xs:complexType>
        <xs:complexContent>
          <xs:extension base="DTS:PropertyElementBaseType">
            <xs:attribute name="Name"
              type="DTS:TaskExePropertyNameEnum"
              use="required"/>
          </xs:extension>
        </xs:complexContent>
      </xs:complexType>
    </xs:element>
  </xs:sequence>
</xs:complexType>
```

```

    </xs:complexType>
  </xs:element>
  <xs:element name="Variable" type="DTS:VariableType"
    minOccurs="0" maxOccurs="unbounded"/>
  <xs:element name="LoggingOptions" type="DTS:LoggingOptionsType"/>
  <xs:element name="PropertyExpression"
    type="DTS:PropertyExpressionElementType"
    minOccurs="0" maxOccurs="unbounded"/>
  <xs:element name="PrecedenceConstraint"
    type="DTS:PrecedenceConstraintType"
    minOccurs="0" maxOccurs="unbounded"/>
  <xs:element name="ForEachVariableMapping"
    type="DTS:ForEachVariableMappingType"
    minOccurs="0" maxOccurs="0"/>
  <xs:element name="EventHandler" type="DTS:EventHandlerType"
    minOccurs="0" maxOccurs="unbounded"/>
  <xs:element name="ObjectData">
    <xs:complexType>
      <xs:choice>
        <xs:element name="FileSystemData" form="unqualified"
          type="DTS:FileSystemDataObjectDataType"/>
      </xs:choice>
    </xs:complexType>
  </xs:element>
</xs:sequence>
<xs:attribute name="ExecutableType" use="required">
  <xs:simpleType>
    <xs:restriction base="xs:string">
      <xs:enumeration
        value="Microsoft.SqlServer.Dts.Tasks.FileSystemTask.FileSystemTask,
Microsoft.SqlServer.FileSystemTask, Version=10.0.0.0, Culture=neutral,
PublicKeyToken=89845dcd8080cc91"/>
      <xs:enumeration value="STOCK:FileSystemTask"/>
    </xs:restriction>
  </xs:simpleType>
</xs:attribute>
<xs:attribute name="ThreadHint" use="optional" type="xs:int"/>
</xs:complexType>

```

2.6.3.12 ExecutableType Instance for FTP Task

FTP Task uses FTP calls to access, download, upload, and manage files on remote servers. An executable is an FTP Task executable if the **ExecutableType** attribute value is one of the following:

- Microsoft.SqlServer.Dts.Tasks.FtpTask.FtpTask, Microsoft.SqlServer.FtpTask, Version=10.0.0.0, Culture=neutral, PublicKeyToken=89845dcd8080cc91
- STOCK:FTPTask

The FTP Task executable is formally defined to be of type [AnyNonPackageExecutableType](#). However, the following XSD fragment, which is expressed as an anonymous complex type declaration, places further restrictions on the type than the restrictions that are declared in the **AnyNonPackageExecutableType** type declaration. An [Executable](#) element with the **ExecutableType** attribute value equal to "Microsoft.SqlServer.Dts.Tasks.FtpTask.FtpTask, Microsoft.SqlServer.FtpTask, Version=10.0.0.0, Culture=neutral, PublicKeyToken=89845dcd8080cc91" or "STOCK:FTPTask" MUST follow the anonymous type declaration that is contained in this section.

Note the following differences between this anonymous complex type declaration and the full definition of the complex type for the **AnyNonPackageExecutableType** type:

- This **Executable** element MUST NOT contain an **Executable** element.
- This **Executable** element MUST NOT contain a **ForEachEnumerator** element.

- This **Executable** element MUST NOT contain a **ForEachVariableMapping** element.
- In the **AnyNonPackageExecutableType** type, the type of the **ObjectData** element is given as [ExecutableObjectDataType](#). The **ExecutableObjectDataType** type definition contains an **xs:choice** XSD Schema element. However, not all of the choices that are allowed in the **xs:choice** XSD Schema element are available for the FTP Task executable. For this **Executable** element, the **ObjectData** element MUST contain the **FtpData** element of type [FtpDataObjectDataType](#).
- The allowed values for the **Name** attribute of the **Property** element are a restricted subset of the values that are allowed on the type, as specified in the **AnyNonPackageExecutablePropertyNameEnum** type. Hence, the formal type declarations of the **Property** element and the **PropertyExpression** elements are replaced in this anonymous XSD fragment with a reference to the [TaskExePropertyNameEnum](#) simple type. The **Name** attribute of the **Property** element MUST be restricted to the values that are shown as valid in the XSD fragment that is contained in the **TaskExePropertyNameEnum** section.

For more information about the elements, attributes, and enumeration values in the following XSD fragment, see section 2.5.

```

<xs:complexType>
  <xs:sequence>
    <xs:element name="ForEachEnumerator"
      type="DTS:ForEachEnumeratorType"
      minOccurs="0" maxOccurs="0"/>
    <xs:element name="Property"
      maxOccurs="unbounded">
      <xs:complexType>
        <xs:complexContent>
          <xs:extension base="DTS:PropertyElementBaseType">
            <xs:attribute name="Name"
              type="DTS:TaskExePropertyNameEnum"
              use="required"/>
          </xs:extension>
        </xs:complexContent>
      </xs:complexType>
    </xs:element>
    <xs:element name="Variable" type="DTS:VariableType"
      minOccurs="0" maxOccurs="unbounded"/>
    <xs:element name="LoggingOptions" type="DTS:LoggingOptionsType"/>
    <xs:element name="PropertyExpression"
      type="DTS:PropertyExpressionElementType"
      minOccurs="0" maxOccurs="unbounded"/>
    <xs:element name="PrecedenceConstraint"
      type="DTS:PrecedenceConstraintType"
      minOccurs="0" maxOccurs="unbounded"/>
    <xs:element name="ForEachVariableMapping"
      type="DTS:ForEachVariableMappingType"
      minOccurs="0" maxOccurs="0"/>
    <xs:element name="EventHandler" type="DTS:EventHandlerType"
      minOccurs="0" maxOccurs="unbounded"/>
    <xs:element name="ObjectData">
      <xs:complexType>
        <xs:choice>
          <xs:element name="FtpData" type="DTS:FtpDataObjectDataType"
            form="unqualified"/>
        </xs:choice>
      </xs:complexType>
    </xs:element>
  </xs:sequence>
  <xs:attribute name="ExecutableType" use="required">
    <xs:simpleType>
      <xs:restriction base="xs:string">
        <xs:enumeration
          value="Microsoft.SqlServer.Dts.Tasks.FtpTask.FtpTask, Microsoft.SqlServer.FtpTask,
            Version=10.0.0.0, Culture=neutral, PublicKeyToken=89845dcd8080cc91"/>
      </xs:restriction>
    </xs:simpleType>
  </xs:attribute>

```

```

        <xs:enumeration value="STOCK:FTPSTask"/>
    </xs:restriction>
</xs:simpleType>
</xs:attribute>
<xs:attribute name="ThreadHint" use="optional" type="xs:int"/>
</xs:complexType>

```

2.6.3.13 ExecutableType Instance for Message Queue Task

Message Queue Task accesses data in Microsoft Message queuing (MSMQ). An executable is a Message Queue Task executable if the **ExecutableType** attribute value is one of the following:

- Microsoft.SqlServer.Dts.Tasks.MessageQueueTask.MessageQueueTask, Microsoft.SqlServer.MSMQTask, Version=10.0.0.0, Culture=neutral, PublicKeyToken=89845dcd8080cc91
- STOCK:MSMQTask

The Message Queue Task executable is formally defined to be of type [AnyNonPackageExecutableType](#). However, the following XSD fragment, which is expressed as an anonymous complex type declaration, places further restrictions on the type than the restrictions that are declared in the **AnyNonPackageExecutableType** type declaration. An [Executable](#) element with the **ExecutableType** attribute value equal to "Microsoft.SqlServer.Dts.Tasks.MessageQueueTask.MessageQueueTask, Microsoft.SqlServer.MSMQTask, Version=10.0.0.0, Culture=neutral, PublicKeyToken=89845dcd8080cc91" or "STOCK:MSMQTask" MUST follow the anonymous type declaration that is contained in this section.

Note the following differences between this anonymous complex type declaration and the full definition of the complex type for the **AnyNonPackageExecutableType** type:

- This **Executable** element MUST NOT contain an **Executable** element.
- This **Executable** element MUST NOT contain a **ForEachEnumerator** element.
- This **Executable** element MUST NOT contain a **ForEachVariableMapping** element.
- In the **AnyNonPackageExecutableType** type, the type of the **ObjectData** element is given as [ExecutableObjectDataType](#). The **ExecutableObjectDataType** type definition contains an **xs:choice** XSD Schema element. However, not all of the choices that are allowed in the **xs:choice** XSD Schema element are available for the Message Queue Task executable. For this **Executable** element, the **ObjectData** element MUST contain the [MessageQueueTaskData](#) element that is specified in the [MessageQueueTask](#) namespace.
- The allowed values for the **Name** attribute of the **Property** element are a restricted subset of the values that are allowed on the type, as specified in the **AnyNonPackageExecutablePropertyNameEnum** type. Hence, the formal type declarations of the **Property** element and the **PropertyExpression** elements are replaced in this anonymous XSD fragment with a reference to the [TaskExePropertyNameEnum](#) simple type. The **Name** attribute of the **Property** element MUST be restricted to the values that are shown as valid in the XSD fragment that is contained in the **TaskExePropertyNameEnum** section.

For more information about the elements, attributes, and enumeration values in the following XSD fragment, see section 2.5.

```

<xs:complexType>
  <xs:sequence>
    <xs:element name="ForEachEnumerator"
      type="DTS:ForEachEnumeratorType"

```

```

        minOccurs="0" maxOccurs="0"/>
<xs:element name="Property"
  maxOccurs="unbounded">
  <xs:complexType>
    <xs:complexContent>
      <xs:extension base="DTS:PropertyElementBaseType">
        <xs:attribute name="Name"
          type="DTS:TaskExePropertyNameEnum"
          use="required"/>
      </xs:extension>
    </xs:complexContent>
  </xs:complexType>
</xs:element>
<xs:element name="Variable" type="DTS:VariableType"
  minOccurs="0" maxOccurs="unbounded"/>
<xs:element name="LoggingOptions" type="DTS:LoggingOptionsType"/>
<xs:element name="PropertyExpression"
  type="DTS:PropertyExpressionElementType"
  minOccurs="0" maxOccurs="unbounded"/>
<xs:element name="PrecedenceConstraint"
  type="DTS:PrecedenceConstraintType"
  minOccurs="0" maxOccurs="unbounded"/>
<xs:element name="ForEachVariableMapping"
  type="DTS:ForEachVariableMappingType"
  minOccurs="0" maxOccurs="0"/>
<xs:element name="EventHandler" type="DTS:EventHandlerType"
  minOccurs="0" maxOccurs="unbounded"/>
<xs:element name="ObjectData">
  <xs:complexType>
    <xs:choice>
      <xs:element ref="MessageQueueTask:MessageQueueTaskData"/>
    </xs:choice>
  </xs:complexType>
</xs:element>
</xs:sequence>
<xs:attribute name="ExecutableType" use="required">
  <xs:simpleType>
    <xs:restriction base="xs:string">
      <xs:enumeration
        value="Microsoft.SqlServer.Dts.Tasks.MessageQueueTask.MessageQueueTask,
        Microsoft.SqlServer.MSMQTask, Version=10.0.0.0, Culture=neutral,
        PublicKeyToken=89845dcd8080cc91"/>
      <xs:enumeration value="STOCK:MSMQTask"/>
    </xs:restriction>
  </xs:simpleType>
</xs:attribute>
<xs:attribute name="ThreadHint" use="optional" type="xs:int"/>
</xs:complexType>

```

2.6.3.14 ExecutableType Instance for Script Task

Script Task runs custom code that is created in a programming environment within the data flow. An executable is a Script Task executable if the **ExecutableType** attribute value is one of the following:

- Microsoft.SqlServer.Dts.Tasks.ScriptTask.ScriptTask, Microsoft.SqlServer.ScriptTask, Version=10.0.0.0, Culture=neutral, PublicKeyToken=89845dcd8080cc91
- STOCK: ScriptTask

The Script Task executable is formally defined to be of type [AnyNonPackageExecutableType](#). However, the following XSD fragment, which is expressed as an anonymous complex type declaration, places further restrictions on the type than the restrictions that are declared in the **AnyNonPackageExecutableType** type declaration. An [Executable](#) element with the **ExecutableType** attribute value equal to "Microsoft.SqlServer.Dts.Tasks.ScriptTask.ScriptTask, Microsoft.SqlServer.ScriptTask, Version=10.0.0.0, Culture=neutral,

PublicKeyToken=89845dcd8080cc91" or "STOCK: ScriptTask" MUST follow the anonymous type declaration that is contained in this section.

Note the following differences between this anonymous complex type declaration and the full definition of the complex type for the **AnyNonPackageExecutableType** type:

- This **Executable** element MUST NOT contain an **Executable** element.
- This **Executable** element MUST NOT contain a **ForEachEnumerator** element.
- This **Executable** element MUST NOT contain a **ForEachVariableMapping** element.
- In the **AnyNonPackageExecutableType** type, the type of the **ObjectData** element is given as [ExecutableObjectDataType](#). The **ExecutableObjectDataType** type definition contains an **xs:choice** XSD Schema element. However, not all of the choices that are allowed in the **xs:choice** XSD Schema element are available for the Script Task executable. For this **Executable** element, the **ObjectData** element MUST contain the **ScriptProject** element of type [ScriptProjectObjectDataType](#).
- The allowed values for the **Name** attribute of the **Property** element are a restricted subset of the values that are allowed on the type, as specified in the **AnyNonPackageExecutablePropertyNameEnum** type. Hence, the formal type declarations of the **Property** element and the **PropertyExpression** elements are replaced in this anonymous XSD fragment with a reference to the [TaskExePropertyNameEnum](#) simple type. The **Name** attribute of the **Property** element MUST be restricted to the values that are shown as valid in the XSD fragment that is contained in the **TaskExePropertyNameEnum** section.

For more information about the elements, attributes, and enumeration values in the following XSD fragment, see section 2.5.

```
<xs:complexType>
  <xs:sequence>
    <xs:element name="ForEachEnumerator"
      type="DTS:ForEachEnumeratorType"
      minOccurs="0" maxOccurs="0"/>
    <xs:element name="Property"
      maxOccurs="unbounded">
      <xs:complexType>
        <xs:complexContent>
          <xs:extension base="DTS:PropertyElementBaseType">
            <xs:attribute name="Name"
              type="DTS:TaskExePropertyNameEnum"
              use="required"/>
          </xs:extension>
        </xs:complexContent>
      </xs:complexType>
    </xs:element>
    <xs:element name="Variable" type="DTS:VariableType"
      minOccurs="0" maxOccurs="unbounded"/>
    <xs:element name="LoggingOptions" type="DTS:LoggingOptionsType"/>
    <xs:element name="PropertyExpression"
      type="DTS:PropertyExpressionElementType"
      minOccurs="0" maxOccurs="unbounded"/>
    <xs:element name="PrecedenceConstraint"
      type="DTS:PrecedenceConstraintType"
      minOccurs="0" maxOccurs="unbounded"/>
    <xs:element name="ForEachVariableMapping"
      type="DTS:ForEachVariableMappingType"
      minOccurs="0" maxOccurs="0"/>
    <xs:element name="EventHandler" type="DTS:EventHandlerType"
      minOccurs="0" maxOccurs="unbounded"/>
    <xs:element name="ObjectData">
      <xs:complexType>
        <xs:choice>
          <xs:element name="ScriptProject" type="DTS:ScriptProjectObjectDataType">
```

```

        form="unqualified"/>
    </xs:choice>
</xs:complexType>
</xs:element>
</xs:sequence>
<xs:attribute name="ExecutableType" use="required">
    <xs:simpleType>
        <xs:restriction base="xs:string">
            <xs:enumeration
                value="Microsoft.SqlServer.Dts.Tasks.ScriptTask.ScriptTask,
                Microsoft.SqlServer.ScriptTask, Version=10.0.0.0, Culture=neutral,
                PublicKeyToken=89845dcd8080cc91"/>
            <xs:enumeration value="STOCK:ScriptTask"/>
        </xs:restriction>
    </xs:simpleType>
</xs:attribute>
<xs:attribute name="ThreadHint" use="optional" type="xs:int"/>
</xs:complexType>

```

2.6.3.15 ExecutableType Instance for Send Mail Task

Send Mail Task sends email messages. An executable is a Send Mail Task executable if the **ExecutableType** attribute value is one of the following:

- Microsoft.SqlServer.Dts.Tasks.SendMailTask.SendMailTask, Microsoft.SqlServer.SendMailTask, Version=10.0.0.0, Culture=neutral, PublicKeyToken=89845dcd8080cc91
- STOCK:SendMailTask

The Send Mail Task executable is formally defined to be of type [AnyNonPackageExecutableType](#). However, the following XSD fragment, which is expressed as an anonymous complex type declaration, places further restrictions on the type than the restrictions that are declared in the **AnyNonPackageExecutableType** type declaration. An [Executable](#) element with the **ExecutableType** attribute value equal to "Microsoft.SqlServer.Dts.Tasks.SendMailTask.SendMailTask, Microsoft.SqlServer.SendMailTask, Version=10.0.0.0, Culture=neutral, PublicKeyToken=89845dcd8080cc91" or "STOCK:SendMailTask" MUST follow the anonymous type declaration that is contained in this section.

Note the following differences between this anonymous complex type declaration and the full definition of the complex type for the **AnyNonPackageExecutableType** type:

- This **Executable** element MUST NOT contain an **Executable** element.
- This **Executable** element MUST NOT contain a **ForEachEnumerator** element.
- This **Executable** element MUST NOT contain a **ForEachVariableMapping** element.
- In the **AnyNonPackageExecutableType** type, the type of the **ObjectData** element is given as [ExecutableObjectDataType](#). The **ExecutableObjectDataType** type definition contains an **xs:choice** XSD Schema element. However, not all of the choices that are allowed in the **xs:choice** XSD Schema element are available for the Send Mail Task executable. For this **Executable** element, the **ObjectData** element MUST contain the [SendMailTaskData](#) element that is specified in the [SendMailTask](#) namespace.
- The allowed values for the **Name** attribute of the **Property** element are a restricted subset of the values that are allowed on the type, as specified in the **AnyNonPackageExecutablePropertyNameEnum** type. Hence, the formal type declarations of the **Property** element and the **PropertyExpression** elements are replaced in this anonymous XSD fragment with a reference to the [TaskExePropertyNameEnum](#) simple type. The **Name** attribute of the **Property** element MUST be restricted to the values that are shown as valid in the XSD fragment that is contained in that section.

For more information about the elements, attributes, and enumeration values in the following XSD fragment, see section 2.5.

```

<xs:complexType>
  <xs:sequence>
    <xs:element name="ForEachEnumerator"
      type="DTS:ForEachEnumeratorType"
      minOccurs="0" maxOccurs="0"/>
    <xs:element name="Property"
      maxOccurs="unbounded">
      <xs:complexType>
        <xs:complexContent>
          <xs:extension base="DTS:PropertyElementBaseType">
            <xs:attribute name="Name"
              type="DTS:TaskExePropertyNameEnum"
              use="required"/>
          </xs:extension>
        </xs:complexContent>
      </xs:complexType>
    </xs:element>
    <xs:element name="Variable" type="DTS:VariableType"
      minOccurs="0" maxOccurs="unbounded"/>
    <xs:element name="LoggingOptions" type="DTS:LoggingOptionsType"/>
    <xs:element name="PropertyExpression"
      type="DTS:PropertyExpressionElementType"
      minOccurs="0" maxOccurs="unbounded"/>
    <xs:element name="PrecedenceConstraint"
      type="DTS:PrecedenceConstraintType"
      minOccurs="0" maxOccurs="unbounded"/>
    <xs:element name="ForEachVariableMapping"
      type="DTS:ForEachVariableMappingType"
      minOccurs="0" maxOccurs="0"/>
    <xs:element name="EventHandler" type="DTS:EventHandlerType"
      minOccurs="0" maxOccurs="unbounded"/>
    <xs:element name="ObjectData">
      <xs:complexType>
        <xs:choice>
          <xs:element ref="SendMailTask:SendMailTaskData"/>
        </xs:choice>
      </xs:complexType>
    </xs:element>
  </xs:sequence>
  <xs:attribute name="ExecutableType" use="required">
    <xs:simpleType>
      <xs:restriction base="xs:string">
        <xs:enumeration
          value="Microsoft.SqlServer.Dts.Tasks.SendMailTask.SendMailTask,
            Microsoft.SqlServer.SendMailTask, Version=10.0.0.0, Culture=neutral,
            PublicKeyToken=89845dcd8080cc91"/>
        <xs:enumeration value="STOCK:SendMailTask"/>
      </xs:restriction>
    </xs:simpleType>
  </xs:attribute>
  <xs:attribute name="ThreadHint" use="optional" type="xs:int"/>
</xs:complexType>

```

2.6.3.16 ExecutableType Instance for Transfer Database Task

Transfer Database Task copies or moves a database between different instances of the database server. An executable is a Transfer Database Task executable if the **ExecutableType** attribute value is one of the following:

- Microsoft.SqlServer.Dts.Tasks.TransferDatabaseTask.TransferDatabaseTask, Microsoft.SqlServer.TransferDatabasesTask, Version=10.0.0.0, Culture=neutral, PublicKeyToken=89845dcd8080cc91

- STOCK:TransferDatabaseTask

The Transfer Database Task executable is formally defined to be of type [AnyNonPackageExecutableType](#). However, the following XSD fragment, which is expressed as an anonymous complex type declaration, places further restrictions on the type than the restrictions that are declared in the **AnyNonPackageExecutableType** type declaration. An [Executable](#) element with the **ExecutableType** attribute value equal to "Microsoft.SqlServer.Dts.Tasks.TransferDatabaseTask.TransferDatabaseTask, Microsoft.SqlServer.TransferDatabasesTask, Version=10.0.0.0, Culture=neutral, PublicKeyToken=89845dcd8080cc91" or "STOCK:TransferDatabaseTask" MUST follow the anonymous type declaration that is contained in this section.

Note the following differences between this anonymous complex type declaration and the full definition of the complex type for the **AnyNonPackageExecutableType** type:

- This **Executable** element MUST NOT contain an **Executable** element.
- This **Executable** element MUST NOT contain a **ForEachEnumerator** element.
- This **Executable** element MUST NOT contain a **ForEachVariableMapping** element.
- In the **AnyNonPackageExecutableType** type, the type of the **ObjectData** element is given as [ExecutableObjectDataType](#). The **ExecutableObjectDataType** type definition contains an **xs:choice** XSD Schema element. However, not all of the choices that are allowed in the **xs:choice** XSD Schema element are available for the Transfer Database Task executable. For this **Executable** element, the **ObjectData** element MUST contain the **TransferDatabaseTaskData** element of type [TransferDatabaseTaskDataObjectDataType](#).
- The allowed values for the **Name** attribute of the **Property** element are a restricted subset of the values that are allowed on the type, as specified in the **AnyNonPackageExecutablePropertyNameEnum** type. Hence, the formal type declarations of the **Property** element and the **PropertyExpression** elements are replaced in this anonymous XSD fragment with a reference to the [TaskExePropertyNameEnum](#) simple type. The **Name** attribute of the **Property** element MUST be restricted to the values that are shown as valid in the XSD fragment that is contained in the **TaskExePropertyNameEnum** section.

For more information about the elements, attributes, and enumeration values in the following XSD fragment, see section 2.5.

```
<xs:complexType>
  <xs:sequence>
    <xs:element name="ForEachEnumerator"
      type="DTS:ForEachEnumeratorType"
      minOccurs="0" maxOccurs="0"/>
    <xs:element name="Property"
      maxOccurs="unbounded">
      <xs:complexType>
        <xs:complexContent>
          <xs:extension base="DTS:PropertyElementBaseType">
            <xs:attribute name="Name"
              type="DTS:TaskExePropertyNameEnum"
              use="required"/>
          </xs:extension>
        </xs:complexContent>
      </xs:complexType>
    </xs:element>
    <xs:element name="Variable" type="DTS:VariableType"
      minOccurs="0" maxOccurs="unbounded"/>
    <xs:element name="LoggingOptions" type="DTS:LoggingOptionsType"/>
    <xs:element name="PropertyExpression"
      type="DTS:PropertyExpressionElementType"
      minOccurs="0" maxOccurs="unbounded"/>
    <xs:element name="PrecedenceConstraint">
```

```

        type="DTS:PrecedenceConstraintType"
        minOccurs="0" maxOccurs="unbounded"/>
<xs:element name="ForEachVariableMapping"
    type="DTS:ForEachVariableMappingType"
    minOccurs="0" maxOccurs="0"/>
<xs:element name="EventHandler" type="DTS:EventHandlerType"
    minOccurs="0" maxOccurs="unbounded"/>
<xs:element name="ObjectData">
    <xs:complexType>
        <xs:choice>
            <xs:element name="TransferDatabasesTaskData" form="unqualified"
                type="DTS:TransferDatabasesTaskDataObjectData"/>
        </xs:choice>
    </xs:complexType>
</xs:element>
</xs:sequence>
<xs:attribute name="ExecutableType" use="required">
    <xs:simpleType>
        <xs:restriction base="xs:string">
            <xs:enumeration
                value="Microsoft.SqlServer.Dts.Tasks.TransferDatabaseTask.TransferDatabaseTask,
                    Microsoft.SqlServer.TransferDatabasesTask, Version=10.0.0.0, Culture=neutral,
                    PublicKeyToken=89845dcd8080cc91"/>
            <xs:enumeration value="STOCK:TransferDatabaseTask"/>
        </xs:restriction>
    </xs:simpleType>
</xs:attribute>
<xs:attribute name="ThreadHint" use="optional" type="xs:int"/>
</xs:complexType>

```

2.6.3.17 ExecutableType Instance for Transfer Error Messages Task

Transfer Error Messages Task transfers user-defined error messages between instances of a database. An executable is a Transfer Error Messages Task executable if the **ExecutableType** attribute value is one of the following:

- Microsoft.SqlServer.Dts.Tasks.TransferErrorMessagesTask.TransferErrorMessagesTask, Microsoft.SqlServer.TransferErrorMessagesTask, Version=10.0.0.0, Culture=neutral, PublicKeyToken=89845dcd8080cc91
- STOCK:TransferErrorMessagesTask

The Transfer Error Messages Task executable is formally defined to be of type [AnyNonPackageExecutableType](#). However, the following XSD fragment, which is expressed as an anonymous complex type declaration, places further restrictions on the type than the restrictions that are declared in the **AnyNonPackageExecutableType** type declaration. An [Executable](#) element with the **ExecutableType** attribute value equal to

"Microsoft.SqlServer.Dts.Tasks.TransferErrorMessagesTask.TransferErrorMessagesTask, Microsoft.SqlServer.TransferErrorMessagesTask, Version=10.0.0.0, Culture=neutral, PublicKeyToken=89845dcd8080cc91" or "STOCK:TransferErrorMessagesTask" MUST follow the anonymous type declaration that is contained in this section.

Note the following differences between this anonymous complex type declaration and the full definition of the complex type for the **AnyNonPackageExecutableType** type:

- This **Executable** element MUST NOT contain an **Executable** element.
- This **Executable** element MUST NOT contain a **ForEachEnumerator** element.
- This **Executable** element MUST NOT contain a **ForEachVariableMapping** element.

- In the **AnyNonPackageExecutableType** type, the type of the **ObjectData** element is given as [ExecutableObjectDataType](#). The **ExecutableObjectDataType** type definition contains an **xs:choice** XSD Schema element. However, not all of the choices that are allowed in the **xs:choice** XSD Schema element are available for the Transfer Error Messages Task executable. For this **Executable** element, the **ObjectData** element MUST contain the **TransferErrorMessagesTaskData** element of type [TransferErrorMessagesTaskDataObjectDataType](#).
- The allowed values for the **Name** attribute of the **Property** element are a restricted subset of the values that are allowed on the type, as specified in the **AnyNonPackageExecutablePropertyNameEnum** type. Hence, the formal type declarations of the **Property** element and the **PropertyExpression** elements are replaced in this anonymous XSD fragment with a reference to the [TaskExePropertyNameEnum](#) simple type. The **Name** attribute of the **Property** element MUST be restricted to the values that are shown as valid in the XSD fragment that is contained in the **TaskExePropertyNameEnum** section.

For more information about the elements, attributes, and enumeration values in the following XSD fragment, see section 2.5.

```
<xs:complexType>
  <xs:sequence>
    <xs:element name="ForEachEnumerator"
      type="DTS:ForEachEnumeratorType"
      minOccurs="0" maxOccurs="0"/>
    <xs:element name="Property"
      maxOccurs="unbounded">
      <xs:complexType>
        <xs:complexContent>
          <xs:extension base="DTS:PropertyElementBaseType">
            <xs:attribute name="Name"
              type="DTS:TaskExePropertyNameEnum"
              use="required"/>
          </xs:extension>
        </xs:complexContent>
      </xs:complexType>
    </xs:element>
    <xs:element name="Variable" type="DTS:VariableType"
      minOccurs="0" maxOccurs="unbounded"/>
    <xs:element name="LoggingOptions" type="DTS:LoggingOptionsType"/>
    <xs:element name="PropertyExpression"
      type="DTS:PropertyExpressionElementType"
      minOccurs="0" maxOccurs="unbounded"/>
    <xs:element name="PrecedenceConstraint"
      type="DTS:PrecedenceConstraintType"
      minOccurs="0" maxOccurs="unbounded"/>
    <xs:element name="ForEachVariableMapping"
      type="DTS:ForEachVariableMappingType"
      minOccurs="0" maxOccurs="0"/>
    <xs:element name="EventHandler" type="DTS:EventHandlerType"
      minOccurs="0" maxOccurs="unbounded"/>
    <xs:element name="ObjectData">
      <xs:complexType>
        <xs:choice>
          <xs:element name="TransferErrorMessagesTaskData" form="unqualified"
            type="DTS:TransferErrorMessagesTaskDataObjectDataType"/>
        </xs:choice>
      </xs:complexType>
    </xs:element>
  </xs:sequence>
  <xs:attribute name="ExecutableType" use="required">
    <xs:simpleType>
      <xs:restriction base="xs:string">
        <xs:enumeration
          value="Microsoft.SqlServer.Dts.Tasks.TransferErrorMessagesTask.TransferErrorMessagesTask,
            Microsoft.SqlServer.TransferErrorMessagesTask, Version=10.0.0.0, Culture=neutral,
            PublicKeyToken=89845dcd8080cc91"/>
      </xs:restriction>
    </xs:simpleType>
  </xs:attribute>

```

```

        <xs:enumeration value="STOCK:TransferErrorMessagesTask"/>
    </xs:restriction>
</xs:simpleType>
</xs:attribute>
<xs:attribute name="ThreadHint" use="optional" type="xs:int"/>
</xs:complexType>

```

2.6.3.18 ExecutableType Instance for Transfer Jobs Task

Transfer Jobs Task transfers SQL Server Agent Jobs between instances of a Microsoft SQL Server database. An executable is a Transfer Jobs Task executable if the **ExecutableType** attribute value is one of the following:

- Microsoft.SqlServer.Dts.Tasks.TransferJobsTask.TransferJobsTask, Microsoft.SqlServer.TransferJobsTask, Version=10.0.0.0, Culture=neutral, PublicKeyToken=89845dcd8080cc91
- STOCK:TransferJobsTask

The Transfer Jobs Task executable is formally defined to be of type [AnyNonPackageExecutableType](#). However, the following XSD fragment, which is expressed as an anonymous complex type declaration, places further restrictions on the type than the restrictions that are declared in the **AnyNonPackageExecutableType** type declaration. An [Executable](#) element with the **ExecutableType** attribute value equal to "Microsoft.SqlServer.Dts.Tasks.TransferJobsTask.TransferJobsTask, Microsoft.SqlServer.TransferJobsTask, Version=10.0.0.0, Culture=neutral, PublicKeyToken=89845dcd8080cc91" or "STOCK:TransferJobsTask" MUST follow the anonymous type declaration that is contained in this section.

Note the following differences between this anonymous complex type declaration and the full definition of the complex type for the **AnyNonPackageExecutableType** type:

- This **Executable** element MUST NOT contain an **Executable** element.
- This **Executable** element MUST NOT contain a **ForEachEnumerator** element.
- This **Executable** element MUST NOT contain a **ForEachVariableMapping** element.
- In the **AnyNonPackageExecutableType** type, the type of the **ObjectData** element is given as [ExecutableObjectDataType](#). The **ExecutableObjectDataType** type definition contains an **xs:choice** XSD Schema element. However, not all of the choices that are allowed in the **xs:choice** XSD Schema element are available for the Transfer Jobs Task executable. For this **Executable** element, the **ObjectData** element MUST contain the **TransferJobsTaskData** element of type [TransferJobsTaskDataObjectType](#).
- The allowed values for the **Name** attribute of the **Property** element are a restricted subset of the values that are allowed on the type, as specified in the **AnyNonPackageExecutablePropertyNameEnum** type. Hence, the formal type declarations of the **Property** element and the **PropertyExpression** elements are replaced in this anonymous XSD fragment with a reference to the [TaskExePropertyNameEnum](#) simple type. The **Name** attribute of the **Property** element MUST be restricted to the values that are shown as valid in the XSD fragment that is contained in the **TaskExePropertyNameEnum** section.

For more information about the elements, attributes, and enumeration values in the following XSD fragment, see section 2.5.

```

<xs:complexType>
  <xs:sequence>
    <xs:element name="ForEachEnumerator"

```

```

        type="DTS:ForEachEnumeratorType"
        minOccurs="0" maxOccurs="0"/>
<xs:element name="Property"
        maxOccurs="unbounded">
  <xs:complexType>
    <xs:complexContent>
      <xs:extension base="DTS:PropertyElementBaseType">
        <xs:attribute name="Name"
          type="DTS:TaskExePropertyNameEnum"
          use="required"/>
      </xs:extension>
    </xs:complexContent>
  </xs:complexType>
</xs:element>
<xs:element name="Variable" type="DTS:VariableType"
  minOccurs="0" maxOccurs="unbounded"/>
<xs:element name="LoggingOptions" type="DTS:LoggingOptionsType"/>
<xs:element name="PropertyExpression"
  type="DTS:PropertyExpressionElementType"
  minOccurs="0" maxOccurs="unbounded"/>
<xs:element name="PrecedenceConstraint"
  type="DTS:PrecedenceConstraintType"
  minOccurs="0" maxOccurs="unbounded"/>
<xs:element name="ForEachVariableMapping"
  type="DTS:ForEachVariableMappingType"
  minOccurs="0" maxOccurs="0"/>
<xs:element name="EventHandler" type="DTS:EventHandlerType"
  minOccurs="0" maxOccurs="unbounded"/>
<xs:element name="ObjectData">
  <xs:complexType>
    <xs:choice>
      <xs:element name="TransferJobsTaskData" form="unqualified"
        type="DTS:TransferJobsTaskDataObjectDataType"/>
    </xs:choice>
  </xs:complexType>
</xs:element>
</xs:sequence>
<xs:attribute name="ExecutableType" use="required">
  <xs:simpleType>
    <xs:restriction base="xs:string">
      <xs:enumeration
        value="Microsoft.SqlServer.Dts.Tasks.TransferJobsTask.TransferJobsTask,
        Microsoft.SqlServer.TransferJobsTask, Version=10.0.0.0, Culture=neutral,
        PublicKeyToken=89845dcd8080cc91"/>
      <xs:enumeration value="STOCK:TransferJobsTask"/>
    </xs:restriction>
  </xs:simpleType>
</xs:attribute>
<xs:attribute name="ThreadHint" use="optional" type="xs:int"/>
</xs:complexType>

```

2.6.3.19 ExecutableType Instance for Transfer Logins Task

Transfer Logins Task transfers user logins between instances of a database. An executable is a Transfer Logins Task executable if the **ExecutableType** attribute value is one of the following:

- Microsoft.SqlServer.Dts.Tasks.TransferLoginsTask.TransferLoginsTask, Microsoft.SqlServer.TransferLoginsTask, Version=10.0.0.0, Culture=neutral, PublicKeyToken=89845dcd8080cc91
- STOCK:TransferLoginsTask

The Transfer Logins Task executable is formally defined to be of type [AnyNonPackageExecutableType](#). However, the following XSD fragment, which is expressed as an anonymous complex type declaration, places further restrictions on the type than the restrictions that are declared in the

AnyNonPackageExecutableType type declaration. An [Executable](#) element with the **ExecutableType** attribute value equal to "Microsoft.SqlServer.Dts.Tasks.TransferLoginsTask.TransferLoginsTask, Microsoft.SqlServer.TransferLoginsTask, Version=10.0.0.0, Culture=neutral, PublicKeyToken=89845dcd8080cc91" or "STOCK:TransferLoginsTask" MUST follow the anonymous type declaration that is contained in this section.

Note the following differences between this anonymous complex type declaration and the full definition of the complex type for the **AnyNonPackageExecutableType** type:

- This **Executable** element MUST NOT contain an **Executable** element.
- This **Executable** element MUST NOT contain a **ForEachEnumerator** element.
- This **Executable** element MUST NOT contain a **ForEachVariableMapping** element.
- In the **AnyNonPackageExecutableType** type, the type of the **ObjectData** element is given as [ExecutableObjectDataType](#). The **ExecutableObjectDataType** type definition contains an **xs:choice** XSD Schema element. However, not all of the choices that are allowed in the **xs:choice** XSD Schema element are available for the Transfer Logins Task executable. For this **Executable** element, the **ObjectData** element MUST contain the **TransferLoginsTaskData** element of type [TransferLoginsTaskDataObjectDataType](#).
- The allowed values for the **Name** attribute of the **Property** element are a restricted subset of the values that are allowed on the type, as specified in the **AnyNonPackageExecutablePropertyNameEnum** type. Hence, the formal type declarations of the **Property** element and the **PropertyExpression** elements are replaced in this anonymous XSD fragment with a reference to the [TaskExePropertyNameEnum](#) simple type. The **Name** attribute of the **Property** element MUST be restricted to the values that are shown as valid in the XSD fragment that is contained in **TaskExePropertyNameEnum** section.

For more information about the elements, attributes, and enumeration values in the following XSD fragment, see section 2.5.

```
<xs:complexType>
  <xs:sequence>
    <xs:element name="ForEachEnumerator"
      type="DTS:ForEachEnumeratorType"
      minOccurs="0" maxOccurs="0"/>
    <xs:element name="Property"
      maxOccurs="unbounded">
      <xs:complexType>
        <xs:complexContent>
          <xs:extension base="DTS:PropertyElementBaseType">
            <xs:attribute name="Name"
              type="DTS:TaskExePropertyNameEnum"
              use="required"/>
          </xs:extension>
        </xs:complexContent>
      </xs:complexType>
    </xs:element>
    <xs:element name="Variable" type="DTS:VariableType"
      minOccurs="0" maxOccurs="unbounded"/>
    <xs:element name="LoggingOptions" type="DTS:LoggingOptionsType"/>
    <xs:element name="PropertyExpression"
      type="DTS:PropertyExpressionElementType"
      minOccurs="0" maxOccurs="unbounded"/>
    <xs:element name="PrecedenceConstraint"
      type="DTS:PrecedenceConstraintType"
      minOccurs="0" maxOccurs="unbounded"/>
    <xs:element name="ForEachVariableMapping"
      type="DTS:ForEachVariableMappingType"
      minOccurs="0" maxOccurs="0"/>
    <xs:element name="EventHandler" type="DTS:EventHandlerType"
```

```

        minOccurs="0" maxOccurs="unbounded"/>
<xs:element name="ObjectData">
  <xs:complexType>
    <xs:choice>
      <xs:element name="TransferLoginsTaskData" form="unqualified"
        type="DTS:TransferLoginsTaskDataObjectDataType"/>
    </xs:choice>
  </xs:complexType>
</xs:element>
</xs:sequence>
<xs:attribute name="ExecutableType" use="required">
  <xs:simpleType>
    <xs:restriction base="xs:string">
      <xs:enumeration
        value="Microsoft.SqlServer.Dts.Tasks.TransferLoginsTask.TransferLoginsTask,
        Microsoft.SqlServer.TransferLoginsTask, Version=10.0.0.0, Culture=neutral,
        PublicKeyToken=89845dcd8080cc91"/>
      <xs:enumeration value="STOCK:TransferLoginsTask"/>
    </xs:restriction>
  </xs:simpleType>
</xs:attribute>
<xs:attribute name="ThreadHint" use="optional" type="xs:int"/>
</xs:complexType>

```

2.6.3.20 ExecutableType Instance for Transfer Stored Procedures Task

Transfer Stored Procedures Task transfers stored procedures between database instances. An executable is a Transfer Stored Procedures Task executable if the **ExecutableType** attribute value is one of the following:

- Microsoft.SqlServer.Dts.Tasks.TransferStoredProceduresTask.TransferStoredProceduresTask, Microsoft.SqlServer.TransferStoredProceduresTask, Version=10.0.0.0, Culture=neutral, PublicKeyToken=89845dcd8080cc91
- STOCK:TransferStoredProceduresTask

The Transfer Stored Procedures Task executable is formally defined to be of type [AnyNonPackageExecutableType](#). However, the following XSD fragment, which is expressed as an anonymous complex type declaration, places further restrictions on the type than the restrictions that are declared in the **AnyNonPackageExecutableType** type declaration. An [Executable](#) element with the **ExecutableType** attribute value equal to "Microsoft.SqlServer.Dts.Tasks.TransferStoredProceduresTask.TransferStoredProceduresTask, Microsoft.SqlServer.TransferStoredProceduresTask, Version=10.0.0.0, Culture=neutral, PublicKeyToken=89845dcd8080cc91" or "STOCK:TransferStoredProceduresTask" MUST follow the anonymous type declaration that is contained in this section.

Note the following differences between this anonymous complex type declaration and the full definition of the complex type for the **AnyNonPackageExecutableType** type:

- This **Executable** element MUST NOT contain an **Executable** element.
- This **Executable** element MUST NOT contain a **ForEachEnumerator** element.
- This **Executable** element MUST NOT contain a **ForEachVariableMapping** element.
- In the **AnyNonPackageExecutableType** type, the type of the **ObjectData** element is given as [ExecutableObjectDataType](#). The **ExecutableObjectDataType** type definition contains an **xs:choice** XSD Schema element. However, not all of the choices that are allowed in the **xs:choice** XSD Schema element are available for the Transfer Stored Procedures Task executable. For this **Executable** element, the **ObjectData** element MUST contain the

TransferStoredProceduresTaskData element of type [TransferStoredProceduresTaskDataObjectType](#).

- The allowed values for the **Name** attribute of the **Property** element are a restricted subset of the values that are allowed on the type, as specified in the **AnyNonPackageExecutablePropertyNameEnum** type. Hence, the formal type declarations of the **Property** element and the **PropertyExpression** elements are replaced in this anonymous XSD fragment with a reference to the [TaskExePropertyNameEnum](#) simple type. The **Name** attribute of the **Property** element MUST be restricted to the values that are shown as valid in the XSD fragment that is contained in the **TaskExePropertyNameEnum** section.

For more information about the elements, attributes, and enumeration values in the following XSD fragment, see section 2.5.

```
<xs:complexType>
  <xs:sequence>
    <xs:element name="ForEachEnumerator"
      type="DTS:ForEachEnumeratorType"
      minOccurs="0" maxOccurs="0"/>
    <xs:element name="Property"
      maxOccurs="unbounded">
      <xs:complexType>
        <xs:complexContent>
          <xs:extension base="DTS:PropertyElementBaseType">
            <xs:attribute name="Name"
              type="DTS:TaskExePropertyNameEnum"
              use="required"/>
          </xs:extension>
        </xs:complexContent>
      </xs:complexType>
    </xs:element>
    <xs:element name="Variable" type="DTS:VariableType"
      minOccurs="0" maxOccurs="unbounded"/>
    <xs:element name="LoggingOptions" type="DTS:LoggingOptionsType"/>
    <xs:element name="PropertyExpression"
      type="DTS:PropertyExpressionElementType"
      minOccurs="0" maxOccurs="unbounded"/>
    <xs:element name="PrecedenceConstraint"
      type="DTS:PrecedenceConstraintType"
      minOccurs="0" maxOccurs="unbounded"/>
    <xs:element name="ForEachVariableMapping"
      type="DTS:ForEachVariableMappingType"
      minOccurs="0" maxOccurs="0"/>
    <xs:element name="EventHandler" type="DTS:EventHandlerType"
      minOccurs="0" maxOccurs="unbounded"/>
    <xs:element name="ObjectData">
      <xs:complexType>
        <xs:choice>
          <xs:element name="TransferStoredProceduresTaskData" form="unqualified"
            type="DTS:TransferStoredProceduresTaskDataObjectType"/>
        </xs:choice>
      </xs:complexType>
    </xs:element>
  </xs:sequence>
  <xs:attribute name="ExecutableType" use="required">
    <xs:simpleType>
      <xs:restriction base="xs:string">
        <xs:enumeration
          value="Microsoft.SqlServer.Dts.Tasks.TransferStoredProceduresTask.TransferStoredProceduresTask, Microsoft.SqlServer.TransferStoredProceduresTask, Version=10.0.0.0, Culture=neutral, PublicKeyToken=89845dcd8080cc91"/>
        <xs:enumeration value="STOCK:TransferStoredProceduresTask"/>
      </xs:restriction>
    </xs:simpleType>
  </xs:attribute>
  <xs:attribute name="ThreadHint" use="optional" type="xs:int"/>

```

```
</xs:complexType>
```

2.6.3.21 ExecutableType Instance for Transfer SQL Server Objects Task

Transfer SQL Server Objects Task transfers objects between instances of Microsoft SQL Server. An executable is a Transfer SQL Server Objects Task executable if the **ExecutableType** attribute value is one of the following:

- Microsoft.SqlServer.Dts.Tasks.TransferSqlServerObjectsTask.TransferSqlServerObjectsTask, Microsoft.SqlServer.TransferSqlServerObjectsTask, Version=10.0.0.0, Culture=neutral, PublicKeyToken=89845dcd8080cc91
- STOCK:TransferObjectsTask

The Transfer SQL Server Objects Task executable is formally defined to be of type [AnyNonPackageExecutableType](#). However, the following XSD fragment, which is expressed as an anonymous complex type declaration, places further restrictions on the type than the restrictions that are declared in the **AnyNonPackageExecutableType** type declaration. An [Executable](#) element with the **ExecutableType** attribute value equal to "Microsoft.SqlServer.Dts.Tasks.TransferSqlServerObjectsTask.TransferSqlServerObjectsTask, Microsoft.SqlServer.TransferSqlServerObjectsTask, Version=10.0.0.0, Culture=neutral, PublicKeyToken=89845dcd8080cc91" or "STOCK:TransferObjectsTask" MUST follow the anonymous type declaration that is contained in this section.

Note the following differences between this anonymous complex type declaration and the full definition of the complex type for the **AnyNonPackageExecutableType** type:

- This **Executable** element MUST NOT contain an **Executable** element.
- This **Executable** element MUST NOT contain a **ForEachEnumerator** element.
- This **Executable** element MUST NOT contain a **ForEachVariableMapping** element.
- In the **AnyNonPackageExecutableType** type, the type of the **ObjectData** element is given as [ExecutableObjectDataType](#). The **ExecutableObjectDataType** type definition contains an **xs:choice** XSD Schema element. However, not all of the choices that are allowed in the **xs:choice** XSD Schema element are available for the Transfer SQL Server Objects Task executable. For this **Executable** element, the **ObjectData** element MUST contain the **TransferSqlServerObjectsTaskData** element of type [TransferSqlServerObjectsTaskDataObjectDataType](#).
- The allowed values for the **Name** attribute of the **Property** element are a restricted subset of the values that are allowed on the type, as specified in the **AnyNonPackageExecutablePropertyNameEnum** type. Hence, the formal type declarations of the **Property** element and the **PropertyExpression** elements are replaced in this anonymous XSD fragment with a reference to the [TaskExePropertyNameEnum](#) simple type. The **Name** attribute of the **Property** element MUST be restricted to the values that are shown as valid in the XSD fragment that is contained in the **TaskExePropertyNameEnum** section.

For more information about the elements, attributes, and enumeration values in the following XSD fragment, see section 2.5.

```
<xs:complexType>
  <xs:sequence>
    <xs:element name="ForEachEnumerator"
      type="DTS:ForEachEnumeratorType"
      minOccurs="0" maxOccurs="0"/>
    <xs:element name="Property"
      maxOccurs="unbounded">
```

```

    <xs:complexType>
      <xs:complexContent>
        <xs:extension base="DTS:PropertyElementBaseType">
          <xs:attribute name="Name"
            type="DTS:TaskExePropertyNameEnum"
            use="required"/>
        </xs:extension>
      </xs:complexContent>
    </xs:complexType>
  </xs:element>
  <xs:element name="Variable" type="DTS:VariableType"
    minOccurs="0" maxOccurs="unbounded"/>
  <xs:element name="LoggingOptions" type="DTS:LoggingOptionsType"/>
  <xs:element name="PropertyExpression"
    type="DTS:PropertyExpressionElementType"
    minOccurs="0" maxOccurs="unbounded"/>
  <xs:element name="PrecedenceConstraint"
    type="DTS:PrecedenceConstraintType"
    minOccurs="0" maxOccurs="unbounded"/>
  <xs:element name="ForEachVariableMapping"
    type="DTS:ForEachVariableMappingType"
    minOccurs="0" maxOccurs="0"/>
  <xs:element name="EventHandler" type="DTS:EventHandlerType"
    minOccurs="0" maxOccurs="unbounded"/>
  <xs:element name="ObjectData">
    <xs:complexType>
      <xs:choice>
        <xs:element name="TransferSqlServerObjectsTaskData" form="unqualified"
          type="DTS:TransferSqlServerObjectsTaskDataObjectDataType"/>
      </xs:choice>
    </xs:complexType>
  </xs:element>
</xs:sequence>
<xs:attribute name="ExecutableType" use="required">
  <xs:simpleType>
    <xs:restriction base="xs:string">
      <xs:enumeration
        value="Microsoft.SqlServer.Dts.Tasks.TransferSqlServerObjectsTask.TransferSqlServerObjectsTask, Microsoft.SqlServer.TransferSqlServerObjectsTask, Version=10.0.0.0, Culture=neutral, PublicKeyToken=89845dcd8080cc91"/>
      <xs:enumeration value="STOCK:TransferObjectsTask"/>
    </xs:restriction>
  </xs:simpleType>
</xs:attribute>
<xs:attribute name="ThreadHint" use="optional" type="xs:int"/>
</xs:complexType>

```

2.6.3.22 ExecutableType Instance for Web Service Task

Web Service Task executes a call to a web service method. An executable is a Web Service Task executable if the **ExecutableType** attribute value is one of the following:

- Microsoft.SqlServer.Dts.Tasks.WebServiceTask.WebServiceTask, Microsoft.SqlServer.WebServiceTask, Version=10.0.0.0, Culture=neutral, PublicKeyToken=89845dcd8080cc91
- STOCK:WebServiceTask

The Web Service Task executable is formally defined to be of type [AnyNonPackageExecutableType](#). However, the following XSD fragment, which is expressed as an anonymous complex type declaration, places further restrictions on the type than the restrictions that are declared in the **AnyNonPackageExecutableType** type declaration. An [Executable](#) element with the **ExecutableType** attribute value equal to "Microsoft.SqlServer.Dts.Tasks.WebServiceTask.WebServiceTask,

Microsoft.SqlServer.WebServiceTask, Version=10.0.0.0, Culture=neutral, PublicKeyToken=89845dcd8080cc91" or "STOCK:WebServiceTask" MUST follow the anonymous type declaration that is contained in this section.

Note the following differences between this anonymous complex type declaration and the full definition of the complex type for the **AnyNonPackageExecutableType** type:

- This **Executable** element MUST NOT contain an **Executable** element.
- This **Executable** element MUST NOT contain a **ForEachEnumerator** element.
- This **Executable** element MUST NOT contain a **ForEachVariableMapping** element.
- In the **AnyNonPackageExecutableType** type, the type of the **ObjectData** element is given as [ExecutableObjectDataType](#). The **ExecutableObjectDataType** type definition contains an **xs:choice** XSD Schema element. However, not all of the choices that are allowed in the **xs:choice** XSD Schema element are available for the Web Service Task executable. For this **Executable** element, the **ObjectData** element MUST contain the [WebServiceTaskData](#) element that is specified in the [WebServiceTask](#) namespace.
- The allowed values for the **Name** attribute of the **Property** element are a restricted subset of the values that are allowed on the type, as specified in the **AnyNonPackageExecutablePropertyNameEnum** type. Hence, the formal type declarations of the **Property** element and the **PropertyExpression** elements are replaced in this anonymous XSD fragment with a reference to the [TaskExePropertyNameEnum](#) simple type. The **Name** attribute of the **Property** element MUST be restricted to the values that are shown as valid in the XSD fragment that is contained in the **TaskExePropertyNameEnum** section.

For more information about the elements, attributes, and enumeration values in the following XSD fragment, see section 2.5.

```
<xs:complexType>
  <xs:sequence>
    <xs:element name="ForEachEnumerator"
      type="DTS:ForEachEnumeratorType"
      minOccurs="0" maxOccurs="0"/>
    <xs:element name="Property"
      maxOccurs="unbounded">
      <xs:complexType>
        <xs:complexContent>
          <xs:extension base="DTS:PropertyElementBaseType">
            <xs:attribute name="Name"
              type="DTS:TaskExePropertyNameEnum"
              use="required"/>
          </xs:extension>
        </xs:complexContent>
      </xs:complexType>
    </xs:element>
    <xs:element name="Variable" type="DTS:VariableType"
      minOccurs="0" maxOccurs="unbounded"/>
    <xs:element name="LoggingOptions" type="DTS:LoggingOptionsType"/>
    <xs:element name="PropertyExpression"
      type="DTS:PropertyExpressionElementType"
      minOccurs="0" maxOccurs="unbounded"/>
    <xs:element name="PrecedenceConstraint"
      type="DTS:PrecedenceConstraintType"
      minOccurs="0" maxOccurs="unbounded"/>
    <xs:element name="ForEachVariableMapping"
      type="DTS:ForEachVariableMappingType"
      minOccurs="0" maxOccurs="0"/>
    <xs:element name="EventHandler" type="DTS:EventHandlerType"
      minOccurs="0" maxOccurs="unbounded"/>
    <xs:element name="ObjectData">
      <xs:complexType>
```

```

        <xs:choice>
          <xs:element ref="WSTask:WebServiceTaskData"/>
        </xs:choice>
      </xs:complexType>
    </xs:element>
  </xs:sequence>
  <xs:attribute name="ExecutableType" use="required">
    <xs:simpleType>
      <xs:restriction base="xs:string">
        <xs:enumeration
          value="Microsoft.SqlServer.Dts.Tasks.WebServiceTask.WebServiceTask,
Microsoft.SqlServer.WebServiceTask, Version=10.0.0.0, Culture=neutral,
PublicKeyToken=89845dcd8080cc91"/>
        <xs:enumeration value="STOCK:WebServiceTask"/>
      </xs:restriction>
    </xs:simpleType>
  </xs:attribute>
  <xs:attribute name="ThreadHint" use="optional" type="xs:int"/>
</xs:complexType>

```

2.6.3.23 ExecutableType Instance for WMI Data Reader Task

Windows Management Instrumentation (WMI) Data Reader Task runs queries by using the WMI Query Language (WQL) that returns information from WMI about a computer system. An executable is a WMI Data Reader Task executable if the **ExecutableType** attribute value is one of the following:

- Microsoft.SqlServer.Dts.Tasks.WmiDataReaderTask.WmiDataReaderTask, Microsoft.SqlServer.WMIDRTask, Version=10.0.0.0, Culture=neutral, PublicKeyToken=89845dcd8080cc91
- STOCK:WmiDataReaderTask

The WMI Data Reader Task executable is formally defined to be of type [AnyNonPackageExecutableType](#). However, the following XSD fragment, which is expressed as an anonymous complex type declaration, places further restrictions on the type than the restrictions that are declared in the **AnyNonPackageExecutableNameEnum** type declaration. An [Executable](#) element with the **ExecutableType** attribute value equal to "Microsoft.SqlServer.Dts.Tasks.WmiDataReaderTask.WmiDataReaderTask, Microsoft.SqlServer.WMIDRTask, Version=10.0.0.0, Culture=neutral, PublicKeyToken=89845dcd8080cc91" or "STOCK:WmiDataReaderTask" MUST follow the anonymous type declaration that is contained in this section.

Note the following differences between this anonymous complex type declaration and the full definition of the complex type for the **AnyNonPackageExecutableType** type:

- This **Executable** element MUST NOT contain an **Executable** element.
- This **Executable** element MUST NOT contain a **ForEachEnumerator** element.
- This **Executable** element MUST NOT contain a **ForEachVariableMapping** element.
- In the **AnyNonPackageExecutableType** type, the type of the **ObjectData** element is given as [ExecutableObjectDataType](#). The **ExecutableObjectDataType** type definition contains an **xs:choice** XSD Schema element. However, not all of the choices that are allowed in the **xs:choice** XSD Schema element are available for the WMI Data Reader Task executable. For this **Executable** element, the **ObjectData** element MUST contain the **WMIDRTaskData** element of type [WMIDRTaskDataObjectDataType](#).
- The allowed values for the **Name** attribute of the **Property** element are a restricted subset of the values that are allowed on the type, as specified in the **AnyNonPackageExecutablePropertyType** type. Hence, the formal type declarations of the

Property element and the **PropertyExpression** elements are replaced in this anonymous XSD fragment with a reference to [TaskExePropertyNameEnum](#) simple type. The **Name** attribute of the **Property** element MUST be restricted to the values that are shown as valid in the XSD fragment that is contained in the **TaskExePropertyNameEnum** section.

For more information about the elements, attributes, and enumeration values in the following XSD fragment, see section 2.5.

```

<xs:complexType>
  <xs:sequence>
    <xs:element name="ForEachEnumerator"
      type="DTS:ForEachEnumeratorType"
      minOccurs="0" maxOccurs="0"/>
    <xs:element name="Property"
      maxOccurs="unbounded">
      <xs:complexType>
        <xs:complexContent>
          <xs:extension base="DTS:PropertyElementBaseType">
            <xs:attribute name="Name"
              type="DTS:TaskExePropertyNameEnum"
              use="required"/>
          </xs:extension>
        </xs:complexContent>
      </xs:complexType>
    </xs:element>
    <xs:element name="Variable" type="DTS:VariableType"
      minOccurs="0" maxOccurs="unbounded"/>
    <xs:element name="LoggingOptions" type="DTS:LoggingOptionsType"/>
    <xs:element name="PropertyExpression"
      type="DTS:PropertyExpressionElementType"
      minOccurs="0" maxOccurs="unbounded"/>
    <xs:element name="PrecedenceConstraint"
      type="DTS:PrecedenceConstraintType"
      minOccurs="0" maxOccurs="unbounded"/>
    <xs:element name="ForEachVariableMapping"
      type="DTS:ForEachVariableMappingType"
      minOccurs="0" maxOccurs="0"/>
    <xs:element name="EventHandler" type="DTS:EventHandlerType"
      minOccurs="0" maxOccurs="unbounded"/>
    <xs:element name="ObjectData">
      <xs:complexType>
        <xs:choice>
          <xs:element name="WMIDRTaskData"
            type="DTS:WMIDRTaskDataObjectDataType"
            form="unqualified"/>
        </xs:choice>
      </xs:complexType>
    </xs:element>
  </xs:sequence>
  <xs:attribute name="ExecutableType" use="required">
    <xs:simpleType>
      <xs:restriction base="xs:string">
        <xs:enumeration
          value="Microsoft.SqlServer.Dts.Tasks.WmiDataReaderTask.WmiDataReaderTask,
            Microsoft.SqlServer.WMIDRTask, Version=10.0.0.0, Culture=neutral,
            PublicKeyToken=89845dcd8080cc91"/>
        <xs:enumeration value="STOCK:WmiDataReaderTask"/>
      </xs:restriction>
    </xs:simpleType>
  </xs:attribute>
  <xs:attribute name="ThreadHint" use="optional" type="xs:int"/>
</xs:complexType>

```

2.6.3.24 ExecutableType Instance for WMI Event Watcher Task

Windows Management Instrumentation (WMI) Event Watcher Task watches for a WMI event by using a WMI Query Language (WQL) event query to specify events of interest. An executable is a WMI Event Watcher Task executable if the **ExecutableType** attribute value is one of the following:

- Microsoft.SqlServer.Dts.Tasks.WmiEventWatcherTask.WmiEventWatcherTask, Microsoft.SqlServer.WMI EWTask, Version=10.0.0.0, Culture=neutral, PublicKeyToken=89845dcd8080cc91
- STOCK:WmiEventWatcherTask

The WMI Event Watcher Task executable is formally defined to be of type [AnyNonPackageExecutableType](#). However, the following XSD fragment, which is expressed as an anonymous complex type declaration, places further restrictions on the type than the restrictions that are declared in the **AnyNonPackageExecutableType** type declaration. An [Executable](#) element with the **ExecutableType** attribute value equal to "Microsoft.SqlServer.Dts.Tasks.WmiEventWatcherTask.WmiEventWatcherTask, Microsoft.SqlServer.WMI EWTask, Version=10.0.0.0, Culture=neutral, PublicKeyToken=89845dcd8080cc91" or "STOCK:WmiEventWatcherTask" MUST follow the anonymous type declaration that is contained in this section.

Note the following differences between this anonymous complex type declaration and the full definition of the complex type for the **AnyNonPackageExecutableNameEnum** type:

- This **Executable** element MUST NOT contain an **Executable** element.
- This **Executable** element MUST NOT contain a **ForEachEnumerator** element.
- This **Executable** element MUST NOT contain a **ForEachVariableMapping** element.
- In the **AnyNonPackageExecutableType** type, the type of the **ObjectData** element is given as [ExecutableObjectDataType](#). The **ExecutableObjectDataType** type definition contains an **xs:choice** XSD Schema element. However, not all of the choices that are allowed in the **xs:choice** XSD Schema element are available for the WMI Event Watcher Task executable. For this **Executable** element, the **ObjectData** element MUST contain the **WMI EWTaskData** element of type [WMI EWTaskDataObjectDataType](#).
- The allowed values for the **Name** attribute of the **Property** element are a restricted subset of the values that are allowed on the type, as specified in the **AnyNonPackageExecutablePropertyType** type. Hence, the formal type declarations of the **Property** element and the **PropertyExpression** elements are replaced in this anonymous XSD fragment with a reference to the [TaskExePropertyNameEnum](#) simple type. The **Name** attribute of the **Property** element MUST be restricted to the values that are shown as valid in the XSD fragment that is contained in the **TaskExePropertyNameEnum** section.

For more information about the elements, attributes, and enumeration values in the following XSD fragment, see section 2.5.

```
<xs:complexType>
  <xs:sequence>
    <xs:element name="ForEachEnumerator"
      type="DTS:ForEachEnumeratorType"
      minOccurs="0" maxOccurs="0"/>
    <xs:element name="Property"
      maxOccurs="unbounded">
      <xs:complexType>
        <xs:complexContent>
          <xs:extension base="DTS:PropertyElementBaseType">
            <xs:attribute name="Name"
              type="DTS:TaskExePropertyNameEnum"
              />
          </xs:extension>
        </xs:complexContent>
      </xs:complexType>
    </xs:element>
  </xs:sequence>
</xs:complexType>
```



```

        use="required"/>
    </xs:extension>
</xs:complexContent>
</xs:complexType>
</xs:element>
<xs:element name="Variable" type="DTS:VariableType"
    minOccurs="0" maxOccurs="unbounded"/>
<xs:element name="LoggingOptions" type="DTS:LoggingOptionsType"/>
<xs:element name="PropertyExpression"
    type="DTS:PropertyExpressionElementType"
    minOccurs="0" maxOccurs="unbounded"/>
<xs:element name="PrecedenceConstraint"
    type="DTS:PrecedenceConstraintType"
    minOccurs="0" maxOccurs="unbounded"/>
<xs:element name="ForEachVariableMapping"
    type="DTS:ForEachVariableMappingType"
    minOccurs="0" maxOccurs="0"/>
<xs:element name="EventHandler" type="DTS:EventHandlerType"
    minOccurs="0" maxOccurs="unbounded"/>
<xs:element name="ObjectData">
    <xs:complexType>
        <xs:choice>
            <xs:element
                name="WMIEWTaskData" type="DTS:WMIEWTaskDataObjectDataType"
                form="unqualified"/>
        </xs:choice>
    </xs:complexType>
</xs:element>
</xs:sequence>
<xs:attribute name="ExecutableType" use="required">
    <xs:simpleType>
        <xs:restriction base="xs:string">
            <xs:enumeration
                value="Microsoft.SqlServer.Dts.Tasks.WmiEventWatcherTask.WmiEventWatcherTask,
                Microsoft.SqlServer.WMIEWTask, Version=10.0.0.0, Culture=neutral,
                PublicKeyToken=89845dcd8080cc91"/>
            <xs:enumeration value="STOCK:WmiEventWatcherTask"/>
        </xs:restriction>
    </xs:simpleType>
</xs:attribute>
<xs:attribute name="ThreadHint" use="optional" type="xs:int"/>
</xs:complexType>

```

2.6.3.25 ExecutableType Instance for XML Task

XML Task is used to work with XML data. By using this task, a package can retrieve XML documents; apply operations to the documents by using Extensible Stylesheet Language Transformations (XSLT) style sheets and XPath expressions; merge multiple documents; or validate, compare, and save the updated documents to files and variables. An executable is an XML Task executable if the **ExecutableType** attribute value is one of the following:

- Microsoft.SqlServer.Dts.Tasks.XMLTask.XMLTask, Microsoft.SqlServer.XMLTask, Version=10.0.0.0, Culture=neutral, PublicKeyToken=89845dcd8080cc91
- STOCK: XMLTask

The XML Task executable is formally defined to be of type [AnyNonPackageExecutableType](#). However, the following XSD fragment, which is expressed as an anonymous complex type declaration, places further restrictions on the type than the restrictions that are declared in the **AnyNonPackageExecutableType** type declaration. An [Executable](#) element with the **ExecutableType** attribute value equal to "Microsoft.SqlServer.Dts.Tasks.XMLTask.XMLTask, Microsoft.SqlServer.XMLTask, Version=10.0.0.0, Culture=neutral, PublicKeyToken=89845dcd8080cc91" or "STOCK: XMLTask" MUST follow the anonymous type declaration that is contained in this section.

Note the following differences between this anonymous complex type declaration and the full definition of the complex type for the **AnyNonPackageExecutableType** type:

- This **Executable** element MUST NOT contain an **Executable** element.
- This **Executable** element MUST NOT contain a **ForEachEnumerator** element.
- This **Executable** element MUST NOT contain a **ForEachVariableMapping** element.
- In the **AnyNonPackageExecutableType** type, the type of the **ObjectData** element is given as [ExecutableObjectDataType](#). The **ExecutableObjectDataType** type definition contains an **xs:choice** XSD Schema element. However, not all of the choices that are allowed in the **xs:choice** XSD Schema element are available for the XML Task executable. For this **Executable** element, the **ObjectData** element MUST contain the **XMLTaskData** element of type [XMLTaskDataObjectDataType](#).
- The allowed values for the **Name** attribute of the **Property** element are a restricted subset of the values that are allowed on the type, as specified in the **AnyNonPackageExecutablePropertyNameEnum** type. Hence, the formal type declarations of the **Property** element and the **PropertyExpression** elements are replaced in this anonymous XSD fragment with a reference to the [TaskExePropertyNameEnum](#) simple type. The **Name** attribute of the **Property** element MUST be restricted to the values that are shown as valid in the XSD fragment that is contained in the **TaskExePropertyNameEnum** section.

For more information about the elements, attributes, and enumeration values in the following XSD fragment, see section 2.5.

```
<xs:complexType>
  <xs:sequence>
    <xs:element name="ForEachEnumerator"
      type="DTS:ForEachEnumeratorType"
      minOccurs="0" maxOccurs="0"/>
    <xs:element name="Property"
      maxOccurs="unbounded">
      <xs:complexType>
        <xs:complexContent>
          <xs:extension base="DTS:PropertyElementBaseType">
            <xs:attribute name="Name"
              type="DTS:TaskExePropertyNameEnum"
              use="required"/>
          </xs:extension>
        </xs:complexContent>
      </xs:complexType>
    </xs:element>
    <xs:element name="Variable" type="DTS:VariableType"
      minOccurs="0" maxOccurs="unbounded"/>
    <xs:element name="LoggingOptions" type="DTS:LoggingOptionsType"/>
    <xs:element name="PropertyExpression"
      type="DTS:PropertyExpressionElementType"
      minOccurs="0" maxOccurs="unbounded"/>
    <xs:element name="PrecedenceConstraint"
      type="DTS:PrecedenceConstraintType"
      minOccurs="0" maxOccurs="unbounded"/>
    <xs:element name="ForEachVariableMapping"
      type="DTS:ForEachVariableMappingType"
      minOccurs="0" maxOccurs="0"/>
    <xs:element name="EventHandler" type="DTS:EventHandlerType"
      minOccurs="0" maxOccurs="unbounded"/>
    <xs:element name="ObjectData">
      <xs:complexType>
        <xs:choice>
          <xs:element name="XMLTaskData"
            type="DTS:XMLTaskDataObjectDataType"
            form="unqualified"/>
        </xs:choice>
      </xs:complexType>
    </xs:element>
  </xs:sequence>
</xs:complexType>
```

```

        </xs:complexType>
    </xs:element>
</xs:sequence>
<xs:attribute name="ExecutableType" use="required">
    <xs:simpleType>
        <xs:restriction base="xs:string">
            <xs:enumeration
                value="Microsoft.SqlServer.Dts.Tasks.XMLTask.XMLTask,
                    Microsoft.SqlServer.XMLTask, Version=10.0.0.0, Culture=neutral,
                    PublicKeyToken=89845dcd8080cc91"/>
            <xs:enumeration value="STOCK:XMLTask"/>
        </xs:restriction>
    </xs:simpleType>
</xs:attribute>
<xs:attribute name="ThreadHint" use="optional" type="xs:int"/>
</xs:complexType>

```

2.6.4 Executable Maintenance Tasks

Executable maintenance task types are not a formal type within the XSD. They are a conceptual subdivision of the values for the **ExecutableType** attribute on the Executable element, as specified by the [AnyNonPackageExecutableType](#) type. The **Executable** elements that are specified in the following subsections MUST NOT contain additional executables nested within an instance of themselves.

2.6.4.1 ExecutableType Instance for Backup Task

Backup Task is used to add a backup task to a database maintenance plan. An executable is a Backup Task executable if the **ExecutableType** attribute value is "Microsoft.SqlServer.Management.DatabaseMaintenance.DbMaintenanceBackupTask, Microsoft.SqlServer.MaintenancePlanTasks, Version=10.0.0.0, Culture=neutral, PublicKeyToken=89845dcd8080cc91".

The Backup Task executable is formally defined to be of type [AnyNonPackageExecutableType](#). However, the following XSD fragment, which is expressed as an anonymous complex type declaration, places further restrictions on the type than the restrictions that are declared in the **AnyNonPackageExecutableType** type declaration. An [Executable](#) element with the **ExecutableType** attribute value equal to "Microsoft.SqlServer.Management.DatabaseMaintenance.DbMaintenanceBackupTask, Microsoft.SqlServer.MaintenancePlanTasks, Version=10.0.0.0, Culture=neutral, PublicKeyToken=89845dcd8080cc91" MUST follow the anonymous type declaration that is contained in this section.

Note the following differences between this anonymous complex type declaration and the full definition of the complex type for the **AnyNonPackageExecutableType** type:

- This **Executable** element MUST NOT contain an **Executable** element.
- This **Executable** element MUST NOT contain a **ForEachEnumerator** element.
- This **Executable** element MUST NOT contain a **ForEachVariableMapping** element.
- In the **AnyNonPackageExecutableType** type, the type of the **ObjectData** element is given as [ExecutableObjectDataType](#). The **ExecutableObjectDataType** type definition contains an **xs:choice** XSD Schema element. However, not all of the choices that are allowed in the **xs:choice** XSD Schema element are available for the Backup Task executable. For this **Executable** element, the **ObjectData** element MUST contain the [SqlTaskData](#) element that is specified in the [SQLTask](#) namespace. The **SqlTaskData** element declaration in the **SQLTask** namespace MUST be replaced by the declaration and type that is specified in this section. This instance of the **SqlTaskData** element MUST NOT contain elements except for the

SelectedDatabases element and the **BackupDestinationList** element. This instance of the **SqlTaskData** element MUST NOT contain attributes other than those that are specified in the [SqlTaskBaseAttributeGroup](#) attribute group, the [MaintenanceTaskBaseAttributeGroup](#) attribute group, the [BackupTaskAttributeGroup](#) attribute group, and the **DatabaseSelectionType** attribute.

- The allowed values for the **Name** attribute of the **Property** element are a restricted subset of the values that are allowed on the type, as specified in the **AnyNonPackageExecutablePropertyNameEnum** type. Hence, the formal type declarations of the **Property** element and the **PropertyExpression** elements are replaced in this anonymous XSD fragment with a reference to the [TaskExePropertyNameEnum](#) simple type. The **Name** attribute of the **Property** element MUST be restricted to the values that are shown as valid in the XSD fragment that is contained in that section.

For more information about the elements, attributes, and enumeration values in the following XSD fragment, see section 2.5.

```
<xs:complexType>
  <xs:sequence>
    <xs:element name="ForEachEnumerator"
      type="DTS:ForEachEnumeratorType"
      minOccurs="0" maxOccurs="0"/>
    <xs:element name="Property"
      maxOccurs="unbounded">
      <xs:complexType>
        <xs:complexContent>
          <xs:extension base="DTS:PropertyElementBaseType">
            <xs:attribute name="Name"
              type="DTS:TaskExePropertyNameEnum"
              use="required"/>
          </xs:extension>
        </xs:complexContent>
      </xs:complexType>
    </xs:element>
    <xs:element name="Variable" type="DTS:VariableType"
      minOccurs="0" maxOccurs="unbounded"/>
    <xs:element name="LoggingOptions" type="DTS:LoggingOptionsType"/>
    <xs:element name="PropertyExpression"
      type="DTS:PropertyExpressionElementType"
      minOccurs="0" maxOccurs="unbounded"/>
    <xs:element name="PrecedenceConstraint"
      type="DTS:PrecedenceConstraintType"
      minOccurs="0" maxOccurs="unbounded"/>
    <xs:element name="ForEachVariableMapping"
      type="DTS:ForEachVariableMappingType"
      minOccurs="0" maxOccurs="0"/>
    <xs:element name="EventHandler" type="DTS:EventHandlerType"
      minOccurs="0" maxOccurs="unbounded"/>
    <xs:element name="ObjectData">
      <xs:complexType>
        <xs:choice>
          <xs:element ref="SQLTask:SqlTaskData"/>
        </xs:choice>
      </xs:complexType>
    </xs:element>
  </xs:sequence>
  <xs:attribute name="ExecutableType" use="required">
    <xs:simpleType>
      <xs:restriction base="xs:string">
        <xs:enumeration
          value="Microsoft.SqlServer.Management.DatabaseMaintenance.DbMaintenanceBackupTask,
Microsoft.SqlServer.MaintenancePlanTasks, Version=10.0.0.0, Culture=neutral,
PublicKeyToken=89845dcd8080cc91"/>
      </xs:restriction>
    </xs:simpleType>
  </xs:attribute>
```

```

    <xs:attribute name="ThreadHint" use="optional" type="xs:int"/>
  </xs:complexType>

```

The preceding anonymous complex type definition requires that the declaration for the **SqlTaskData** element and its type, in the **SQLTask** namespace, be changed to the following.

```

<xs:element name="SqlTaskData"
  type="SQLTask:SqlTaskDataElementBackupTaskType"/>
<xs:complexType name="SqlTaskDataElementCheckIntegrityTaskType">
  <xs:sequence>
    <xs:element name="SelectedDatabases"
      type="SQLTask:SelectedDatabasesType"
      minOccurs="0" maxOccurs="unbounded"/>
    <xs:element name="BackupDestinationList"
      type="SQLTask:BackupDestinationListType"
      minOccurs="0" maxOccurs="unbounded"/>
  </xs:sequence>
  <xs:attributeGroup
    ref="SQLTask:SqlTaskBaseAttributeGroup"/>
  <xs:attributeGroup
    ref="SQLTask:MaintenanceTaskBaseAttributeGroup"/>
  <xs:attributeGroup
    ref="SQLTask:CheckIntegrityTaskAttributeGroup"/>
  <xs:attribute name="DatabaseSelectionType"
    type="SQLTask:SqlTaskDatabaseSelectionTypeEnum"/>
</xs:complexType>

```

2.6.4.2 ExecutableType Instance for Check Integrity Task

Check Integrity Task checks the allocation and structural integrity of all the objects in a database. An executable is a Check Integrity Task executable if the **ExecutableType** attribute value is "Microsoft.SqlServer.Management.DatabaseMaintenance.DbMaintenanceCheckIntegrityTask, Microsoft.SqlServer.MaintenancePlanTasks, Version=10.0.0.0, Culture=neutral, PublicKeyToken=89845dcd8080cc91".

The Check Integrity Task executable is formally defined to be of type [AnyNonPackageExecutableType](#). However, the following XSD fragment, which is expressed as an anonymous complex type declaration, places further restrictions on the type than the restrictions that are declared in the **AnyNonPackageExecutableNameEnum** type declaration. An [Executable](#) element with the **ExecutableType** attribute value equal to "Microsoft.SqlServer.Management.DatabaseMaintenance.DbMaintenanceCheckIntegrityTask, Microsoft.SqlServer.MaintenancePlanTasks, Version=10.0.0.0, Culture=neutral, PublicKeyToken=89845dcd8080cc91" MUST follow the anonymous type declaration that is contained in this section.

Note the following differences between this anonymous complex type declaration and the full definition of the complex type for the **AnyNonPackageExecutableType** type:

- This **Executable** element MUST NOT contain an **Executable** element.
- This **Executable** element MUST NOT contain a **ForEachEnumerator** element.
- This **Executable** element MUST NOT contain a **ForEachVariableMapping** element.
- In the **AnyNonPackageExecutableType** type, the type of the **ObjectData** element is given as [ExecutableObjectDataType](#). The **ExecutableObjectDataType** type definition contains an **xs:choice** XSD Schema element. However, not all of the choices that are allowed in the **xs:choice** XSD Schema element are available for the Check Integrity Task executable. For this **Executable** element, the **ObjectData** element MUST contain the [SqlTaskData](#) element that is specified in the [SQLTask](#) namespace. The **SqlTaskData** element declaration in the **SQLTask**

namespace MUST be replaced by the declaration and type that is specified in this section. This instance of the **SqlTaskData** element MUST NOT contain elements except for the **SelectedDatabases** element. This instance of the **SqlTaskData** element MUST NOT contain attributes other than those that are specified in the [SqlTaskBaseAttributeGroup](#) attribute group, the [MaintenanceTaskBaseAttributeGroup](#) attribute group, the [CheckIntegrityTaskAttributeGroup](#) attribute group, and the **DatabaseSelectionType** attribute.

- The allowed values for the **Name** attribute of the **Property** element are a restricted subset of the values that are allowed on the type, as specified in the **AnyNonPackageExecutablePropertyType** type. Hence, the formal type declarations of the **Property** element and the **PropertyExpression** elements are replaced in this anonymous XSD fragment with a reference to the [TaskExePropertyNameEnum](#) simple type. The **Name** attribute of the **Property** element MUST be restricted to the values that are shown as valid in the XSD fragment that is contained in the **TaskExePropertyNameEnum** section.

For more information about the elements, attributes, and enumeration values in the following XSD fragment, see section 2.5.

```
<xs:element name="MaintenanceCheckIntegrityExe">
  <xs:complexType>
    <xs:sequence>
      <xs:element name="ForEachEnumerator"
        type="DTS:ForEachEnumeratorType"
        minOccurs="0" maxOccurs="0"/>
      <xs:element name="Property"
        maxOccurs="unbounded">
        <xs:complexType>
          <xs:complexContent>
            <xs:extension base="DTS:PropertyElementBaseType">
              <xs:attribute name="Name"
                type="DTS:TaskExePropertyNameEnum"
                use="required"/>
            </xs:extension>
          </xs:complexContent>
        </xs:complexType>
      </xs:element>
      <xs:element name="Variable" type="DTS:VariableType"
        minOccurs="0" maxOccurs="unbounded"/>
      <xs:element name="LoggingOptions" type="DTS:LoggingOptionsType"/>
      <xs:element name="PropertyExpression"
        type="DTS:PropertyExpressionElementType"
        minOccurs="0" maxOccurs="unbounded"/>
      <xs:element name="PrecedenceConstraint"
        type="DTS:PrecedenceConstraintType"
        minOccurs="0" maxOccurs="unbounded"/>
      <xs:element name="ForEachVariableMapping"
        type="DTS:ForEachVariableMappingType"
        minOccurs="0" maxOccurs="0"/>
      <xs:element name="EventHandler" type="DTS:EventHandlerType"
        minOccurs="0" maxOccurs="unbounded"/>
      <xs:element name="ObjectData">
        <xs:complexType>
          <xs:choice>
            <xs:element ref="SQLTask:SqlTaskData"/>
          </xs:choice>
        </xs:complexType>
      </xs:element>
    </xs:sequence>
    <xs:attribute name="ExecutableType" use="required">
      <xs:simpleType>
        <xs:restriction base="xs:string">
          <xs:enumeration
            value="Microsoft.SqlServer.Management.DatabaseMaintenance.DbMaintenanceCheckIntegrityTask,
            Microsoft.SqlServer.MaintenancePlanTasks, Version=10.0.0.0, Culture=neutral,
            PublicKeyToken=89845dcd8080cc91"/>
        </xs:restriction>
      </xs:simpleType>
    </xs:attribute>
  </xs:complexType>
</xs:element>
```

```

    </xs:simpleType>
  </xs:attribute>
  <xs:attribute name="ThreadHint" use="optional" type="xs:int"/>
</xs:complexType>

```

The preceding anonymous complex type definition requires that the declaration for the **SqlTaskData** element and its type, in the **SQLTask** namespace, be changed to the following.

```

<xs:element name="SqlTaskData"
  type="SQLTask:SqlTaskDataElementCheckIntegrityTaskType"/>
<xs:complexType name="SqlTaskDataElementCheckIntegrityTaskType">
  <xs:sequence>
    <xs:element name="SelectedDatabases"
      type="SQLTask:SelectedDatabasesType"
      minOccurs="0" maxOccurs="unbounded"/>
  </xs:sequence>
  <xs:attributeGroup
    ref="SQLTask:SqlTaskBaseAttributeGroup"/>
  <xs:attributeGroup
    ref="SQLTask:MaintenanceTaskBaseAttributeGroup"/>
  <xs:attributeGroup
    ref="SQLTask:CheckIntegrityTaskAttributeGroup"/>
  <xs:attribute name="DatabaseSelectionType"
    type="SQLTask:SqlTaskDatabaseSelectionTypeEnum"/>
</xs:complexType>

```

2.6.4.3 ExecutableType Instance for Execute SQL Agent Job Task

Execute SQL Agent Job Task runs SQL Server Agent jobs. SQL Server Agent is a Windows service that runs jobs that have been defined in an instance of Microsoft SQL Server. An executable is an Execute SQL Agent Job Task executable if the **ExecutableType** attribute value is "Microsoft.SqlServer.Management.DatabaseMaintenance.DbMaintenanceExecuteAgentJobTask, Microsoft.SqlServer.MaintenancePlanTasks, Version=10.0.0.0, Culture=neutral, PublicKeyToken=89845dcd8080cc91".

The Execute SQL Agent Job Task executable is formally defined to be of type [AnyNonPackageExecutableType](#). However, the following XSD fragment, which is expressed as an anonymous complex type declaration, places further restrictions on the type than the restrictions that are declared in the **AnyNonPackageExecutableType** type declaration. An [Executable](#) element with the **ExecutableType** attribute value equal to "Microsoft.SqlServer.Management.DatabaseMaintenance.DbMaintenanceExecuteAgentJobTask, Microsoft.SqlServer.MaintenancePlanTasks, Version=10.0.0.0, Culture=neutral, PublicKeyToken=89845dcd8080cc91" MUST follow the anonymous type declaration that is contained in this section.

Note the following differences between this anonymous complex type declaration and the full definition of the complex type for the **AnyNonPackageExecutableType** type:

- This **Executable** element MUST NOT contain an **Executable** element.
- This **Executable** element MUST NOT contain a **ForEachEnumerator** element.
- This **Executable** element MUST NOT contain a **ForEachVariableMapping** element.
- In the **AnyNonPackageExecutableType** type, the type of the **ObjectData** element is given as [ExecutableObjectDataType](#). The **ExecutableObjectDataType** type definition contains an **xs:choice** XSD Schema element. However, not all of the choices that are allowed in the **xs:choice** XSD Schema element are available for the Execute SQL Agent Job Task executable. For this **Executable** element, the **ObjectData** element MUST contain the [SqlTaskData](#) element that is

specified in the [SQLTask](#) namespace. The **SqlTaskData** element declaration in the **SQLTask** namespace MUST be replaced by the declaration and type that is specified in this section. This instance of the **SqlTaskData** element MUST contain zero elements. This instance of the **SqlTaskData** element MUST NOT contain attributes other than those that are specified in the [SqlTaskBaseAttributeGroup](#) attribute group, the [MaintenanceTaskBaseAttributeGroup](#) attribute group, and the [AgentJobTaskAttributeGroup](#) attribute group.

- The allowed values for the **Name** attribute of the **Property** element are a restricted subset of the values that are allowed on the type, as specified in the **AnyNonPackageExecutablePropertyNameEnum** type. Hence, the formal type declarations of the **Property** element and the **PropertyExpression** elements are replaced in this anonymous XSD fragment with a reference to the [TaskExePropertyNameEnum](#) simple type. The **Name** attribute of the **Property** element MUST be restricted to the values that are shown as valid in the XSD fragment that is contained in the **TaskExePropertyNameEnum** section.

For more information about the elements, attributes, and enumeration values in the following XSD fragment, see section 2.5.

```
<xs:complexType>
  <xs:sequence>
    <xs:element name="ForEachEnumerator"
      type="DTS:ForEachEnumeratorType"
      minOccurs="0" maxOccurs="0"/>
    <xs:element name="Property"
      maxOccurs="unbounded">
      <xs:complexType>
        <xs:complexContent>
          <xs:extension base="DTS:PropertyElementBaseType">
            <xs:attribute name="Name"
              type="DTS:TaskExePropertyNameEnum"
              use="required"/>
          </xs:extension>
        </xs:complexContent>
      </xs:complexType>
    </xs:element>
    <xs:element name="Variable" type="DTS:VariableType"
      minOccurs="0" maxOccurs="unbounded"/>
    <xs:element name="LoggingOptions" type="DTS:LoggingOptionsType"/>
    <xs:element name="PropertyExpression"
      type="DTS:PropertyExpressionElementType"
      minOccurs="0" maxOccurs="unbounded"/>
    <xs:element name="PrecedenceConstraint"
      type="DTS:PrecedenceConstraintType"
      minOccurs="0" maxOccurs="unbounded"/>
    <xs:element name="ForEachVariableMapping"
      type="DTS:ForEachVariableMappingType"
      minOccurs="0" maxOccurs="0"/>
    <xs:element name="EventHandler" type="DTS:EventHandlerType"
      minOccurs="0" maxOccurs="unbounded"/>
    <xs:element name="ObjectData">
      <xs:complexType>
        <xs:choice>
          <xs:element ref="SQLTask:SqlTaskData"/>
        </xs:choice>
      </xs:complexType>
    </xs:element>
  </xs:sequence>
  <xs:attribute name="ExecutableType" use="required">
    <xs:simpleType>
      <xs:restriction base="xs:string">
        <xs:enumeration
          value="Microsoft.SqlServer.Management.DatabaseMaintenance.DbMaintenanceExecuteAgentJobTask,
            Microsoft.SqlServer.MaintenancePlanTasks, Version=10.0.0.0, Culture=neutral,
            PublicKeyToken=89845dcd8080cc91"/>
      </xs:restriction>
    </xs:simpleType>
  </xs:attribute>
</xs:complexType>
```



```

    </xs:attribute>
    <xs:attribute name="ThreadHint" use="optional" type="xs:int"/>
  </xs:complexType>

```

The preceding anonymous complex type definition requires that the declaration for the **SqlTaskData** element and its type, in the **SQLTask** namespace, be changed to the following.

```

<xs:element name="SqlTaskData"
            type="SQLTask:SqlTaskDataElementAgentJobTaskType"/>
<xs:complexType name="SqlTaskDataElementAgentJobTaskType">
  <xs:sequence/>
  <xs:attributeGroup
    ref="SQLTask:SqlTaskBaseAttributeGroup"/>
  <xs:attributeGroup
    ref="SQLTask:MaintenanceTaskBaseAttributeGroup"/>
  <xs:attributeGroup
    ref="SQLTask:AgentJobTaskAttributeGroup"/>
</xs:complexType>

```

2.6.4.4 ExecutableType Instance for History Cleanup Task

History Cleanup Task deletes history entries from a database. An executable is a History Cleanup Task executable if the **ExecutableType** attribute value is "Microsoft.SqlServer.Management.DatabaseMaintenance.DbMaintenanceHistoryCleanupTask, Microsoft.SqlServer.MaintenancePlanTasks, Version=10.0.0.0, Culture=neutral, PublicKeyToken=89845dcd8080cc91".

The History Cleanup Task executable is formally defined to be of type [AnyNonPackageExecutableType](#). However, the following XSD fragment, which is expressed as an anonymous complex type declaration, places further restrictions on the type than the restrictions that are declared in the **AnyNonPackageExecutableType** type declaration. An [Executable](#) element with the **ExecutableType** attribute value equal to "Microsoft.SqlServer.Management.DatabaseMaintenance.DbMaintenanceHistoryCleanupTask, Microsoft.SqlServer.MaintenancePlanTasks, Version=10.0.0.0, Culture=neutral, PublicKeyToken=89845dcd8080cc91" MUST follow the anonymous type declaration that is contained in this section.

Note the following differences between this anonymous complex type declaration and the full definition of the complex type for the **AnyNonPackageExecutableType** type:

- This **Executable** element MUST NOT contain an **Executable** element.
- This **Executable** element MUST NOT contain a **ForEachEnumerator** element.
- This **Executable** element MUST NOT contain a **ForEachVariableMapping** element.
- In the **AnyNonPackageExecutableType** type, the type of the **ObjectData** element is given as [ExecutableObjectDataType](#). The **ExecutableObjectDataType** type definition contains an **xs:choice** XSD Schema element. However, not all of the choices that are allowed in the **xs:choice** XSD Schema element are available for the History Cleanup Task executable. For this **Executable** element, the **ObjectData** element MUST contain the [SqlTaskData](#) element that is specified in the [SQLTask](#) namespace. The **SqlTaskData** element declaration in the [SQLTask](#) namespace MUST be replaced by the declaration and type that is specified in this section. This instance of the **SqlTaskData** element MUST contain zero elements. This instance of the **SqlTaskData** element MUST NOT contain attributes other than those that are specified in the [SqlTaskBaseAttributeGroup](#) attribute group, the [MaintenanceTaskBaseAttributeGroup](#) attribute group, the [HistoryCleanupTaskAttributeGroup](#) attribute group, the **RemoveOlderThan** attribute, and the **TimeUnitsType** attribute.

- The allowed values for the **Name** attribute of the **Property** element are a restricted subset of the values that are allowed on the type, as specified in the **AnyNonPackageExecutablePropertyNameEnum** type. Hence, the formal type declarations of the **Property** element and the **PropertyExpression** elements are replaced in this anonymous XSD fragment with a reference to the [TaskExePropertyNameEnum](#) simple type. The **Name** attribute of the **Property** element MUST be restricted to the values that are shown as valid in the XSD fragment that is contained in the **TaskExePropertyNameEnum** section.

For more information about the elements, attributes, and enumeration values in the following XSD fragment, see section 2.5.

```

<xs:complexType>
  <xs:sequence>
    <xs:element name="ForEachEnumerator"
      type="DTS:ForEachEnumeratorType"
      minOccurs="0" maxOccurs="0"/>
    <xs:element name="Property"
      maxOccurs="unbounded">
      <xs:complexType>
        <xs:complexContent>
          <xs:extension base="DTS:PropertyElementBaseType">
            <xs:attribute name="Name"
              type="DTS:TaskExePropertyNameEnum"
              use="required"/>
          </xs:extension>
        </xs:complexContent>
      </xs:complexType>
    </xs:element>
    <xs:element name="Variable" type="DTS:VariableType"
      minOccurs="0" maxOccurs="unbounded"/>
    <xs:element name="LoggingOptions" type="DTS:LoggingOptionsType"/>
    <xs:element name="PropertyExpression"
      type="DTS:PropertyExpressionElementType"
      minOccurs="0" maxOccurs="unbounded"/>
    <xs:element name="PrecedenceConstraint"
      type="DTS:PrecedenceConstraintType"
      minOccurs="0" maxOccurs="unbounded"/>
    <xs:element name="ForEachVariableMapping"
      type="DTS:ForEachVariableMappingType"
      minOccurs="0" maxOccurs="0"/>
    <xs:element name="EventHandler" type="DTS:EventHandlerType"
      minOccurs="0" maxOccurs="unbounded"/>
    <xs:element name="ObjectData">
      <xs:complexType>
        <xs:choice>
          <xs:element ref="SQLTask:SqlTaskData"/>
        </xs:choice>
      </xs:complexType>
    </xs:element>
  </xs:sequence>
  <xs:attribute name="ExecutableType" use="required">
    <xs:simpleType>
      <xs:restriction base="xs:string">
        <xs:enumeration
          value="Microsoft.SqlServer.Management.DatabaseMaintenance.DbMaintenanceHistoryCleanupTask,
          Microsoft.SqlServer.MaintenancePlanTasks, Version=10.0.0.0, Culture=neutral,
          PublicKeyToken=89845dcd8080cc91"/>
      </xs:restriction>
    </xs:simpleType>
  </xs:attribute>
  <xs:attribute name="ThreadHint" use="optional" type="xs:int"/>
</xs:complexType>

```

The preceding anonymous complex type definition requires that the declaration for the **SqlTaskData** element and its type, in the **SQLTask** namespace, be changed to the following.

```

<xs:element name="SqlTaskData"
            type="SQLTask:SqlTaskDataElementHistoryCleanupTaskType"/>
<xs:complexType name="SqlTaskDataElementHistoryCleanupTaskType">
  <xs:sequence/>
  <xs:attributeGroup
    ref="SQLTask:SqlTaskBaseAttributeGroup"/>
  <xs:attributeGroup
    ref="SQLTask:MaintenanceTaskBaseAttributeGroup"/>
  <xs:attributeGroup
    ref="SQLTask:HistoryCleanupTaskAttributeGroup"/>
  <xs:attribute name="RemoveOlderThan" type="xs:int"/>
  <xs:attribute name="TimeUnitsType"
    type="SQLTask:SqlTaskTimeUnitsTypeEnum"/>
</xs:complexType>

```

2.6.4.5 ExecutableType Instance for Maintenance File Cleanup Task

Maintenance File Cleanup Task removes database maintenance files according to user-specified logic. An executable is a Maintenance File Cleanup Task executable if the **ExecutableType** attribute value is "Microsoft.SqlServer.Management.DatabaseMaintenance.DbMaintenanceFileCleanupTask, Microsoft.SqlServer.MaintenancePlanTasks, Version=10.0.0.0, Culture=neutral, PublicKeyToken=89845dcd8080cc91".

The Maintenance File Cleanup Task executable is formally defined to be of type [AnyNonPackageExecutableType](#). However, the following XSD fragment, which is expressed as an anonymous complex type declaration, places further restrictions on the type than the restrictions that are declared in the **AnyNonPackageExecutableType** type declaration. An [Executable](#) element with the **ExecutableType** attribute value equal to "Microsoft.SqlServer.Management.DatabaseMaintenance.DbMaintenanceFileCleanupTask, Microsoft.SqlServer.MaintenancePlanTasks, Version=10.0.0.0, Culture=neutral, PublicKeyToken=89845dcd8080cc91" MUST follow the anonymous type declaration that is contained in this section.

Note the following differences between this anonymous complex type declaration and the full definition of the complex type for the **AnyNonPackageExecutableType** type:

- This **Executable** element MUST NOT contain an **Executable** element.
- This **Executable** element MUST NOT contain a **ForEachEnumerator** element.
- This **Executable** element MUST NOT contain a **ForEachVariableMapping** element.
- In the **AnyNonPackageExecutableType** type, the type of the **ObjectData** element is given as [ExecutableObjectDataType](#). The **ExecutableObjectDataType** type definition contains an **xs:choice** XSD Schema element. However, not all of the choices that are allowed in the **xs:choice** XSD Schema element are available for the Maintenance File Cleanup Task executable. For this **Executable** element, the **ObjectData** element MUST contain the [SqlTaskData](#) element that is specified in the [SQLTask](#) namespace. The **SqlTaskData** element declaration in the **SQLTask** namespace MUST be replaced by the declaration and type that is specified in this section. This instance of the **SqlTaskData** element MUST contain zero elements. This instance of the **SqlTaskData** element MUST NOT contain attributes other than those that are specified in the [SqlTaskBaseAttributeGroup](#) attribute group, the [MaintenanceTaskBaseAttributeGroup](#) attribute group, the [MaintenanceFileCleanupTaskAttributeGroup](#) attribute group, the **RemoveOlderThan** attribute, and the **TimeUnitsType** attribute.
- The allowed values for the **Name** attribute of the **Property** element are a restricted subset of the values that are allowed on the type, as specified in the **AnyNonPackageExecutablePropertyNameEnum** type. Hence, the formal type declarations of the **Property** element and the **PropertyExpression** elements are replaced in this anonymous XSD fragment with a reference to the [TaskExePropertyNameEnum](#) simple type. The **Name**

attribute of the **Property** element MUST be restricted to the values that are shown as valid in the XSD fragment that is contained in the **TaskExePropertyNameEnum** section.

For more information about the elements, attributes, and enumeration values in the following XSD fragment, see section 2.5.

```
<xs:complexType>
  <xs:sequence>
    <xs:element name="ForEachEnumerator"
      type="DTS:ForEachEnumeratorType"
      minOccurs="0" maxOccurs="0"/>
    <xs:element name="Property"
      maxOccurs="unbounded">
      <xs:complexType>
        <xs:complexContent>
          <xs:extension base="DTS:PropertyElementBaseType">
            <xs:attribute name="Name"
              type="DTS:TaskExePropertyNameEnum"
              use="required"/>
          </xs:extension>
        </xs:complexContent>
      </xs:complexType>
    </xs:element>
    <xs:element name="Variable" type="DTS:VariableType"
      minOccurs="0" maxOccurs="unbounded"/>
    <xs:element name="LoggingOptions" type="DTS:LoggingOptionsType"/>
    <xs:element name="PropertyExpression"
      type="DTS:PropertyExpressionElementType"
      minOccurs="0" maxOccurs="unbounded"/>
    <xs:element name="PrecedenceConstraint"
      type="DTS:PrecedenceConstraintType"
      minOccurs="0" maxOccurs="unbounded"/>
    <xs:element name="ForEachVariableMapping"
      type="DTS:ForEachVariableMappingType"
      minOccurs="0" maxOccurs="0"/>
    <xs:element name="EventHandler" type="DTS:EventHandlerType"
      minOccurs="0" maxOccurs="unbounded"/>
    <xs:element name="ObjectData">
      <xs:complexType>
        <xs:choice>
          <xs:element ref="SQLTask:SqlTaskData"/>
        </xs:choice>
      </xs:complexType>
    </xs:element>
  </xs:sequence>
  <xs:attribute name="ExecutableType" use="required">
    <xs:simpleType>
      <xs:restriction base="xs:string">
        <xs:enumeration
          value="Microsoft.SqlServer.Management.DatabaseMaintenance.DbMaintenanceFileCleanupTask,
Microsoft.SqlServer.MaintenancePlanTasks, Version=10.0.0.0, Culture=neutral,
PublicKeyToken=89845dcd8080cc91"/>
      </xs:restriction>
    </xs:simpleType>
  </xs:attribute>
  <xs:attribute name="ThreadHint" use="optional" type="xs:int"/>
</xs:complexType>
```

The preceding anonymous complex type definition requires that the declaration for the **SqlTaskData** element and its type, in the **SQLTask** namespace, be changed to the following.

```
<xs:element name="SqlTaskData"
  type="SQLTask:SqlTaskDataElementMaintenanceFileCleanupTaskType"/>
<xs:complexType
  name="SqlTaskDataElementMaintenanceFileCleanupTaskType">
  <xs:sequence/>
```

```

<xs:attributeGroup
  ref="SQLTask:SqlTaskBaseAttributeGroup"/>
<xs:attributeGroup
  ref="SQLTask:MaintenanceTaskBaseAttributeGroup"/>
<xs:attributeGroup
  ref="SQLTask:MaintenanceFileCleanupTaskAttributeGroup"/>
<xs:attribute name="RemoveOlderThan" type="xs:int"/>
<xs:attribute name="TimeUnitsType"
  type="SQLTask:SqlTaskTimeUnitsTypeEnum"/>
</xs:complexType>

```

2.6.4.6 ExecutableType Instance for Notify Operator Task

Notify Operator Task sends electronic notification messages to a list of SQL Server operators. An executable is a Notify Operator Task executable if the **ExecutableType** attribute value is "Microsoft.SqlServer.Management.DatabaseMaintenance.DbMaintenanceNotifyOperatorTask, Microsoft.SqlServer.MaintenancePlanTasks, Version=10.0.0.0, Culture=neutral, PublicKeyToken=89845dcd8080cc91".

The Notify Operator Task executable is formally defined to be of type [AnyNonPackageExecutableType](#). However, the following XSD fragment, which is expressed as an anonymous complex type declaration, places further restrictions on the type than the restrictions that are declared in the **AnyNonPackageExecutableType** type declaration. An [Executable](#) element with the **ExecutableType** attribute value equal to "Microsoft.SqlServer.Management.DatabaseMaintenance.DbMaintenanceNotifyOperatorTask, Microsoft.SqlServer.MaintenancePlanTasks, Version=10.0.0.0, Culture=neutral, PublicKeyToken=89845dcd8080cc91" MUST follow the anonymous type declaration that is contained in this section.

Note the following differences between this anonymous complex type declaration and the full definition of the complex type for the **AnyNonPackageExecutableType** type:

- This **Executable** element MUST NOT contain an **Executable** element.
- This **Executable** element MUST NOT contain a **ForEachEnumerator** element.
- This **Executable** element MUST NOT contain a **ForEachVariableMapping** element.
- In the **AnyNonPackageExecutableType** type, the type of the **ObjectData** element is given as [ExecutableObjectDataType](#). The **ExecutableObjectDataType** type definition contains an **xs:choice** XSD Schema element. However, not all of the choices that are allowed in the **xs:choice** XSD Schema element are available for the Notify Operator Task executable. For this **Executable** element, the **ObjectData** element MUST contain the [SqlTaskData](#) element that is specified in the [SQLTask](#) namespace. The **SqlTaskData** element declaration in the **SQLTask** namespace MUST be replaced by the declaration and type that is specified in this section. This instance of the **SqlTaskData** element MUST NOT contain elements except for the **NotifyOperator** element. This instance of the **SqlTaskData** element MUST NOT contain attributes other than those that are specified in the [SqlTaskBaseAttributeGroup](#) attribute group, the [MaintenanceTaskBaseAttributeGroup](#) attribute group, and the [NotifyOperatorTaskAttributeGroup](#) attribute group.
- The allowed values for the **Name** attribute of the **Property** element are a restricted subset of the values that are allowed on the type, as specified in the **AnyNonPackageExecutablePropertyNameEnum** type. Hence, the formal type declarations of the **Property** element and the **PropertyExpression** elements are replaced in this anonymous XSD fragment with a reference to the [TaskExePropertyNameEnum](#) simple type. The **Name** attribute of the **Property** element MUST be restricted to the values that are shown as valid in the XSD fragment that is contained in the **TaskExePropertyNameEnum** section.

For more information about the elements, attributes, and enumeration values in the following XSD fragment, see section 2.5.

```

<xs:complexType>
  <xs:sequence>
    <xs:element name="ForEachEnumerator"
      type="DTS:ForEachEnumeratorType"
      minOccurs="0" maxOccurs="0"/>
    <xs:element name="Property"
      maxOccurs="unbounded">
      <xs:complexType>
        <xs:complexContent>
          <xs:extension base="DTS:PropertyElementBaseType">
            <xs:attribute name="Name"
              type="DTS:TaskExePropertyNameEnum"
              use="required"/>
          </xs:extension>
        </xs:complexContent>
      </xs:complexType>
    </xs:element>
    <xs:element name="Variable" type="DTS:VariableType"
      minOccurs="0" maxOccurs="unbounded"/>
    <xs:element name="LoggingOptions" type="DTS:LoggingOptionsType"/>
    <xs:element name="PropertyExpression"
      type="DTS:PropertyExpressionElementType"
      minOccurs="0" maxOccurs="unbounded"/>
    <xs:element name="PrecedenceConstraint"
      type="DTS:PrecedenceConstraintType"
      minOccurs="0" maxOccurs="unbounded"/>
    <xs:element name="ForEachVariableMapping"
      type="DTS:ForEachVariableMappingType"
      minOccurs="0" maxOccurs="0"/>
    <xs:element name="EventHandler" type="DTS:EventHandlerType"
      minOccurs="0" maxOccurs="unbounded"/>
    <xs:element name="ObjectData">
      <xs:complexType>
        <xs:choice>
          <xs:element ref="SQLTask:SqlTaskData"/>
        </xs:choice>
      </xs:complexType>
    </xs:element>
  </xs:sequence>
  <xs:attribute name="ExecutableType" use="required">
    <xs:simpleType>
      <xs:restriction base="xs:string">
        <xs:enumeration
          value="Microsoft.SqlServer.Management.DatabaseMaintenance.DbMaintenanceNotifyOperatorTask,
          Microsoft.SqlServer.MaintenancePlanTasks, Version=10.0.0.0, Culture=neutral,
          PublicKeyToken=89845dcd8080cc91"/>
      </xs:restriction>
    </xs:simpleType>
  </xs:attribute>
  <xs:attribute name="ThreadHint" use="optional" type="xs:int"/>
</xs:complexType>

```

The preceding anonymous complex type definition requires that the declaration for the **SqlTaskData** element and its type, in the **SQLTask** namespace, be changed to the following.

```

<xs:element name="SqlTaskData"
  type="SQLTask:SqlTaskDataElementNotifyOperatorTaskType"/>
<xs:complexType name="SqlTaskDataElementNotifyOperatorTaskType">
  <xs:sequence>
    <xs:element name="OperatorNotifyList"
      type="SQLTask:OperatorNotifyListType"
      minOccurs="0" maxOccurs="unbounded"/>
  </xs:sequence>

```

```

<xs:attributeGroup
  ref="SQLTask:SqlTaskBaseAttributeGroup"/>
<xs:attributeGroup
  ref="SQLTask:MaintenanceTaskBaseAttributeGroup"/>
<xs:attributeGroup
  ref="SQLTask:NotifyOperatorTaskAttributeGroup"/>
</xs:complexType>

```

2.6.4.7 ExecutableType Instance for Rebuild Index Task

Rebuild Index Task rebuilds indexes in database tables and views. An executable is a Rebuild Index Task executable if the **ExecutableType** attribute value is "Microsoft.SqlServer.Management.DatabaseMaintenance.DbMaintenanceReindexTask, Microsoft.SqlServer.MaintenancePlanTasks, Version=10.0.0.0, Culture=neutral, PublicKeyToken=89845dcd8080cc91".

The Rebuild Index Task executable is formally defined to be of type [AnyNonPackageExecutableType](#). However, the following XSD fragment, which is expressed as an anonymous complex type declaration, places further restrictions on the type than the restrictions that are declared in the **AnyNonPackageExecutableType** type declaration. An [Executable](#) element with the **ExecutableType** attribute value equal to "Microsoft.SqlServer.Management.DatabaseMaintenance.DbMaintenanceReindexTask, Microsoft.SqlServer.MaintenancePlanTasks, Version=10.0.0.0, Culture=neutral, PublicKeyToken=89845dcd8080cc91" MUST follow the anonymous type declaration that is contained in this section.

Note the following differences between this anonymous complex type declaration and the full definition of the complex type for the **AnyNonPackageExecutableType** type:

- This **Executable** element MUST NOT contain an **Executable** element.
- This **Executable** element MUST NOT contain a **ForEachEnumerator** element.
- This **Executable** element MUST NOT contain a **ForEachVariableMapping** element.
- In the **AnyNonPackageExecutableType** type, the type of the **ObjectData** element is given as [ExecutableObjectDataType](#). The **ExecutableObjectDataType** type definition contains an **xs:choice** XSD Schema element. However, not all of the choices that are allowed in the **xs:choice** XSD Schema element are available for the Rebuild Index Task executable. For this **Executable** element, the **ObjectData** element MUST contain the [SqlTaskData](#) element that is specified in the [SQLTask](#) namespace. The **SqlTaskData** element declaration in the **SQLTask** namespace MUST be replaced by the declaration and type that is specified in this section. This instance of the **SqlTaskData** element MUST NOT contain elements except the **SelectedDatabases** element. This instance of the **SqlTaskData** element MUST NOT contain attributes other than those that are specified in the [SqlTaskBaseAttributeGroup](#) attribute group, the [MaintenanceTaskBaseAttributeGroup](#) attribute group, the [RebuildIndexTaskAttributeGroup](#) attribute group, and the **DatabaseSelectionType** attribute.
- The allowed values for the **Name** attribute of the **Property** element are a restricted subset of the values that are allowed on the type, as specified in the **AnyNonPackageExecutablePropertyNameEnum** type. Hence, the formal type declarations of the **Property** element and the **PropertyExpression** elements are replaced in this anonymous XSD fragment with a reference to the [TaskExePropertyNameEnum](#) simple type. The **Name** attribute of the **Property** element MUST be restricted to the values that are shown as valid in the XSD fragment that is contained in the **TaskExePropertyNameEnum** section.

For more information about the elements, attributes, and enumeration values in the following XSD fragment, see section 2.5.

```

<xs:complexType>
  <xs:sequence>
    <xs:element name="ForEachEnumerator"
      type="DTS:ForEachEnumeratorType"
      minOccurs="0" maxOccurs="0"/>
    <xs:element name="Property"
      maxOccurs="unbounded">
      <xs:complexType>
        <xs:complexContent>
          <xs:extension base="DTS:PropertyElementBaseType">
            <xs:attribute name="Name"
              type="DTS:TaskExePropertyNameEnum"
              use="required"/>
          </xs:extension>
        </xs:complexContent>
      </xs:complexType>
    </xs:element>
    <xs:element name="Variable" type="DTS:VariableType"
      minOccurs="0" maxOccurs="unbounded"/>
    <xs:element name="LoggingOptions" type="DTS:LoggingOptionsType"/>
    <xs:element name="PropertyExpression"
      type="DTS:PropertyExpressionElementType"
      minOccurs="0" maxOccurs="unbounded"/>
    <xs:element name="PrecedenceConstraint"
      type="DTS:PrecedenceConstraintType"
      minOccurs="0" maxOccurs="unbounded"/>
    <xs:element name="ForEachVariableMapping"
      type="DTS:ForEachVariableMappingType"
      minOccurs="0" maxOccurs="0"/>
    <xs:element name="EventHandler" type="DTS:EventHandlerType"
      minOccurs="0" maxOccurs="unbounded"/>
    <xs:element name="ObjectData">
      <xs:complexType>
        <xs:choice>
          <xs:element ref="SQLTask:SqlTaskData"/>
        </xs:choice>
      </xs:complexType>
    </xs:element>
  </xs:sequence>
  <xs:attribute name="ExecutableType" use="required">
    <xs:simpleType>
      <xs:restriction base="xs:string">
        <xs:enumeration
          value="Microsoft.SqlServer.Management.DatabaseMaintenance.DbMaintenanceReindexTask,
          Microsoft.SqlServer.MaintenancePlanTasks, Version=10.0.0.0, Culture=neutral,
          PublicKeyToken=89845dcd8080cc91"/>
      </xs:restriction>
    </xs:simpleType>
  </xs:attribute>
  <xs:attribute name="ThreadHint" use="optional" type="xs:int"/>
</xs:complexType>

```

The preceding anonymous complex type definition requires that the declaration for the **SqlTaskData** element and its type, in the **SQLTask** namespace, be changed to the following.

```

<xs:element name="SqlTaskData"
  type="SQLTask:SqlTaskDataElementRebuildIndexTaskType"/>
<xs:complexType name="SqlTaskDataElementRebuildIndexTaskType">
  <xs:sequence>
    <xs:element name="SelectedDatabases"
      type="SQLTask:SelectedDatabasesType"
      minOccurs="0" maxOccurs="unbounded"/>
  </xs:sequence>
  <xs:attributeGroup
    ref="SQLTask:SqlTaskBaseAttributeGroup"/>
  <xs:attributeGroup
    ref="SQLTask:MaintenanceTaskBaseAttributeGroup"/>

```

```

<xs:attributeGroup
  ref="SQLTask:RebuildIndexTaskAttributeGroup"/>
<xs:attribute name="DatabaseSelectionType"
  type="SQLTask:SqlTaskDatabaseSelectionTypeEnum"/>
</xs:complexType>

```

2.6.4.8 ExecutableType Instance for Reorganize Index Task

Reorganize Index Task defragments an index in a database table or view. An executable is a Reorganize Index Task executable if the **ExecutableType** attribute value is "Microsoft.SqlServer.Management.DatabaseMaintenance.DbMaintenanceDefragmentIndexTask, Microsoft.SqlServer.MaintenancePlanTasks, Version=10.0.0.0, Culture=neutral, PublicKeyToken=89845dcd8080cc91".

The Reorganize Index Task executable is formally defined to be of type [AnyNonPackageExecutableType](#). However, the following XSD fragment, which is expressed as an anonymous complex type declaration, places further restrictions on the type than the restrictions that are declared in the **AnyNonPackageExecutableType** type declaration. An [Executable](#) element with the **ExecutableType** attribute value equal to "Microsoft.SqlServer.Management.DatabaseMaintenance.DbMaintenanceDefragmentIndexTask, Microsoft.SqlServer.MaintenancePlanTasks, Version=10.0.0.0, Culture=neutral, PublicKeyToken=89845dcd8080cc91" MUST follow the anonymous type declaration that is contained in this section.

Note the following differences between this anonymous complex type declaration and the full definition of the complex type for the **AnyNonPackageExecutableType** type:

- This **Executable** element MUST NOT contain an **Executable** element.
- This **Executable** element MUST NOT contain a **ForEachEnumerator** element.
- This **Executable** element MUST NOT contain a **ForEachVariableMapping** element.
- In the **AnyNonPackageExecutableType** type, the type of the **ObjectData** element is given as [ExecutableObjectDataType](#). The **ExecutableObjectDataType** type definition contains an **xs:choice** XSD Schema element. However, not all of the choices that are allowed in the **xs:choice** XSD Schema element are available for the Reorganize Index Task executable. For this **Executable** element, the **ObjectData** element MUST contain the [SqlTaskData](#) element that is specified in the [SQLTask](#) namespace. The **SqlTaskData** element declaration in the **SQLTask** namespace MUST be replaced by the declaration and type that is specified in this section. This instance of the **SqlTaskData** element MUST NOT contain elements except for the **SelectedDatabases** element. This instance of the **SqlTaskData** element MUST NOT contain attributes other than those that are in the [SqlTaskBaseAttributeGroup](#) attribute group, the [MaintenanceTaskBaseAttributeGroup](#) attribute group, the **ReorganizeIndexTaskAttributeGroup** attribute group, and the **DatabaseSelectionType** attribute.
- The allowed values for the **Name** attribute of the **Property** element are a restricted subset of the values that are allowed on the type, as specified in the **AnyNonPackageExecutablePropertyNameEnum** type. Hence, the formal type declarations of the **Property** element and the **PropertyExpression** elements are replaced in this anonymous XSD fragment with a reference to the [TaskExePropertyNameEnum](#) simple type. The **Name** attribute of the **Property** element MUST be restricted to the values that are shown as valid in the XSD fragment that is contained in the **TaskExePropertyNameEnum** section.

For more information about the elements, attributes, and enumeration values in the following XSD fragment, see section 2.5.

```
<xs:complexType>
```



```

<xs:sequence>
  <xs:element name="ForEachEnumerator"
    type="DTS:ForEachEnumeratorType"
    minOccurs="0" maxOccurs="0"/>
  <xs:element name="Property"
    maxOccurs="unbounded">
    <xs:complexType>
      <xs:complexContent>
        <xs:extension base="DTS:PropertyElementBaseType">
          <xs:attribute name="Name"
            type="DTS:TaskExePropertyNameEnum"
            use="required"/>
        </xs:extension>
      </xs:complexContent>
    </xs:complexType>
  </xs:element>
  <xs:element name="Variable" type="DTS:VariableType"
    minOccurs="0" maxOccurs="unbounded"/>
  <xs:element name="LoggingOptions" type="DTS:LoggingOptionsType"/>
  <xs:element name="PropertyExpression"
    type="DTS:PropertyExpressionElementType"
    minOccurs="0" maxOccurs="unbounded"/>
  <xs:element name="PrecedenceConstraint"
    type="DTS:PrecedenceConstraintType"
    minOccurs="0" maxOccurs="unbounded"/>
  <xs:element name="ForEachVariableMapping"
    type="DTS:ForEachVariableMappingType"
    minOccurs="0" maxOccurs="0"/>
  <xs:element name="EventHandler" type="DTS:EventHandlerType"
    minOccurs="0" maxOccurs="unbounded"/>
  <xs:element name="ObjectData">
    <xs:complexType>
      <xs:choice>
        <xs:element ref="SQLTask:SqlTaskData"/>
      </xs:choice>
    </xs:complexType>
  </xs:element>
</xs:sequence>
<xs:attribute name="ExecutableType" use="required">
  <xs:simpleType>
    <xs:restriction base="xs:string">
      <xs:enumeration
value="Microsoft.SqlServer.Management.DatabaseMaintenance.DbMaintenanceDefragmentIndexTask,
Microsoft.SqlServer.MaintenancePlanTasks, Version=10.0.0.0, Culture=neutral,
PublicKeyToken=89845dcd8080cc91"/>
    </xs:restriction>
  </xs:simpleType>
</xs:attribute>
<xs:attribute name="ThreadHint" use="optional" type="xs:int"/>
</xs:complexType>

```

The preceding anonymous complex type definition requires that the declaration for the **SqlTaskData** element and its type, in the **SQLTask** namespace, be changed to the following.

```

<xs:element name="SqlTaskData"
  type="SQLTask:SqlTaskDataElementReorganizeIndexTaskType"/>
<xs:complexType
  name="SqlTaskDataElementReorganizeIndexTaskType">
  <xs:sequence>
    <xs:element name="SelectedDatabases"
      type="SQLTask:SelectedDatabasesType"
      minOccurs="0" maxOccurs="unbounded"/>
  </xs:sequence>
  <xs:attributeGroup
    ref="SQLTask:SqlTaskBaseAttributeGroup"/>
  <xs:attributeGroup
    ref="SQLTask:MaintenanceTaskBaseAttributeGroup"/>

```

```

<xs:attributeGroup
  ref="SQLTask:ReorganizeIndexTaskAttributeGroup"/>
<xs:attribute name="DatabaseSelectionType"
  type="SQLTask:SqlTaskDatabaseSelectionTypeEnum"/>
</xs:complexType>

```

2.6.4.9 ExecutableType Instance for Shrink Database Task

Shrink Database Task removes unused space from within database files. An executable is a Shrink Database Task executable if the **ExecutableType** attribute value is "Microsoft.SqlServer.Management.DatabaseMaintenance.DbMaintenanceShrinkTask, Microsoft.SqlServer.MaintenancePlanTasks, Version=10.0.0.0, Culture=neutral, PublicKeyToken=89845dcd8080cc91".

The Shrink Database Task executable is formally defined to be of type [AnyNonPackageExecutableType](#). However, the following XSD fragment, which is expressed as an anonymous complex type declaration, places further restrictions on the type than the restrictions that are declared in the **AnyNonPackageExecutableType** type declaration. An [Executable](#) element with the **ExecutableType** attribute value equal to "Microsoft.SqlServer.Management.DatabaseMaintenance.DbMaintenanceShrinkTask, Microsoft.SqlServer.MaintenancePlanTasks, Version=10.0.0.0, Culture=neutral, PublicKeyToken=89845dcd8080cc91" MUST follow the anonymous type declaration that is contained in this section.

Note the following differences between this anonymous complex type declaration and the full definition of the complex type for the **AnyNonPackageExecutableType** type:

- This **Executable** element MUST NOT contain an **Executable** element.
- This **Executable** element MUST NOT contain a **ForEachEnumerator** element.
- This **Executable** element MUST NOT contain a **ForEachVariableMapping** element.
- In the **AnyNonPackageExecutableType** type, the type of the **ObjectData** element is given as [ExecutableObjectDataType](#). The **ExecutableObjectDataType** type definition contains an **xs:choice** XSD Schema element. However, not all of the choices that are allowed in the **xs:choice** XSD Schema element are available for the Shrink Database Task executable. For this **Executable** element, the **ObjectData** element MUST contain the [SqlTaskData](#) element that is specified in the [SQLTask](#) namespace. The **SqlTaskData** element declaration in the **SQLTask** namespace MUST be replaced by the declaration and type that is specified in this section. This instance of the **SqlTaskData** element MUST NOT contain elements except for the **SelectedDatabases** element. This instance of the **SqlTaskData** element MUST NOT contain attributes other than those that are specified in the [SqlTaskBaseAttributeGroup](#) attribute group, the [MaintenanceTaskBaseAttributeGroup](#) attribute group, the [ShrinkDBTaskAttributeGroup](#) attribute group, and the **DatabaseSelectionType** attribute.
- The allowed values for the **Name** attribute of the **Property** element are a restricted subset of the values that are allowed on the type, as specified in the **AnyNonPackageExecutablePropertyNameEnum** type. Hence, the formal type declarations of the **Property** element and the **PropertyExpression** elements are replaced in this anonymous XSD fragment with a reference to the [TaskExePropertyNameEnum](#) simple type. The definition for the **TaskExePropertyNameEnum** type can be found in [Hyperlink: section TaskExePropertyNameEnum]. The **Name** attribute of the **Property** element MUST be restricted to the values that are shown as valid in the XSD fragment that is contained in the **TaskExePropertyNameEnum** section.

For more information about the elements, attributes, and enumeration values in the following XSD fragment, see section 2.5.

```

<xs:complexType>
  <xs:sequence>
    <xs:element name="ForEachEnumerator"
      type="DTS:ForEachEnumeratorType"
      minOccurs="0" maxOccurs="0"/>
    <xs:element name="Property"
      maxOccurs="unbounded">
      <xs:complexType>
        <xs:complexContent>
          <xs:extension base="DTS:PropertyElementBaseType">
            <xs:attribute name="Name"
              type="DTS:TaskExePropertyNameEnum"
              use="required"/>
          </xs:extension>
        </xs:complexContent>
      </xs:complexType>
    </xs:element>
    <xs:element name="Variable" type="DTS:VariableType"
      minOccurs="0" maxOccurs="unbounded"/>
    <xs:element name="LoggingOptions" type="DTS:LoggingOptionsType"/>
    <xs:element name="PropertyExpression"
      type="DTS:PropertyExpressionElementType"
      minOccurs="0" maxOccurs="unbounded"/>
    <xs:element name="PrecedenceConstraint"
      type="DTS:PrecedenceConstraintType"
      minOccurs="0" maxOccurs="unbounded"/>
    <xs:element name="ForEachVariableMapping"
      type="DTS:ForEachVariableMappingType"
      minOccurs="0" maxOccurs="0"/>
    <xs:element name="EventHandler" type="DTS:EventHandlerType"
      minOccurs="0" maxOccurs="unbounded"/>
    <xs:element name="ObjectData">
      <xs:complexType>
        <xs:choice>
          <xs:element ref="SQLTask:SqlTaskData"/>
        </xs:choice>
      </xs:complexType>
    </xs:element>
  </xs:sequence>
  <xs:attribute name="ExecutableType" use="required">
    <xs:simpleType>
      <xs:restriction base="xs:string">
        <xs:enumeration
          value="Microsoft.SqlServer.Management.DatabaseMaintenance.DbMaintenanceShrinkTask,
            Microsoft.SqlServer.MaintenancePlanTasks, Version=10.0.0.0, Culture=neutral,
            PublicKeyToken=89845dcd8080cc91"/>
      </xs:restriction>
    </xs:simpleType>
  </xs:attribute>
  <xs:attribute name="ThreadHint" use="optional" type="xs:int"/>
</xs:complexType>

```

The preceding anonymous complex type definition requires that the declaration for the **SqlTaskData** element and its type, in the **SQLTask** namespace, be changed to the following.

```

<xs:element name="SqlTaskData"
  type="SQLTask:SqlTaskDataElementShrinkDBTaskType"/>
<xs:complexType
  name="SqlTaskDataElementShrinkDBTaskType">
  <xs:sequence>
    <xs:element name="SelectedDatabases"
      type="SQLTask:SelectedDatabasesType"
      minOccurs="0" maxOccurs="unbounded"/>
  </xs:sequence>
  <xs:attributeGroup
    ref="SQLTask:SqlTaskBaseAttributeGroup"/>
</xs:complexType>

```

```

        ref="SQLTask:MaintenanceTaskBaseAttributeGroup"/>
<xs:attributeGroup
    ref="SQLTask:ShrinkDBTaskAttributeGroup"/>
<xs:attribute name="DatabaseSelectionType"
    type="SQLTask:SqlTaskDatabaseSelectionTypeEnum"/>
</xs:complexType>

```

2.6.4.10 ExecutableType Instance for Update Statistics Task

Update Statistics Task updates the statistics about key columns that are stored in a database. An executable is an Update Statistics Task executable if the **ExecutableType** attribute value is "Microsoft.SqlServer.Management.DatabaseMaintenance.DbMaintenanceUpdateStatisticsTask, Microsoft.SqlServer.MaintenancePlanTasks, Version=10.0.0.0, Culture=neutral, PublicKeyToken=89845dcd8080cc91".

The Update Statistics Task executable is formally defined to be of type [AnyNonPackageExecutableType](#). However, the following XSD fragment, which is expressed as an anonymous complex type declaration, places further restrictions on the type than the restrictions that are declared in the **AnyNonPackageExecutableType** type declaration. An [Executable](#) element with the **ExecutableType** attribute value equal to "Microsoft.SqlServer.Management.DatabaseMaintenance.DbMaintenanceUpdateStatisticsTask, Microsoft.SqlServer.MaintenancePlanTasks, Version=10.0.0.0, Culture=neutral, PublicKeyToken=89845dcd8080cc91" MUST follow the anonymous type declaration that is contained in this section.

Note the following differences between this anonymous complex type declaration and the full definition of the complex type for the **AnyNonPackageExecutableType** type:

- This **Executable** element MUST NOT contain an **Executable** element.
- This **Executable** element MUST NOT contain a **ForEachEnumerator** element.
- This **Executable** element MUST NOT contain a **ForEachVariableMapping** element.
- In the **AnyNonPackageExecutableType** type, the type of the **ObjectData** element is given as [ExecutableObjectDataType](#). The **ExecutableObjectDataType** type definition contains an **xs:choice** XSD Schema element. However, not all of the choices that are allowed in the **xs:choice** XSD Schema element are available for the Update Statistics Task executable. For this **Executable** element, the **ObjectData** element MUST contain the [SqlTaskData](#) element that is specified in the [SQLTask](#) namespace. The **SqlTaskData** element declaration in the **SQLTask** namespace MUST be replaced by the declaration and type that is specified in this section. This instance of the **SqlTaskData** element MUST NOT contain elements except for the **SelectedDatabases** element. This instance of the **SqlTaskData** element MUST NOT contain attributes other than those that are specified in the [SqlTaskBaseAttributeGroup](#) attribute group, the [MaintenanceTaskBaseAttributeGroup](#) attribute group, the [UpdateStatisticsTaskAttributeGroup](#) attribute group, and the **DatabaseSelectionType** attribute.
- The allowed values for the **Name** attribute of the **Property** element are a restricted subset of the values that are allowed on the type, as specified in the **AnyNonPackageExecutablePropertyNameEnum** type. Hence, the formal type declarations of the **Property** element and the **PropertyExpression** elements are replaced in this anonymous XSD fragment with a reference to the [TaskExePropertyNameEnum](#) simple type. The **Name** attribute of the **Property** element MUST be restricted to the values that are shown as valid in the XSD fragment that is contained in the **TaskExePropertyNameEnum** section.

For more information about the elements, attributes, and enumeration values in the following XSD fragment, see section 2.5.

```

<xs:complexType>
  <xs:sequence>
    <xs:element name="ForEachEnumerator"
      type="DTS:ForEachEnumeratorType"
      minOccurs="0" maxOccurs="0"/>
    <xs:element name="Property"
      maxOccurs="unbounded">
      <xs:complexType>
        <xs:complexContent>
          <xs:extension base="DTS:PropertyElementBaseType">
            <xs:attribute name="Name"
              type="DTS:TaskExePropertyNameEnum"
              use="required"/>
          </xs:extension>
        </xs:complexContent>
      </xs:complexType>
    </xs:element>
    <xs:element name="Variable" type="DTS:VariableType"
      minOccurs="0" maxOccurs="unbounded"/>
    <xs:element name="LoggingOptions" type="DTS:LoggingOptionsType"/>
    <xs:element name="PropertyExpression"
      type="DTS:PropertyExpressionElementType"
      minOccurs="0" maxOccurs="unbounded"/>
    <xs:element name="PrecedenceConstraint"
      type="DTS:PrecedenceConstraintType"
      minOccurs="0" maxOccurs="unbounded"/>
    <xs:element name="ForEachVariableMapping"
      type="DTS:ForEachVariableMappingType"
      minOccurs="0" maxOccurs="0"/>
    <xs:element name="EventHandler" type="DTS:EventHandlerType"
      minOccurs="0" maxOccurs="unbounded"/>
    <xs:element name="ObjectData">
      <xs:complexType>
        <xs:choice>
          <xs:element ref="SQLTask:SqlTaskData"/>
        </xs:choice>
      </xs:complexType>
    </xs:element>
  </xs:sequence>
  <xs:attribute name="ExecutableType" use="required">
    <xs:simpleType>
      <xs:restriction base="xs:string">
        <xs:enumeration
          value="Microsoft.SqlServer.Management.DatabaseMaintenance.DbMaintenanceUpdateStatisticsTask,
Microsoft.SqlServer.MaintenancePlanTasks, Version=10.0.0.0, Culture=neutral,
PublicKeyToken=89845dcd8080cc91"/>
      </xs:restriction>
    </xs:simpleType>
  </xs:attribute>
  <xs:attribute name="ThreadHint" use="optional" type="xs:int"/>
</xs:complexType>

```

The preceding anonymous complex type definition requires that the declaration for the **SqlTaskData** element and its type, in the **SQLTask** namespace, be changed to the following.

```

<xs:element name="SqlTaskData"
  type="SQLTask:SqlTaskDataElementUpdateStatisticsTaskType"/>
<xs:complexType
  name="SqlTaskDataElementUpdateStatisticsTaskType">
  <xs:sequence>
    <xs:element name="SelectedDatabases"
      type="SQLTask:SelectedDatabasesType"
      minOccurs="0" maxOccurs="unbounded"/>
  </xs:sequence>
  <xs:attributeGroup
    ref="SQLTask:SqlTaskBaseAttributeGroup"/>

```

```

<xs:attributeGroup
  ref="SQLTask:MaintenanceTaskBaseAttributeGroup"/>
<xs:attributeGroup
  ref="SQLTask:UpdateStatisticsTaskAttributeGroup"/>
<xs:attribute name="DatabaseSelectionType"
  type="SQLTask:SqlTaskDatabaseSelectionTypeEnum"/>
</xs:complexType>

```

2.6.4.11 ExecutableType Instance for Execute TSQL Task

Execute TSQL Task runs **Transact-SQL** (TSQL) language statements from a package. An executable is an Execute TSQL Task executable if the **ExecutableType** attribute value is "Microsoft.SqlServer.Management.DatabaseMaintenance.DbMaintenanceTSQLExecuteTask, Microsoft.SqlServer.MaintenancePlanTasks, Version=10.0.0.0, Culture=neutral, PublicKeyToken=89845dcd8080cc91".

The Execute TSQL Task executable is formally defined to be of type [AnyNonPackageExecutableType](#). However, the following XSD fragment, which is expressed as an anonymous complex type declaration, places further restrictions on the type than the restrictions that are declared in the **AnyNonPackageExecutableType** type declaration. An [Executable](#) element with the **ExecutableType** attribute value equal to "Microsoft.SqlServer.Management.DatabaseMaintenance.DbMaintenanceTSQLExecuteTask, Microsoft.SqlServer.MaintenancePlanTasks, Version=10.0.0.0, Culture=neutral, PublicKeyToken=89845dcd8080cc91" MUST follow the anonymous type declaration that is contained in this section.

Note the following differences between this anonymous complex type declaration and the full definition of the complex type for the **AnyNonPackageExecutableType** type:

- This **Executable** element MUST NOT contain an **Executable** element.
- This **Executable** element MUST NOT contain a **ForEachEnumerator** element.
- This **Executable** element MUST NOT contain a **ForEachVariableMapping** element.
- In the **AnyNonPackageExecutableType** type, the type of the **ObjectData** element is given as [ExecutableObjectDataType](#). The **ExecutableObjectDataType** type definition contains an **xs:choice** XSD Schema element. However, not all of the choices that are allowed in the **xs:choice** XSD Schema element are available for the Execute TSQL Task executable. For this **Executable** element, the **ObjectData** element MUST contain the [SqlTaskData](#) element that is specified in the [SQLTask](#) namespace. The **SqlTaskData** element declaration in the **SQLTask** namespace MUST be replaced by the declaration and type that is specified in this section. This instance of the **SqlTaskData** element MUST contain zero elements. This instance of the **SqlTaskData** element MUST NOT contain attributes other than those that are specified in the [SqlTaskBaseAttributeGroup](#) attribute group and the [MaintenanceTaskBaseAttributeGroup](#) attribute group.
- The allowed values for the **Name** attribute of the **Property** element are a restricted subset of the values that are allowed on the type, as specified in the **AnyNonPackageExecutablePropertyNameEnum** type. Hence, the formal type declarations of the **Property** element and the **PropertyExpression** elements are replaced in this anonymous XSD fragment with a reference to the [TaskExePropertyNameEnum](#) simple type. The **Name** attribute of the **Property** element MUST be restricted to the values that are shown as valid in the XSD fragment that is contained in the **TaskExePropertyNameEnum** section.

For more information about the elements, attributes, and enumeration values in the following XSD fragment, see section 2.5.

```

<xs:complexType>
  <xs:sequence>
    <xs:element name="ForEachEnumerator"
      type="DTS:ForEachEnumeratorType"
      minOccurs="0" maxOccurs="0"/>
    <xs:element name="Property"
      maxOccurs="unbounded">
      <xs:complexType>
        <xs:complexContent>
          <xs:extension base="DTS:PropertyElementBaseType">
            <xs:attribute name="Name"
              type="DTS:TaskExePropertyNameEnum"
              use="required"/>
          </xs:extension>
        </xs:complexContent>
      </xs:complexType>
    </xs:element>
    <xs:element name="Variable" type="DTS:VariableType"
      minOccurs="0" maxOccurs="unbounded"/>
    <xs:element name="LoggingOptions" type="DTS:LoggingOptionsType"/>
    <xs:element name="PropertyExpression"
      type="DTS:PropertyExpressionElementType"
      minOccurs="0" maxOccurs="unbounded"/>
    <xs:element name="PrecedenceConstraint"
      type="DTS:PrecedenceConstraintType"
      minOccurs="0" maxOccurs="unbounded"/>
    <xs:element name="ForEachVariableMapping"
      type="DTS:ForEachVariableMappingType"
      minOccurs="0" maxOccurs="0"/>
    <xs:element name="EventHandler" type="DTS:EventHandlerType"
      minOccurs="0" maxOccurs="unbounded"/>
    <xs:element name="ObjectData">
      <xs:complexType>
        <xs:choice>
          <xs:element ref="SQLTask:SqlTaskData"/>
        </xs:choice>
      </xs:complexType>
    </xs:element>
  </xs:sequence>
  <xs:attribute name="ExecutableType" use="required">
    <xs:simpleType>
      <xs:restriction base="xs:string">
        <xs:enumeration
          value="Microsoft.SqlServer.Management.DatabaseMaintenance.DbMaintenanceTSQLExecuteTask,
Microsoft.SqlServer.MaintenancePlanTasks, Version=10.0.0.0, Culture=neutral,
PublicKeyToken=89845dcd8080cc91"/>
      </xs:restriction>
    </xs:simpleType>
  </xs:attribute>
  <xs:attribute name="ThreadHint" use="optional" type="xs:int"/>
</xs:complexType>

```

The preceding anonymous complex type definition requires that the declaration for the **SqlTaskData** element and its type, in the **SQLTask** namespace, be changed to the following.

```

<xs:element name="SqlTaskData"
  type="SQLTask:SqlTaskDataElementTSQLExecuteTaskType"/>
<xs:complexType name="SqlTaskDataElementTSQLExecuteTaskType">
  <xs:sequence/>
  <xs:attributeGroup
    ref="SQLTask:SqlTaskBaseAttributeGroup"/>
  <xs:attributeGroup
    ref="SQLTask:MaintenanceTaskBaseAttributeGroup"/>
</xs:complexType>

```

2.7 Executable ObjectData Types

2.7.1 ExecutableObjectDataType

The **ExecutableObjectDataType** type is the type of the **ObjectData** element that occurs as a child element of many **Executable** elements. The choice made within the **xs:Choice** XSD element is constrained by the value of the **ExecutableType** attribute on the **Executable** element. These constraints MUST be adhered to. For more information about the constraint for each **ExecutableType** value, see [ExecutableType Attribute Values for Different Executable Types](#).

The following is the XSD of the **ExecutableObjectDataType** type.

```
<xs:complexType name="ExecutableObjectDataType">
  <xs:choice minOccurs="0">
    <xs:element name="pipeline" type="DTS:pipelineObjectDataType"
      form="unqualified"/>
    <xs:element ref="ActiveXScriptTask:ActiveXScriptTaskData" />
    <xs:element name="ASDdlData" type="DTS:ASDdlDataObjectDataType"
      form="unqualified"/>
    <xs:element name="ASProcessingData" form="unqualified"
      type="DTS:ASProcessingDataObjectDataType"/>
    <xs:element ref="BulkInsertTask:BulkInsertTaskData"/>
    <xs:element name="DMQueryTaskData" form="unqualified"
      type="DTS:DMQueryTaskDataObjectDataType"/>
    <xs:element name="DataProfilingTaskData" form="unqualified"
      type="DTS:DataProfilingTaskDataObjectDataType"/>
    <xs:element ref="Exec80PackageTask:Exec80PackageTaskData"/>
    <xs:element name="ExecutePackageTask" form="unqualified"
      type="DTS:ExecutePackageTaskObjectDataType"/>
    <xs:element name="ExecuteProcessData" form="unqualified"
      type="DTS:ExecuteProcessDataObjectDataType"/>
    <xs:element ref="SQLTask:SqlTaskData"/>
    <xs:element name="FileSystemData" form="unqualified"
      type="DTS:FileSystemDataObjectDataType"/>
    <xs:element name="FtpData" type="DTS:FtpDataObjectDataType"
      form="unqualified"/>
    <xs:element ref="MessageQueueTask:MessageQueueTaskData"/>
    <xs:element name="ScriptProject" type="DTS:ScriptProjectObjectDataType"
      form="unqualified"/>
    <xs:element ref="SendMailTask:SendMailTaskData"/>
    <xs:element name="TransferDatabasesTaskData" form="unqualified"
      type="DTS:TransferDatabasesTaskDataObjectDataType"/>
    <xs:element name="TransferErrorMessagesTaskData" form="unqualified"
      type="DTS:TransferErrorMessagesTaskDataObjectDataType"/>
    <xs:element name="TransferJobsTaskData" form="unqualified"
      type="DTS:TransferJobsTaskDataObjectDataType"/>
    <xs:element name="TransferLoginsTaskData" form="unqualified"
      type="DTS:TransferLoginsTaskDataObjectDataType"/>
    <xs:element name="TransferStoredProceduresTaskData" form="unqualified"
      type="DTS:TransferStoredProceduresTaskDataObjectDataType"/>
    <xs:element name="TransferSqlServerObjectsTaskData" form="unqualified"
      type="DTS:TransferSqlServerObjectsTaskDataObjectDataType"/>
    <xs:element ref="WSTask:WebServiceTaskData"/>
    <xs:element name="WMIDRTaskData" type="DTS:WMIDRTaskDataObjectDataType"
      form="unqualified"/>
    <xs:element name="WMIEWTaskData" type="DTS:WMIEWTaskDataObjectDataType"
      form="unqualified"/>
    <xs:element name="XMLTaskData" type="DTS:XMLTaskDataObjectDataType"
      form="unqualified"/>
    <xs:element name="InnerObject" type="DTS:InnerObjectObjectDataType"
      form="unqualified"/>
  </xs:choice>
</xs:complexType>
```

2.7.1.1 pipelineObjectType

The **pipelineObjectType** type is used to specify the parameters, properties, and settings that are specific to a Pipeline Task executable.

The following is the XSD for the **pipelineObjectType** type.

```
<xs:complexType name="pipelineObjectType">
  <xs:sequence>
    <xs:sequence>
      <xs:element name="components" type="DTS:PipelineComponentsType"
        form="unqualified"/>
      <xs:element name="paths" type="DTS:PipelinePathsType"
        minOccurs="0" form="unqualified"/>
    </xs:sequence>
  </xs:sequence>
  <xs:attribute name="id" type="xs:int" form="unqualified"/>
  <xs:attribute name="name" type="xs:string" form="unqualified"/>
  <xs:attribute name="description" type="xs:string"
    form="unqualified"/>
  <xs:attribute name="defaultBufferMaxRows" type="xs:int"
    form="unqualified"/>
  <xs:attribute name="engineThreads" type="xs:int"
    form="unqualified"/>
  <xs:attribute name="defaultBufferSize" type="xs:int"
    form="unqualified"/>
  <xs:attribute name="BLOBTempStoragePath" type="xs:string"
    form="unqualified"/>
  <xs:attribute name="bufferTempStoragePath" type="xs:string"
    form="unqualified"/>
  <xs:attribute name="runInOptimizedMode" type="xs:boolean"
    form="unqualified"/>
</xs:complexType>
```

The following table specifies the elements of the **pipelineObjectType** type.

| Element | Type definition | Description |
|-------------------|--|--|
| components | PipelineComponentsType | A complex type that specifies a collection of component elements. Each component element represents one node of the pipeline process. |
| paths | PipelinePathsType | A complex type that specifies a collection of path elements. Each path element represents one path of data flow within the pipeline process. |

The following table specifies the attributes of the **pipelineObjectType** type.

| Attribute | Description |
|-----------------------------|---|
| id | An integer value that specifies the identifier for this pipeline element. Other elements can refer to this pipeline element by using this id value. |
| name | A string value that specifies the name for this pipeline element. |
| description | A string value that specifies the description for this pipeline element. |
| defaultBufferMaxRows | An integer value that specifies the maximum number of rows for the default buffer. <19> |
| engineThreads | An integer value that specifies a suggestion to the data flow engine about the number of threads to use. <20> |

| Attribute | Description |
|------------------------------|---|
| defaultBufferSize | An integer value that specifies the number of bytes to allocate by default for temporary buffer storage. <21> |
| BLOBTempStoragePath | A string value that specifies a folder that is used for temporary storage of BLOB columns during the execution of the task. <22> |
| bufferTempStoragePath | A string value that specifies a folder that is used for temporary buffer storage during the execution of the task. <23> |
| runInOptimizedMode | A Boolean value that specifies whether to run the task in optimized mode. Optimized mode removes unused columns, outputs, and components from the data flow. TRUE specifies that the task is run in optimized mode. FALSE specifies that the task is not run in optimized mode. |

2.7.1.1.1 PipelineComponentsType

The **PipelineComponentsType** type specifies a collection of component objects for a Pipeline Task executable.

The following is the XSD for the **PipelineComponentsType** type.

```
<xs:complexType name="PipelineComponentsType">
  <xs:sequence>
    <xs:element name="component" type="DTS:PipelineComponentType"
      form="unqualified" maxOccurs="unbounded"/>
  </xs:sequence>
</xs:complexType>
```

The following table specifies the elements of the **PipelineComponentsType** type.

| Element | Type definition | Description |
|------------------|---------------------------------------|---|
| component | PipelineComponentType | A complex type that specifies a single component within a pipeline. |

2.7.1.1.1.1 PipelineComponentType

The **PipelineComponentType** type specifies a single component within a Pipeline Task executable. Each component represents a single operation within a Pipeline Task.

The following is the XSD for the **PipelineComponentType** type.

```
<xs:complexType name="PipelineComponentType">
  <xs:sequence>
    <xs:element name="properties" form="unqualified"
      type="DTS:PipelineComponentPropertiesType"
      minOccurs="0"/>
    <xs:element name="connections" form="unqualified"
      type="DTS:PipelineComponentConnectionsType"
      minOccurs="0"/>
    <xs:element name="inputs" form="unqualified"
      type="DTS:PipelineComponentInputsType"
      minOccurs="0"/>
    <xs:element name="outputs" form="unqualified"
      type="DTS:PipelineComponentOutputsType"
```

```

        minOccurs="0"/>
</xs:sequence>
<xs:attribute name="id" type="xs:int" form="unqualified"/>
<xs:attribute name="name" type="xs:string" form="unqualified"/>
<xs:attribute name="componentClassID"
    type="DTS:PipelineComponentComponentClassIDEnum"
    form="unqualified"/>
<xs:attribute name="description" type="xs:string"
    form="unqualified"/>
<xs:attribute name="localeId" type="xs:int" form="unqualified"/>
<xs:attribute name="usesDispositions" type="xs:boolean"
    form="unqualified"/>
<xs:attribute name="validateExternalMetadata" form="unqualified">
    <xs:simpleType>
        <xs:restriction base="xs:string">
            <xs:enumeration value="True"/>
            <xs:enumeration value="False"/>
        </xs:restriction>
    </xs:simpleType>
</xs:attribute>
<xs:attribute name="version" type="xs:int" form="unqualified"/>
<xs:attribute name="pipelineVersion" type="xs:int"
    form="unqualified"/>
<xs:attribute name="contactInfo" type="xs:string"
    form="unqualified"/>
</xs:complexType>

```

The following table specifies the elements of the **PipelineComponentType** type.

| Element | Type definition | Description |
|--------------------|--|---|
| properties | PipelineComponentPropertiesType | A complex type that specifies a collection of property elements for the component. |
| connections | PipelineComponentConnectionsType | A complex type that specifies a collection of connection elements for the component. |
| inputs | PipelineComponentInputsType | A complex type that specifies a collection of input elements that represent inputs arriving at this component. |
| outputs | PipelineComponentOutputsType | A complex type that specifies a collection of output elements that represent outputs coming from this component. |

The following table specifies the attributes of the **PipelineComponentType** type.

| Attribute | Description |
|-------------------------|--|
| id | An integer value that specifies an identifier for this component element. Other elements can refer to this component instance by using this id value. |
| name | A string value that specifies the name for this component element. |
| componentClassID | An enumeration value that specifies the Class ID for this component. |
| description | A string value that specifies the description for this component element. |
| localeId | An integer value that specifies the language code identifier (LCID) for this component element. |
| usesDispositions | A Boolean value that specifies whether the component has an output path for errors. TRUE specifies that the component has an output path for errors. |

| Attribute | Description |
|---------------------------------|--|
| | FALSE specifies that the component does not have an output path for errors. |
| validateExternalMetadata | The validateExternalMetadata attribute value is not used by the data transformation processing engine. <24> |
| version | An integer value that specifies the version of the component. |
| pipelineVersion | An integer value that specifies the version of the task within which a component is designed to execute. |
| contactInfo | A string value that specifies contact information for the developer of a component. <25> |

2.7.1.1.1.1.1 PipelineComponentPropertiesType

The **PipelineComponentPropertiesType** type specifies a collection of properties of a component.

The following is the XSD for the **PipelineComponentPropertiesType** type.

```
<xs:complexType name="PipelineComponentPropertiesType">
  <xs:sequence>
    <xs:element name="property" form="unqualified"
      type="DTS:PipelineComponentPropertyType"
      minOccurs="0" maxOccurs="unbounded"/>
  </xs:sequence>
</xs:complexType>
```

The following table specifies the elements of the **PipelineComponentPropertiesType** type.

| Element | Type definition | Description |
|-----------------|---|--|
| property | PipelineComponentPropertyType | A complex type that specifies a property of a component or of a component input, output, or metadata column. |

2.7.1.1.1.1.1.1 PipelineComponentPropertyType

The **PipelineComponentPropertyType** type specifies the structure in which the value for a single property of a component is held. All components do not use the same set of properties, so this general structure is designed to hold the variety of properties that a component can have.

The following is the XSD for the **PipelineComponentPropertyType** type.

```
<xs:complexType name="PipelineComponentPropertyType" mixed="true">
  <xs:sequence>
    <xs:element name="arrayElements"
      type="DTS:PipelineComponentArrayElementsType"
      form="unqualified" minOccurs="0"/>
  </xs:sequence>
  <xs:attribute name="name"
    type="DTS:PipelineComponentPropertyNameEnum"
    form="unqualified"/>
  <xs:attributeGroup
    ref="DTS:PipelineComponentPropertyAttributeGroup"/>
</xs:complexType>
```

The following table specifies the elements of the **PipelineComponentPropertyType** type.

| Element | Type definition | Description |
|----------------------|--|---|
| arrayElements | PipelineComponentArrayElementsType | A complex type that contains a collection of elements that form an array. The collection constitutes the value for the property. This type is used only if the value of the isArray attribute is TRUE. |

The following table specifies the attributes of the **PipelineComponentPropertyType** type.

| Attribute | Description |
|--|---|
| PipelineComponentPropertyAttributeGroup | An attribute group that contains attributes that are common to all property elements for input elements, output elements, inputColumn elements, and outputColumn elements. |
| name | A string value that specifies the name of the property. |

2.7.1.1.1.1.1.1.1 PipelineComponentArrayElementsType

The **PipelineComponentArrayElementsType** type specifies a collection of component objects for a Pipeline Task executable.

The following is the XSD for the **PipelineComponentArrayElementsType** type.

```
<xs:complexType name="PipelineComponentArrayElementsType">
  <xs:sequence>
    <xs:element name="arrayElement"
      type="DTS:PipelineComponentArrayType"
      form="unqualified" minOccurs="0" maxOccurs="unbounded"/>
  </xs:sequence>
  <xs:attribute name="arrayElementCount" type="xs:int"
    form="unqualified"/>
</xs:complexType>
```

The following table specifies the elements of the **PipelineComponentArrayElementsType** type.

| Element | Type definition | Description |
|---------------------|----------------------------|--|
| arrayElement | PipelineComponentArrayType | A complex type that specifies a single array element that is a member of the array of elements that is the value of a pipeline property. |

2.7.1.1.1.1.1.1.1.1 PipelineComponentArrayType

The **PipelineComponentArrayType** type specifies a collection of component objects for a Pipeline Task executable.

The following is the XSD for the **PipelineComponentArrayType** type.

```
<xs:complexType name="PipelineComponentArrayType">
  <xs:simpleContent>
    <xs:extension base="xs:anySimpleType">
      <xs:attribute name="dataType"
        type="DTS:PipelineComponentDataTypeEnum"
        form="unqualified"/>
    </xs:extension>
  </xs:simpleContent>
</xs:complexType>
```

```

    </xs:simpleContent>
  </xs:complexType>

```

The following table specifies the attributes of the **PipelineComponentArrayType** type.

| Attribute | Description |
|-----------------|---|
| dataType | An enumeration value that specifies the type of the data that is contained in the value for the array element. |

2.7.1.1.1.1.1.2 PipelineComponentPropertyNameEnum

The **PipelineComponentPropertyNameEnum** type contains the allowed values for the **name** attribute on the **component** element of a Pipeline Task executable. The allowed values for the **property** element for each task are more restricted than the values that are specified formally by the XSD.

Each **name** attribute value MUST NOT be used for any component except for the components that are specified in the subsections of this section. Some components allow no properties.

The additional restrictions specified in the subsections of this section MUST be followed for the **name** attribute on the **property** element children of the **component** element.

The following is the XSD for the **PipelineComponentPropertyNameEnum** type.

```

<xs:simpleType name="PipelineComponentPropertyNameEnum">
  <xs:restriction base="xs:string">
    <!--Transforms-->
    <!--Aggregate Task-->
    <xs:enumeration value="KeyScale"/>
    <xs:enumeration value="Keys"/>
    <xs:enumeration value="CountDistinctScale"/>
    <xs:enumeration value="CountDistinctKeys"/>
    <xs:enumeration value="AutoExtendFactor"/>
    <!--Audit (none)-->
    <!--Cache Transform (none)-->
    <!--Character Map (none)-->
    <!--Conditional Split (none)-->
    <!--Copy Column (none)-->
    <!--Data Conversion (none)-->
    <!--Data Mining Query-->
    <xs:enumeration value="ObjectRef"/>
    <xs:enumeration value="QueryText"/>
    <xs:enumeration value="CatalogName"/>
    <!--Derived Column Query (none)-->
    <!--Export Column Query (none)-->
    <!--Fuzzy Grouping-->
    <xs:enumeration value="MinSimilarity"/>
    <xs:enumeration value="Delimiters"/>
    <xs:enumeration value="MaxMemoryUsage"/>
    <xs:enumeration value="Exhaustive"/>
    <!--Fuzzy Lookup-->
    <xs:enumeration value="MatchIndexOptions"/>
    <xs:enumeration value="MaxMemoryUsage"/>
    <xs:enumeration value="MatchIndexName"/>
    <xs:enumeration value="ReferenceTableName"/>
    <xs:enumeration value="DropExistingMatchIndex"/>
    <xs:enumeration value="CopyReferenceTable"/>
    <xs:enumeration value="MaxOutputMatchesPerInput"/>
    <xs:enumeration value="MinSimilarity"/>
    <xs:enumeration value="Delimiters"/>
  </xs:restriction>
</xs:simpleType>

```

```

<xs:enumeration value="ReferenceMetadataXml"/>
<xs:enumeration value="Exhaustive"/>
<xs:enumeration value="WarmCaches"/>
<!--Import Column (none)-->
<!--Lookup-->
<xs:enumeration value="SqlCommand"/>
<xs:enumeration value="SqlCommandParam"/>
<xs:enumeration value="ConnectionType"/>
<xs:enumeration value="CacheType"/>
<xs:enumeration value="NoMatchBehavior"/>
<xs:enumeration value="NoMatchCachePercentage"/>
<xs:enumeration value="MaxMemoryUsage"/>
<xs:enumeration value="MaxMemoryUsage64"/>
<xs:enumeration value="ReferenceMetadataXml"/>
<xs:enumeration value="ParameterMap"/>
<xs:enumeration value="DefaultCodePage"/>
<!--Merge (none)-->
<!--MergeJoin (none)-->
<xs:enumeration value="JoinType"/>
<xs:enumeration value="NumKeyColumns"/>
<xs:enumeration value="TreatNullsAsEqual"/>
<xs:enumeration value="MaxBuffersPerInput"/>
<!--Multicast (none)-->
<!--OLE DB Command-->
<xs:enumeration value="CommandTimeout"/>
<xs:enumeration value="SqlCommand"/>
<xs:enumeration value="DefaultCodePage"/>
<!--Percentage Sampling-->
<xs:enumeration value="SamplingValue"/>
<xs:enumeration value="SamplingSeed"/>
<!--Pivot (none)-->
<!--RowCount-->
<xs:enumeration value="VariableName"/>
<!--Row Sampling-->
<xs:enumeration value="SamplingValue"/>
<xs:enumeration value="SamplingSeed"/>
<!--Script Component-->
<xs:enumeration value="SourceCode"/>
<xs:enumeration value="BinaryCode"/>
<xs:enumeration value="VSTAProjectName"/>
<xs:enumeration value="ScriptLanguage"/>
<xs:enumeration value="ReadOnlyVariables"/>
<xs:enumeration value="ReadWriteVariables"/>
<xs:enumeration value="BreakpointCollection"/>
<xs:enumeration value="UserComponentTypeName"/>
<!--Slowly Changing Dimension-->
<xs:enumeration value="SqlCommand"/>
<xs:enumeration value="CurrentRowWhere"/>
<xs:enumeration value="UpdateChangingAttributeHistory"/>
<xs:enumeration value="FailOnFixedAttributeChange"/>
<xs:enumeration value="InferredMemberIndicator"/>
<xs:enumeration value="EnableInferredMember"/>
<xs:enumeration value="FailOnLookupFailure"/>
<xs:enumeration value="IncomingRowChangeType"/>
<xs:enumeration value="DefaultCodePage"/>
<!--Sort-->
<xs:enumeration value="EliminateDuplicates"/>
<xs:enumeration value="MaximumThreads"/>
<!--Term Extraction-->
<xs:enumeration value="NeedReferenceData"/>
<xs:enumeration value="OutTermTable"/>
<xs:enumeration value="OutTermColumn"/>
<xs:enumeration value="WordOrPhrase"/>
<xs:enumeration value="ScoreType"/>
<xs:enumeration value="FrequencyThreshold"/>
<xs:enumeration value="MaxLengthOfTerm"/>
<xs:enumeration value="IsCaseSensitive"/>
<!--Term Lookup-->
<xs:enumeration value="RefTermTable"/>

```

```

<xs:enumeration value="RefTermColumn"/>
<xs:enumeration value="IsCaseSensitive"/>
<!--UnionAll (none)-->
<!--Unpivot (none)-->
<!--Data Destinations-->
<!--ADO.Net Destination-->
<xs:enumeration value="TableOrViewName"/>
<xs:enumeration value="BatchSize"/>
<xs:enumeration value="CommandTimeout"/>
<xs:enumeration value="UserComponentTypeName"/>
<!--Excel Destination-->
<xs:enumeration value="CommandTimeout"/>
<xs:enumeration value="OpenRowset"/>
<xs:enumeration value="OpenRowsetVariable"/>
<xs:enumeration value="SqlCommand"/>
<xs:enumeration value="AccessMode"/>
<xs:enumeration value="FastLoadKeepIdentity"/>
<xs:enumeration value="FastLoadKeepNulls"/>
<xs:enumeration value="FastLoadOptions"/>
<xs:enumeration value="FastLoadMaxInsertCommitSize"/>
<!--Flat File Destination-->
<xs:enumeration value="Overwrite"/>
<xs:enumeration value="Header"/>
<!--OLE DB Destination-->
<xs:enumeration value="CommandTimeout"/>
<xs:enumeration value="OpenRowset"/>
<xs:enumeration value="OpenRowsetVariable"/>
<xs:enumeration value="SqlCommand"/>
<xs:enumeration value="DefaultCodePage"/>
<xs:enumeration value="AlwaysUseDefaultCodePage"/>
<xs:enumeration value="AccessMode"/>
<xs:enumeration value="FastLoadKeepIdentity"/>
<xs:enumeration value="FastLoadKeepNulls"/>
<xs:enumeration value="FastLoadOptions"/>
<xs:enumeration value="FastLoadMaxInsertCommitSize"/>
<!--Raw File Destination-->
<xs:enumeration value="AccessMode"/>
<xs:enumeration value="FileName"/>
<xs:enumeration value="FileNameVariable"/>
<xs:enumeration value="WriteOption"/>
<!--DataReader Destination-->
<xs:enumeration value="ReadTimeout"/>
<xs:enumeration value="DataReader"/>
<xs:enumeration value="FailOnTimeout"/>
<xs:enumeration value="UserComponentTypeName"/>
<!--Data Mining Model Training-->
<xs:enumeration value="ObjectRef"/>
<!--Dimension Processing-->
<xs:enumeration value="ObjectRef"/>
<xs:enumeration value="UseDefaultConfiguration"/>
<xs:enumeration value="KeyErrorLimit"/>
<xs:enumeration value="KeyErrorLogFile"/>
<xs:enumeration value="KeyErrorAction"/>
<xs:enumeration value="KeyErrorLimitAction"/>
<xs:enumeration value="KeyNotFound"/>
<xs:enumeration value="KeyDuplicate"/>
<xs:enumeration value="NullKeyConvertedToUnknown"/>
<xs:enumeration value="NullKeyNotAllowed"/>
<xs:enumeration value="ProcessType"/>
<!--Partition Processing-->
<xs:enumeration value="ObjectRef"/>
<xs:enumeration value="UseDefaultConfiguration"/>
<xs:enumeration value="KeyErrorLimit"/>
<xs:enumeration value="KeyErrorLogFile"/>
<xs:enumeration value="KeyErrorAction"/>
<xs:enumeration value="KeyErrorLimitAction"/>
<xs:enumeration value="KeyNotFound"/>
<xs:enumeration value="KeyDuplicate"/>
<xs:enumeration value="NullKeyConvertedToUnknown"/>

```



```

<xs:enumeration value="NullKeyNotAllowed"/>
<xs:enumeration value="ProcessType"/>
<!--RecordSet Destination-->
<xs:enumeration value="VariableName"/>
<!--SQL Server Compact Destination-->
<xs:enumeration value="Table Name"/>
<xs:enumeration value="UserComponentTypeName"/>
<!--SQL Server Destination-->
<xs:enumeration value="DefaultCodePage"/>
<xs:enumeration value="AlwaysUseDefaultCodePage"/>
<xs:enumeration value="BulkInsertTableName"/>
<xs:enumeration value="BulkInsertCheckConstraints"/>
<xs:enumeration value="BulkInsertFirstRow"/>
<xs:enumeration value="BulkInsertFireTriggers"/>
<xs:enumeration value="BulkInsertKeepIdentity"/>
<xs:enumeration value="BulkInsertKeepNulls"/>
<xs:enumeration value="BulkInsertLastRow"/>
<xs:enumeration value="BulkInsertMaxErrors"/>
<xs:enumeration value="BulkInsertOrder"/>
<xs:enumeration value="BulkInsertTablock"/>
<xs:enumeration value="Timeout"/>
<xs:enumeration value="MaxInsertCommitSize"/>
<!--Data Sources-->
<!--ADO.Net Source-->
<xs:enumeration value="SqlCommand"/>
<xs:enumeration value="CommandTimeout"/>
<xs:enumeration value="AllowImplicitStringConversion"/>
<xs:enumeration value="TableOrViewName"/>
<xs:enumeration value="AccessMode"/>
<xs:enumeration value="UserComponentTypeName"/>
<!--Excel Source-->
<xs:enumeration value="CommandTimeout"/>
<xs:enumeration value="OpenRowset"/>
<xs:enumeration value="OpenRowsetVariable"/>
<xs:enumeration value="SqlCommand"/>
<xs:enumeration value="SqlCommandVariable"/>
<xs:enumeration value="AccessMode"/>
<xs:enumeration value="ParameterMapping"/>
<!--Flat File Source-->
<xs:enumeration value="RetainNulls"/>
<xs:enumeration value="FileNameColumnName"/>
<!--OLEDB Source Task-->
<xs:enumeration value="CommandTimeout"/>
<xs:enumeration value="OpenRowset"/>
<xs:enumeration value="OpenRowsetVariable"/>
<xs:enumeration value="SqlCommand"/>
<xs:enumeration value="SqlCommandVariable"/>
<xs:enumeration value="DefaultCodePage"/>
<xs:enumeration value="AlwaysUseDefaultCodePage"/>
<xs:enumeration value="AccessMode"/>
<xs:enumeration value="ParameterMapping"/>
<!--Raw File Source-->
<xs:enumeration value="AccessMode"/>
<xs:enumeration value="FileName"/>
<xs:enumeration value="FileNameVariable"/>
<!--XML Source-->
<xs:enumeration value="UserComponentTypeName"/>
<xs:enumeration value="XMLData"/>
<xs:enumeration value="XMLDataVariable"/>
<xs:enumeration value="AccessMode"/>
<xs:enumeration value="XMLSchemaDefinition"/>
<xs:enumeration value="UseInlineSchema"/>
</xs:restriction>
</xs:simpleType>

```

This section presents no tabular explanation of the properties that are specified in the preceding XSD. Tabular explanations are, however, presented in the following subsections when values are allowed.

2.7.1.1.1.1.1.2.1 Aggregate Component

Aggregate Component aggregates values by using functions such as sum and average. Aggregate Component MUST NOT use any **Name** attribute value on a **property** element except for those that are listed in the table in this section.

The following table specifies the **Name** attribute values that are allowed for the Aggregate Component, in addition to any restrictions on the element value. These restrictions MUST be followed.

| Name attribute value | Description |
|-----------------------------|--|
| KeyScale | An integer value that specifies the approximate number of groups that is expected by the operation. This value is used to optimize computation. The possible enumeration values are interpreted as follows: 0 – The key scale is not used. 1 – Aggregation writes approximately 500,000 keys. 2 – Aggregation writes approximately 25,000,000 keys. 3 – Aggregation writes more than 25,000,000 keys. |
| Keys | An integer value that specifies the number of groups that is expected by the operation. This value is used to optimize computation. If this value is specified, it overrides the value that is specified for the KeyScale attribute. |
| CountDistinctScale | An integer value that specifies the approximate number of groups that is expected by a distinct count operation. This value is used to optimize computation. The enumeration values are interpreted as follows: 0 – The key scale is not used. 1 – Aggregation writes approximately 500,000 keys. 2 – Aggregation writes approximately 25,000,000 keys. 3 – Aggregation writes more than 25,000,000 keys. |
| CountDistinctKeys | An integer value that specifies the number of groups that is expected by a distinct count operation. This value is used to optimize computation. If this value is specified, it overrides the value that is specified for the CountDistinctKeys attribute. |
| AutoExtendFactor | An integer value that specifies the percentage amount by which memory is extended during the aggregate operation. |

2.7.1.1.1.1.1.2.2 Audit Component

Audit Component allows information about the run-time environment of the package to be inserted into the data flow. Audit Component MUST NOT have any properties.

2.7.1.1.1.1.1.2.3 Cache Transform Component

Cache Transform Component copies its inputs to a cache for fast processing. Cache Transform Component MUST NOT have any properties.

2.7.1.1.1.1.1.2.4 Character Map Component

Character Map Component processes character strings by applying string functions to the strings, such as converting case and byte order. Character Map Component MUST NOT have any properties.

2.7.1.1.1.1.1.2.5 Conditional Split Component

Conditional Split Component splits its input into several outputs, based on conditional logic to determine which output to use for each input row. Conditional Split Component MUST NOT have any properties.

2.7.1.1.1.1.1.2.6 Copy Column Component

Copy Column Component produces a copy of a column on its output. Copy Column Component MUST NOT have any properties.

2.7.1.1.1.1.1.2.7 Data Conversion Component

Data Conversion Component converts the data type of a column to a different data type. Data Conversion Component MUST NOT have any properties.

2.7.1.1.1.1.1.2.8 Data Mining Query Component

Data Mining Query Component runs data mining prediction queries. Data Mining Query Component MUST NOT use any **Name** attribute value on a **property** element except for those that are listed in the table in this section.

The following table specifies the **Name** attribute values that are allowed for the Data Mining Query Component, in addition to any restrictions on the element value. These restrictions MUST be followed.

| Name attribute value | Description |
|-----------------------------|---|
| ObjectRef | A string value that specifies an XML tag that identifies the mining structure that the task uses. |
| QueryText | A string value that specifies a Data Mining Query Language (DMX) query string. For more information about the DMX language, see [MSDN-DMXR] . |
| CatalogName | A string value that specifies the catalog name in the host database for the data mining model. |

2.7.1.1.1.1.1.2.9 Derived Column Component

Derived Column Component produces new columns by computing them from an expression. Derived Column Component MUST NOT have any properties.

2.7.1.1.1.1.1.2.10 Export Column Component

Export Column Component takes data from the data flow and inserts it into files. Export Column Component MUST NOT have any properties.

2.7.1.1.1.1.1.2.11 Fuzzy Grouping Component

Fuzzy Grouping Component identifies rows of data that are similar enough to be grouped, if the grouping criteria is considered to be fuzzy and not exact. Fuzzy Grouping Component MUST NOT use any **Name** attribute value on a **property** element except for those that are listed in the table in this section.

The following table specifies the **Name** attribute values that are allowed for the Fuzzy Grouping Component, in addition to any restrictions on the element value. All stated restrictions MUST be followed.

| Name attribute value | Description |
|-----------------------------|--|
| MinSimilarity | A single-precision number value between 0 and 1, inclusive, that specifies the similarity threshold that the task uses to identify duplicates. |

| Name attribute value | Description |
|-----------------------|--|
| Delimiters | A string value that specifies the tokens that the task uses as delimiters. |
| MaxMemoryUsage | An integer value that specifies the maximum memory usage for the task in bytes.<26> |
| Exhaustive | A Boolean value that specifies whether each input record is compared to every other input record. TRUE specifies that each input record is compared to every other input record. FALSE specifies that each input record is not compared to every other input record. |

2.7.1.1.1.1.1.2.12 **Fuzzy Lookup Component**

Fuzzy Lookup Component looks up values in a table and matches them based on similarity and, therefore, does not require an exact match. The match is considered to have been made based on fuzzy criteria. Fuzzy Lookup Component **MUST NOT** use any **Name** attribute value on a **property** element except for those that are listed in the table in this section.

The following table specifies the **Name** attribute values that are allowed for Fuzzy Lookup Component, in addition to any restrictions on the element value. All stated restrictions **MUST** be followed.

| Name attribute value | Description |
|---------------------------------|--|
| MatchIndexOptions | An integer value that specifies how the match index is managed. The possible values have the following meanings: 0 – Reuse existing index. 1 – Generate a new index. 2 – Generate and persist a new index. 3 – Generate and maintain a new index. |
| MaxMemoryUsage | An integer value that specifies the maximum size for the cache table in bytes.<27> |
| MatchIndexName | A string value that specifies the name of the match index. The match index is the table in which the transformation creates and saves the index that it uses. |
| ReferenceTableName | A string value that specifies the name of the lookup table.<28> |
| DropExistingMatchIndex | A Boolean value that specifies whether the match index that is specified in the MatchIndexName attribute is deleted when the MatchIndexOptions attribute is not set to the value "ReuseExistingIndex". |
| CopyReferenceTable | A Boolean value that specifies whether a copy of the reference table is made for index construction and for subsequent lookups. TRUE specifies that a copy of the reference table is made. FALSE specifies that a copy of the reference table is not made. |
| MaxOutputMatchesPerInput | An integer value that specifies the maximum number of matches that can be returned for each input row. |
| MinSimilarity | A single-precision number between 0 and 1, inclusive, that specifies the similarity threshold that the task uses to identify duplicates. |
| Delimiters | A string value that specifies the tokens that the task uses as delimiters. |
| ReferenceMetadataXml | A string value.<29> |
| Exhaustive | A Boolean value that specifies whether each input record is compared to every other input record. |

| Name attribute value | Description |
|----------------------|---|
| | TRUE specifies that each input record is compared to every other input record. FALSE specifies that each input record is not compared to every other input record. |
| WarmCaches | A Boolean value that specifies whether the index and reference table are partially loaded into memory before the operation begins. TRUE specifies that the index and reference table are partially loaded into memory before the operation begins. FALSE specifies that the index and reference table are not partially loaded into memory before the operation begins. |

2.7.1.1.1.1.1.2.13 **Import Column Component**

Import Column Component reads data from a file and inserts it into a data flow. Import Column Component MUST NOT have any properties.

2.7.1.1.1.1.1.2.14 **Lookup Component**

Lookup Component looks up values in a table and, based on exact matches only, matches those values to data. Lookup Component MUST NOT use any **Name** attribute value on a **property** element except for those that are listed in the table in this section.

The following table specifies the **Name** attribute values that are allowed for the Lookup Component, in addition to any restrictions on the element value. These restrictions MUST be followed.

| Name attribute value | Description |
|-------------------------------|--|
| SqlCommand | A string value that specifies an SQL SELECT command string that populates the lookup table. |
| SqlCommandParam | A string value that specifies a parameterized SQL statement that populates the lookup table. |
| ConnectionType | An integer value that specifies the connection type. The allowed values are the following: 0 – The connection is OLE DB. 1 – The connection is to a cache. |
| CacheType | An integer value that specifies the cache type for the lookup table. The allowed values are interpreted as follows: 0 – Full. 1 – Partial. 2 – No cache. |
| NoMatchBehavior | An integer value that specifies the behavior when rows with no matching value in the reference dataset are encountered in the data flow. The allowed values are interpreted as follows: 0 – Rows with no matching entries are treated as errors. 1 – Rows with no matching entries are sent to the "no match" output. |
| NoMatchCachePercentage | An integer value between 0 and 100, inclusive, that specifies the maximum percentage of cache memory that can be allocated to data for which a match has not been found. |
| MaxMemoryUsage | An integer value that specifies the maximum memory size in megabytes for the cache on a 32-bit platform. |

| Name attribute value | Description |
|-----------------------------|--|
| MaxMemoryUsage64 | An integer value that specifies the maximum memory size in megabytes for the cache on a 64-bit platform. |
| ReferenceMetadataXml | A string value. <30> |
| ParameterMap | A string value that specifies the parameters that are mapped to the SQL command. The string is delimited by a semicolon. |
| DefaultCodePage | An integer value that specifies the default code page to use if code page information is not available from the data source. |

2.7.1.1.1.1.1.2.15 Merge Component

Merge Component merges, based on values in key columns, two sorted datasets into one output. Merge Component MUST NOT have any properties.

2.7.1.1.1.1.1.2.16 MergeJoin Component

MergeJoin Component merges two sorted tables by using a FULL, LEFT, or INNER join. MergeJoin Component MUST NOT use any **Name** attribute value on a **property** element except for those that are listed in the table in this section.

The following table specifies the **Name** attribute values that are allowed for the MergeJoin Component, in addition to any restrictions on the element value. These restrictions MUST be followed.

| Name attribute value | Description |
|---------------------------|---|
| JoinType | An integer value that specifies the type of join to be performed. The interpretation of the possible values is as follows: 0 – Full join. 1 – Left outer join. 2 – Inner join. |
| NumKeyColumns | An integer value that specifies the number of key columns used in the join. |
| TreatNullsAsEqual | A Boolean value that specifies whether NULL values are treated as equal for the purpose of a join. TRUE specifies that NULL values are treated as equal. FALSE specifies that NULL values are not treated as equal and are treated as they are normally treated by the database server. |
| MaxBuffersPerInput | An integer value that specifies the maximum number of buffers that are used per input. |

2.7.1.1.1.1.1.2.17 Multicast Component

Multicast Component duplicates the input onto all of its outputs. Multicast Component MUST NOT have any properties.

2.7.1.1.1.1.1.2.18 OLE DB Command Component

OLE DB Command Component runs an SQL statement for every row in its data flow. OLE DB Command Component MUST NOT use any **Name** attribute value on a **property** element except for those that are listed in the table in this section.

The following table specifies the **Name** attribute values that are allowed for the OLE DB Command Component, in addition to any restrictions on the element value. These restrictions MUST be followed.

| Name attribute value | Description |
|------------------------|--|
| CommandTimeout | An integer value that specifies the timeout interval, in seconds, for the command. |
| SqlCommand | A string value that specifies the SQL command string. |
| DefaultCodePage | An integer value that specifies the default code page to use if the code page is not available from the data source. |

2.7.1.1.1.1.1.2.19 **Percentage Sampling Component**

Percentage Sampling Component creates a sample data set by randomly selecting a percentage of the transformation input rows. Percentage Sampling Component **MUST NOT** use any **Name** attribute value on a **property** element except for those that are listed in the table in this section.

The following table specifies the **Name** attribute values that are allowed for Percentage Sampling Component, in addition to any restrictions on the element value. These restrictions **MUST** be followed.

| Name attribute value | Description |
|----------------------|---|
| SamplingValue | An integer value that represents the percentage of the source that is taken as a sample. |
| SamplingSeed | An integer value that specifies the random number generator seed that is used for generating a random sample. |

2.7.1.1.1.1.1.2.20 **Pivot Component**

Pivot Component makes a normalized data set into a less normalized but more compact version by pivoting the input data on a column value. Pivot Component **MUST NOT** have any properties.

2.7.1.1.1.1.1.2.21 **RowCount Component**

RowCount Component counts rows in the data flow and stores the result in a variable. RowCount Component **MUST NOT** use any **Name** attribute value on a **property** element except for those that are listed in the table in this section.

The following table specifies the **Name** attribute values that are allowed for RowCount Component, in addition to any restrictions on the element value. These restrictions **MUST** be followed.

| Name attribute value | Description |
|----------------------|--|
| VariableName | A string value that specifies the name of the variable that holds the row count. |

2.7.1.1.1.1.1.2.22 **Row Sampling Component**

Row Sampling Component is used to extract a randomly selected subset of the input data. Row Sampling Component **MUST NOT** use any **Name** attribute value on a **property** element except for those that are listed in the table in this section.

The following table specifies the **Name** attribute values that are allowed for Row Sampling Component, in addition to any restrictions on the element value. These restrictions **MUST** be followed.

| Name attribute value | Description |
|----------------------|---|
| SamplingValue | An integer value that specifies the number of rows in the sample. |
| SamplingSeed | An integer value that specifies the seed value for the random number generator. |

2.7.1.1.1.1.1.2.23 Script Component

Script Component runs custom code that is created in a programming environment within the data flow. Script Component MUST NOT use any **Name** attribute value on a **property** element except for those that are listed in the table in this section.

The following table specifies the **Name** attribute values that are allowed for the Script Component, in addition to any restrictions on the element value. These restrictions MUST be followed.

| Name attribute value | Description |
|------------------------------|---|
| SourceCode | Specifies the source code for the Script Component. The property element value MUST be empty. The SourceCode property element MUST contain the arrayElements element. |
| BinaryCode | Specifies the binary code for the Script Component. The property element value MUST be empty. The BinaryCode property element MUST contain the arrayElements element. |
| VSTAProjectName | A string value that specifies the project name for the Script Component. <31> |
| ScriptLanguage | A string value that specifies the language of the script project. The valid string values are as follows: CSharp -C# language VisualBasic -Visual Basic language |
| ReadOnlyVariables | A string value that specifies the read-only variables in the package that are available to the Script Component. |
| ReadWriteVariables | A string value that specifies the read-write variables in the package that are available to the Script Component. |
| BreakpointCollection | Specifies a collection of breakpoints for the Script Component. The property element value MUST be empty. The BreakpointCollection property element MUST contain the arrayElement element. |
| UserComponentTypeName | A string value that specifies the fully qualified assembly name for the component. |

2.7.1.1.1.1.1.2.24 Slowly Changing Dimension Component

Slowly Changing Dimension Component configures the updating of a slowly changing dimension. Slowly Changing Dimension Component MUST NOT use any **Name** attribute value on a **property** element except for those that are listed in the table in this section.

The following table specifies the **Name** attribute values that are allowed for Slowly Changing Dimension Component, in addition to any restrictions on the element value. These restrictions MUST be followed.

| Name attribute value | Description |
|---------------------------------------|---|
| SqlCommand | A string value that specifies an SQL statement that is used to create a schema rowset. |
| CurrentRowWhere | A string value that specifies a WHERE clause of an SQL SELECT statement that selects the current row among the rows that have the same key value. |
| UpdateChangingAttributeHistory | A Boolean value that specifies whether historical attribute updates are directed to the transformation output for changing attribute updates. |
| FailOnFixedAttributeChange | A Boolean value that specifies whether the transformation fails when rows where the columns with fixed attributes contain changes or when the |

| Name attribute value | Description |
|--------------------------------|---|
| | lookup in the dimension table fails. TRUE specifies that when fixed attributes change or the lookup fails, the operation fails. FALSE specifies that when fixed attributes change or the lookup fails, the operation identifies a new record. |
| InferredMemberIndicator | A string value that specifies the column name for the inferred member . |
| EnableInferredMember | A Boolean value that specifies whether inferred member updates are detected. TRUE specifies that inferred member updates are detected. FALSE specifies that inferred member updates are not detected. |
| FailOnLookupFailure | A Boolean value that specifies whether a lookup failure results in a task failure. TRUE specifies that a lookup failure results in a task failure. FALSE specifies that a lookup failure does not result in a task failure. |
| IncomingRowChangeType | An integer value that specifies the incoming row change type. The allowed values are as follows: 0 – All incoming rows are considered to be new rows. 1 – The system detects which incoming rows are new. |
| DefaultCodePage | An integer value that specifies the default code page to use if code page information is not available from the data source. |

2.7.1.1.1.1.1.2.25 **Sort Component**

Sort Component sorts data. Sort Component MUST NOT use any **Name** attribute value on a **property** element except for those that are listed in the table in this section.

The following table specifies the **Name** attribute values that are allowed for Sort Component, in addition to any restrictions on the element value. These restrictions MUST be followed.

| Name attribute value | Description |
|----------------------------|---|
| EliminateDuplicates | A Boolean value that specifies whether to remove duplicate rows from the output. TRUE specifies that duplicate rows are removed from the output. FALSE specifies that duplicate rows are not removed from the output. |
| MaximumThreads | An integer value that specifies the maximum number of threads to use for sorting. <32> |

2.7.1.1.1.1.1.2.26 **Term Extraction Component**

Term Extraction Component extracts words from text, based on grammatical rules (English language only) to normalize the words. Term Extraction Component MUST NOT use any **Name** attribute value on a **property** element except for those that are listed in the table in this section.

The following table specifies the **Name** attribute values that are allowed for Term Extraction Component, in addition to any restrictions on the element value. These restrictions MUST be followed.

| Name attribute value | Description |
|--------------------------|---|
| NeedReferenceData | A Boolean value that specifies whether a table of excluded terms is used. |

| Name attribute value | Description |
|---------------------------|--|
| | TRUE specifies that a table of excluded terms is used. FALSE specifies that a table of excluded terms is not used. |
| OutTermTable | A string value that specifies the table name that contains the excluded terms. |
| OutTermColumn | A string value that specifies the column name that contains the excluded terms. |
| WordOrPhrase | An integer value that specifies how terms are determined. The valid enumeration values are as follows: 0 – Words only. 1 – Noun phrases only. 2 – Words and noun phrases. |
| ScoreType | An integer value that specifies what type of score is associated with the term. The valid enumeration values are as follows: 0 – The frequency of the term is its score. 1 – The TFIDF Score is the term's score. |
| FrequencyThreshold | An integer value that specifies the number of occurrences of a term before it is extracted. |
| MaxLengthOfTerm | An integer value that specifies the maximum length of terms in characters. It applies only to phrases. |
| IsCaseSensitive | A Boolean value that specifies whether case sensitivity is used when detecting nouns and noun phrases. TRUE specifies that case is used when detecting nouns and noun phrases. FALSE specifies that case is ignored when detecting nouns and noun phrases. |

2.7.1.1.1.1.1.2.27 **Term Lookup Component**

Term Lookup Component looks for a specified set of terms among terms that are extracted by using the same methodology that Term Extraction Component uses. Term Lookup Component **MUST NOT** use any **Name** attribute value on a **property** element except for those that are listed in the table in this section.

The following table specifies the **Name** attribute values that are allowed for Term Lookup Component, in addition to any restrictions on the element value. These restrictions **MUST** be followed.

| Name attribute value | Description |
|------------------------|--|
| RefTermTable | A string value that specifies the name of the table that contains the reference terms. |
| RefTermColumn | A string value that specifies the name of the column that contains the reference terms. |
| IsCaseSensitive | A Boolean value that specifies whether case sensitivity is applied to matching input terms with reference terms. TRUE specifies that case is used when matching input terms with reference terms. FALSE specifies that case is ignored when matching input terms with reference terms. |

2.7.1.1.1.1.1.2.28 **Union All Component**

Union All Component combines multiple inputs into one output stream. Union All Component **MUST NOT** have any properties.

2.7.1.1.1.1.1.2.29 Unpivot Component

Unpivot Component makes an unnormalized dataset into a more normalized version by expanding values from multiple columns in a single record into multiple records with the same values in a single column. Unpivot Component MUST NOT have any properties.

2.7.1.1.1.1.1.2.30 ADO.NET Destination Component

ADO.NET Destination Component loads data into an ADO.NET-compliant database. ADO.NET Destination Component MUST NOT use any **Name** attribute value on a **property** element except for those that are listed in the table in this section.

The following table specifies the **Name** attribute values that are allowed for ADO.NET Destination Component, in addition to any restrictions on the element value. These restrictions MUST be followed.

| Name attribute value | Description |
|------------------------------|---|
| TableOrViewName | A string value that specifies the name of the table or view for the task. |
| BatchSize | An integer value that specifies the number of rows that are sent to the server at a time. <33> |
| CommandTimeout | An integer value that specifies the number of seconds that elapse before the command times out. <34> |
| UserComponentTypeName | A string value that specifies the fully qualified Microsoft .NET Framework assembly name for the component. |

2.7.1.1.1.1.1.2.31 Excel Destination Component

Excel Destination Component writes data to a Microsoft Office Excel workbook. Excel Destination Component MUST NOT use any **Name** attribute value on a **property** element except for those that are listed in the table in this section.

The following table specifies the **Name** attribute values that are allowed for Excel Destination Component, in addition to any restrictions on the element value. These restrictions MUST be followed.

| Name attribute value | Description |
|---------------------------|--|
| CommandTimeout | An integer value that specifies the number of seconds that elapse before the command times out. <35> |
| OpenRowset | A string value that specifies the name of the table or view that is used. This value is used when the AccessMode attribute is set to the value "0" or "3". |
| OpenRowsetVariable | A string value that specifies the name of the variable that contains the name of the table or view that is used. This value is used when the AccessMode attribute is set to the value "1" or "4". |
| SqlCommand | A string value that specifies the SQL command that is used. This value is used when the AccessMode attribute is set to the value "2". |
| AccessMode | An integer value that specifies how to access the database at its destination. The allowed values are as follows: 0 – The name of a table or view is user-specified. 1 – The name of a variable that contains the name of a table or view is specified. 2 – A user-specified SQL statement is used. 3 – Open the rowset with a fast load operation together with a specified table name or view name. 4 – Open the rowset with a fast load operation together with the table name or view |

| Name attribute value | Description |
|------------------------------------|---|
| | name specified in a variable. |
| FastLoadKeepIdentity | A Boolean value that specifies whether to copy identity values during a fast load operation. This value is used if the AccessMode attribute is set to the value "3" or "4". TRUE specifies that identity values are copied. FALSE specifies that identity values are not copied. |
| FastLoadKeepNulls | A Boolean value that specifies whether to copy NULL values during a fast load operation. This value is used if the AccessMode attribute is set to the value "3" or "4". TRUE specifies that NULL values are to be copied. FALSE specifies that NULL values are not to be copied. |
| FastLoadOptions <36> | A string value that specifies the fast load options that are selected. The string is a comma-separated list of fast load options. For more information about fast load options, see [MSDN-PBCO] . |
| FastLoadMaxInsertCommitSize | An integer value that specifies the commit size, in rows, that is used when the AccessMode attribute is set to value "3" or "4". |

2.7.1.1.1.1.1.2.32 **Flat File Destination Component**

Flat File Destination Component writes data to a flat file. Flat File Destination Component MUST NOT use any **Name** attribute value on a **property** element except for those that are listed in the table in this section.

The following table specifies the **Name** attribute values that are allowed for Flat File Destination Component, in addition to any restrictions on the element value. These restrictions MUST be followed.

| Name attribute value | Description |
|----------------------|---|
| Header | A string value that contains a string that is inserted into the file header before data is written to the file. |
| Overwrite | A Boolean value that specifies whether to overwrite or to append to an existing destination file that has the same name. TRUE specifies to overwrite a destination file that has the same name. FALSE specifies to append to a destination file that has the same name. |

2.7.1.1.1.1.1.2.33 **OLE DB Destination Component**

OLE DB Destination Component loads data into an OLE DB-compliant database. OLE DB Destination Component MUST NOT use any **Name** attribute value on a **property** element except for those that are listed in the table in this section.

The following table specifies the **Name** attribute values that are allowed for OLE DB Destination Component, in addition to any restrictions on the element value. These restrictions MUST be followed.

| Name attribute value | Description |
|-----------------------|---|
| CommandTimeout | An integer value that specifies the number of seconds that elapse before the command times out.<37> |
| OpenRowset | A string value that specifies the name of the table or view that is used. This value is used when the AccessMode attribute is set to the value "0" or "3". |

| Name attribute value | Description |
|------------------------------------|---|
| OpenRowsetVariable | A string value that specifies the name of the variable that contains the name of the table or view that is used. This value is used when the AccessMode attribute is set to the value "1" or "4". |
| SqlCommand | A string value that specifies the SQL command that is used. This value is used when the AccessMode attribute is set to value "2". |
| DefaultCodePage | An integer value that specifies the default code page to use if code page information is not available from the data source. |
| AlwaysUseDefaultCodePage | A Boolean value that specifies whether to always use the value for the code page given in the DefaultCodePage attribute. TRUE specifies to always use the value that is given in the DefaultCodePage attribute for the code page value. FALSE specifies to first try to derive the code page value from the data source. If the code page value cannot be derived from the data source, the DefaultCodePage attribute value is used. |
| AccessMode | An integer value that specifies how to access the database at its destination. The allowed values are as follows: 0 – The name of a table or view is user-specified. 1 – The name of a variable that contains the name of a table or view is specified. 2 – A user-specified SQL statement is used. 3 –The rowset is opened by using a fast load operation, with a specified table name or view name. 4 –The rowset is opened by using a fast load operation, with the table name or view name that is specified in a variable. |
| FastLoadKeepIdentity | A Boolean value that specifies whether to copy identity values during a fast load operation. This value is used if the AccessMode attribute is set to the value "3" or "4". TRUE specifies that identity values are copied. FALSE specifies that identity values are not copied. |
| FastLoadKeepNulls | A Boolean value that specifies whether to copy NULL values during a fast load operation. This value is used if the AccessMode attribute is set to the value "3" or "4". TRUE specifies that NULL values are to be copied. FALSE specifies that NULL values are not to be copied. |
| FastLoadOptions | A string value that specifies the fast load options that are selected. The string is a comma-separated list of fast load options. For more information about fast load options, see [MSDN-PBCO].<38> |
| FastLoadMaxInsertCommitSize | An integer value that specifies the commit size, in rows, that is used when AccessMode is set to value "3" or "4". |

2.7.1.1.1.1.1.2.34 **DataReader Destination Component**

DataReader Destination Component exposes the data in a data flow by using the ADO.NET DataReader interface. The data can then be consumed by other applications. DataReader Destination Component MUST NOT use any **Name** attribute value on a **property** element except for those that are listed in the table in this section.

The following table specifies the **Name** attribute values that are allowed for DataReader Destination Component, in addition to any restrictions on the element value. These restrictions MUST be followed.

| Name attribute value | Description |
|------------------------------|---|
| ReadTimeout | An integer value that specifies the number of milliseconds that elapse before the operation times out. |
| DataReader | A string value that specifies the class name of the data reader object at the destination. |
| FailOnTimeout | A Boolean value that specifies whether to fail if the value for the ReadTimeout attribute is reached. TRUE specifies to fail if the ReadTimeout attribute value is reached. FALSE specifies not to fail if the ReadTimeout attribute value is reached. |
| UserComponentTypeName | A string value that specifies the fully qualified .NET Framework assembly name for the component. |

2.7.1.1.1.1.1.2.35 **Data Mining Model Training Destination Component**

Data Mining Model Training Destination Component applies data mining model training algorithms to the data that it receives from the data flow. Data Mining Model Training Destination Component MUST NOT use any **Name** attribute value on a **property** element except for those that are listed in the table in this section.

The following table specifies the **Name** attribute values that are allowed for Data Mining Model Training Destination Component, in addition to any restrictions on the element value. These restrictions MUST be followed.

| Name attribute value | Description |
|----------------------|---|
| ObjectRef | A string value that specifies an XML tag that identifies the mining structure that the task uses. |

2.7.1.1.1.1.1.2.36 **Dimension Processing Destination Component**

Dimension Processing Destination Component loads and processes an Analysis Services dimension. Dimension Processing Destination Component MUST NOT use any **Name** attribute value on a **property** element except for those that are listed in the table in this section.

The following table specifies the **Name** attribute values that are allowed for Dimension Processing Destination Component, in addition to any restrictions on the element value. These restrictions MUST be followed.

| Name attribute value | Description |
|--------------------------------|--|
| ObjectRef | A string value that contains a reference to an Analysis Management Objects (AMO) object that represents the dimension, after it is looked up. <39> |
| UseDefaultConfiguration | A Boolean value that specifies whether to use the existing default configuration on the server. TRUE specifies to use the existing default configuration on the server. FALSE specifies to not use the default configuration on the server. If the value is FALSE, the value that is used is specified in the values of the properties of the component. |
| KeyErrorLimit | An integer value that specifies the number of key errors after which processing fails. This value is used only if the UseDefaultConfiguration attribute value is set to FALSE. |
| KeyErrorLogFile | A string value that specifies the file path to the file that is used to log key |

| Name attribute value | Description |
|----------------------------------|--|
| | errors. This value is used only if the UseDefaultConfiguration attribute value is set to FALSE. |
| KeyErrorAction | An integer value that specifies the action to take upon encountering a key processing error. The allowed values are the following: 0 – Convert the key to the "unknown" value. 1 – Discard the record. This value is used only if the UseDefaultConfiguration attribute value is set to FALSE. |
| KeyErrorLimitAction | An integer value that specifies the action to take upon reaching the key error limit. The allowed values are the following: 0 – Stop processing. 1 – Continue processing and stop logging. This value is used only if the UseDefaultConfiguration attribute value is set to FALSE. |
| KeyNotFound | An integer value that specifies the action to take if a key is not found. The allowed values are the following: 0 – Ignore the error. 1 – Report the error and continue. 2 – Report the error and stop processing. This value is used only if the UseDefaultConfiguration attribute value is set to FALSE. |
| KeyDuplicate | An integer value that specifies the action to take if a duplicate key is found. The allowed values are the following: 0 – Ignore the error. 1 – Report the error and continue. 2 – Report the error and stop processing. This value is used only if the UseDefaultConfiguration attribute value is set to FALSE. |
| NullKeyConvertedToUnknown | An integer value that specifies the action to take if a null key is found and converted to "unknown". The allowed values are the following: 0 – Ignore the error. 1 – Report the error and continue. 2 – Report the error and stop processing. This value is used only if the UseDefaultConfiguration attribute value is set to FALSE. |
| NullKeyNotAllowed | An integer value that specifies the action to take if a null key is found that is not allowed. The allowed values are the following: 0 – Ignore the error. 1 – Report the error and continue. 2 – Report the error and stop processing. This value is used only if the UseDefaultConfiguration attribute value is set to FALSE. |
| ProcessType | An integer value that specifies the type of processing that is performed on the |

| Name attribute value | Description |
|----------------------|---|
| | dimension. The allowed values are the following: <40> 0 – Full processing. 1 – Processing to add to dimension. 2 – Update processing. |

2.7.1.1.1.1.1.2.37 **Partition Processing Destination Component**

Partition Processing Destination Component loads and processes an Analysis Services partition. Partition Processing Destination Component MUST NOT use any **Name** attribute value on a **property** element except for those that are listed in the table in this section.

The following table specifies the **Name** attribute values that are allowed for Partition Processing Destination Component, in addition to any restrictions on the element value. These restrictions MUST be followed.

| Name attribute value | Description |
|--------------------------------|---|
| ObjectRef | A string value that contains a reference to an Analysis Management Objects (AMO) object that represents the partition, after it is looked up. <41> |
| UseDefaultConfiguration | A Boolean value that specifies whether to use the existing default configuration on the server. TRUE specifies to use the existing default configuration on the server. FALSE specifies to not use the default configuration on the server. If the value is FALSE, the values that are used are specified in the values of the properties of the component. |
| KeyErrorLimit | An integer value that specifies the number of key errors after which processing fails. This value is used only if the UseDefaultConfiguration attribute value is set to FALSE. |
| KeyErrorLogFile | A string value that specifies the file path to the file that is used to log key errors. This value is used only if the UseDefaultConfiguration attribute value is set to FALSE. |
| KeyErrorAction | An integer value that specifies the action to take upon encountering a key processing error. The allowed values are the following: 0 – Convert the key to the "unknown" value. 1 – Discard the record. This value is used only if the UseDefaultConfiguration attribute value is set to FALSE. |
| KeyErrorLimitAction | An integer value that specifies the action to take upon reaching the key error limit. The allowed values are the following: 0 – Stop processing. 1 – Continue processing and stop logging. This value is used only if the UseDefaultConfiguration attribute value is set to FALSE. |
| KeyNotFound | An integer value that specifies the action to take if a key is not found. The allowed values are the following: 0 – Ignore the error. 1 – Report the error and continue. |

| Name attribute value | Description |
|----------------------------------|--|
| | 2 – Report the error and stop processing. This value is used only if the UseDefaultConfiguration attribute value is set to FALSE. |
| KeyDuplicate | An integer value that specifies the action to take if a duplicate key is found. The allowed values are the following: 0 – Ignore the error. 1 – Report the error and continue. 2 – Report the error and stop processing. This value is used only if the UseDefaultConfiguration attribute value is set to FALSE. |
| NullKeyConvertedToUnknown | An integer value that specifies the action to take if a null key is found and converted to "unknown". The allowed values are the following: 0 – Ignore the error. 1 – Report the error and continue. 2 – Report the error and stop processing. This value is used only if the UseDefaultConfiguration attribute value is set to FALSE. |
| NullKeyNotAllowed | An integer value that specifies the action to take if a null key is found that is not allowed. The allowed values are the following: 0 – Ignore the error. 1 – Report the error and continue. 2 – Report the error and stop processing. This value is used only if the UseDefaultConfiguration attribute value is set to FALSE. |
| ProcessType | An integer value that specifies the type of processing that is performed on the dimension. The allowed values are the following: <42> 0 – Full processing. 1 – Processing to add to dimension. 2 – Update processing. |

2.7.1.1.1.1.1.2.38 **Raw File Destination Component**

Raw File Destination Component writes raw data to a file in a format that is native to the file type. Raw File Destination Component MUST NOT use any **Name** attribute value on a **property** element except for those that are listed in the table in this section.

The following table specifies the **Name** attribute values that are allowed for Raw File Destination Component, in addition to any restrictions on the element value. These restrictions MUST be followed.

| Name attribute value | Description |
|----------------------|---|
| AccessMode | An integer value that specifies whether the file is specified in the XML or is specified as the value of a variable. The allowed values are the following: 0 – The file name is specified in the XML. 1 – The file name is specified as the value of a variable. |

| Name attribute value | Description |
|-------------------------|--|
| FileName | A string value that specifies the name of the file for output. This value is used only if the value of the AccessMode attribute is "0". |
| FileNameVariable | A string value that specifies the name of the variable that contains the file name for the output file. This value applies only if the value for the AccessMode attribute is equal to "1". |
| WriteOption | An integer value that specifies the action to take for the file write operation. The allowed values are the following: 0 – Always create the file. 1 – Create the file one time only. 2 – Append to an existing file. 3 – Truncate the file and append. |

2.7.1.1.1.1.1.2.39 RecordSet Destination Component

RecordSet Destination Component creates and populates an in-memory ADO recordset. RecordSet Destination Component MUST NOT use any **Name** attribute value on a **property** element except for those that are listed in the table in this section.

The following table specifies the **Name** attribute values that are allowed for RecordSet Destination Component, in addition to any restrictions on the element value. These restrictions MUST be followed.

| Name attribute value | Description |
|----------------------|--|
| VariableName | A string value that specifies the name of the variable that holds the ADO recordset. |

2.7.1.1.1.1.1.2.40 SQL Server Compact Edition Destination Component

SQL Server Compact Edition Destination Component loads data into a SQL Server Compact Edition database. SQL Server Compact Edition Destination Component MUST NOT use any **Name** attribute value on a **property** element except for those that are listed in the table in this section.

The following table specifies the **Name** attribute values that are allowed for SQL Server Compact Edition Destination Component, in addition to any restrictions on the element value. These restrictions MUST be followed.

| Name attribute value | Description |
|------------------------------|---|
| TableName | A string value that specifies the name of the destination table in the SQL Server Compact Edition database. |
| UserComponentTypeName | A string value that specifies the fully qualified .NET Framework assembly name for the component. |

2.7.1.1.1.1.1.2.41 SQL Server Destination Component

SQL Server Destination Component connects to a local SQL Server database and bulk loads data into SQL Server tables and views on a server that is local to where the package is executing. SQL Server Destination Component MUST NOT use any **Name** attribute value on a **property** element except for those that are listed in the table in this section.

The following table specifies the **Name** attribute values that are allowed for SQL Server Destination Component, in addition to any restrictions on the element value. These restrictions MUST be followed.

| Name attribute value | Description |
|-----------------------------------|---|
| DefaultCodePage | An integer value that specifies the default code page to use if code page information is not available from the data source. |
| AlwaysUseDefaultCodePage | A Boolean value that specifies whether to always use the value for the code page that is given in the DefaultCodePage attribute. TRUE specifies to always use the value that is given in the DefaultCodePage attribute for the code page value. FALSE specifies to first try to derive the code page value from the data source. If the code page value cannot be derived from the data source, the DefaultCodePage attribute value is used. |
| BulkInsertTableName | A string value that specifies the table name to use for the bulk insert operation. |
| BulkInsertCheckConstraints | A Boolean value that specifies whether constraints on the table are checked during the bulk insert operation. TRUE specifies that constraints are checked. FALSE specifies that constraints are not checked. |
| BulkInsertFirstRow | An integer value that specifies the row in the table at which insertion begins. <43> |
| BulkInsertFireTriggers | A Boolean value that specifies whether insert triggers that are specified for the table are fired during the bulk insert operation. TRUE specifies that triggers are fired during the bulk insert operation. FALSE specifies that triggers are not fired during the bulk insert operation. |
| BulkInsertKeepIdentity | A Boolean value that specifies whether to keep data values from the data file for values for identity columns. TRUE specifies that the values that are present in the data file are kept for identity columns. FALSE specifies that the values that are present in the data file for identity columns are not kept. |
| BulkInsertKeepNulls | A Boolean value that specifies whether null values in the input are retained. TRUE specifies that null values in the input are retained. FALSE specifies that a default value is used if a null value is encountered in the input. |
| BulkInsertLastRow | An integer value that specifies the row in the data file at which insertion ends. <44> |
| BulkInsertMaximumErrors | An integer value that specifies the maximum number of errors that are allowed. |
| BulkInsertOrder | A string value that specifies the columns that are used for sorting. |
| BulkInsertTablock | A Boolean value that specifies whether a table level lock is acquired for the bulk insert operation. TRUE specifies that a table level lock is acquired for the bulk insert operation. FALSE specifies that a table level lock is not acquired for the bulk insert operation. |
| Timeout | An integer value that specifies the number of seconds that the destination waits for records to insert before the operation times out. <45> |
| MaxInsertCommitSize | An integer value that specifies the maximum number of rows to insert in a single batch. <46> |

2.7.1.1.1.1.1.2.42 ADO.NET Source Component

ADO.NET Source Component accepts data from an ADO.NET-compliant database as its source of data. ADO.NET Source Component MUST NOT use any **Name** attribute value on a **property** element except for those that are listed in the table in this section.

The following table specifies the **Name** attribute values that are allowed for ADO.NET Source Component, in addition to any restrictions on the element value. These restrictions MUST be followed.

| Name attribute value | Description |
|--------------------------------------|---|
| SqlCommand | A string value that specifies an SQL SELECT command string that populates the lookup table. |
| CommandTimeout | An integer value that specifies the number of seconds that elapse before the command times out. <47> |
| AllowImplicitStringConversion | A Boolean value that specifies whether external metadata types are converted to the type that the destination requires. TRUE specifies that external types are converted to strings. FALSE specifies that no error is generated if there is a mismatch between the external metadata type and a column that requires a string. <48> |
| TableOrViewName | A string value that specifies the name of the table or view for the task. |
| AccessMode | An integer value that specifies the access mode to the ADO.NET data. The allowed values are the following: 0 – Table or view. 2 – SQL command. |
| UserComponentTypeName | A string value that specifies the fully qualified .NET Framework assembly name for the component. |

2.7.1.1.1.1.1.2.43 **Excel Source Component**

Excel Source Component accepts data from an Office Excel workbook as its source of data. Excel Source Component MUST NOT use any **Name** attribute value on a **property** element except for those that are listed in the table in this section.

The following table specifies the **Name** attribute values that are allowed for Excel Source Component, in addition to any restrictions on the element value. These restrictions MUST be followed.

| Name attribute value | Description |
|---------------------------|--|
| CommandTimeout | An integer value that specifies the number of seconds that elapse before the command times out. <49> |
| OpenRowset | A string value that specifies the name of the table or view that is used. This value is used when the AccessMode attribute is set to the value "0" or "3". |
| OpenRowsetVariable | A string value that specifies the name of the variable that contains the name of the table or view that is used. This value is used when the AccessMode attribute is set to the value "1" or "4". |
| SqlCommand | A string value that specifies the SQL command that is used. This value is used when the AccessMode attribute is set to the value "2". |
| SqlCommandVariable | A string value that specifies the name of the variable that contains the SQL command that is executed. |
| AccessMode | An integer value that specifies how to access the data in the Office Excel sheet. |

| Name attribute value | Description |
|-------------------------|--|
| | The allowed values are the following: 0 – Use "open rowset" to open the Office Excel data. 1 – Use "open rowset" from the value that is contained in a variable to open the Office Excel data. 2 – Use an SQL command to open the Office Excel data. 3 – Use an SQL command that is contained in a variable to open the Office Excel data. |
| ParameterMapping | A string value that specifies the mapping of SQL parameters to values that are contained in variables. |

2.7.1.1.1.1.1.2.44 **Flat File Source Component**

Flat File Source Component accepts data from a flat file as its source of data. Flat File Source Component MUST NOT use any **Name** attribute value on a **property** element except for those that are listed in the table in this section.

The following table specifies the **Name** attribute values that are allowed for Flat File Source Component, in addition to any restrictions on the element value. These restrictions MUST be followed.

| Name attribute value | Description |
|---------------------------|--|
| RetainNulls | A Boolean value that specifies whether to retain NULL values that are obtained from the source during the pipeline processing. TRUE specifies that NULL values are retained during pipeline processing. FALSE specifies that NULL values are not retained. |
| FileNameColumnName | A string value that specifies the name of the output column that contains the file name for the flat file source file. |

2.7.1.1.1.1.1.2.45 **OLE DB Source Component**

OLE DB Source Component accepts data from an OLE DB-compliant database as its source of data. OLE DB Source Component MUST NOT use any **Name** attribute value on a **property** element except for those that are listed in the table in this section.

The following table specifies the **Name** attribute values that are allowed for OLE DB Source Component, in addition to any restrictions on the element value. These restrictions MUST be followed.

| Name attribute value | Description |
|---------------------------------|--|
| CommandTimeout | An integer value that specifies the number of seconds that elapse before the command times out. <50> |
| OpenRowset | A string value that specifies the name of the table or view that is used. This value is used when the AccessMode attribute is set to the value "0" or "3". |
| OpenRowsetVariable | A string value that specifies the name of the variable that contains the name of the table or view that is used. This value is used when the AccessMode attribute is set to the value "1" or "4". |
| SqlCommand | A string value that specifies the SQL command that is used. This value is used when the AccessMode attribute is set to value "2". |
| DefaultCodePage | An integer value that specifies the default code page to use if code page information is not available from the data source. |
| AlwaysUseDefaultCodePage | A Boolean value that specifies whether to always use the value for the code page given in the DefaultCodePage attribute. |

| Name attribute value | Description |
|-------------------------|--|
| | TRUE specifies to always use the value given in the DefaultCodePage attribute for the code page value. FALSE specifies to first try to derive the code page value from the data source. If the code page value cannot be derived from the data source, the DefaultCodePage attribute value is used. |
| AccessMode | An integer value that specifies how to access the data in the Microsoft Office Excel sheet. The allowed values are the following: 0 – Use "open rowset" to open the Office Excel data. 1 – Use "open rowset" from the value that is contained in a variable to open the Office Excel data. 2 – Use an SQL command to open the Office Excel data. 3 – Use an SQL command that is contained in a variable to open the Office Excel data. |
| ParameterMapping | A string value that specifies the mapping of SQL parameters to values that are contained in variables. |

2.7.1.1.1.1.1.2.46 **Raw File Source Component**

Raw File Source Component accepts data from a raw file as its source of data. Raw File Source Component MUST NOT use any **Name** attribute value on a **property** element except for those that are listed in the table in this section.

The following table specifies the **Name** attribute values that are allowed for Raw File Source Component, in addition to any restrictions on the element value. These restrictions MUST be followed.

| Name attribute value | Description |
|-------------------------|--|
| AccessMode | An integer value that specifies whether the file is specified in the XML or is specified as the value of a variable. The allowed values are the following: 0 – File name is specified in the package file. 1 – File name is specified as the value of a variable. |
| FileName | A string value that specifies the name of the file for output. This value is used only if the value of the AccessMode attribute is "0". |
| FileNameVariable | A string value that specifies the name of the variable that contains the file name for the output file. This value applies only if the value for the AccessMode attribute is equal to "1". |

2.7.1.1.1.1.1.2.47 **XML Source Component**

XML Source Component accepts data from an XML file as its source of data. XML Source Component MUST NOT use any **Name** attribute value on a **property** element except for those that are listed in the table in this section.

The following table specifies the **Name** attribute values that are allowed for XML Source Component, in addition to any restrictions on the element value. These restrictions MUST be followed.

| Name attribute value | Description |
|------------------------------|---|
| UserComponentTypeName | A string value that specifies the fully qualified .NET Framework assembly name for the component. |

| Name attribute value | Description |
|----------------------------|--|
| XMLData | A string value that specifies the file name or variable name that contains the XML. The content of the string is dependent upon the value of the AccessMode attribute. |
| XMLDataVariable | A string value that specifies the name of the variable that contains the XML data. |
| AccessMode | An integer value that specifies the mode of access of the XML. The allowed values are the following: 0 – XML file. 1 - XML file from the value of a variable. 2 – XML data from the value of a variable. |
| XMLSchemaDefinition | A string value that contains an inline XML Schema definition. This value is used only if the UseInlineSchema attribute value is set to TRUE. |
| UseInlineSchema | A Boolean value that specifies whether an inline XML Schema definition is used. TRUE specifies that an inline XML Schema definition is used. FALSE specifies that an inline XML Schema definition is not used. |

2.7.1.1.1.1.1.3 PipelineComponentDataTypeEnum

The **PipelineComponentDataTypeEnum** type contains the enumeration values for the **dataType** attribute.

The following is the XSD for the **PipelineComponentDataTypeEnum** type.

```
<xs:simpleType name="PipelineComponentDataTypeEnum">
  <xs:restriction base="xs:string">
    <xs:enumeration value="System.Boolean"/>
    <xs:enumeration value="System.Byte"/>
    <xs:enumeration value="System.SByte"/>
    <xs:enumeration value="System.Decimal"/>
    <xs:enumeration value="System.Double"/>
    <xs:enumeration value="System.Single"/>
    <xs:enumeration value="System.Int32"/>
    <xs:enumeration value="System.UInt32"/>
    <xs:enumeration value="System.Int64"/>
    <xs:enumeration value="System.UInt64"/>
    <xs:enumeration value="System.Int16"/>
    <xs:enumeration value="System.UInt16"/>
    <xs:enumeration value="System.String"/>
    <xs:enumeration value="System.Null"/>
    <xs:enumeration value="System.DateTime"/>
    <xs:enumeration value="System.Object"/>
  </xs:restriction>
</xs:simpleType>
```

The following table specifies the enumeration values for the **PipelineComponentDataTypeEnum** type.

| Enumeration value | Description |
|-----------------------|-------------------------|
| System.Boolean | The value is a Boolean. |
| System.Byte | The value is a byte. |

| Enumeration value | Description |
|------------------------|--|
| System.SByte | The value is an 8-bit signed integer. |
| System.Decimal | The value is a decimal quantity. |
| System.Double | The value is a double precision real number. |
| System.Single | The value is a single precision real number. |
| System.Int32 | The value is a 32-bit integer. |
| System.UInt32 | The value is a 32-bit unsigned integer. |
| System.Int64 | The value is a 64-bit integer. |
| System.UInt64 | The value is a 64-bit unsigned integer. |
| System.Int16 | The value is a 16-bit integer. |
| System.UInt16 | The value is a 16-bit unsigned integer. |
| System.String | The value is a string. |
| System.Null | The value is null. |
| System.DateTime | The value is a date-time value. |
| System.Object | The value is an object. |

2.7.1.1.1.1.1.4 PipelineComponentStateEnum

The **PipelineComponentStateEnum** type contains the enumeration values for the **state** attribute.

The following is the XSD for the **PipelineComponentStateEnum** type.

```
<xs:simpleType name="PipelineComponentStateEnum">
  <xs:restriction base="xs:string">
    <xs:enumeration value="cdata"/>
    <xs:enumeration value="escaped"/>
    <xs:enumeration value="default"/>
  </xs:restriction>
</xs:simpleType>
```

The following table specifies the enumeration values for the **PipelineComponentStateEnum** type.

| Enumeration value | Description |
|-------------------|---|
| cdata | Serialize the property value as a CDATA XSD section. |
| escaped | Serialize the property value as text, with escape sequence as needed. |
| default | Serialize the property value in the default fashion. |

2.7.1.1.1.1.1.5 PipelineComponentExpressionTypeEnum

The **PipelineComponentExpressionTypeEnum** type contains the enumeration values for the **expressionType** attribute.

The following is the XSD for the **PipelineComponentExpressionTypeEnum** type.

```
<xs:simpleType name="PipelineComponentExpressionTypeEnum">
  <xs:restriction base="xs:string">
    <xs:enumeration value="None"/>
    <xs:enumeration value="Notify"/>
  </xs:restriction>
</xs:simpleType>
```

The following table specifies the enumeration values for the **PipelineComponentExpressionTypeEnum** type.

| Enumeration value | Description |
|-------------------|--|
| None | The value of the property cannot be specified with an expression. |
| Notify | The value of the property can be specified with a property expression. |

2.7.1.1.1.1.2 PipelineComponentConnectionsType

The **PipelineComponentConnectionsType** type specifies a collection of connection objects for a component.

The following is the XSD for the **PipelineComponentConnectionsType** type.

```
<xs:complexType name="PipelineComponentConnectionsType">
  <xs:sequence>
    <xs:element name="connection" form="unqualified"
      type="DTS:PipelineComponentConnectionType"
      minOccurs="0" maxOccurs="unbounded"/>
  </xs:sequence>
</xs:complexType>
```

The following table specifies the elements of the **PipelineComponentConnectionsType** type.

| Element | Type definition | Description |
|-------------------|---|--|
| connection | PipelineComponentConnectionType | A complex type that specifies a reference to a connection manager that is available to this component. |

2.7.1.1.1.1.2.1 PipelineComponentConnectionType

The **PipelineComponentConnectionType** type specifies a collection of connection objects for a component.

The following is the XSD for the **PipelineComponentConnectionType** type.

```
<xs:complexType name="PipelineComponentConnectionType">
  <xs:sequence/>
  <xs:attribute name="id" type="xs:int" form="unqualified"/>
  <xs:attribute name="name" type="xs:string" form="unqualified"/>
</xs:complexType>
```

```

<xs:attribute name="description" type="xs:string"
              form="unqualified"/>
<xs:attribute name="connectionManagerID" type="DTS:uuid"
              form="unqualified"/>
</xs:complexType>

```

The following table specifies the attributes of the **PipelineComponentConnectionType** type.

| Attribute | Description |
|----------------------------|---|
| id | An integer value that specifies the identifier for this component connection element. Other elements can refer to this component connection element by using this PipelineComponentConnectionType value. |
| name | A string value that specifies the name for this component connection element. |
| description | A string value that specifies the description for this component connection element. |
| connectionManagerID | A universally unique identifier (UUID) value that specifies the DTSID attribute of the connection manager that is used by this component connection. |

2.7.1.1.1.1.3 PipelineComponentInputsType

The **PipelineComponentInputsType** type specifies a collection of output objects for a component.

The following is the XSD for the **PipelineComponentInputsType** type.

```

<xs:complexType name="PipelineComponentInputsType">
  <xs:sequence>
    <xs:element name="input" form="unqualified"
                type="DTS:PipelineComponentInputType"
                minOccurs="0" maxOccurs="unbounded"/>
  </xs:sequence>
</xs:complexType>

```

The following table specifies the elements of the **PipelineComponentInputsType** type.

| Element | Type definition | Description |
|--------------|--|--|
| input | PipelineComponentInputType | A complex type that specifies a reference to an input that is available to this component. |

2.7.1.1.1.1.3.1 PipelineComponentInputType

The **PipelineComponentInputType** type specifies the structure in which the descriptor for a single input to a component is held. All inputs are not identical, so this general structure is designed to hold the variety of inputs that a component can have.

The following is the XSD for the **PipelineComponentInputType** type.

```

<xs:complexType name="PipelineComponentInputType">
  <xs:sequence>
    <xs:element name="inputColumns"
                type="DTS:PipelineComponentInputColumnsType"
                minOccurs="0" form="unqualified"/>
  </xs:sequence>
</xs:complexType>

```

```

    <xs:element name="externalMetadataColumns"
      type="DTS:PipelineComponentMetadataColumnsType"
      minOccurs="0" form="unqualified"/>
  </xs:sequence>
  <xs:attributeGroup
    ref="DTS:PipelineComponentInputOutputElementAttributeGroup"/>
</xs:complexType>

```

The following table specifies the elements of the **PipelineComponentInputType** type.

| Element | Type definition | Description |
|--------------------------------|--|--|
| inputColumns | PipelineComponentInputColumnsType | A complex type that specifies a collection of input columns that are associated with the input element. |
| externalMetadataColumns | PipelineComponentMetadataColumnsType | A complex type that specifies a collection of external metadata columns that are associated with the input element. |

The following table specifies the attribute groups of the **PipelineComponentInputType** type.

| Attribute | Description |
|--|---|
| PipelineComponentInputOutputElementAttributeGroup | An attribute group specification that specifies attributes that are common for the input element and for the output element of the PipelineComponentOutputType type. |

2.7.1.1.1.3.1.1 PipelineComponentInputColumnsType

The **PipelineComponentInputColumnsType** type specifies a collection of column objects for an **input** element that is part of a Pipeline component.

The following is the XSD for the **PipelineComponentInputColumnsType** type.

```

<xs:complexType name="PipelineComponentInputColumnsType">
  <xs:sequence>
    <xs:element name="inputColumn"
      type="DTS:PipelineComponentInputColumnType"
      minOccurs="0" maxOccurs="unbounded" form="unqualified"/>
  </xs:sequence>
</xs:complexType>

```

The following table specifies the elements of the **PipelineComponentInputColumnsType** type.

| Element | Type definition | Description |
|--------------------|--|--|
| inputColumn | PipelineComponentInputColumnType | A complex type that specifies a single column within a pipeline input. |

2.7.1.1.1.3.1.2 PipelineComponentInputColumnType

The **PipelineComponentInputColumnType** type specifies a single column that is a member of a collection of input columns to a Pipeline component.

The following is the XSD for the **PipelineComponentInputColumnType** type.

```
<xs:complexType name="PipelineComponentInputColumnType">
  <xs:sequence>
    <xs:element name="properties"
      type="DTS:PipelineComponentInputColumnPropertiesType"
      form="unqualified" minOccurs="0" maxOccurs="unbounded"/>
  </xs:sequence>
  <xs:attributeGroup
    ref="DTS:PipelineComponentAllColumnBaseAttributeGroup"/>
  <xs:attributeGroup
    ref="DTS:PipelineComponentIOColumnBaseAttributeGroup"/>
  <xs:attribute name="usageType" form="unqualified"
    type="DTS:PipelineComponentUsageTypeEnum"/>
</xs:complexType>
```

The following table specifies the elements of the **PipelineComponentInputColumnType** type.

| Element | Type definition | Description |
|-------------------|--|--|
| properties | PipelineComponentInputColumnPropertiesType | A complex type that specifies a collection of properties of an input column. |

The following table specifies the attributes and attribute groups of the **PipelineComponentInputColumnType** type.

| Attribute group | Description |
|---|---|
| PipelineComponentAllColumnBaseAttributeGroup | An attribute group specification that specifies attributes that are common to all types of columns for Pipeline components. |
| PipelineComponentIOColumnBaseAttributeGroup | An attribute group specification that specifies attributes that are common to all input and output columns for Pipeline components. |
| usageType | An enumeration value that specifies the type of use available for the input column. |

2.7.1.1.1.3.1.3 PipelineComponentInputColumnPropertiesType

The **PipelineComponentInputColumnPropertiesType** type specifies a collection of properties for an **inputColumn** element that is part of a Pipeline component.

The following is the XSD for the **PipelineComponentInputColumnPropertiesType** type.

```
<xs:complexType name="PipelineComponentInputColumnPropertiesType">
  <xs:sequence>
    <xs:element name="property" form="unqualified"
      type="DTS:PipelineComponentInputColumnPropertyType"
      minOccurs="0" maxOccurs="unbounded"/>
  </xs:sequence>
</xs:complexType>
```

The following table specifies the elements of the **PipelineComponentInputColumnPropertiesType** type.

| Element | Type definition | Description |
|-----------------|--|---|
| property | PipelineComponentInputColumnPropertyType | A complex type that specifies a single property within a collection of input column properties for an inputColumn element of a Pipeline component. |

2.7.1.1.1.1.3.1.3.1 PipelineComponentInputColumnPropertyType

The **PipelineComponentInputColumnPropertyType** type specifies a property of an **inputColumn** element.

The following is the XSD for the **PipelineComponentInputColumnPropertyType** type.

```
<xs:complexType name="PipelineComponentInputColumnPropertyType">
  <xs:simpleContent>
    <xs:extension base="xs:anySimpleType">
      <xs:attributeGroup
        ref="DTS:PipelineComponentPropertyAttributeGroup"/>
      <xs:attribute name="name" form="unqualified"
        type="DTS:PipelineComponentInputColumnPropertyNameEnum"/>
    </xs:extension>
  </xs:simpleContent>
</xs:complexType>
```

The following table specifies the attributes and attribute groups of the **PipelineComponentInputColumnPropertyType** type.

| Attribute | Description |
|--|---|
| PipelineComponentPropertyAttributeGroup | An attribute group that contains attributes that are common to all property elements for input elements, output elements, inputColumn elements, and outputColumn elements. |
| name | A string value that specifies the name of the property |

2.7.1.1.1.1.3.1.3.1.1 PipelineComponentInputColumnPropertyNameEnum

The **PipelineComponentInputColumnPropertyNameEnum** type contains the allowed values for the **name** attribute on the **inputColumn** element of a Pipeline component. The allowed values for the property element for each task are more restricted than the values that are specified formally by the XSD.

Each **name** attribute value MUST NOT be used for any component except for the components that are specified in the subsections to this section. Some components allow no properties.

The additional restrictions specified in the subsections to this section MUST be followed for the **name** attribute on the **property** element children of the **inputColumn** element.

The following is the XSD for the **PipelineComponentInputColumnPropertyNameEnum** type.

```
<xs:simpleType name="PipelineComponentInputColumnPropertyNameEnum">
  <xs:restriction base="xs:string">
    <!--Transforms-->
    <!--Aggregate Task-->
    <!--Audit (none)-->
    <!--Cache Transform-->
  </xs:restriction>
</xs:simpleType>
```

```

<xs:enumeration value="CacheColumnName"/>
<!--Character Map-->
<xs:enumeration value="MapFlags"/>
<!--Conditional Split (none)-->
<!--Copy Column (none)-->
<!--Data Conversion (none)-->
<!--Data Mining Query(none)-->
<!--Derived Column Query-->
<xs:enumeration value="Expression"/>
<xs:enumeration value="FriendlyExpression"/>
<!--Export Column-->
<xs:enumeration value="FileDataColumnID"/>
<xs:enumeration value="WriteBOM"/>
<xs:enumeration value="ForceTruncate"/>
<xs:enumeration value="AllowAppend"/>
<!--Fuzzy Grouping, Fuzzy Lookup-->
<xs:enumeration value="ToBeCleaned"/>
<xs:enumeration value="ExactFuzzy"/>
<xs:enumeration value="LeadingTrailingNumeralsSignificant"/>
<xs:enumeration value="MinSimilarity"/>
<xs:enumeration value="FuzzyComparisonFlags"/>
<!--Import Column-->
<xs:enumeration value="FileDataColumnID"/>
<xs:enumeration value="ExpectBOM"/>
<!--Lookup-->
<xs:enumeration value="JoinToReferenceColumn"/>
<xs:enumeration value="CopyFromReferenceColumn"/>
<!--Merge-->
<xs:enumeration value="OutputColumnLineageID"/>
<!--MergeJoin (none)-->
<!--Multicast (none)-->
<!--OLE DB Command (none)-->
<!--Percentage Sampling (none)-->
<!--Pivot-->
<xs:enumeration value="PivotUsage"/>
<!--RowCount (none)-->
<!--Row Sampling (none)-->
<!--Script Component (none)-->
<!--Slowly Changing Dimension-->
<xs:enumeration value="ColumnType"/>
<!--Sort-->
<xs:enumeration value="NewComparisonFlags"/>
<xs:enumeration value="NewSortKeyPosition"/>
<!--Term Extraction (none)-->
<!--Term Lookup-->
<xs:enumeration value="InputColumnType"/>
<!--UnionAll-->
<xs:enumeration value="OutputColumnLineageID"/>
<!--Unpivot-->
<xs:enumeration value="DestinationColumn"/>
<xs:enumeration value="PivotKeyValue"/>
<!--Data Destinations-->
<!--ADO.Net Destination (none)-->
<!--Excel Destination (none)-->
<!--Flat File Destination (none)-->
<!--OLE DB Destination (none)-->
<!--Raw File Destination (none)-->
<!--DataReader Destination (none)-->
<!--Data Mining Model Training (none)-->
<!--Dimension Processing (none)-->
<!--Partition Processing (none)-->
<!--RecordSet Destination (none)-->
<!--SQL Server Compact Destination (none)-->
<!--SQL Server Destination (none)-->
</xs:restriction>
</xs:simpleType>

```

2.7.1.1.1.3.1.3.1.1.1 **Aggregate Component inputColumn Element**

The Aggregate Component MUST NOT have any properties on the **inputColumn** element.

2.7.1.1.1.1.3.1.3.1.1.2 Audit Component inputColumn Element

The Audit Component MUST NOT have any properties on the **inputColumn** element.

2.7.1.1.1.1.3.1.3.1.1.3 Cache Transform Component inputColumn Element

The Cache Transform Component **inputColumn** element MUST NOT use any **Name** attribute value on a **property** element except for those that are listed in the table in this section.

The following table specifies the **Name** attribute values that are allowed for the Cache Transform Component Task on the **inputColumn** element, in addition to any restrictions on the element value. These restrictions MUST be followed.

| Name attribute value | Description |
|-----------------------------|---|
| CacheColumnName | A string value that specifies the name of a column that is associated with an input column. |

2.7.1.1.1.1.3.1.3.1.1.4 Character Map Component inputColumn Element

The Character Map Component **inputColumn** element MUST NOT use any **Name** attribute value on a **property** element except for those that are listed in the table in this section.

The following table specifies the **Name** attribute values that are allowed for the Character Map Component on the **inputColumn** element, in addition to any restrictions on the element value. These restrictions MUST be followed.

| Name attribute value | Description |
|-----------------------------|--|
| MapFlags | An integer value that specifies the string operation that is performed on the column. The allowed values are the following. 0 – Map to lower case. 1 – Map to upper case. 2 – Perform byte reversal. 3 – Map to Hiragana. 4 – Map to Katakana. 5 – Map to half width. 6 – Map to full width. 7 – Perform linguistic casing. 8 – Map to Simplified Chinese. 9 – Map to Traditional Chinese. |

2.7.1.1.1.1.3.1.3.1.1.5 Conditional Split Component inputColumn Element

The Conditional Split Component MUST NOT have any properties on the **inputColumn** element.

2.7.1.1.1.1.3.1.3.1.1.6 Copy Column Component inputColumn Element

The Copy Column Component MUST NOT have any properties on the **inputColumn** element.

2.7.1.1.1.1.3.1.3.1.1.7 Data Conversion Component inputColumn Element

The Data Conversion Component MUST NOT have any properties on the **inputColumn** element.

2.7.1.1.1.1.3.1.3.1.1.8 Data Mining Query Component inputColumn Element

The Data Mining Query Component **inputColumn** element MUST NOT have any properties on the **inputColumn** element.

2.7.1.1.1.1.3.1.3.1.1.9 Derived Column Component inputColumn Element

The Derived Column Component **inputColumn** element MUST NOT use any **Name** attribute value on a **property** element except for those that are listed in the table in this section.

The following table specifies the **Name** attribute values that are allowed for the Derived Column Component on the **inputColumn** element, in addition to any restrictions on the element value. These restrictions MUST be followed.

| Name attribute value | Description |
|-----------------------------|--|
| Expression | A string value that specifies the expression by which the column is derived. |
| FriendlyExpression | A string value that specifies a conditional expression by which the column is derived. The FriendlyExpression attribute uses column names in the expression syntax, while the Expression attribute uses only column lineage identifiers. |

2.7.1.1.1.1.3.1.3.1.1.10 Export Column Component inputColumn Element

The Export Column Component **inputColumn** element MUST NOT use any **Name** attribute value on a **property** element except for those that are listed in the table in this section.

The following table specifies the **Name** attribute values that are allowed for the Export Column Component on the **inputColumn** element, in addition to any restrictions on the element value. These restrictions MUST be followed.

| Name attribute value | Description |
|-----------------------------|--|
| FileDataColumnID | An integer value that specifies the identifier for the column that contains the data that is inserted by the task. |
| WriteBOM | A Boolean value that specifies whether a byte order mark (BOM) is inserted into the file. TRUE specifies that a BOM is inserted into the file. FALSE specifies that a BOM is not inserted into the file. |
| ForceTruncate | A Boolean value that specifies whether a truncation is forced before a write operation on an existing file. TRUE specifies that a truncation is forced before a write operation on an existing file. FALSE specifies that a truncation is not forced before a write operation on an existing file. |
| AllowAppend | A Boolean value that specifies whether the transformation is allowed to append data to an existing file. TRUE specifies that the transformation is allowed to append data to an existing file. FALSE specifies that the transformation is not allowed to append data to an existing file. |

2.7.1.1.1.1.3.1.3.1.1.11 Fuzzy Grouping Component inputColumn Element

The Fuzzy Grouping Component **inputColumn** element MUST NOT use any **Name** attribute value on a **property** element except for those that are listed in the table in this section.

The following table specifies the **Name** attribute values that are allowed for the Fuzzy Grouping Component on the **inputColumn** element, in addition to any restrictions on the element value. These restrictions MUST be followed.

| Name attribute value | Description |
|---|---|
| ToBeCleaned | A Boolean value that specifies whether this is a column to be grouped by. TRUE specifies that this is a column to be grouped by. FALSE specifies that this is not a column to be grouped by. |
| ExactFuzzy | An integer value that specifies whether the fuzzy match is exact or fuzzy. The allowed values are the following: 1 – Exact. 2 – Fuzzy. |
| LeadingTrailingNumeralsSignificant | An integer value that specifies how to treat numerals. The allowed values are as follows: 0 – Numerals are not significant. 1 – Leading numerals are significant. 2 – Trailing numerals are significant. 3 – Both leading and trailing numerals are significant. |
| MinSimilarity | A double precision value between 0 and 1, inclusive, that specifies the similarity threshold to join on the column. Only rows that are greater than this value qualify as matches. |
| FuzzyComparisonFlags | An integer value that is a bitmask that specifies the comparison flags for the sort operation. The bit values are as follows: 0x00000001 - Ignore case. 0x00000002 - Ignore nonspace characters. 0x00000004 - Ignore symbols. 0x00000100 - Sort punctuation as symbols. 0x00001000 - Ignore Kana type. 0x00002000 - Ignore character width. |

2.7.1.1.1.1.3.1.3.1.1.12 Fuzzy Lookup Component inputColumn Element

The Fuzzy Lookup Component **inputColumn** element MUST NOT use any **Name** attribute value on a **property** element except for those that are listed in the table in this section.

The following table specifies the **Name** attribute values that are allowed for the Fuzzy Lookup Component on the **inputColumn** element, in addition to any restrictions on the element value. These restrictions MUST be followed.

| Name attribute value | Description |
|---|--|
| ToBeCleaned | A Boolean value that specifies whether this is a column to be grouped by. TRUE specifies that this is a column to be grouped by. FALSE specifies that this is not a column to be grouped by. |
| ExactFuzzy | An integer value that specifies whether the fuzzy match is exact or fuzzy. The allowed values are the following: 1 – Exact 2 – Fuzzy |
| LeadingTrailingNumeralsSignificant | An integer value that specifies how to treat numerals. The allowed values are as follows: 0 – Numerals are not significant. 1 – Leading numerals are significant. |

| Name attribute value | Description |
|-----------------------------|---|
| | 2- Trailing numerals are significant. 3 - Both leading and trailing numerals are significant. |
| MinSimilarity | A double precision value between 0 and 1, inclusive, that specifies the similarity threshold to join on the column. Only rows that are greater than this value qualify as matches. |
| FuzzyComparisonFlags | An integer value that is a bitmask that specifies the comparison flags for the sort operation. The bit values are as follows: 0x00000001 - Ignore case. 0x00000002 - Ignore nonspace characters. 0x00000004 - Ignore symbols. 0x00000100 - Sort punctuation as symbols. 0x00001000 - Ignore Kana type. 0x00002000 - Ignore character width. |

2.7.1.1.1.1.3.1.3.1.1.13 Import Column Component inputColumn Element

The Import Column Component **inputColumn** element MUST NOT use any **Name** attribute value on a **property** element except for those that are listed in the table in this section.

The following table specifies the **Name** attribute values that are allowed for the Import Column Component on the **inputColumn** element, in addition to any restrictions on the element value. These restrictions MUST be followed.

| Name attribute value | Description |
|-------------------------|--|
| FileDataColumnID | An integer value that specifies the identifier for the column that contains the data that is inserted into the data flow. |
| ExpectBOM | A Boolean value that specifies whether a byte order mark (BOM) is expected in the column. TRUE specifies that a BOM is expected in the column. FALSE specifies that a BOM is not expected in the column. |

2.7.1.1.1.1.3.1.3.1.1.14 Lookup Component inputColumn Element

The Lookup Component **inputColumn** element MUST NOT use any **Name** attribute value on a **property** element except for those that are listed in the table in this section.

The following table specifies the **Name** attribute values that are allowed for the Lookup Component on the **inputColumn** element, in addition to any restrictions on the element value. These restrictions MUST be followed.

| Name attribute value | Description |
|--------------------------------|--|
| JoinToReferenceColumn | A string value that specifies the name of the column in the reference table upon which to join. |
| CopyFromReferenceColumn | A string value that specifies the name of the column in the reference table from which a column is copied. |

2.7.1.1.1.1.3.1.3.1.1.15 Merge Component inputColumn Element

The Merge Component MUST NOT have any properties on the **inputColumn** element.

2.7.1.1.1.1.3.1.3.1.1.16 MergeJoin Component inputColumn Element

The MergeJoin Component MUST NOT have any properties on the **inputColumn** element.

2.7.1.1.1.1.3.1.3.1.1.17 Multicast Component inputColumn Element

The Multicast Component MUST NOT have any properties on the **inputColumn** element.

2.7.1.1.1.1.3.1.3.1.1.18 OLE DB Command Component inputColumn Element

The OLE DB Command Component MUST NOT have any properties on the **inputColumn** element.

2.7.1.1.1.1.3.1.3.1.1.19 Percentage Sampling Component inputColumn Element

The Percentage Sampling Component MUST NOT have any properties on the **inputColumn** element.

2.7.1.1.1.1.3.1.3.1.1.20 Pivot Component inputColumn Element

The Pivot Component **inputColumn** element MUST NOT use any **Name** attribute value on a **property** element except for those that are listed in the table in this section.

The following table specifies the **Name** attribute values that are allowed for the Pivot Component Task on the **inputColumn** element, in addition to any restrictions on the element value. These restrictions MUST be followed.

| Name attribute value | Description |
|-----------------------------|---|
| PivotUsage | An integer value that specifies the role of a column for pivoting. The allowed values are the following. 0 – The column is not pivoted. 1 – The column provides row keys. All input rows with the same value are combined into one output row. 2 – The column is a pivot column. At least one column is created for each value in this column. 3 – The values from this column are placed in one of the cells created by the pivot. |

2.7.1.1.1.1.3.1.3.1.1.21 RowCount Component inputColumn Element

The RowCount Component MUST NOT have any properties on the **inputColumn** element.

2.7.1.1.1.1.3.1.3.1.1.22 Row Sampling Component inputColumn Element

The Row Sampling Component MUST NOT have any properties on the **inputColumn** element.

2.7.1.1.1.1.3.1.3.1.1.23 Script Component inputColumn Element

The Script Component MUST NOT have any properties on the **inputColumn** element.

2.7.1.1.1.1.3.1.3.1.1.24 Slowly Changing Dimension Component inputColumn Element

The Slowly Changing Dimension Component **inputColumn** element MUST NOT use any **Name** attribute value on a **property** element except for those that are listed in the table in this section.

The following table specifies the **Name** attribute values that are allowed for the Slowly Changing Dimension Component Task on the **inputColumn** element, in addition to any restrictions on the element value. These restrictions MUST be followed.

| Name attribute value | Description |
|----------------------|--|
| ColumnType | An integer value that specifies the update type for the column. 0 – Unknown. 1 – Key column. 2 – Changing attribute. 3 – Historical attribute. 4 – Fixed attribute. |

2.7.1.1.1.1.3.1.3.1.1.25 Sort Component inputColumn Element

The Sort Component **inputColumn** element MUST NOT use any **Name** attribute value on a **property** element except for those that are listed in the table in this section.

The following table specifies the **Name** attribute values that are allowed for the Sort Component on the **inputColumn** element in addition to any restrictions on the element value. These restrictions MUST be followed.

| Name attribute value | Description |
|---------------------------|---|
| NewComparisonFlags | An integer value that is a bitmask that specifies the comparison flags for the sort operation. The bit values are as follows: 0x00000001 - Ignore case. 0x00000002 - Ignore nonspace characters. 0x00000004 - Ignore symbols. 0x00000100 - Sort punctuation as symbols. 0x00001000 - Ignore Kana type. 0x00002000 - Ignore character width. |
| NewSortKeyPosition | An integer value that specifies the sort order of the column. |

2.7.1.1.1.1.3.1.3.1.1.26 Term Extraction Component inputColumn Element

The Term Extraction Component MUST NOT have any properties on the **inputColumn** element.

2.7.1.1.1.1.3.1.3.1.1.27 Term Lookup Component inputColumn Element

The Term Lookup Component **inputColumn** element MUST NOT use any **Name** attribute value on a **property** element except for those that are listed in the table in this section.

The following table specifies the **Name** attribute values that are allowed for the Term Lookup Component Task on the **inputColumn** element, in addition to any restrictions on the element value. These restrictions MUST be followed.

| Name attribute value | Description |
|------------------------|---|
| InputColumnType | An integer value that specifies the input column type. The allowed values are the following: 0 – Passthrough column. 1 – Lookup column. 2 – Passthrough and lookup column. |

2.7.1.1.1.1.3.1.3.1.1.28 Union All Component inputColumn Element

The Union All Component **inputColumn** element MUST NOT use any **Name** attribute value on a **property** element except for those that are listed in the table in this section.

The following table specifies the **Name** attribute values that are allowed for the Union All Component on the **inputColumn** element, in addition to any restrictions on the element value. These restrictions MUST be followed.

| Name attribute value | Description |
|------------------------------|--|
| OutputColumnLineageID | An integer value that specifies the lineage identifier of the corresponding output column. |

2.7.1.1.1.1.3.1.3.1.1.29 Unpivot Component inputColumn Element

The Unpivot Component **inputColumn** element MUST NOT use any **Name** attribute value on a **property** element except for those that are listed in the table in this section.

The following table specifies the **Name** attribute values that are allowed for the Unpivot Component on the **inputColumn** element, in addition to any restrictions on the element value. These restrictions MUST be followed.

| Name attribute value | Description |
|--------------------------|---|
| DestinationColumn | An integer value that specifies the lineage identifier of the corresponding output column. <51> |
| PivotKeyValue | A string value that specifies one of the pivot key values that is copied to an output column. |

2.7.1.1.1.1.3.1.3.1.1.30 ADO.NET Destination Component inputColumn Element

The ADO.NET Destination Component MUST NOT have any properties on the **inputColumn** element.

2.7.1.1.1.1.3.1.3.1.1.31 Excel Destination Component inputColumn Element

The Excel Destination Component MUST NOT have any properties on the **inputColumn** element.

2.7.1.1.1.1.3.1.3.1.1.32 Flat File Destination Component inputColumn Element

The Flat File Destination Component MUST NOT have any properties on the **inputColumn** element.

2.7.1.1.1.1.3.1.3.1.1.33 OLE DB Destination Component inputColumn Element

The OLE DB Destination Component MUST NOT have any properties on the **inputColumn** element.

2.7.1.1.1.1.3.1.3.1.1.34 DataReader Destination Component inputColumn Element

The DataReader Destination Component MUST NOT have any properties on the **inputColumn** element.

2.7.1.1.1.1.3.1.3.1.1.35 Data Mining Model Training Destination Component inputColumn Element

The Data Mining Model Training Destination Component MUST NOT have any properties on the **inputColumn** element.

2.7.1.1.1.1.3.1.3.1.1.36 Dimension Processing Destination Component inputColumn Element

The Dimension Processing Destination Component MUST NOT have any properties on the **inputColumn** element.

2.7.1.1.1.1.3.1.3.1.1.37 Partition Processing Destination Component inputColumn Element

The Partition Processing Destination Component MUST NOT have any properties on the **inputColumn** element.

2.7.1.1.1.1.3.1.3.1.1.38 Raw File Destination Component inputColumn Element

The Raw File Destination Component MUST NOT have any properties on the **inputColumn** element.

2.7.1.1.1.1.3.1.3.1.1.39 RecordSet Destination Component inputColumn Element

The RecordSet Destination Component MUST NOT have any properties on the **inputColumn** element.

2.7.1.1.1.1.3.1.3.1.1.40 SQL Server Compact Edition Destination Component inputColumn Element

The SQL Server Compact Edition Destination Component MUST NOT have any properties on the **inputColumn** element.

2.7.1.1.1.1.3.1.3.1.1.41 SQL Server Destination Component inputColumn Element

The SQL Server Destination Component MUST NOT have any properties on the **inputColumn** element.

2.7.1.1.1.1.3.1.3.2 PipelineComponentUsageTypeEnum

The **PipelineComponentUsageTypeEnum** type contains the enumeration values for the **usageType** attribute.

The following is the XSD for the **PipelineComponentUsageTypeEnum** type.

```
<xs:simpleType name="PipelineComponentUsageTypeEnum">
  <xs:restriction base="xs:string">
    <xs:enumeration value="readOnly"/>
    <xs:enumeration value="readWrite"/>
    <xs:enumeration value="Ignored"/>
  </xs:restriction>
</xs:simpleType>
```

The following table specifies the enumeration values for the **PipelineComponentUsageTypeEnum** type.

| Enumeration value | Description |
|-------------------|---|
| readOnly | The column is read-only. |
| readWrite | The column is available for read operations and for write operations. |
| Ignored | The column is ignored. |

2.7.1.1.1.1.3.1.4 PipelineComponentInputPropertiesType

The **PipelineComponentInputPropertiesType** type specifies a collection of properties for an **input** element that is part of a Pipeline component.

The following is the XSD for the **PipelineComponentInputPropertiesType** type.

```
<xs:complexType name="PipelineComponentInputPropertiesType">
  <xs:sequence>
    <xs:element name="property" form="unqualified"
      type="DTS:PipelineComponentInputPropertyType"
      minOccurs="0" maxOccurs="unbounded"/>
  </xs:sequence>
</xs:complexType>
```

The following table specifies the elements of the **PipelineComponentInputPropertiesType** type.

| Element | Type definition | Description |
|-----------------|--|--|
| property | PipelineComponentInputPropertyType | A complex type that specifies a single property within a collection of input properties for an input element of a Pipeline component. |

2.7.1.1.1.3.1.5 PipelineComponentInputPropertyType

The **PipelineComponentInputPropertyType** type specifies the structure in which the value for a single property of an input of a component is held. All inputs do not use the same set of properties, so this general structure is designed to hold the variety of properties that an input can have.

The following is the XSD for the **PipelineComponentInputPropertyType** type.

```
<xs:complexType name="PipelineComponentInputPropertyType"
  mixed="true">
  <xs:sequence>
    <xs:element name="arrayElements"
      type="DTS:PipelineComponentArrayElementsType"
      form="unqualified" minOccurs="0"/>
  </xs:sequence>
  <xs:attributeGroup
    ref="DTS:PipelineComponentPropertyAttributeGroup"/>
  <xs:attribute name="name"
    type="DTS:PipelineComponentInputPropertyNameEnum"
    form="unqualified"/>
</xs:complexType>
```

The following table specifies the elements of the **PipelineComponentInputPropertyType** type.

| Element | Type definition | Description |
|----------------------|--|---|
| arrayElements | PipelineComponentArrayElementsType | A complex type that contains a collection of elements that form an array. The collection constitutes the value for the property. This element is used only if the isArray attribute value is TRUE. |

The following table specifies the attribute groups and the attributes of the **PipelineComponentInputPropertyType** type.

| Attribute | Description |
|--|---|
| PipelineComponentPropertyAttributeGroup | An attribute group that contains attributes that are common to all property elements for input elements, output elements, inputColumn elements, and outputColumn elements. |

| Attribute | Description |
|-------------|---|
| name | A string value that specifies the name of the property. |

2.7.1.1.1.3.1.6 PipelineComponentInputPropertyNameEnum

The **PipelineComponentInputPropertyNameEnum** type contains the allowed values for the **name** attribute on the **input** element of a Pipeline Task. The allowed values for the **property** element for each task are more restricted than the values that are specified formally by the XSD.

No tasks allow any property elements on the **input** element. Therefore, the **PipelineComponentInputPropertyNameEnum** type does not contain any enumerated values. It is specified as a type as the **property** element itself is valid, and custom components can add valid property names for the name attribute. For more information about the addition of properties by custom programmers, see [Custom Packages](#).

All tasks MUST NOT have any properties on the **input** element.

The following is the XSD for the **PipelineComponentInputPropertyNameEnum** type.

```
<xs:simpleType name="PipelineComponentInputPropertyNameEnum">
  <xs:restriction base="xs:string">
    </xs:restriction>
  <!--None of the components have properties for the Input element-->
</xs:simpleType>
```

2.7.1.1.1.4 PipelineComponentOutputsType

The **PipelineComponentOutputsType** type specifies a collection of output objects for a component.

The following is the XSD for the **PipelineComponentOutputsType** type.

```
<xs:complexType name="PipelineComponentOutputsType">
  <xs:sequence>
    <xs:element name="output" form="unqualified"
      type="DTS:PipelineComponentOutputType"
      minOccurs="0" maxOccurs="unbounded"/>
  </xs:sequence>
</xs:complexType>
```

The following table specifies the elements of the **PipelineComponentOutputsType** type.

| Element | Type definition | Description |
|---------------|---|---|
| output | PipelineComponentOutputType | A complex type that specifies a reference to an output that is created by this component and that is available to other components. |

2.7.1.1.1.4.1 PipelineComponentOutputType

The **PipelineComponentOutputType** type specifies the structure in which the descriptor for a single output from a component is held. All outputs are not identical, so this general structure is designed to hold the variety of outputs that a component can have.

The following is the XSD for the **PipelineComponentOutputType** type.

```
<xs:complexType name="PipelineComponentOutputType">
  <xs:sequence>
    <xs:element name="properties"
      type="DTS:PipelineComponentOutputPropertiesType"
      minOccurs="0" form="unqualified"/>
    <xs:element name="outputColumns"
      type="DTS:PipelineComponentOutputColumnsType"
      minOccurs="0" form="unqualified"/>
    <xs:element name="externalMetadataColumns"
      type="DTS:PipelineComponentMetadataColumnsType"
      minOccurs="0" form="unqualified"/>
  </xs:sequence>
  <xs:attributeGroup
    ref="DTS:PipelineComponentInputOutputElementAttributeGroup"/>
  <xs:attribute name="exclusionGroup" type="xs:int"
    form="unqualified"/>
  <xs:attribute name="synchronousInputId" type="xs:string"
    form="unqualified"/>
  <xs:attribute name="deleteOutputOnPathDetached" type="xs:boolean"
    form="unqualified"/>
  <xs:attribute name="isErrorOut" type="xs:boolean"
    form="unqualified"/>
  <xs:attribute name="isSorted" type="xs:boolean" form="unqualified"/>
</xs:complexType>
```

The following table specifies the elements of the **PipelineComponentOutputType** type.

| Element | Type definition | Description |
|--------------------------------|--|---|
| properties | PipelineComponentPropertiesType | A complex type that specifies a collection of properties that are associated with the output element. |
| outputColumns | PipelineComponentOutputColumnsType | A complex type that specifies a collection of output columns that are associated with the output element. |
| externalMetadataColumns | PipelineComponentMetadataColumnsType | A complex type that specifies a collection of external metadata columns that are associated with the output element. |

The following table specifies the attribute groups and the attributes of the **PipelineComponentOutputType** type.

| Attribute | Description |
|--|---|
| PipelineComponentInputOutputElementAttributeGroup | An attribute group specification that specifies attributes that are common for the input element and for the output element of the PipelineComponentOutputType type. |
| exclusionGroup | An integer value that specifies a hint to the data flow engine about whether copies of flowing data need to be made for multiple outputs. If multiple outputs share the same exclusionGroup value, the engine guarantees that input rows will only be output to one of those outputs. If the exclusionGroup value is "0", or the exclusionGroup attribute for outputs is unequal, no such guarantee is made. |

| Attribute | Description |
|-----------------------------------|---|
| synchronousInputId | An integer value that specifies the id attribute of an input that is synchronous with this output. |
| deleteOutputOnPathDetached | A Boolean value that determines whether the data flow engine deletes the output when it is detached from a path. TRUE specifies that the output is deleted when it is detached from a path. FALSE specifies that the output is not deleted when it is detached from a path. |
| isErrorOut | A Boolean value that specifies whether the output is an error output. TRUE specifies that the output is an error output. FALSE specifies that the output is not an error output. |
| isSorted | A Boolean value that specifies whether the output is sorted. TRUE specifies that the output is sorted. FALSE specifies that the output is not sorted. |

2.7.1.1.1.4.1.1 PipelineComponentOutputColumnsType

The **PipelineComponentOutputColumnsType** type specifies a collection of column objects for an **output** element that is part of a Pipeline component.

The following is the XSD for the **PipelineComponentOutputColumnsType** type.

```
<xs:complexType name="PipelineComponentOutputColumnsType">
  <xs:sequence>
    <xs:element name="outputColumn"
      type="DTS:PipelineComponentOutputColumnType"
      minOccurs="0" maxOccurs="unbounded" form="unqualified"/>
  </xs:sequence>
</xs:complexType>
```

The following table specifies the elements of the **PipelineComponentOutputColumnsType** type.

| Element | Type definition | Description |
|---------------------|-----------------------------------|---|
| outputColumn | PipelineComponentOutputColumnType | A complex type that specifies a single column within a collection of output columns for a Pipeline component. |

2.7.1.1.1.4.1.1.1 PipelineComponentOutputColumnType

The **PipelineComponentOutputColumnType** type specifies a single column that is a member of a collection of output columns in a Pipeline component.

The following is the XSD for the **PipelineComponentOutputColumnType** type.

```
<xs:complexType name="PipelineComponentOutputColumnType">
  <xs:sequence>
    <xs:element name="properties"
      type="DTS:PipelineComponentOutputColumnPropertiesType"
      minOccurs="0" maxOccurs="1" form="unqualified"/>
  </xs:sequence>
</xs:complexType>
```

```

        form="unqualified" minOccurs="0" maxOccurs="unbounded"/>
</xs:sequence>
<xs:attributeGroup
  ref="DTS:PipelineComponentAllColumnBaseAttributeGroup"/>
<xs:attributeGroup
  ref="DTS:PipelineComponentIOColumnBaseAttributeGroup"/>
<xs:attributeGroup
  ref="DTS:PipelineComponentColumnExtendedAttributeGroup"/>
<xs:attribute name="sortKeyPosition" type="xs:int"
  form="unqualified"/>
<xs:attribute name="comparisonFlags" type="xs:int"
  form="unqualified"/>
<xs:attribute name="specialFlags" form="unqualified">
  <xs:simpleType>
    <xs:restriction base="xs:int">
      <xs:minInclusive value="0"/>
      <xs:maxInclusive value="2"/>
    </xs:restriction>
  </xs:simpleType>
</xs:attribute>
</xs:complexType>

```

The following table specifies the elements of the **PipelineComponentOutputColumnType** type.

| Element | Type definition | Description |
|-------------------|---------------------------------|--|
| properties | PipelineComponentPropertiesType | A complex type that specifies a collection of properties for an output column. |

The following table specifies the attributes and attribute groups of the **PipelineComponentOutputColumnType** type.

| Attribute group or attribute | Description |
|--|--|
| PipelineComponentAllColumnBaseAttributeGroup | An attribute group specification that specifies attributes that are common to all types of columns for Pipeline components. |
| PipelineComponentIOColumnBaseAttributeGroup | An attribute group specification that specifies attributes that are common to all input and output columns for Pipeline components. |
| PipelineComponentColumnExtendedAttributeGroup | An attribute group specification that specifies additional attributes present for the PipelineComponentOutputColumnType type. |
| sortKeyPosition | An integer value that specifies the position of this column among the sort keys. |
| comparisonFlags | An integer value that is a bitmask that specifies which options are chosen for comparison of values in the column. The interpretation of the bits in this integer is as follows: 0x00000001 – Ignore case. 0x00000002 – Ignore nonspace characters. 0x00000004 – Ignore symbols. 0x00000010 – Linguistically appropriate ignore case. 0x00000020 – Linguistically appropriate ignore nonspace characters. 0x00010000 – Ignore Kana type. 0x00020000 – Ignore width. |

| Attribute group or attribute | Description |
|------------------------------|--|
| | 0x08000000 – Use linguistic rules for casing. |
| specialFlags | An integer enumeration value that specifies whether the column contains special information. The allowed values are the following: 0 – No special information is contained in the column. 1 – The data in the column contains error codes. 2 – The data in the column contains the lineage identifier of the column in which an error occurred. |

2.7.1.1.1.4.1.1.2 **PipelineComponentOutputColumnPropertiesType**

The **PipelineComponentOutputColumnPropertiesType** type specifies a collection of properties for an **outputColumn** element that is part of a Pipeline component.

The following is the XSD for the **PipelineComponentOutputColumnPropertiesType** type.

```
<xs:complexType name="PipelineComponentOutputColumnPropertiesType">
  <xs:sequence>
    <xs:element name="property" form="unqualified"
      type="DTS:PipelineComponentOutputColumnPropertyType"
      minOccurs="0" maxOccurs="unbounded"/>
  </xs:sequence>
</xs:complexType>
```

The following table specifies the elements of the **PipelineComponentOutputColumnPropertiesType** type.

| Element | Type definition | Description |
|-----------------|---|--|
| property | PipelineComponentOutputColumnPropertyType | A complex type that specifies a single property within a collection of input column properties for an outputColumn element of a Pipeline component. |

2.7.1.1.1.4.1.1.2.1 **PipelineComponentOutputColumnPropertyType**

The **PipelineComponentOutputColumnPropertyType** type specifies a property for an **outputColumn** element.

The following is the XSD for the **PipelineComponentOutputColumnPropertyType** type.

```
<xs:complexType name="PipelineComponentOutputColumnPropertyType">
  <xs:simpleContent>
    <xs:extension base="xs:anySimpleType">
      <xs:attributeGroup
        ref="DTS:PipelineComponentPropertyAttributeGroup"/>
      <xs:attribute name="name" form="unqualified"
        type="DTS:PipelineComponentOutputColumnPropertyNameEnum"/>
    </xs:extension>
  </xs:simpleContent>
</xs:complexType>
```

The following table specifies the attributes and attribute groups of the **PipelineComponentOutputColumnPropertyType** type.

| Attribute group | Description |
|--|---|
| PipelineComponentPropertyAttributeGroup | An attribute group that contains attributes that are common to all property elements for input elements, output elements, inputColumn elements, and outputColumn elements. |
| name | An enumeration value that specifies the name of the property. |

2.7.1.1.1.1.4.1.1.2.1.1 **PipelineComponentOutputColumnPropertyNameEnum**

The **PipelineComponentOutputColumnPropertyNameEnum** type contains the allowed values for the **name** attribute on the **outputColumn** element of a Pipeline component. The allowed values for the **property** element for each task are more restricted than the values that are specified formally by the XSD.

Each **name** attribute value MUST NOT be used for any component except for the components that are specified in the subsections to this section. Some components allow no properties.

The additional restrictions specified in the subsections to this section MUST be followed for the **name** attribute on the **property** element children of the **outputColumn** element.

```
<xs:simpleType name="PipelineComponentOutputColumnPropertyNameEnum">
  <xs:restriction base="xs:string">
    <!--Transforms-->
    <!--Aggregate Task-->
    <xs:enumeration value="AggregationColumnId"/>
    <xs:enumeration value="AggregationType"/>
    <xs:enumeration value="IsBig"/>
    <xs:enumeration value="AggregationComparisonFlags"/>
    <xs:enumeration value="CountDistinctKey"/>
    <xs:enumeration value="CountDistinctScale"/>
    <!--Audit-->
    <xs:enumeration value="LineageItemSelected"/>
    <!--Cache Transform (none)-->
    <!--Character Map (none)-->
    <!--Conditional Split (none)-->
    <!--Copy Column (none)-->
    <xs:enumeration value="copyColumnId"/>
    <!--Data Conversion (none)-->
    <xs:enumeration value="SourceInputColumnLineageID"/>
    <xs:enumeration value="FastParse"/>
    <!--Data Mining Query-->
    <!--Derived Column Query (none)-->
    <xs:enumeration value="Expression"/>
    <xs:enumeration value="FriendlyExpression"/>
    <!--Export Column Query (none)-->
    <!--Fuzzy Grouping-->
    <xs:enumeration value="ColumnType"/>
    <xs:enumeration value="InputId"/>
    <!--Fuzzy Lookup-->
    <xs:enumeration value="CopyFromReferenceColumn"/>
    <xs:enumeration value="SourceInputColumnLineageID"/>
    <xs:enumeration value="ColumnType"/>
    <!--Import Column (none)-->
    <!--Lookup-->
    <xs:enumeration value="CopyFromReferenceColumn"/>
    <!--Merge (none)-->
    <!--MergeJoin-->
    <xs:enumeration value="InputColumnID"/>
    <!--Multicast (none)-->
    <!--OLE DB Command (none)-->
    <!--Percentage Sampling (none)-->
    <!--Pivot-->
```

```

<xs:enumeration value="SourceColumn"/>
<xs:enumeration value="PivotKeyValue"/>
<!--RowCount (none)-->
<!--Row Sampling-->
<xs:enumeration value="InputColumnLineageID"/>
<!--Script Component (none)-->
<!--Slowly Changing Dimension (none)-->
<!--Sort-->
<xs:enumeration value="SortColumnId"/>
<!--Term Extraction(none)-->
<!--Term Lookup-->
<xs:enumeration value="CustomLineageID"/>
<!--UnionAll (none)-->
<!--Unpivot (none)-->
<xs:enumeration value="PivotKey"/>
<!--Data Sources-->
<!--ADO.Net Source(none)-->
<!--Excel Source(none)-->
<!--Flat File Source-->
<xs:enumeration value="FastParse"/>
<xs:enumeration value="UseBinaryFormat"/>
<!--OLEDB Source Task(none)-->
<!--Raw File Source(none)-->
<!--XML Source(none)-->
</xs:restriction>
</xs:simpleType>

```

2.7.1.1.1.4.1.1.2.1.1.1 **Aggregate Component outputColumn Element**

The Aggregate Component **outputColumn** element MUST NOT use any **Name** attribute value on a **property** element except for those that are listed in the table in this section.

The following table specifies the name attribute values that are allowed for the Aggregate Component Task on the **outputColumn** element, in addition to any restrictions on the element value. These restrictions MUST be followed.

| Name attribute value | Description |
|-----------------------------------|--|
| AggregationColumnId | An integer value that specifies the lineage identifier of a column that participates in a GroupBy or an aggregation operation. |
| AggregationType | An integer value that specifies the type of aggregation to be performed. The enumeration values are interpreted as follows: 0 - Group by. 1 - Count. 2 - Count all. 3 - Count distinct. 4 - Sum. 5 - Average. 6 - Minimum. 7 - Maximum. |
| IsBig | A Boolean value that specifies whether the column has a very large value (greater than 4 billion) or a very precise value (more precision than double precision). TRUE specifies that the column contains a very large or very precise value. FALSE specifies that the column does not contain a very large or very precise value. |
| AggregationComparisonFlags | An integer value that is a bitmask that specifies the comparison flags for the sort operation. The bit values are as follows: |

| Name attribute value | Description |
|---------------------------|---|
| | 0x00000001 - Ignore case. 0x00000002 - Ignore nonspace characters. 0x00001000 - Ignore Kana type. 0x00002000 - Ignore character width. |
| CountDistinctScale | An integer value that specifies the approximate number of groups that is expected by the operation. This value is used to optimize computation. The enumeration values are interpreted as follows: 0 - The key scale is not used. 1 - Aggregation writes 0 to 500,000 keys. 2 - Aggregation writes 500,000 to 25,000,000 keys. 3- Aggregation writes more than 25,000,000 keys. |
| CountDistinctKeys | An integer value that specifies the exact number of GroupBy keys that can be written. If this value is specified, it takes precedence over the value of the CountDistinctScale attribute. |

2.7.1.1.1.1.4.1.1.2.1.1.2 Audit Component outputColumn Element

The Audit Component **outputColumn** element MUST NOT use any **Name** attribute value on a **property** element except for those that are listed in the table in this section.

The following table specifies the **Name** attribute values that are allowed for Audit Component on the **outputColumn** element, in addition to any restrictions on the element value. These restrictions MUST be followed.

| Name attribute value | Description |
|----------------------------|---|
| LineageItemSelected | An integer value that specifies the audit item that is selected for output. The allowed values are as follows: 0 - Execution Instance GUID. 1 - Package ID. 2 - Package Name. 3 - Version ID. 4 - Execution Start Time. 5 - Machine Name. 6 - User Name. 7 - Task Name. 8 - Task ID. |

2.7.1.1.1.1.4.1.1.2.1.1.3 Cache Transform Component outputColumn Element

The Cache Transform Component MUST NOT have any properties on the **outputColumn** element.

2.7.1.1.1.1.4.1.1.2.1.1.4 Character Map Component outputColumn Element

The Character Map Component MUST NOT have any properties on the **outputColumn** element.

2.7.1.1.1.1.4.1.1.2.1.1.5 Conditional Split Component outputColumn Element

The Conditional Split Component MUST NOT have any properties on the **outputColumn** element.

2.7.1.1.1.1.4.1.1.2.1.1.6 Copy Column Component outputColumn Element

The Copy Column Component **outputColumn** element MUST NOT use any **Name** attribute value on a **property** element except for those that are listed in the table in this section.

The following table specifies the **Name** attribute values that are allowed for Copy Column Component on the **outputColumn** element, in addition to any restrictions on the element value. These restrictions MUST be followed.

| Name attribute value | Description |
|----------------------|---|
| copyColumnId | An integer value that specifies the lineage identifier of the column to copy. |

2.7.1.1.1.1.4.1.1.2.1.1.7 Data Conversion Component outputColumn Element

The Data Conversion Component **outputColumn** element MUST NOT use any **Name** attribute value on a **property** element except for those that are listed in the table in this section.

The following table specifies the **Name** attribute values that are allowed for Data Conversion Component on the **outputColumn** element, in addition to any restrictions on the element value. These restrictions MUST be followed.

| Name attribute value | Description |
|-----------------------------------|---|
| SourceInputColumnLineageId | An integer value that specifies the lineage identifier of the source input column. |
| FastParse | A Boolean value that specifies whether to use the locale-neutral fast parse algorithm. TRUE specifies to use the fast parse algorithm. FALSE specifies not to use the fast parse algorithm. |

2.7.1.1.1.1.4.1.1.2.1.1.8 Data Mining Query Component outputColumn Element

The Data Mining Query Component MUST NOT have any properties on the **outputColumn** element.

2.7.1.1.1.1.4.1.1.2.1.1.9 Derived Column Component outputColumn Element

The Derived Column Component **outputColumn** element MUST NOT use any **Name** attribute value on a **property** element except for those that are listed in the table in this section.

The following table specifies the **Name** attribute values that are allowed for Derived Column Component on the **outputColumn** element, in addition to any restrictions on the element value. These restrictions MUST be followed.

| Name attribute value | Description |
|---------------------------|---|
| Expression | A string value that specifies the expression by which the column is derived. |
| FriendlyExpression | A Boolean value that specifies whether to use the locale-neutral fast parse algorithm. TRUE specifies to use the fast parse algorithm. FALSE specifies not to use the fast parse algorithm. |

2.7.1.1.1.1.4.1.1.2.1.1.10 Export Column Component outputColumn Element

The Export Column Component MUST NOT have any properties on the **outputColumn** element.

2.7.1.1.1.1.4.1.1.2.1.1.11 Fuzzy Grouping Component outputColumn Element

The Fuzzy Grouping Component **outputColumn** element MUST NOT use any **Name** attribute value on a **property** element except for those that are listed in the table in this section.

The following table specifies the **Name** attribute values that are allowed for Fuzzy Grouping Component on the **outputColumn** element, in addition to any restrictions on the element value. These restrictions MUST be followed.

| Name attribute value | Description |
|----------------------|--|
| ColumnType | An integer value that specifies the type of the column. The allowed values are as follows: 0 – The type of the column is undefined. 1 – The column is a key input. 2 – The column is a key output. 3 – The column contains the similarity value. 4 – The column contains the column similarity value. 5 – The column is passthrough. 6 – The column is canonical. |
| InputId | An integer value that specifies the lineage identifier of the corresponding input column. |

2.7.1.1.1.1.4.1.1.2.1.1.12 Fuzzy Lookup Component outputColumn Element

The Fuzzy Lookup Component **outputColumn** element MUST NOT use any **Name** attribute value on a **property** element except for those that are listed in the table in this section.

The following table specifies the **Name** attribute values that are allowed for Fuzzy Lookup Component on the **outputColumn** element, in addition to any restrictions on the element value. These restrictions MUST be followed.

| Name attribute value | Description |
|-----------------------------------|--|
| CopyFromReferenceColumn | A string value that specifies the name of the column in the reference table that provides the values for this output column. |
| SourceInputColumnLineageID | An integer value that specifies the lineage identifier of the source input column. |
| ColumnType | An integer value that specifies the type of the column. The allowed values are as follows: 0 – The type of the column is undefined. 1 – The column contains the similarity value. 2 – The column contains the confidence value. 3 – The column contains the column similarity value. |
| InputId | An integer value that specifies the lineage identifier of the corresponding input column. |

2.7.1.1.1.1.4.1.1.2.1.1.13 Import Column Component outputColumn Element

The Import Column Component MUST NOT have any properties on the **outputColumn** element.

2.7.1.1.1.1.4.1.1.2.1.1.14 Lookup Component outputColumn Element

The Lookup Component **outputColumn** element MUST NOT use any **Name** attribute value on a **property** element except for those that are listed in the table in this section.

The following table specifies the **Name** attribute values that are allowed for Lookup Component on the **outputColumn** element, in addition to any restrictions on the element value. These restrictions MUST be followed.

| Name attribute value | Description |
|--------------------------------|--|
| CopyFromReferenceColumn | A string value that specifies the name of the column in the reference table that provides the values for this output column. |

2.7.1.1.1.1.4.1.1.2.1.1.15 Merge Component outputColumn Element

The Merge Component **outputColumn** element MUST NOT use any **Name** attribute value on a **property** element except for those that are listed in the table in this section.

The following table specifies the **Name** attribute values that are allowed for Merge Component on the **outputColumn** element, in addition to any restrictions on the element value. These restrictions MUST be followed.

| Name attribute value | Description |
|------------------------------|--|
| OutputColumnLineageID | A string value that specifies the lineage identifier of the output column. |

2.7.1.1.1.1.4.1.1.2.1.1.16 MergeJoin Component outputColumn Element

The MergeJoin Component **outputColumn** element MUST NOT use any **Name** attribute value on a **property** element except for those that are listed in the table in this section.

The following table specifies the **Name** attribute values that are allowed for MergeJoin Component on the **outputColumn** element, in addition to any restrictions on the element value. These restrictions MUST be followed.

| Name attribute value | Description |
|----------------------|---|
| InputColumnID | A string value that specifies the lineage identifier of the input column from which data is copied to this output column. |

2.7.1.1.1.1.4.1.1.2.1.1.17 Multicast Component outputColumn Element

The Multicast Component MUST NOT have any properties on the **outputColumn** element.

2.7.1.1.1.1.4.1.1.2.1.1.18 OLE DB Command Component outputColumn Element

The OLE DB Command Component MUST NOT have any properties on the **outputColumn** element.

2.7.1.1.1.1.4.1.1.2.1.1.19 Percentage Sampling Component outputColumn Element

The Percentage Sampling Component MUST NOT have any properties on the **outputColumn** element.

2.7.1.1.1.1.4.1.1.2.1.1.20 Pivot Component outputColumn Element

The Pivot Component **outputColumn** element MUST NOT use any **Name** attribute value on a **property** element except for those that are listed in the table in this section.

The following table specifies the **Name** attribute values that are allowed for the Pivot Component Task on the **outputColumn** element, in addition to any restrictions on the element value. These restrictions MUST be followed.

| Name attribute value | Description |
|----------------------|--|
| SourceColumn | An integer value that specifies the lineage identifier of the input column that contains a pivoted value. <52> |

| Name attribute value | Description |
|----------------------|---|
| PivotKeyValue | A string value that specifies one of the possible set of pivot keys that are identified in the input. |

2.7.1.1.1.1.4.1.1.2.1.1.21 RowCount Component outputColumn Element

The RowCount Component MUST NOT have any properties on the **outputColumn** element.

2.7.1.1.1.1.4.1.1.2.1.1.22 Row Sampling Component outputColumn Element

The Row Sampling Component **outputColumn** element MUST NOT use any **Name** attribute value on a **property** element except for those that are listed in the table in this section.

The following table specifies the **Name** attribute values that are allowed for Row Sampling Component on the **outputColumn** element, in addition to any restrictions on the element value. These restrictions MUST be followed.

| Name attribute value | Description |
|-----------------------------|--|
| InputColumnLineageID | An integer value that specifies the lineage identifier of the input column that is the source of this output column. |

2.7.1.1.1.1.4.1.1.2.1.1.23 Script Component outputColumn Element

The Script Component MUST NOT have any properties on the **outputColumn** element.

2.7.1.1.1.1.4.1.1.2.1.1.24 Slowly Changing Dimension Component outputColumn Element

The Slowly Changing Dimension Component MUST NOT have any properties on the **outputColumn** element.

2.7.1.1.1.1.4.1.1.2.1.1.25 Sort Component outputColumn Element

The Sort Component **outputColumn** element MUST NOT use any **Name** attribute value on a **property** element except for those that are listed in the table in this section.

The following table specifies the **Name** attribute values that are allowed for Sort Component on the **outputColumn** element, in addition to any restrictions on the element value. These restrictions MUST be followed.

| Name attribute value | Description |
|----------------------|--|
| SortColumnID | An integer value that specifies the lineage identifier of the sort column. |

2.7.1.1.1.1.4.1.1.2.1.1.26 Term Extraction Component outputColumn Element

The Term Extraction Component MUST NOT have any properties on the **outputColumn** element.

2.7.1.1.1.1.4.1.1.2.1.1.27 Term Lookup Component outputColumn Element

The Term Lookup Component **outputColumn** element MUST NOT use any **Name** attribute value on a **property** element except for those that are listed in the table in this section.

The following table specifies the **Name** attribute values that are allowed for Term Lookup Component on the **outputColumn** element, in addition to any restrictions on the element value. These restrictions MUST be followed.

| Name attribute value | Description |
|----------------------|---|
| CustomLineageID | An integer value that specifies the lineage identifier of the corresponding input column. |

2.7.1.1.1.1.4.1.1.2.1.1.28 Union All Component outputColumn Element

The Union All Component MUST NOT have any properties on the **outputColumn** element.

2.7.1.1.1.1.4.1.1.2.1.1.29 Unpivot Component outputColumn Element

The Unpivot Component **outputColumn** element MUST NOT use any **Name** attribute value on a **property** element except for those that are listed in the table in this section.

The following table specifies the **Name** attribute values that are allowed for Unpivot Component on the **outputColumn** element, in addition to any restrictions on the element value. These restrictions MUST be followed.

| Name attribute value | Description |
|----------------------|--|
| PivotKey | A Boolean value that specifies whether the PivotKeyValue property of input columns is written to this output column. TRUE specifies that the PivotKeyValue property of input columns is written to this output column. FALSE specifies that the PivotKeyValue property of input columns is not written to this output column. |

2.7.1.1.1.1.4.1.1.2.1.1.30 ADO.NET Source Component outputColumn Element

The ADO.NET Source Component MUST NOT have any properties on the **outputColumn** element.

2.7.1.1.1.1.4.1.1.2.1.1.31 Excel Source Component outputColumn Element

The Excel Source Component MUST NOT have any properties on the **outputColumn** element.

2.7.1.1.1.1.4.1.1.2.1.1.32 Flat File Source Component outputColumn Element

The Flat File Source Component **outputColumn** element MUST NOT use any **Name** attribute value on a **property** element except for those that are listed in the table in this section.

The following table specifies the **Name** attribute values that are allowed for Flat File Source Component on the **outputColumn** element, in addition to any restrictions on the element value. These restrictions MUST be followed.

| Name attribute value | Description |
|----------------------|---|
| FastParse | A Boolean value that specifies whether the component uses the faster, locale-insensitive parsing method. TRUE specifies that the faster, locale-insensitive parsing method is used. FALSE specifies that the faster, locale-insensitive parsing method is not used. |
| UseBinaryFormat | A Boolean value that specifies whether data from the source is in binary format. TRUE specifies that the data is in binary format. FALSE specifies that the data is not in binary format. |

2.7.1.1.1.1.4.1.1.2.1.1.33 OLE DB Source Component outputColumn Element

The OLE DB Source Component MUST NOT have any properties on the **outputColumn** element.

2.7.1.1.1.1.4.1.1.2.1.1.34 Raw File Source Component outputColumn Element

The Raw File Source Component MUST NOT have any properties on the **outputColumn** element.

2.7.1.1.1.1.4.1.1.2.1.1.35 XML Source Component outputColumn Element

The XML Source Component MUST NOT have any properties on the **outputColumn** element.

2.7.1.1.1.1.4.1.2 PipelineComponentOutputPropertiesType

The **PipelineComponentOutputPropertiesType** type specifies a collection of properties for an **output** element that is part of a Pipeline component.

The following is the XSD for the **PipelineComponentOutputPropertiesType** type.

```
<xs:complexType name="PipelineComponentOutputPropertiesType">
  <xs:sequence>
    <xs:element name="property" form="unqualified"
      type="DTS:PipelineComponentOutputPropertyType"
      minOccurs="0" maxOccurs="unbounded"/>
  </xs:sequence>
</xs:complexType>
```

The following table specifies the elements of the **PipelineComponentOutputPropertiesType** type.

| Element | Type definition | Description |
|-----------------|-------------------------------------|--|
| property | PipelineComponentOutputPropertyType | A complex type that specifies a single property within a collection of output properties for an output element of a Pipeline component. |

2.7.1.1.1.1.4.1.2.1 PipelineComponentOutputPropertyType

The **PipelineComponentOutputPropertyType** type specifies the structure in which the value for a single property of an output of a component is held. All outputs do not use the same set of properties, so this general structure is designed to hold the variety of properties that an output can have.

The following is the XSD for the **PipelineComponentOutputPropertyType** type.

```
<xs:complexType name="PipelineComponentOutputPropertyType"
  mixed="true">
  <xs:sequence>
    <xs:element name="arrayElements"
      type="DTS:PipelineComponentArrayElementsType"
      form="unqualified" minOccurs="0"/>
  </xs:sequence>
  <xs:attributeGroup
    ref="DTS:PipelineComponentPropertyAttributeGroup"/>
  <xs:attribute name="name"
    type="DTS:PipelineComponentOutputPropertyNameEnum"
    form="unqualified"/>
</xs:complexType>
```

The following table specifies the elements of the **PipelineComponentOutputPropertyType** type.

| Element | Type definition | Description |
|----------------------|--|---|
| arrayElements | PipelineComponentArrayElementsType | A complex type that contains a collection of elements that form an array. The collection constitutes the value for the property. This value is used only if the isArray attribute value is TRUE. |

The following table specifies the attributes of the **PipelineComponentOutputPropertyType** type.

| Attribute | Description |
|--|---|
| name | An enumeration value that specifies the name of the property. |
| PipelineComponentPropertyAttributeGroup | An attribute group that contains attributes that are common to all property elements for input elements, output elements, inputColumn elements, and outputColumn elements. |

2.7.1.1.1.4.1.3 PipelineComponentOutputPropertyNameEnum

The **PipelineComponentOutputPropertyNameEnum** type contains the allowed values for the **name** attribute on the **output** element of a component of a Pipeline Task executable. The allowed values for the **property** element for each task are more restricted than the values that are specified formally by the XSD.

Each **name** attribute value MUST NOT be used for any **output** element except for the components that are specified in the subsections to this section. Some components allow no properties on the **output** element.

The additional restrictions that are specified in the subsections to this section MUST be followed for the **name** attribute on the **property** element children of the **output** element.

The following is the XSD for the **PipelineComponentOutputPropertyNameEnum** type.

```
<xs:simpleType name="PipelineComponentOutputPropertyNameEnum">
  <xs:restriction base="xs:string">
    <!--Transforms-->
    <!--Aggregate Task-->
    <xs:enumeration value="KeyScale"/>
    <xs:enumeration value="Keys"/>
    <!--Audit (none)-->
    <!--Cache Transform (none)-->
    <!--Character Map (none)-->
    <!--Conditional Split-->
    <xs:enumeration value="Expression"/>
    <xs:enumeration value="FriendlyExpression"/>
    <xs:enumeration value="EvaluationOrder"/>
    <xs:enumeration value="IsDefaultOut"/>
    <!--Copy Column (none)-->
    <!--Data Conversion (none)-->
    <!--Data Mining Query(none)-->
    <!--Derived Column Query (none)-->
    <!--Export Column Query (none)-->
    <!--Fuzzy Grouping(none)-->
    <!--Fuzzy Lookup(none)-->
    <!--Import Column (none)-->
    <!--Lookup(none)-->
    <!--Merge (none)-->
    <!--MergeJoin (none)-->
    <!--Multicast (none)-->
    <!--OLE DB Command(none)-->
    <!--Percentage Sampling-->
```

```

<xs:enumeration value="Selected"/>
<!--Pivot (none)-->
<!--RowCount (none)-->
<!--Row Sampling-->
<xs:enumeration value="Selected"/>
<!--Script Component (none)-->
<!--Slowly Changing Dimension (none)-->
<!--Sort (none)-->
<!--Term Extraction (none)-->
<!--Term Lookup (none)-->
<!--UnionAll (none)-->
<!--Unpivot (none)-->
<!--Data Sources (none)-->
<!--ADO.Net Source (none)-->
<!--Excel Source (none)-->
<!--Flat File Source (none)-->
<!--OLEDB Source Task (none)-->
<!--Raw File Source (none)-->
<!--XML Source-->
<xs:enumeration value="RowsetID"/>
</xs:restriction>
</xs:simpleType>

```

2.7.1.1.1.4.1.3.1 **Aggregate Component output Element**

The Aggregate Component **output** element MUST NOT use any **Name** attribute value on a **property** element except for those that are listed in the table in this section.

The following table specifies the **Name** attribute values that are allowed for the Aggregate Component, in addition to any restrictions on the element value. These restrictions MUST be followed.

| Name attribute value | Description |
|----------------------|---|
| KeyScale | An integer value that specifies the approximate number of groups expected by the operation. This value is used to optimize computation. The enumeration values are interpreted as follows: 0 – The key scale is not used. 1 – The aggregation writes approximately 500,000 keys. 2 – The aggregation writes approximately 25,000,000 keys. 3 – The aggregation writes more than 25,000,000 keys |
| Keys | An integer value that specifies the exact number of GroupBy keys that can be written. If this value is specified, it takes precedence over the value of the KeyScale attribute. |

2.7.1.1.1.4.1.3.2 **Audit Component output Element**

The Audit Component **output** element MUST NOT have any properties.

2.7.1.1.1.4.1.3.3 **Cache Transform Component output Element**

The Cache Transform Component **output** element MUST NOT have any properties.

2.7.1.1.1.4.1.3.4 **Character Map Component output Element**

The Character Map Component **output** element MUST NOT have any properties.

2.7.1.1.1.4.1.3.5 **Conditional Split Component output Element**

The Conditional Split Component **output** element MUST NOT use any **Name** attribute value on a **property** element except for those that are listed in the table in this section.

The following table specifies the **Name** attribute values that are allowed for Conditional Split Component, in addition to any restrictions on the element value. These restrictions MUST be followed.

| Name attribute value | Description |
|---------------------------|--|
| Expression | A string value that specifies a conditional expression that is evaluated to determine the conditional split. |
| FriendlyExpression | A string value that specifies a conditional expression that is evaluated to determine the conditional split. The FriendlyExpression attribute uses column names in the expression syntax, while the Expression attribute uses only column lineage identifiers. |
| EvaluationOrder | An integer value that specifies the order in which the expression is evaluated, from lowest to highest. |
| IsDefaultOut | A Boolean value that specifies whether an output is the default output. TRUE specifies that the output is the default output. FALSE specifies that the output is not the default output. |

2.7.1.1.1.1.4.1.3.6 Copy Column Component output Element

The Copy Column Component **output** element MUST NOT have any properties.

2.7.1.1.1.1.4.1.3.7 Data Conversion Component output Element

The Data Conversion Component **output** element MUST NOT have any properties.

2.7.1.1.1.1.4.1.3.8 Data Mining Query Component output Element

The Data Mining Query Component **output** element MUST NOT have any properties.

2.7.1.1.1.1.4.1.3.9 Derived Column Component output Element

The Derived Column Component **output** element MUST NOT have any properties.

2.7.1.1.1.1.4.1.3.10 Export Column Component output Element

The Export Column Component **output** element MUST NOT have any properties.

2.7.1.1.1.1.4.1.3.11 Fuzzy Grouping Component output Element

The Fuzzy Grouping Component **output** element MUST NOT have any properties.

2.7.1.1.1.1.4.1.3.12 Fuzzy Lookup Component output Element

The Fuzzy Lookup Component **output** element MUST NOT have any properties.

2.7.1.1.1.1.4.1.3.13 Import Column Component output Element

The Import Column Component **output** element MUST NOT have any properties.

2.7.1.1.1.1.4.1.3.14 Lookup Component output Element

The Lookup Component **output** element MUST NOT have any properties.

2.7.1.1.1.1.4.1.3.15 Merge Component output Element

The Merge Component **output** element MUST NOT have any properties.

2.7.1.1.1.1.4.1.3.16 MergeJoin Component output Element

The MergeJoin Component **output** element MUST NOT have any properties.

2.7.1.1.1.1.4.1.3.17 Multicast Component output Element

The Multicast Component **output** element MUST NOT have any properties.

2.7.1.1.1.1.4.1.3.18 OLE DB Command Component output Element

The OLE DB Command Component **output** element MUST NOT have any properties.

2.7.1.1.1.1.4.1.3.19 Percentage Sampling Component output Element

The Percentage Sampling Component **output** element MUST NOT use any **Name** attribute value on a **property** element except for those that are listed in the table in this section.

The following table specifies the **Name** attribute values that are allowed for Percentage Sampling Component, in addition to any restrictions on the element value. These restrictions MUST be followed.

| Name attribute value | Description |
|-----------------------------|---|
| Selected | A Boolean value that specifies to which output sampled output is directed. TRUE specifies that sampled output is directed to this output. FALSE specifies that sampled output is not directed to this output. |

2.7.1.1.1.1.4.1.3.20 Pivot Component output Element

The Pivot Component **output** element MUST NOT have any properties.

2.7.1.1.1.1.4.1.3.21 RowCount Component output Element

The RowCount Component **output** element MUST NOT have any properties.

2.7.1.1.1.1.4.1.3.22 Row Sampling Component output Element

The Row Sampling Component **output** element MUST NOT use any **Name** attribute value on a **property** element except for those that are listed in the table in this section.

The following table specifies the **Name** attribute values that are allowed for Row Sampling Component, in addition to any restrictions on the element value. These restrictions MUST be followed.

| Name attribute value | Description |
|-----------------------------|---|
| Selected | A Boolean value that specifies to which output sampled output is directed. TRUE specifies that sampled output is directed to this output. FALSE specifies that sampled output is not directed to this output. |

2.7.1.1.1.1.4.1.3.23 Script Component output Element

The Script Component **output** element MUST NOT have any properties.

2.7.1.1.1.1.4.1.3.24 Slowly Changing Dimension Component output Element

The Slowly Changing Dimension Component **output** element MUST NOT have any properties.

2.7.1.1.1.1.4.1.3.25 Sort Component output Element

The Sort Component **output** element MUST NOT have any properties.

2.7.1.1.1.1.4.1.3.26 Term Extraction Component output Element

The Term Extraction Component **output** element MUST NOT have any properties.

2.7.1.1.1.1.4.1.3.27 Term Lookup Component output Element

The Term Lookup Component **output** element MUST NOT have any properties.

2.7.1.1.1.1.4.1.3.28 Union All Component output Element

The Union All Component **output** element MUST NOT have any properties.

2.7.1.1.1.1.4.1.3.29 Unpivot Component output Element

The Unpivot Component **output** element MUST NOT have any properties.

2.7.1.1.1.1.4.1.3.30 ADO.NET Source Component output Element

The ADO.NET Source Component **output** element MUST NOT have any properties.

2.7.1.1.1.1.4.1.3.31 Excel Source Component output Element

The Excel Source Component **output** element MUST NOT have any properties.

2.7.1.1.1.1.4.1.3.32 Flat File Source Component output Element

The Flat File Source Component **output** element MUST NOT have any properties.

2.7.1.1.1.1.4.1.3.33 OLE DB Source Component output Element

The OLE DB Source Component **output** element MUST NOT have any properties.

2.7.1.1.1.1.4.1.3.34 Raw File Source Component output Element

The Raw File Source Component **output** element MUST NOT have any properties.

2.7.1.1.1.1.4.1.3.35 XML Source Component output Element

The XML Source Component **output** element MUST NOT use any **Name** attribute value on a **property** element except for those that are listed in the table in this section.

The following table specifies the **Name** attribute values that are allowed for the XML Source Task, in addition to any restrictions on the element value. These restrictions MUST be followed.

| Name attribute value | Description |
|-----------------------------|--|
| RowsetID | A string value that specifies the name of the rowset that is associated with the output. |

2.7.1.1.1.1.5 PipelineComponentComponentClassIDEnum

The **PipelineComponentComponentClassIDEnum** type contains the enumeration values for the **componentClassID** attribute.

The following is the XSD for the **PipelineComponentComponentClassIDEnum** type.

```
<xs:simpleType name="PipelineComponentComponentClassIDEnum">
  <xs:restriction base="DTS:uuid">
    <!--Transforms-->
    <!--Aggregate-->
    <xs:enumeration value="{9ABE8DF3-0052-42DB-8B18-2089E1D1D1B7}"/>
    <!--Audit-->
    <xs:enumeration value="{32711D35-7D9D-44E5-B57E-A17D33D5C38C}"/>
  </xs:restriction>
</xs:simpleType>
```

```

<!--Cache Transform-->
<xs:enumeration value="{A236DD44-4409-433E-A1CE-283DA18F4E0F}"/>
<!--Character Map-->
<xs:enumeration value="{DEC33219-BA68-4FEB-AC98-9C1B1E577A8D}"/>
<!--Conditional Split-->
<xs:enumeration value="{3AE878C6-0D6C-4F48-8128-40E00E9C1B7D}"/>
<!--Copy Column-->
<xs:enumeration value="{98F16A65-E02F-4B0F-87D4-C217EA074619}"/>
<!--Data Conversion-->
<xs:enumeration value="{BD06A22E-BC69-4AF7-A69B-C44C2EF684BB}"/>
<!--Data Mining Query-->
<xs:enumeration value="{9C58B013-AF30-455F-B809-50F425AFBCAC}"/>
<!--Derived Column-->
<xs:enumeration value="{2932025B-AB99-40F6-B5B8-783A73F80E24}"/>
<!--Export Column-->
<xs:enumeration value="{86151302-DCDB-49FB-92FE-772EC02712B6}"/>
<!--Fuzzy Grouping-->
<xs:enumeration value="{0A1BDBA0-9C6E-4AD7-97B1-E0E79E462629}"/>
<!--Fuzzy Lookup-->
<xs:enumeration value="{5056651F-F227-4978-94DF-53CDF9E8CCB6}"/>
<!--Import Column-->
<xs:enumeration value="{C8AE54-67A0-41A8-821D-D1C8BED62C68}"/>
<!--Lookup-->
<xs:enumeration value="{27648839-180F-45E6-838D-AFF53DF682D2}"/>
<!--Merge-->
<xs:enumeration value="{D3FC84FA-748F-40B4-A967-F1574F917BE5}"/>
<!--MergeJoin-->
<xs:enumeration value="{A18A4D58-7C7A-4448-8B98-AE2CEFE81B4C}"/>
<!--Multicast-->
<xs:enumeration value="{1ACA4459-ACE0-496F-814A-8611F9C27E23}"/>
<!--OLE DB Command-->
<xs:enumeration value="{8E61C8F6-C91D-43B6-97EB-3423C06571CC}"/>
<!--Percentage Sampling-->
<xs:enumeration value="{CEFE125-5BB5-4F91-A349-94B8961C641B}"/>
<!--Pivot-->
<xs:enumeration value="{DD5A6456-8430-422B-9F50-7EF5A1B63CA8}"/>
<!--RowCount-->
<xs:enumeration value="{150E6007-7C6A-4CC3-8FF3-FC73783A972E}"/>
<!--Row Sampling-->
<xs:enumeration value="{A44C46A3-0A3F-454B-B3BD-0BC23D4BCE94}"/>
<!--Script Component, ADO.Net source, XML Source,ADO.Net
Destination, DataReader Destination, SQL Server Compact Destination-->
<xs:enumeration value="{2E42D45B-F83C-400F-8D77-61DDE6A7DF29}"/>
<!--Slowly Changing Dimension-->
<xs:enumeration value="{70909A92-ECE9-486D-B17E-30EDE908849E}"/>
<!--Sort-->
<xs:enumeration value="{07127A7C-164B-422A-AD1F-24BE39B4DB38}"/>
<!--Term Extraction-->
<xs:enumeration value="{119D450D-E2A3-4DB0-A7BC-ACDE2536673E}"/>
<!--Term Lookup-->
<xs:enumeration value="{4CC3A325-9885-48B4-B451-147C2D523646}"/>
<!--Union All-->
<xs:enumeration value="{4D9F9B7C-84D9-4335-ADB0-2542A7E35422}"/>
<!--Unpivot-->
<xs:enumeration value="{8F25687E-2ACA-4EF3-88A3-53099FDAAAF43}"/>
<!--Destinations-->
<!--Excel Destination-->
<xs:enumeration value="{C9269E28-EBDE-4DED-91EB-0BF42842F9F4}"/>
<!--Flat File Destination-->
<xs:enumeration value="{D658C424-8CF0-441C-B3C4-955E183B7FBA}"/>
<!--OLE DB Destination-->
<xs:enumeration value="{5A0B62E8-D91D-49F5-94A5-7BE58DE508F0}"/>
<!--Data Mining Model Training-->
<xs:enumeration value="{0183D6BA-8792-4602-A6AB-6DF19E7F9979}"/>
<!--Dimension Processing-->
<xs:enumeration value="{7D1B6DD6-C1A9-416E-9E7F-31400E3F7249}"/>
<!--Partition Processing-->
<xs:enumeration value="{DCDA2491-C4A4-4C84-9253-119AEF1A4CD7}"/>
<!--Raw File Destination-->

```

```

<xs:enumeration value="{485E7329-8754-42B4-AA5B-29C5DA09CAD5}"/>
<!--RecordSet Destination-->
<xs:enumeration value="{167AF7E9-BA81-425F-B73D-E30C2DCC0F09}"/>
<!--SQL Server Destination-->
<xs:enumeration value="{E4B61516-847B-4BDF-9CC6-1968A2D43E73}"/>
<!--Sources-->
<!--Excel Source-->
<xs:enumeration value="{A4B1E1C8-17F3-46C8-AAD0-34F0C6FE42DE}"/>
<!--Flat File Source-->
<xs:enumeration value="{5ACD952A-F16A-41D8-A681-713640837664}"/>
<!--OLE DB Source-->
<xs:enumeration value="{BCEFE59B-6819-47F7-A125-63753B33ABB7}"/>
<!--Raw File Source-->
<xs:enumeration value="{51DC0B24-7421-45C3-B4AB-9481A683D91D}"/>
</xs:restriction>
</xs:simpleType>

```

The following table specifies the enumeration values for the **PipelineComponentComponentClassIDEnum** type.

| Enumeration value | Description |
|--|-------------------------------|
| {9ABE8DF3-0052-42DB-8B18-2089E1D1D1B7} | Aggregate Component |
| {32711D35-7D9D-44E5-B57E-A17D33D5C38C} | Audit Component |
| {A236DD44-4409-433E-A1CE-283DA18F4E0F} | Cache Transform Component |
| {DEC33219-BA68-4FEB-AC98-9C1B1E577A8D} | Character Map Component |
| {3AE878C6-0D6C-4F48-8128-40E00E9C1B7D} | Conditional Split Component |
| {98F16A65-E02F-4B0F-87D4-C217EA074619} | Copy Column Component |
| {BD06A22E-BC69-4AF7-A69B-C44C2EF684BB} | Data Conversion Component |
| {9C58B013-AF30-455F-B809-50F425AFBCAC} | Data Mining Query Component |
| {2932025B-AB99-40F6-B5B8-783A73F80E24} | Derived Column Component |
| {86151302-DCDB-49FB-92FE-772EC02712B6} | Export Column Component |
| {0A1BDBA0-9C6E-4AD7-97B1-E0E79E462629} | Fuzzy Grouping Component |
| {5056651F-F227-4978-94DF-53CDF9E8CCB6} | Fuzzy Lookup Component |
| {C8AE5E54-67A0-41A8-821D-D1C8BED62C68} | Import Column Component |
| {27648839-180F-45E6-838D-AFF53DF682D2} | Lookup Component |
| {D3FC84FA-748F-40B4-A967-F1574F917BE5} | Merge Component |
| {A18A4D58-7C7A-4448-8B98-AE2CEFE81B4C} | MergeJoin Component |
| {1ACA4459-ACE0-496F-814A-8611F9C27E23} | Multicast Component |
| {8E61C8F6-C91D-43B6-97EB-3423C06571CC} | OLE DB Command Component |
| {CEFE125-5BB5-4F91-A349-94B8961C641B} | Percentage Sampling Component |
| {DD5A6456-8430-422B-9F50-7EF5A1B63CA8} | Pivot Component |
| {150E6007-7C6A-4CC3-8FF3-FC73783A972E} | RowCount Component |

| Enumeration value | Description |
|--|---|
| {A44C46A3-0A3F-454B-B3BD-0BC23D4BCE94} | Row Sampling Component |
| {2E42D45B-F83C-400F-8D77-61DDE6A7DF29}<53> | <ul style="list-style-type: none"> ▪ Script Component ▪ ADO.Net Source Component ▪ XML Source Component ▪ ADO.Net Destination Component ▪ DataReader Destination Component ▪ SQL Server Compact Destination Component |
| {70909A92-ECE9-486D-B17E-30EDE908849E} | Slowly Changing Dimension Component |
| {07127A7C-164B-422A-AD1F-24BE39B4DB38} | Sort Component |
| {119D450D-E2A3-4DB0-A7BC-ACDE2536673E} | Term Extraction Component |
| {4CC3A325-9885-48B4-B451-147C2D523646} | Term Lookup Component |
| {4D9F9B7C-84D9-4335-ADB0-2542A7E35422} | Union All Component |
| {8F25687E-2ACA-4EF3-88A3-53099FDAAF43} | Unpivot Component |
| {C9269E28-EBDE-4DED-91EB-0BF42842F9F4} | Excel Destination Component |
| {D658C424-8CF0-441C-B3C4-955E183B7FBA} | Flat File Destination Component |
| {5A0B62E8-D91D-49F5-94A5-7BE58DE508F0} | OLE DB Destination Component |
| {0183D6BA-8792-4602-A6AB-6DF19E7F9979} | Data Mining Model Training Destination Component |
| {7D1B6DD6-C1A9-416E-9E7F-31400E3F7249} | Dimension Processing Destination Component |
| {DCDA2491-C4A4-4C84-9253-119AEF1A4CD7} | Partition Processing Destination Component |
| {485E7329-8754-42B4-AA5B-29C5DA09CAD5} | Raw File Destination Component |
| {167AF7E9-BA81-425F-B73D-E30C2DCC0F09} | RecordSet Destination Component |
| {E4B61516-847B-4BDF-9CC6-1968A2D43E73} | SQL Server Destination Component |
| {A4B1E1C8-17F3-46C8-AAD0-34F0C6FE42DE} | Excel Source Component |
| {5ACD952A-F16A-41D8-A681-713640837664} | Flat File Source Component |
| {BCEFE59B-6819-47F7-A125-63753B33ABB7} | OLE DB Source Component |
| {51DC0B24-7421-45C3-B4AB-9481A683D91D} | Raw File Source Component |

2.7.1.1.1.1.6 Attribute Groups and Common Types Used by Components

The following sections specify attribute groups and other types that are referenced by type definitions within the Pipeline component's hierarchy of types.

2.7.1.1.1.1.6.1 PipelineComponentMetadataColumnsType

The **PipelineComponentMetadataColumnsType** type specifies a collection of external metadata column objects for an **input** element or an **output** element of a Pipeline Task executable.

The following is the XSD for the **PipelineComponentMetadataColumnsType** type.

```
<xs:complexType name="PipelineComponentMetadataColumnsType">
  <xs:sequence>
    <xs:element name="externalMetadataColumn"
      type="DTS:PipelineComponentMetadataColumnType"
      minOccurs="0" maxOccurs="unbounded" form="unqualified"/>
  </xs:sequence>
  <xs:attribute name="isUsed" form="unqualified">
    <xs:simpleType>
      <xs:restriction base="xs:string">
        <xs:enumeration value="True"/>
        <xs:enumeration value="False"/>
      </xs:restriction>
    </xs:simpleType>
  </xs:attribute>
</xs:complexType>
```

The following table specifies the elements of the **PipelineComponentMetadataColumnsType** type.

| Element | Type description | Description |
|-------------------------------|---|--|
| externalMetadataColumn | PipelineComponentMetadataColumnType | A complex type that specifies a single metadata column definition within an input or an output of a Pipeline Task. |

The following table specifies the attributes of the **PipelineComponentMetadataColumnsType** type.

| Attribute group | Description |
|-----------------|--|
| isUsed | An enumeration value that specifies whether external metadata columns are used. "True" specifies that external metadata columns are used. "False" specifies that external metadata columns are not used. |

2.7.1.1.1.6.1.1 PipelineComponentMetadataColumnType

The **PipelineComponentMetadataColumnType** type specifies a single column that is a member of a collection of metadata columns that are part of a Pipeline component.

The following is the XSD for the **PipelineComponentMetadataColumnType** type.

```
<xs:complexType name="PipelineComponentMetadataColumnType">
  <xs:sequence>
    <xs:element name="properties"
      type="DTS:PipelineComponentMetadataColumnPropertiesType"
      minOccurs="0" form="unqualified"/>
  </xs:sequence>
  <xs:attributeGroup
    ref="DTS:PipelineComponentAllColumnBaseAttributeGroup"/>
  <xs:attributeGroup
    ref="DTS:PipelineComponentColumnExtendedAttributeGroup"/>
</xs:complexType>
```

The following table specifies the elements of the **PipelineComponentMetadataColumnType** type.

| Element | Type definition | Description |
|-------------------|---|--|
| properties | PipelineComponentMetadataColumnPropertiesType | A complex type that specifies a collection of properties of a metadata column. |

The following table specifies the attribute groups of the **PipelineComponentMetadataColumnType** type.

| Attribute group | Description |
|--|---|
| PipelineComponentAllColumnBaseAttributeGroup | An attribute group specification that specifies attributes that are common to all types of columns for Pipeline components. |
| PipelineComponentColumnExtendedAttributeGroup | An attribute group specification that specifies additional attributes that are present for the PipelineComponentMetadataColumnType type. |

2.7.1.1.1.6.1.1.1 PipelineComponentMetadataColumnPropertiesType

The **PipelineComponentMetadataColumnPropertiesType** type specifies a collection of properties for an **externalMetadataColumn** element that is part of a Pipeline component.

The following is the XSD for the **PipelineComponentMetadataColumnPropertiesType** type.

```
<xs:complexType name="PipelineComponentMetadataColumnPropertiesType">
  <xs:sequence>
    <xs:element name="property"
      type="DTS:PipelineComponentMetadataColumnPropertyType"
      minOccurs="0" maxOccurs="unbounded" form="unqualified"/>
  </xs:sequence>
</xs:complexType>
```

The following table specifies the elements of the **PipelineComponentMetadataColumnPropertiesType** type.

| Element | Type definition | Description |
|-----------------|---|---|
| property | PipelineComponentMetadataColumnPropertyType | A complex type that specifies a single property within a collection of metadata column properties for an externalMetadataColumn element of a Pipeline component. |

2.7.1.1.1.6.1.1.1.1 PipelineComponentMetadataColumnPropertyType

The **PipelineComponentMetadataColumnPropertyType** type specifies a property of an **inputColumn** element.

The following is the XSD for the **PipelineComponentMetadataColumnPropertyType** type.

```
<xs:complexType name="PipelineComponentMetadataColumnPropertyType">
  <xs:simpleContent>
    <xs:extension base="xs:anySimpleType">
      <xs:attributeGroup
        ref="DTS:PipelineComponentPropertyAttributeGroup"/>
      <xs:attribute name="name" form="unqualified" />
    </xs:extension>
  </xs:simpleContent>
</xs:complexType>
```

```

        type="DTS:PipelineComponentMetadataColumnNameEnum"/>
    </xs:extension>
</xs:simpleContent>
</xs:complexType>

```

The following table specifies the attributes and attribute groups of the **PipelineComponentMetadataColumnNamePropertyType** type.

| Attribute | Description |
|--|---|
| PipelineComponentPropertyAttributeGroup | An attribute group that contains attributes that are common to all property elements for input elements, output elements, inputColumn elements, and outputColumn elements. |
| name | A string value that specifies the name of the property. |

2.7.1.1.1.1.6.1.1.1.1.1 **PipelineComponentMetadataColumnNameEnum**

The **PipelineComponentMetadataColumnNameEnum** type contains the allowed values for the **name** attribute on the **externalMetadataColumn** element of a Pipeline component. The allowed values for the **property** element for each task are more restricted than the values that are specified formally by the XSD.

Each **name** attribute value MUST NOT be used for any component except for the components that are specified in the subsections to this section. Some components allow no properties.

The additional restrictions specified in the subsections to this section MUST be followed for the **name** attribute on the **property** element children of the **externalMetadataColumn** element.

The following is the XSD of the **PipelineComponentMetadataColumnNameEnum** type.

```

<xs:simpleType name="PipelineComponentMetadataColumnNameEnum">
  <xs:restriction base="xs:string">
    <!--OLE DB Command-->
    <xs:enumeration value="DBParamInfoFlags"/>
    <!--XML Source-->
    <xs:enumeration value="CLRType"/>
  </xs:restriction>
</xs:simpleType>

```

2.7.1.1.1.1.6.1.1.1.1.2 **OLE DB Command Component**

The OLE DB Command Component **externalMetadataColumn** element MUST NOT use any **Name** attribute value on a child **property** element except for those that are listed in the table in this section.

The following table specifies the **Name** attribute values that are allowed for OLE DB Command Component on the **externalMetadataColumn** element, in addition to any restrictions on the element value. These restrictions MUST be followed.

| Name attribute value | Description |
|-------------------------|---|
| DBParamInfoFlags | An integer value that is a bitmask that specifies characteristics of a parameter. The interpretation of the bits in the bitmask is as follows: 0x00000001 – The parameter accepts values on input. 0x00000002 – The parameter returns values on output. |

| Name attribute value | Description |
|----------------------|---|
| | 0x00000010 – The parameter is signed. 0x00000040 – The parameter accepts NULL values. 0x00000080 – The parameter is a binary large object (BLOB). 0x00000100 – The parameter value represents the absolute value of the negative scale of the parameter. |

2.7.1.1.1.1.6.1.1.1.3 XML Source Component

The XML Source Component **externalMetadataColumn** element MUST NOT use any **Name** attribute value on a child **property** element except for those that are listed in the table in this section.

The following table specifies the **Name** attribute values that are allowed for XML Source Component on the **externalMetadataColumn** element, in addition to any restrictions on the element value. These restrictions MUST be followed.

| Name attribute value | Description |
|----------------------|---|
| CLRType | A string value that specifies the type of the column, in terms of the CLR type system. The allowed string values are the following: System.Boolean – Boolean. System.Byte – Byte. System.SByte – 8-bit signed integer. System.Char – Unicode character. System.Decimal – Decimal number. System.Double – Double precision real number. System.Single – Single precision real number. System.Int32 – 32-bit integer. System.UInt32 – Unsigned 32-bit integer. System.Int64 – 64-bit integer. System.UInt64 – Unsigned 64-bit integer. System.Object – Object. System.Int16 -16-bit integer. System.UInt16 – Unsigned 16-bit integer. System.String – Unicode character string. For more information about .NET Framework system types, see [MSDN-TYPCLS] . |

2.7.1.1.1.1.6.2 PipelineComponentRowDispositionEnum

The **PipelineComponentRowDispositionEnum** type contains the enumeration values for the **state** attribute.

The following is the XSD for the **PipelineComponentRowDispositionEnum** type.

```

<xs:simpleType name="PipelineComponentRowDispositionEnum">
  <xs:restriction base="xs:string">
    <xs:enumeration value="NotUsed"/>
    <xs:enumeration value="IgnoreFailure"/>
    <xs:enumeration value="FailComponent"/>
  </xs:restriction>
</xs:simpleType>

```

```

    <xs:enumeration value="RedirectRow"/>
  </xs:restriction>
</xs:simpleType>

```

The following table specifies the enumeration values for the **PipelineComponentRowDispositionEnum** type.

| Enumeration value | Description |
|----------------------|---|
| NotUsed | Specifies that row processing is not used. |
| IgnoreFailure | Specifies that the component ignores the failure and continue processing. |
| FailComponent | Specifies that the component's execution fails. |
| RedirectRow | Specifies that any row that causes a failure is redirected to the error output. |

2.7.1.1.1.1.6.3 PipelineComponentInputOutputElementAttributeGroup

The **PipelineComponentInputOutputElementAttributeGroup** attribute group specifies attributes that are used in common by the **input** element and the **output** element of the Pipeline component.

The following is the XSD for the **PipelineComponentInputOutputElementAttributeGroup** attribute group.

```

<xs:attributeGroup
  name="PipelineComponentInputOutputElementAttributeGroup">
  <xs:attribute name="id" type="xs:int" form="unqualified"/>
  <xs:attribute name="name" type="xs:string" form="unqualified"/>
  <xs:attribute name="description" type="xs:string"
    form="unqualified"/>
  <xs:attribute name="hasSideEffects" type="xs:boolean"
    form="unqualified"/>
  <xs:attribute name="dangling" type="xs:boolean"
    form="unqualified"/>
  <xs:attribute name="errorOrTruncationOperation" type="xs:string"
    form="unqualified"/>
  <xs:attribute name="errorRowDisposition" form="unqualified"
    type="DTS:PipelineComponentRowDispositionEnum"/>
  <xs:attribute name="truncationRowDisposition" form="unqualified"
    type="DTS:PipelineComponentRowDispositionEnum" />
</xs:attributeGroup>

```

The following table specifies additional information for the attributes of the **PipelineComponentInputOutputElementAttributeGroup** attribute group.

| Attribute | Description |
|-----------------------|--|
| id | An integer value that specifies an identifier for this column element. Other elements can refer to this column by using this id value. |
| name | A string value that specifies the name for this column element. |
| description | A string value that specifies the description for this component output element. |
| hasSideEffects | A Boolean value that indicates whether a component can be removed from the execution plan of the data flow when it is not attached to an upstream component and when the value of the RunInOptimizedMode attribute is |

| Attribute | Description |
|-----------------------------------|---|
| | TRUE. TRUE indicates that the component cannot be removed from the execution plan when it is not attached to an upstream component and when the RunInOptimizedMode attribute of the Pipeline element is TRUE. FALSE indicates that the component can be removed from the execution plan when it is not attached to an upstream component and when the RunInOptimizedMode attribute of the Pipeline element is TRUE. |
| dangling | A Boolean value that specifies whether the output is dangling, that is, that it does not lead to another component . TRUE specifies that the output is dangling. FALSE specifies that the output is not dangling. |
| errorOrTruncationOperation | A string value that specifies a string that can be displayed by the user interface to indicate the type of operation that causes an error or truncation operation to occur. |
| errorRowDisposition | An enumeration value that specifies the handling of row errors. |
| TruncationRowDisposition | An enumeration value that specifies the handling of truncations that occur when processing rows. |

2.7.1.1.1.1.6.4 PipelineComponentAllColumnBaseAttributeGroup

The **PipelineComponentAllColumnBaseAttributeGroup** attribute group specifies the attributes that are used for all columns that are specified by components.

The following is the XSD for the **PipelineComponentAllColumnBaseAttributeGroup** attribute group.

```
<xs:attributeGroup name="PipelineComponentAllColumnBaseAttributeGroup">
  <xs:attribute name="id" type="xs:int" form="unqualified"/>
  <xs:attribute name="name" type="xs:string" form="unqualified"/>
  <xs:attribute name="description" type="xs:string" form="unqualified"/>
  <xs:attribute name="mappedColumnId" type="xs:int" form="unqualified"/>
</xs:attributeGroup>
```

The following table specifies additional information for the attributes of the **PipelineComponentAllColumnBaseAttributeGroup** attribute group.

| Attribute | Description |
|-----------------------|---|
| id | An integer value that specifies an identifier for this column element. Other elements can refer to this column by using this id value. |
| name | A string value that specifies the name for this column element. |
| description | A string value that specifies the description for this column element. |
| mappedColumnId | An integer value that specifies the ID of a column that is mapped to this column. |

2.7.1.1.1.1.6.5 PipelineComponentIOColumnBaseAttributeGroup

The **PipelineComponentIOColumnBaseAttributeGroup** attribute group specifies the attributes that are used for all columns that serve as input columns or output columns that are specified by components.

The following is the XSD for the **PipelineComponentIOColumnBaseAttributeGroup** attribute group.

```
<xs:attributeGroup name="PipelineComponentIOColumnBaseAttributeGroup">
  <xs:attribute name="errorOrTruncationOperation" type="xs:string"
    form="unqualified"/>
  <xs:attribute name="errorRowDisposition"
    type="DTS:PipelineComponentRowDispositionEnum"
    form="unqualified"/>
  <xs:attribute name="truncationRowDisposition"
    type="DTS:PipelineComponentRowDispositionEnum"
    form="unqualified"/>
  <xs:attribute name="externalMetadataColumnId" type="xs:int"
    form="unqualified"/>
  <xs:attribute name="lineageId" type="xs:int" form="unqualified"/>
</xs:attributeGroup>
```

The following table specifies additional information for the attributes of the **PipelineComponentIOColumnBaseAttributeGroup** attribute group.

| Attribute | Description |
|-----------------------------------|---|
| errorOrTruncationOperation | A string value that specifies a string that can be displayed by the user interface to indicate the type of operation that causes an error or truncation operation to occur. |
| errorRowDisposition | An enumeration value that specifies the handling of row errors. |
| truncationRowDisposition | An enumeration value that specifies the handling of truncations that occur when processing rows. |
| externalMetadataColumnId | An integer value that specifies the identifier of the external metadata column for this column. |
| lineageId | An integer value. <54> |

2.7.1.1.1.1.6.6 PipelineComponentColumnExtendedAttributeGroup

The **PipelineComponentColumnExtendedAttributeGroup** attribute group specifies additional attributes that are used for some columns that are specified within components.

The following is the XSD for the **PipelineComponentColumnExtendedAttributeGroup** attribute group.

```
<xs:attributeGroup name="PipelineComponentColumnExtendedAttributeGroup">
  <xs:attribute name="precision" type="xs:int" form="unqualified"/>
  <xs:attribute name="scale" type="xs:int" form="unqualified"/>
  <xs:attribute name="length" type="xs:int" form="unqualified"/>
  <xs:attribute name="dataType"
    type="DTS:PipelineComponentColumnDataTypeEnum"
    form="unqualified"/>
  <xs:attribute name="codePage" type="xs:int" form="unqualified"/>
</xs:attributeGroup>
```

The following table specifies additional information for the attributes of the **PipelineComponentColumnExtendedAttributeGroup** attribute group.

| Attribute | Description |
|------------------|---|
| precision | An integer value that specifies the total digits in a numeric data type. |
| scale | An integer value that specifies the number of digits to the right of the decimal point. |
| length | An integer value that specifies the length of the column in characters. |
| dataType | An enumeration value that specifies the type of the data in the column. |
| codePage | An integer value that specifies the numeric value of the ANSI code page that is used for strings for this column. |

2.7.1.1.1.6.6.1 PipelineComponentColumnDataTypeEnum

The **PipelineComponentColumnDataTypeEnum** type contains the enumeration values for the **DataType** attribute as it appears within the different types of column elements.

The following is the XSD for the **PipelineComponentColumnDataTypeEnum** type.

```
<xs:simpleType name="PipelineComponentColumnDataTypeEnum">
  <xs:restriction base="xs:string">
    <xs:enumeration value="i1"/>
    <xs:enumeration value="ui1"/>
    <xs:enumeration value="i2"/>
    <xs:enumeration value="i4"/>
    <xs:enumeration value="r4"/>
    <xs:enumeration value="r8"/>
    <xs:enumeration value="cy"/>
    <xs:enumeration value="date"/>
    <xs:enumeration value="bool"/>
    <xs:enumeration value="variant"/>
    <xs:enumeration value="decimal"/>
    <xs:enumeration value="ui2"/>
    <xs:enumeration value="ui4"/>
    <xs:enumeration value="i8"/>
    <xs:enumeration value="ui8"/>
    <xs:enumeration value="guid"/>
    <xs:enumeration value="bytes"/>
    <xs:enumeration value="str"/>
    <xs:enumeration value="wstr"/>
    <xs:enumeration value="numeric"/>
    <xs:enumeration value="dbDate"/>
    <xs:enumeration value="dateTime"/>
    <xs:enumeration value="dbTime"/>
    <xs:enumeration value="dbTimeStamp"/>
    <xs:enumeration value="image"/>
    <xs:enumeration value="text"/>
    <xs:enumeration value="nText"/>
    <xs:enumeration value="dbTime2"/>
    <xs:enumeration value="dbTimeStamp2"/>
    <xs:enumeration value="dbTimeStampOffset"/>
  </xs:restriction>
</xs:simpleType>
```

The following table specifies the enumeration values for the **PipelineComponentColumnDataTypeEnum** type.

| Enumeration value | Description |
|--------------------------|--|
| i1 | One-byte integer. |
| ui1 | One-byte unsigned integer. |
| i2 | Two-byte integer. |
| i4 | Four-byte integer. |
| r4 | Four-byte real number. |
| r8 | Eight-byte real number. |
| cy | Calendar year. |
| date | Date. |
| bool | Boolean. |
| variant | Variant. |
| decimal | Decimal value. |
| ui2 | Two-byte unsigned integer. |
| ui4 | Four-byte unsigned integer. |
| i8 | Eight-byte integer. |
| ui8 | Eight-byte unsigned integer. |
| guid | GUID. |
| bytes | Bytes. |
| str | Null terminated ANSI character string with maximum length of 8000 characters. |
| wstr | Null terminated Unicode character string with maximum length of 8000 characters. |
| numeric | Numeric. |
| dbDate | A structure that consists of year, month, day. |
| dateTime | Date and time. |
| dbTime | A structure that consists of hour, minute, second. |
| dbTimeStamp | A structure that consists of year, month, day, hour, minute, and seconds, plus fractional parts. |
| image | Image. |
| text | Text. |
| nText | A Unicode character string with a maximum length of $2^{30} - 1$ characters. |
| dbTime2 | A dbtime type that also includes fractional seconds. |
| dbTimeStamp2 | A dbTimeStamp type that also includes fractional seconds. |
| dbTimeStampOffset | A dbTimeStamp type with a time zone offset. |

2.7.1.1.1.1.6.7 PipelineComponentPropertyAttributeGroup

The **PipelineComponentPropertyAttributeGroup** attribute group specifies the attributes that are used for all input and output columns that are specified by components.

The following is the XSD for the **PipelineComponentPropertyAttributeGroup** attribute group.

```
<xs:attributeGroup
  name="PipelineComponentPropertyAttributeGroup">
  <xs:attribute name="id" type="xs:int" form="unqualified"/>
  <xs:attribute name="dataType"
    type="DTS:PipelineComponentDataTypeEnum"
    form="unqualified"/>
  <xs:attribute name="state"
    type="DTS:PipelineComponentStateEnum"
    form="unqualified"/>
  <xs:attribute name="isArray" type="xs:boolean"
    form="unqualified"/>
  <xs:attribute name="description" type="xs:string"
    form="unqualified"/>
  <xs:attribute name="typeConverter" type="xs:string"
    form="unqualified"/>
  <xs:attribute name="UITypeEditor" type="xs:string"
    form="unqualified"/>
  <xs:attribute name="containsID" type="xs:boolean"
    form="unqualified"/>
  <xs:attribute name="expressionType"
    type="DTS:PipelineComponentExpressionTypeEnum"
    form="unqualified"/>
</xs:attributeGroup>
```

The following table specifies additional information for the attributes of the **PipelineComponentPropertyAttributeGroup** attribute group.

| Attribute | Description |
|----------------------|---|
| id | An integer value that specifies the identifier for this component property element. Other elements can refer to this component property element by using this id value. |
| name | A string value that specifies the name for this component property element. |
| dataType | An enumeration value that specifies the data type that is contained in the value for the property element. |
| state | An enumeration value that specifies the manner in which the property element value is serialized. |
| isArray | A Boolean value that specifies whether the value of the property element is an array. TRUE specifies that the value of the property element is an array. FALSE specifies that the value of the property element is not an array. |
| description | A string value that specifies the description for this component property element. |
| typeConverter | A string value that specifies the class name of a class that inherits from System.ComponentModel.TypeConverter. This class can be called to do type conversion from this component property type to another type. |
| UITypeEditor | A string value that specifies the class name of a class that derives from System.Drawing.Design.UITypeEditor and can be called by a user interface to edit a component property. |
| containsID | A Boolean value that specifies whether this property value is a reference to a column. TRUE specifies that this property value is a reference to a column. |

| Attribute | Description |
|-----------------------|--|
| | FALSE specifies that this property value is not a reference to a column. |
| expressionType | An enumeration value that specifies whether the value for the property can be specified through an expression. |

2.7.1.1.2 PipelinePathsType

The **PipelinePathsType** type specifies a collection of path objects for the Pipeline Task executable.

The following is the XSD for the **PipelinePathsType** type.

```
<xs:complexType name="PipelinePathsType">
  <xs:sequence>
    <xs:element name="path" type="DTS:PipelinePathType"
      form="unqualified" minOccurs="0" maxOccurs="unbounded"/>
  </xs:sequence>
</xs:complexType>
```

The following table specifies the elements of the **PipelinePathsType** type.

| Element | Type definition | Description |
|-------------|----------------------------------|--|
| path | PipelinePathType | A complex type that specifies a single path within a pipeline. |

2.7.1.1.2.1 PipelinePathType

The **PipelinePathType** type specifies a single path between two components of a Pipeline Task executable.

The following is the XSD for the **PipelinePathType** type.

```
<xs:complexType name="PipelinePathType">
  <xs:sequence/>
  <xs:attribute name="id" type="xs:int" form="unqualified"/>
  <xs:attribute name="name" type="xs:string" form="unqualified"/>
  <xs:attribute name="description" type="xs:string"
    form="unqualified"/>
  <xs:attribute name="startId" type="xs:int" form="unqualified"/>
  <xs:attribute name="endId" type="xs:int" form="unqualified"/>
</xs:complexType>
```

The following table specifies the attributes of the **PipelinePathType** type.

| Attribute | Description |
|--------------------|---|
| id | An integer value that specifies an identifier for this path element. Other elements can refer to this path element by using this id value. |
| name | A string value that specifies the name for this path element. |
| description | A string value that specifies the description for this path element. |
| startId | An integer value that specifies the identifier for a component that is where the path starts that this |

| Attribute | Description |
|--------------|---|
| | path element describes. |
| endId | An integer value that specifies the identifier for a component that is where the path ends that this path element describes. |

2.7.1.2 ActiveXScriptTaskData Element

The **ActiveXScriptTaskData** element is used to specify parameters, properties, and settings that are specific to the ActiveX Script Task. The **ActiveXScriptTaskData** element resides in the [ActiveXScriptTask](#) namespace. The [ExecutableObjectType](#) type refers to the **ActiveXScriptTaskData** element within an XSD **choice** element by using the XSD **ref** attribute, as in the following XSD fragment.

```
<xs:element ref="ActiveXScriptTask:ActiveXScriptTaskData" />
```

2.7.1.2.1 ActiveXScriptTask Namespace

The **ActiveXScriptTask** namespace specifies elements and types that are used by the ActiveX Script Task.

The following is the XSD declaration for the **ActiveXScriptTask** namespace.

```
xmlns:ActiveXScriptTask=
"www.microsoft.com/sqlserver/dts/tasks/activexscripttask"
```

2.7.1.2.1.1 ActiveXScriptTaskData Element

The **ActiveXScriptTaskData** element is used to specify parameters, properties, and settings that are specific to the ActiveX Script Task.

The following is the XSD for element declaration for the **ActiveXScriptTaskData** element in the [ActiveXScriptTask](#) namespace.

```
<xs:element name="ActiveXScriptTaskData"
type="ActiveXScriptTask:ActiveXScriptTaskDataType"/>
```

2.7.1.2.1.1.1 ActiveXScriptTaskDataType

The **ActiveXScriptTaskDataType** type holds parameters, properties, and settings for an ActiveX Script Task.

The following is the XSD for the **ActiveXScriptTaskDataType** type.

```
<xs:complexType name="ActiveXScriptTaskDataType">
  <xs:sequence/>
  <xs:attribute name="ScriptingLanguage"
type="ActiveXScriptTask:ScriptingLanguageEnum"/>
  <xs:attribute name="ScriptText" type="xs:string"/>
  <xs:attribute name="EntryMethod" type="xs:string"/>
</xs:complexType>
```

The **ActiveXScriptTaskDataType** type MUST NOT contain any elements or values.

The following table provides additional information for the attributes of the **ActiveXScriptTaskDataType** type.

| Attribute | Description |
|--------------------------|--|
| ScriptingLanguage | This enumeration value specifies the language that the script is written in. |
| ScriptText | This string value contains the software code for the script in the language that is indicated by the ScriptingLanguage attribute. |
| EntryMethod | This string value specifies the name of the method where the script is entered. |

2.7.1.2.1.1.1.1 ScriptingLanguageEnum

The **ScriptingLanguageEnum** type contains the enumeration values for the **ScriptingLanguage** attribute.

The following is the XSD for the **ScriptingLanguageEnum** type.

```
<xs:simpleType name="ScriptingLanguageEnum">
  <xs:restriction base="xs:string">
    <xs:enumeration value="VBScript"/>
    <xs:enumeration value="JScript.Compact"/>
    <xs:enumeration value="JScript"/>
  </xs:restriction>
</xs:simpleType>
```

The following table specifies the enumeration values for the **ScriptingLanguageEnum** type.

| Enumeration value | Description |
|------------------------|--|
| VBScript | Visual Basic Script language. For more information, see [MSDN-VBSLR] . |
| JScript.Compact | Java Script Compact EMCA 327. For more information, see [ECMA-327] . |
| Jscript | Java Script language. For more information, see [JavaSpec] . |

2.7.1.3 ASDdlDataObjectDataType

The **ASDdlDataObjectDataType** type is used to specify parameters, properties, and settings that are specific to the Analysis Services (AS) Execute Data Definition Language (DDL) Task.

The following is the XSD for the **ASDdlDataObjectDataType** type.

```
<xs:complexType name="ASDdlDataObjectDataType">
  <xs:sequence/>
  <xs:attribute name="ConnectionName" type="xs:string"
    form="unqualified"/>
  <xs:attribute name="SourceType" form="unqualified"
    type="DTS:SourceTypeEnum"/>
  <xs:attribute name="Source" type="xs:string"
    form="unqualified"/>
```

```
</xs:complexType>
```

The **ASDdlDataObjectDataType** type MUST NOT contain any elements or values.

The following table specifies the attributes of the **ASDdlDataObjectDataType** type.

| Attribute | Description |
|-----------------------|--|
| ConnectionName | The name of a connection manager that connects to an instance of Microsoft SQL Server Analysis Services or to a Analysis Services project. |
| SourceType | Specifies the source of the DDL statements. |
| Source | If the SourceType is "variable", this string contains the name of the variable that contains the DDL statements that the task executes. If the SourceType is "DirectInput", this string contains the text of the DDL statement as encoded XML. If the SourceType is "FileConnection", this string contains the value of the ObjectName property of a connection manager. |

2.7.1.4 ASProcessingDataObjectDataType

The **ASProcessingDataObjectDataType** complex type is used to specify parameters, properties, and settings that are specific to the AS Processing Task.

The following is the XSD for the **ASProcessingDataObjectDataType** complex type.

```
<xs:complexType name="ASProcessingDataObjectDataType">
  <xs:sequence/>
  <xs:attribute name="ConnectionName" type="xs:string"
    form="unqualified"/>
  <xs:attribute name="ProcessingCommands" type="xs:string"
    form="unqualified"/>
</xs:complexType>
```

The **ASProcessingDataObjectDataType** complex type MUST NOT contain any elements or values.

The following table provides additional information for the attributes of the **ASProcessingDataObjectDataType** complex type.

| Attribute | Description |
|---------------------------|---|
| ConnectionName | This string contains the name of a connection manager that is available in this package. The ConnectionName attribute is matched to the ObjectName property of the ConnectionManager type. |
| ProcessingCommands | This string contains a stream of encoded XML that contains the actual processing commands that are to be executed. |

2.7.1.5 BulkInsertTaskData Element

The **BulkInsertTaskData** element is used to specify parameters, properties, and settings that are specific to the Bulk Insert Task. The **BulkInsertTaskData** element resides in the [BulkInsertTask](#)

namespace. The **BulkInsertTaskData** type refers to the **BulkInsertTaskData** element within an XSD **choice** element, using the XSD **ref** attribute, as in the following XSD fragment.

The following is the XSD for the **BulkInsertTaskData** element.

```
<xs:element ref="BulkInsertTask:BulkInsertTaskData"/>
```

For more information about the **BulkInsertTaskData** element, see [ExecutableObjectDataType](#).

2.7.1.5.1 BulkInsertTask Namespace

The **BulkInsertTask** namespace specifies the elements and types that are used by the Bulk Insert Task.

The following is the XSD declaration for the **BulkInsertTask** namespace.

```
xmlns:BulkInsertTask=  
"www.microsoft.com/sqlserver/dts/tasks/bulkinserttask"
```

2.7.1.5.1.1 BulkInsertTaskData Element

The **BulkInsertTaskData** element is used to specify parameters, properties, and settings that are specific to the Bulk Insert Task.

The following is the XSD for the element declaration for the **BulkInsertTaskData** element in the [BulkInsertTask](#) namespace.

```
<xs:element name="BulkInsertTaskData"  
type="BulkInsertTask:BulkInsertTaskDataType"/>
```

2.7.1.5.1.1.1 BulkInsertTaskDataType

The **BulkInsertTaskDataType** type holds parameters, properties, and settings for a Bulk Insert Task.

The following is the XSD for the **BulkInsertTaskDataType** type.

```
<xs:complexType name="BulkInsertTaskDataType">  
  <xs:sequence/>  
  <xs:attribute name="BatchSize" type="BulkInsertTask:CodePageType"/>  
  <xs:attribute name="CheckConstraints">  
    <xs:simpleType>  
      <xs:restriction base="xs:string">  
        <xs:enumeration value="True"/>  
        <xs:enumeration value="False"/>  
      </xs:restriction>  
    </xs:simpleType>  
  </xs:attribute>  
  <xs:attribute name="CodePage" type="xs:string"/>  
  <xs:attribute name="SourceConnectionName" type="xs:string"/>  
  <xs:attribute name="DestinationConnectionName" type="xs:string"/>  
  <xs:attribute name="DataFileType"  
    type="BulkInsertTask:DataFileTypeEnum"/>  
  <xs:attribute name="DestinationTableName" type="xs:string"/>  
  <xs:attribute name="FirstRow" type="xs:int"/>  
  
  <xs:attribute name="LastRow" type="xs:int"/>  
  <xs:attribute name="UseFormatFile">  
    <xs:simpleType>
```

```

    <xs:restriction base="xs:string">
      <xs:enumeration value="True"/>
      <xs:enumeration value="False"/>
    </xs:restriction>
  </xs:simpleType>
</xs:attribute>
<xs:attribute name="FormatFile" type="xs:string"/>
<xs:attribute name="SortedData" type="xs:string"/>
<xs:attribute name="TableLock">
  <xs:simpleType>
    <xs:restriction base="xs:string">
      <xs:enumeration value="True"/>
      <xs:enumeration value="False"/>
    </xs:restriction>
  </xs:simpleType>
</xs:attribute>
<xs:attribute name="KeepIdentity">
  <xs:simpleType>
    <xs:restriction base="xs:string">
      <xs:enumeration value="True"/>
      <xs:enumeration value="False"/>
    </xs:restriction>
  </xs:simpleType>
</xs:attribute>
<xs:attribute name="KeepNulls">
  <xs:simpleType>
    <xs:restriction base="xs:string">
      <xs:enumeration value="True"/>
      <xs:enumeration value="False"/>
    </xs:restriction>
  </xs:simpleType>
</xs:attribute>
<xs:attribute name="FieldTerminator"
  type="BulkInsertTask:BulkInsertTaskTerminatorEnum"/>
<xs:attribute name="RowTerminator"
  type="BulkInsertTask:BulkInsertTaskTerminatorEnum"/>
<xs:attribute name="FireTriggers">
  <xs:simpleType>
    <xs:restriction base="xs:string">
      <xs:enumeration value="True"/>
      <xs:enumeration value="False"/>
    </xs:restriction>
  </xs:simpleType>
</xs:attribute>
<xs:attribute name="MaximumErrors" type="xs:int"/>
</xs:complexType>

```

The **BulkInsertTaskDataType** type MUST NOT contain elements or values.

The following table specifies additional information for the attributes of the **BulkInsertTaskDataType** type.

| Attribute | Description |
|-----------------------------|--|
| BatchSize | This integer specifies the number of rows in a batch. Each batch is processed as a single transaction. <55> |
| CheckConstraints | This enumeration value specifies whether constraints on the table are checked during the bulk insert operation. "True" specifies that constraints are checked. "False" specifies that constraints are not checked. |
| CodePage | This value specifies the code page of the data in the data file. |
| SourceConnectionName | This string specifies the name of the source connection file. |

| Attribute | Description |
|----------------------------------|--|
| DestinationConnectionName | This string specifies the name of the connection to the destination database. |
| DataFileType | This enumeration value specifies the type of text that is in the file. |
| DestinationTableName | This string specifies the name of the table in the destination database. |
| FirstRow | The row in the data file at which insertion begins. |
| LastRow | The row in the data file at which insertion ends. <56> |
| UseFormatFile | This enumeration value specifies whether a format file is used for the bulk insert operation. "True" specifies that a format file is used for the bulk insert operation. "False" specifies that a format file is not used for the bulk insert operation. |
| FormatFile | The string specifies the name of the format file. This string is used only when the UseFormatFile attribute is set to "True". |
| SortedData | This string specifies the columns on which to sort the data. |
| TableLock | This enumeration value specifies whether a table level lock is acquired for the bulk insert operation. "True" specifies that a table level lock is acquired for the bulk insert operation. "False" specifies that a table level lock is not acquired for the bulk insert operation. |
| KeepIdentity | This enumeration value specifies whether to keep data values from the data file for values for identity columns. "True" specifies that values present in the data file are kept for identity columns. "False" specifies that values present in the data file are not kept for identity columns. |
| KeepNulls | This enumeration value specifies whether null values in the input are retained. "True" specifies that null values in the input are retained. "False" specifies that a default value is used if a null value is encountered in the input. |
| FieldTerminator | This enumeration value specifies the character that terminates a field. |
| RowTerminator | This enumeration value specifies the character that terminates a row. |
| FireTriggers | This enumeration value specifies whether insert triggers that are specified for the table are fired during the bulk insert operation. "True" specifies that triggers are fired during the bulk insert operation. "False" specifies that triggers are not fired during the bulk insert operation. |
| MaximumErrors | This enumeration value specifies the maximum number of errors allowed. |

2.7.1.5.1.1.1.1 DataFileTypeEnum

The **DataFileTypeEnum** type contains the enumeration values for the **DataFileType** attribute.

The following is the XSD for the **DataFileTypeEnum** type.

```
<xs:simpleType name="DataFileTypeEnum">
```

```

<xs:restriction base="xs:string">
  <xs:enumeration value="DTSBulkInsert_DataFileType_Char"/>
  <xs:enumeration value="DTSBulkInsert_DataFileType_Native"/>
  <xs:enumeration value="DTSBulkInsert_DataFileType_WideChar"/>
  <xs:enumeration value="DTSBulkInsert_DataFileType_WideNative"/>
</xs:restriction>
</xs:simpleType>

```

The following table specifies the enumeration values for the **DataFileTypeEnum** type.

| Enumeration value | Description |
|--|---|
| DTSBulkInsert_DataFileType_Char | This enumeration value specifies that the data file contains character data. |
| DTSBulkInsert_DataFileType_Native | This enumeration value performs the bulk copy by using character types that are native to the database. <57> |
| DTSBulkInsert_DataFileType_WideChar | This enumeration value specifies that the data file contains Unicode [UNICODE] characters. |
| DTSBulkInsert_DataFileType_WideNative | This enumeration value functions the same as DTSBulkInsert_DataFileType_Native , except that columns of type char, varchar, and text are stored as Unicode. <58> |

2.7.1.5.1.1.1.2 CodePageType

The **CodePageType** type is used to specify the value of the code page of the data in the data file.

The following is the XSD for the **CodePageType** type.

```

<xs:simpleType name="CodePageType">
  <xs:union memberTypes="xs:int">
    <xs:simpleType>
      <xs:restriction base="xs:string">
        <xs:enumeration value="ACP"/>
        <xs:enumeration value="OEM"/>
        <xs:enumeration value="RAW"/>
      </xs:restriction>
    </xs:simpleType>
  </xs:union>
</xs:simpleType>

```

The **CodePageType** type is a union that allows an integer value or a value from a string enumeration. If the value is an integer, it represents the ANSI code page. If the value is a string enumeration value, it is one of the values in the following table.

| Enumeration value | Description |
|-------------------|---|
| ACP | Columns of char, varchar, or text data type SHOULD be converted from the ANSI code page (ISO 1252 [ISO/IEC8859-1]) to the server code page. <59> |
| OEM | Columns of char, varchar, or text data type SHOULD be converted from the system OEM code page to the server code page. <60> |
| RAW | No conversion from one code page to another occurs. |

2.7.1.5.1.1.3 BulkInsertTaskTerminatorEnum

The **BulkInsertTaskTerminatorEnum** type contains the enumeration values that can be specified for the demarcation of fields or records in the input data file.

The following is the XSD for the **BulkInsertTaskTerminatorEnum** type.

```
<xs:simpleType name="BulkInsertTaskTerminatorEnum">
  <xs:restriction base="xs:string">
    <xs:enumeration value="{CR}{LF}" />
    <xs:enumeration value="{CR}" />
    <xs:enumeration value="{LF}" />
    <xs:enumeration value="Semicolon {;}"/>
    <xs:enumeration value="Comma {,}" />
    <xs:enumeration value="Tab"/>
    <xs:enumeration value="Vertical Bar {|}" />
  </xs:restriction>
</xs:simpleType>
```

The following table specifies the enumeration values for the **BulkInsertTaskTerminatorEnum** type.

| Enumeration value | Description |
|-------------------|---|
| {CR}{LF} | Specifies that the terminator is a carriage return character followed by a line feed character. |
| {CR} | Specifies that the terminator is a carriage return character. |
| {LF} | Specifies that the terminator is a line feed character. |
| Semicolon {;} | Specifies that the terminator is a semicolon character. |
| Comma {,} | Specifies that the terminator is a comma character. |
| Tab | Specifies that the terminator is a tab character. |
| Vertical Bar { } | Specifies that the terminator is the vertical bar character. |

2.7.1.6 DMQueryTaskDataObjectDataType

The **DMQueryTaskDataObjectDataType** type is used to specify parameters, properties, and settings that are specific to the Data Mining Query Task.

The following is the XSD for the **DMQueryTaskDataObjectDataType** type.

```
<xs:complexType name="DMQueryTaskDataObjectDataType">
  <xs:sequence>
    <xs:element name="QueryString" form="unqualified"
      type="DTS:DMQueryTaskQueryStringContainerType"/>
    <xs:element name="QueryBuilderQueryString" form="unqualified"
      type="DTS:DMQueryTaskQueryStringContainerType"/>
    <xs:element name="QueryBuilderSpecification" form="unqualified"
      type="DTS:DMQueryBuilderSpecificationType"/>
  </xs:sequence>
  <xs:attribute name="InputConnection" type="xs:string"
    form="unqualified"/>
</xs:complexType>
```



```

<xs:attribute name="OutputConnection" type="xs:string"
  form="unqualified"/>
<xs:attribute name="ModelStructureName" type="xs:string"
  form="unqualified"/>
<xs:attribute name="ModelName" type="xs:string" form="unqualified"/>
<xs:attribute name="OverwriteOutputTable" form="unqualified">
  <xs:simpleType>
    <xs:restriction base="xs:string">
      <xs:enumeration value="True"/>
      <xs:enumeration value="False"/>
    </xs:restriction>
  </xs:simpleType>
</xs:attribute>
<xs:attribute name="OutputTableName" type="xs:string"
  form="unqualified"/>
</xs:complexType>

```

The following table specifies the elements of the **DMQueryTaskDataObjectDataType** type.

| Element | Type definition | Description |
|----------------------------------|---|---|
| QueryString | DMQueryTaskQueryStringContainerType | A string that specifies a data mining query. <61> |
| QueryBuilderQueryString | DMQueryTaskQueryStringContainerType | A string that specifies a data mining query that appears in the UI for data mining as the initial query string, which the user can then modify. |
| QueryBuilderSpecification | DMQueryBuilderSpecificationType | The complex content contained in the QueryBuilderSpecification element specifies information about the state of the Microsoft SQL Server Integration Services (SSIS) UI between sessions so that editing sessions can start from where a previous session finished. Further description of the contents of this element is outside the scope of this document. |

The following table specifies the attributes of the **DMQueryTaskDataObjectDataType** type.

| Attribute | Description |
|-----------------------------|--|
| InputConnection | This string value is the connection string to the data source for the data mining operation. |
| OutputConnection | This string value is the connection string to the database where the results of the data mining operation are written. |
| ModelStructureName | This string value contains the name of the data mining structure [MSDN-MSASDM] that is used for the data mining operation. |
| ModelName | This string value contains the name of the data mining model [MSDN-MMASDM] that is used for the data mining operation. |
| OverwriteOutputTable | This enumeration value specifies whether the table that is specified in the OutputTableName attribute can be overwritten. "True" specifies that data in the output table can be overwritten. "False" specifies that data in the output table cannot be overwritten. |
| OutputTableName | The name of the table in the output database where the results of the data mining |

| Attribute | Description |
|-----------|------------------------|
| | operation are written. |

2.7.1.6.1 DMQueryTaskQueryStringContainerType

The **DMQueryTaskQueryStringContainerType** type contains a string value that is the value of the specific element that is of the **DMQueryTaskQueryStringContainerType** type.

The following is the XSD for the **DMQueryTaskQueryStringContainerType** type.

```
<xs:complexType name="DMQueryTaskQueryStringContainerType">
  <xs:simpleContent>
    <xs:extension base="xs:string">
      <xs:attribute name="Sensitive" type="xs:boolean"
        form="unqualified"/>
      <xs:attribute name="Encrypted" type="xs:boolean"
        form="unqualified"/>
    </xs:extension>
  </xs:simpleContent>
</xs:complexType>
```

The **DMQueryTaskQueryStringContainerType** type MUST NOT contain any elements. The value of the **DMQueryTaskQueryStringContainerType** type is a string value, because the type is an extension of the string type. Attributes are added to the string type, as specified in this section.

The following table specifies additional information for the attributes of the **DMQueryTaskQueryStringContainerType** type.

| Attribute | Description |
|------------------|---|
| Sensitive | The attribute value contains an indicator for whether the string that is the value of the element is treated as sensitive. FALSE – Specifies that the element string value is not considered sensitive. TRUE – Specifies that the element string value is considered sensitive. |
| Encrypted | The attribute value contains an indicator for whether the element value is encrypted. FALSE – Specifies that the element value is not encrypted. TRUE – Specifies that the element value is encrypted. For more details about the encryption algorithm that is used if the value of the Encrypted attribute is TRUE, see Security . |

2.7.1.6.2 DMQueryBuilderSpecificationType

The **DMQueryBuilderSpecificationType** complex type contains unspecified XML content that is used for the Microsoft SQL Server Integration Services (SSIS) UI.

The following is the XSD for the **DMQueryBuilderSpecificationType** complex type.

```
<xs:complexType name="DMQueryBuilderSpecificationType">
  <xs:sequence>
    <xs:any minOccurs="0" maxOccurs="unbounded"
      namespace="##any" processContents="lax"/>
  </xs:sequence>
```

```

<xs:attribute name="Sensitive" type="xs:boolean"
              form="unqualified"/>
<xs:attribute name="Encrypted" type="xs:boolean"
              form="unqualified"/>
</xs:complexType>

```

The following table specifies additional information for the attributes of the **DMQueryBuilderSpecificationType** complex type.

| Attribute | Description |
|------------------|---|
| Sensitive | The attribute value contains an indicator for whether the element content is treated as sensitive. FALSE – Specifies that the element content is not considered sensitive. TRUE – Specifies that the element content is considered sensitive. |
| Encrypted | The attribute value contains an indicator for whether the element content is encrypted. FALSE – Specifies that the element content is not encrypted. TRUE – Specifies that the element content is encrypted. |

2.7.1.7 DataProfilingTaskDataObjectDataType

The **DataProfilingTaskDataObjectDataType** complex type is used to specify parameters, properties, and settings that are specific to the Data Profiling Task.

The following is the XSD for the **DataProfilingTaskDataObjectDataType** complex type.

```

<xs:complexType name="DataProfilingTaskDataObjectDataType">
  <xs:sequence>
    <xs:element name="ProfileInput" type="xs:string"
              form="unqualified"/>
  </xs:sequence>
  <xs:attribute name="DestinationType" form="unqualified"
              type="DTS:DestinationTypeEnum" />
  <xs:attribute name="Destination" type="xs:string"
              form="unqualified"/>
  <xs:attribute name="OverwriteDestination" form="unqualified">
    <xs:simpleType>
      <xs:restriction base="xs:string">
        <xs:enumeration value="True"/>
        <xs:enumeration value="False"/>
      </xs:restriction>
    </xs:simpleType>
  </xs:attribute>
</xs:complexType>

```

The following table specifies the elements of the **DataProfilingTaskDataObjectDataType** complex type.

| Element | Type definition | Description |
|---------------------|--|---|
| ProfileInput | String. The content of the string is further defined in Data Profiling ProfileInput String Format Definition . | A string value that contains encoded XML that specifies parameters, properties, and settings for the Data Profiling Task. |

The following table specifies the attributes of the **DataProfilingTaskDataObjectDataType** complex type.

| Attribute | Description |
|-----------------------------|---|
| DestinationType | This enumeration value specifies whether to save the output to a file connection or to a variable. |
| Destination | This string specifies the name of the file connection or the name of the variable in which to save the Data Profiling Task output. |
| OverwriteDestination | This enumeration value specifies whether the output from this task can overwrite any previously existing content at the output destination. "True" specifies that previously existing content at the destination for output can be overwritten. "False" specifies that previously existing content at the destination for output cannot be overwritten. |

2.7.1.7.1 Data Profiling ProfileInput String Format Definition

The **ProfileInput** element appears within the Microsoft SQL Server Integration Services (SSIS) package stream as a string value. This string value is shown in the XSD in [DataProfilingTaskDataObjectDataType](#) where the **ProfileInput** element is defined as type **xs:string**.

However, the content of that string value is encoded XML. This section specifies the XML in the string value by using XSD. Despite the use of XSD in these sections, this value is a string at the Integration Services package level.

2.7.1.7.1.1 DataProfile Root Element of the ProfileInput String

The **DataProfile** element is the root element of the XML that is encoded as a string that is contained in the **ProfileInput**.

The following is the XSD of the **DataProfile** element declaration.

```
<xs:element name="DataProfile">
  <xs:complexType>
    <xs:sequence>
      <xs:element name="DataSources" type="DataSourcesType" />
      <!-- Input -->
      <xs:element name="DataProfileInput" type="DataProfileInputType"
        minOccurs="0" maxOccurs="1" />
      <!-- Output -->
      <xs:element name="DataProfileOutput" type="DataProfileOutputType"
        minOccurs="0" maxOccurs="1" />
    </xs:sequence>
  </xs:complexType>
</xs:element>
```

The following table specifies additional information about the elements and types for the **DataProfile** root element.

| Element | Type definition | Description |
|--------------------------|---------------------------------------|--|
| DataSources | DataSourcesType | This complex type specifies the data sources that are referenced by the Data Profiling Task. |
| DataProfileInput | DataProfileInputType | This complex type specifies what to profile and how to profile it. |
| DataProfileOutput | DataProfileOutputType | This complex type specifies the profile output. |

2.7.1.7.1.1.1 DataSourcesType

The **DataSourcesType** type MAY contain references to data sources. [<62>](#)

The following is the XSD of the **DataSourcesType** type.

```
<xs:complexType name="DataSourcesType">
  <xs:sequence>
</xs:sequence>
</xs:complexType>
```

2.7.1.7.1.1.2 DataProfileInputType

The **DataProfileInputType** type is used to specify parameters, properties, and settings that are specific to the Data Profiling Task.

The following is the XSD of the **DataProfileInputType** type.

```
<xs:complexType name="DataProfileInputType">
  <xs:sequence>
    <xs:element name="ProfileMode" type="ProfileModeType"
      minOccurs="1" maxOccurs="1" />
    <xs:element name="Timeout" type="xs:int" minOccurs="0"
      maxOccurs="1" default="0" />
    <xs:element name="Requests" minOccurs="1" maxOccurs="1">
      <xs:complexType>
        <xs:sequence>
          <xs:element ref="ProfileRequest" minOccurs="0"
            maxOccurs="unbounded" />
        </xs:sequence>
      </xs:complexType>
    </xs:element>
  </xs:sequence>
</xs:complexType>
```

The following table specifies additional information about the elements and types for the **DataProfileInputType** type.

| Element | Type definition | Description |
|--------------------|--|--|
| ProfileMode | ProfileModeType | An enumeration value that specifies in which mode the profile is run. <63> |
| Timeout | xs:integer | An integer value that specifies the timeout interval for the Data Profiling Task in seconds. |
| Requests | ProfileRequest Element | A complex type that contains all of the profile requests to be run by the Data Profiling Task. |

2.7.1.7.1.1.2.1 ProfileModeType

The **ProfileModeType** type specifies the enumeration values for the **ProfileMode** element.

The following is the XSD of the **ProfileModeType** type.

```

<xs:simpleType name="ProfileModeType">
  <xs:restriction base="xs:string">
    <xs:enumeration value="Fast" />
    <xs:enumeration value="Exact" />
  </xs:restriction>
</xs:simpleType>

```

The following table specifies the enumeration values for the **ProfileModeType** type.

| Enumeration value | Description |
|-------------------|--|
| Fast | A profile that is computed in fast mode and does not always return an exact profile. |
| Exact | A profile that is computed and always returns an exact profile. |

2.7.1.7.1.1.2.2 ProfileRequest Element

The **ProfileRequest** element is an abstract element that is a placeholder for elements that contain a specific data profile request. Elements that can be substituted for this placeholder have the **substitutionGroup** attribute of the element set to the value "ProfileRequest".

The following is the XSD of the **ProfileRequest** element.

```

<xs:element name="ProfileRequest" type="ProfileRequestType"
  abstract="true" />

```

2.7.1.7.1.1.2.2.1 ProfileRequestType

The **ProfileRequestType** abstract type is used to hold a profile request. The **ProfileRequestType** abstract type specifies an attribute that is common to many requests. The content of elements of type **ProfileRequestType** is specified for each specific element that can be substituted for the element of this type that appears in an XML instance document.

The following is the XSD of the **ProfileRequestType** abstract type.

```

<xs:complexType name="ProfileRequestType" abstract="true">
  <xs:attribute name="ID" type="xs:string" use="required" />
</xs:complexType>

```

The **ProfileRequestType** abstract type can contain elements, depending on the type of the element that is substituted.

The following table specifies additional information for the attributes of the **ProfileRequestType** abstract type.

| Attribute | Description |
|-----------|--|
| ID | A string value that specifies an identification string that is used to refer to the data profile request elsewhere in the package. |

2.7.1.7.1.1.2.2.2 Elements That Can Be Substituted for the ProfileRequest Element

The following elements have the XSD **substitutionGroup** attribute set to "ProfileRequest" in their XSD definition. Thus, they can be substituted for the **ProfileRequest** element. More details about the following elements and their associated complex types are provided later in this section.

- ColumnStatisticsProfileRequest
- ColumnLengthDistributionProfileRequest
- ColumnValueDistributionProfileRequest
- ColumnNullRatioProfileRequest
- ColumnPatternProfileRequest
- CandidateKeyProfileRequest
- FunctionalDependencyProfileRequest
- InclusionProfileRequest

2.7.1.7.1.1.2.2.2.1 ColumnStatisticsProfileRequest Element

The **ColumnStatisticsProfileRequest** element is used to specify parameters, properties, and settings that are used to request a column statistics profile. A column statistics profile reports statistics about numeric or date/time columns of a database.

The **ColumnStatisticsProfileRequest** element has the XSD **substitutionGroup** attribute set to the value "ProfileRequest"; therefore, it is one of the elements that can be substituted for the [ProfileRequest](#) element.

The following is the XSD of the **ColumnStatisticsProfileRequest** element declaration.

```
<xs:element name="ColumnStatisticsProfileRequest"
  type="ColumnStatisticsProfileRequestType"
  substitutionGroup="ProfileRequest" />
```

2.7.1.7.1.1.2.2.2.1.1 ColumnStatisticsProfileRequestType

The **ColumnStatisticsProfileRequestType** complex type is the type of the ColumnStatisticsProfileRequest element.

The following is the XSD of the **ColumnStatisticsProfileRequestType** complex type.

```
<xs:complexType name="ColumnStatisticsProfileRequestType"
  final="#all">
  <xs:complexContent>
    <xs:extension base="ColumnProfileRequestType">
    </xs:extension>
  </xs:complexContent>
</xs:complexType>
```

All of the elements and attributes of the **ColumnStatisticsProfileRequestType** type are contained in the definition of its base type, the **ColumnProfileRequestType** complex type. The **ColumnStatisticsProfileRequestType** type MUST NOT contain additions or extensions that are not specified in the **ColumnProfileRequestType** complex type.

2.7.1.7.1.1.2.2.2.2 ColumnLengthDistributionProfileRequest Element

The **ColumnLengthDistributionProfileRequest** element is used to specify parameters, properties, and settings that are used to request column length distribution profiles. A column length distribution

profile, an option of the Data Profiling Task, reports all the distinct lengths of string values in the selected column and the percentage of rows in the table that each length represents.

The **ColumnLengthDistributionProfileRequest** element has the XSD **substitutionGroup** attribute set to the value "ProfileRequest"; therefore, it is one of the elements that can be substituted for the ProfileRequest element.

The following is the XSD of the **ColumnLengthDistributionProfileRequest** element declaration.

```
<xs:element name="ColumnLengthDistributionProfileRequest"
  type="ColumnLengthDistributionProfileRequestType"
  substitutionGroup="ProfileRequest" />
```

2.7.1.7.1.1.2.2.2.1 **ColumnLengthDistributionProfileRequestType**

The **ColumnLengthDistributionProfileRequestType** complex type is the type of the ColumnLengthDistributionProfileRequest element.

The following is the XSD of the **ColumnLengthDistributionProfileRequestType** complex type.

```
<xs:complexType name="ColumnLengthDistributionProfileRequestType"
  final="#all">
  <xs:complexContent>
    <xs:extension base="ColumnProfileRequestType">
      <xs:sequence>
        <xs:element name="IgnoreLeadingSpace" type="xs:boolean"
          minOccurs="0" maxOccurs="1" default="false" />
        <xs:element name="IgnoreTrailingSpace" type="xs:boolean"
          minOccurs="0" maxOccurs="1" default="true" />
      </xs:sequence>
    </xs:extension>
  </xs:complexContent>
</xs:complexType>
```

The **ColumnLengthDistributionProfileRequestType** complex type is an extension of the **ColumnProfileRequestType** complex type. The following table specifies additional information about the elements in the **ColumnLengthDistributionProfileRequestType** complex type.

| Element | Type definition | Description |
|----------------------------|-----------------|---|
| IgnoreLeadingSpace | xs:Boolean | A Boolean value that specifies whether to ignore leading spaces when comparing string values. TRUE indicates that leading spaces MUST be ignored when comparing string values. FALSE indicates that leading spaces MUST NOT be ignored when comparing string values. |
| IgnoreTrailingSpace | xs:Boolean | A Boolean value that specifies whether to ignore trailing spaces when comparing string values. TRUE indicates that trailing spaces MUST be ignored when comparing string values. FALSE indicates that trailing spaces MUST NOT be ignored when comparing string values. |

2.7.1.7.1.1.2.2.2.3 **ColumnValueDistributionProfileRequest Element**

The **ColumnValueDistributionProfileRequest** element is used to specify parameters, properties, and settings that are used to request column value distribution profiles. A column value distribution

profile, an option of the Data Profiling Task, reports all the distinct values in the selected column and the percentage of rows in the table that each value represents.

The **ColumnValueDistributionProfileRequest** element has the XSD **substitutionGroup** attribute set to the value "ProfileRequest"; therefore, it is one of the elements that can be substituted for the ProfileRequest element.

The following is the XSD of the **ColumnValueDistributionProfileRequest** element declaration.

```
<xs:element name="ColumnValueDistributionProfileRequest"
  type="ColumnValueDistributionProfileRequestType"
  substitutionGroup="ProfileRequest" />
```

2.7.1.7.1.1.2.2.3.1 **ColumnValueDistributionProfileRequestType**

The **ColumnValueDistributionProfileRequestType** complex type is the type of the ColumnValueDistributionProfileRequest element.

The following is the XSD of the **ColumnValueDistributionProfileRequestType** complex type.

```
<xs:complexType name="ColumnValueDistributionProfileRequestType"
  final="#all">
  <xs:complexContent>
    <xs:extension base="ColumnProfileRequestType">
      <xs:sequence>
        <xs:element name="Option" type="ValueDistributionOptions"
          minOccurs = "1" />
        <xs:element name="FrequentValueThreshold" type="xs:double"
          minOccurs="0" maxOccurs="1" />
      </xs:sequence>
    </xs:extension>
  </xs:complexContent>
</xs:complexType>
```

The **ColumnValueDistributionProfileRequestType** complex type is an extension of the **ColumnProfileRequestType** complex type. The following table specifies additional information about the elements in the **ColumnValueDistributionProfileRequestType** complex type.

| Element | Type definition | Description |
|-------------------------------|--------------------------|--|
| Option | ValueDistributionOptions | This enumeration value specifies whether to include all values in the distribution computation. |
| FrequentValueThreshold | xs:double | This double value between 0 and 1, inclusive, specifies the threshold at which to include values in the distribution computation. This value is ignored if the value of the Option attribute is not equal to "FrequentValueThreshold". <64> |

2.7.1.7.1.1.2.2.3.1.1 **ValueDistributionOptions**

The **ValueDistributionOptions** type specifies the enumeration values for the **Options** element.

The following is the XSD of the **ValueDistributionOptions** type.

```
<xs:simpleType name="ValueDistributionOptions">
  <xs:restriction base="xs:string">
    <xs:enumeration value="AllValues" />
    <xs:enumeration value="FrequentValues" />
  </xs:restriction>
</xs:simpleType>
```

```

    </xs:restriction>
  </xs:simpleType>

```

The following table specifies the enumeration values for the **ValueDistributionOptions** type.

| Enumeration value | Description |
|-----------------------|--|
| AllValues | The distribution is computed for all values. |
| FrequentValues | The distribution is computed only for values whose frequency exceeds the minimum value that is specified in the FrequentValueThreshold element. |

2.7.1.7.1.1.2.2.4 **ColumnNullRatioProfileRequest Element**

The **ColumnNullRatioProfileRequest** element is used to specify parameters, properties, and settings that are used to request column null ratio distribution profiles. A column null ratio distribution profile, an option of the Data Profiling Task, reports the percentage of null values in the selected column.

The **ColumnNullRatioProfileRequest** element has the XSD **substitution** attribute set to the value "ProfileRequest"; therefore, it is one of the elements that can be substituted for the ProfileRequest element.

The following is the XSD of the **ColumnNullRatioProfileRequest** element declaration.

```

<xs:element name="ColumnNullRatioProfileRequest"
  type="ColumnNullRatioProfileRequestType"
  substitutionGroup="ProfileRequest" />

```

2.7.1.7.1.1.2.2.4.1 **ColumnNullRatioProfileRequestType**

The **ColumnNullRatioProfileRequestType** complex type is the type of the **ColumnNullRatioProfileRequest** element.

The following is the XSD of the **ColumnNullRatioProfileRequestType** complex type.

```

<xs:complexType name="ColumnNullRatioProfileRequestType"
  final="#all">
  <xs:complexContent>
    <xs:extension base="ColumnProfileRequestType">
    </xs:extension>
  </xs:complexContent>
</xs:complexType>

```

All of the elements and attributes of the **ColumnNullRatioProfileRequestType** complex type are contained in the definition of its base type, the **ColumnProfileRequestType** complex type. The **ColumnNullRatioProfileRequestType** type MUST NOT contain additions or extensions that are not specified in the **ColumnProfileRequestType** complex type.

2.7.1.7.1.1.2.2.5 **ColumnPatternProfileRequest Element**

The **ColumnPatternProfileRequest** element is used to specify parameters, properties, and settings that are used to request column pattern profiles. A column pattern profile, an option of the Data Profiling Task, reports a set of regular expressions that cover the specified percentage of values in a string column.

The **ColumnPatternProfileRequest** element has the XSD **substitutionGroup** attribute set to the value "ProfileRequest"; therefore, it is one of the elements that can be substituted for the ProfileRequest element.

The following is the XSD of the **InclusionProfileRequest** element declaration.

```
<xs:element name="ColumnPatternProfileRequest"
  type="ColumnPatternProfileRequestType"
  substitutionGroup="ProfileRequest" />
```

2.7.1.7.1.1.2.2.5.1 ColumnPatternProfileRequestType

The **ColumnPatternProfileRequestType** complex type is the type of the **ColumnPatternProfileRequest** element.

The following is the XSD of the **ColumnPatternProfileRequestType** complex type.

```
<xs:complexType name=" ColumnPatternProfileRequestType " final="#all">
  <xs:complexContent>
    <xs:extension base="ColumnProfileRequestType">
      <xs:sequence>
        <xs:element name="MaxNumberOfPatterns" type="xs:int"
          minOccurs="0"/>
        <xs:element name="PercentageDataCoverageDesired"
          type="xs:int" minOccurs="0"/>
        <xs:element name="CaseSensitive" type="xs:boolean"
          minOccurs="0"/>
        <xs:element name="Delimiters" type="xs:string"
          minOccurs="0"/>
        <xs:element name="Symbols" type="xs:string"
          minOccurs="0"/>
        <xs:element name="TagDataSourceId" type="xs:string"
          minOccurs="0"/>
        <xs:element name="TagTableName" type="TableQNameType"
          minOccurs="0"/>
      </xs:sequence>
    </xs:extension>
  </xs:complexContent>
</xs:complexType>
```

The **ColumnPatternProfileRequestType** complex type is an extension of the base type, the **ColumnProfileRequestType** complex type. The following table specifies additional information about the elements in the **ColumnPatternProfileRequestType** complex type.

| Element | Type definition | Description |
|--------------------------------------|-----------------|--|
| MaxNumberOfPatterns | xs:int | An integer value that specifies the maximum number of patterns that are returned by the column pattern profile task. <65> |
| PercentageDataCoverageDesired | xs:int | An integer value that specifies the percentage of the data that is described by the patterns that are returned by the column pattern profile task. <66> |
| CaseSensitive | xs:Boolean | A Boolean value that specifies whether to consider strings as case-sensitive. TRUE specifies that case MUST be considered in determining the pattern. FALSE specifies that case MUST be ignored in determining the pattern. <67> |

| Element | Type definition | Description |
|------------------------|-----------------|--|
| Delimiters | xs:string | A string value that specifies the characters that are treated as the equivalent of spaces between words when tokenizing text. <68> |
| Symbols | xs:string | A string value that specifies the symbols that are retained as part of patterns. <69> |
| TagDataSourceId | xs:string | A string value that contains an identifier for the tag table . |
| TagTableName | TableQNameType | A complex type that specifies information to reference the table that is used as the tag table. |

2.7.1.7.1.1.2.2.2.6 **CandidateKeyProfileRequest Element**

The **CandidateKeyProfileRequest** element is used to specify parameters, properties, and settings that are used to request candidate key profiles. A candidate key profile, an option of the Data Profiling Task, reports whether a column or set of columns is a key or an approximate key for a specified table.

The **CandidateKeyProfileRequest** element has the XSD **substitutionGroup** attribute set to the value "ProfileRequest"; therefore, the **CandidateKeyProfileRequest** element is one of the elements that can be substituted for the ProfileRequest element.

The following is the XSD of the **CandidateKeyProfileRequest** element declaration.

```
<xs:element name="CandidateKeyProfileRequest"
  type="CandidateKeyProfileRequestType"
  substitutionGroup="ProfileRequest" />
```

2.7.1.7.1.1.2.2.2.6.1 **CandidateKeyProfileRequestType**

The **CandidateKeyProfileRequestType** complex type is the type of the **CandidateKeyProfileRequest** element.

The following is the XSD of the **CandidateKeyProfileRequestType** complex type.

```
<xs:complexType name="CandidateKeyProfileRequestType"
  final="#all">
  <xs:complexContent>
    <xs:extension base="TableProfileRequestType">
      <xs:sequence>
        <xs:element name="KeyColumns"
          type="ColumnParameterCollectionType"
          minOccurs="1" maxOccurs="1" />
        <xs:element name="ThresholdSetting"
          type="StrengthThresholdSettingType"
          minOccurs="1" maxOccurs="1" />
        <xs:element name="KeyStrengthThreshold" type="xs:double"
          minOccurs="0" maxOccurs="1" />
        <xs:element name="VerifyOutputInFastMode" type="xs:boolean"
          default="true" minOccurs="0" maxOccurs="1" />
        <xs:element name="MaxNumberOfViolations" type="xs:int"
          minOccurs="0" maxOccurs="1" default="-1" />
      </xs:sequence>
    </xs:extension>
  </xs:complexContent>
</xs:complexType>
```

The **CandidateKeyProfileRequestType** complex type is an extension of the **TableProfileRequestType** complex type. The following table specifies additional information about the elements in the **CandidateKeyProfileRequestType** complex type.

| Element | Type definition | Description |
|-------------------------------|-------------------------------|--|
| KeyColumns | ColumnParameterCollectionType | A complex type that specifies the column or columns to be profiled as key candidates. |
| ThresholdSetting | StrengthThresholdSettingType | An enumeration value that specifies what type of threshold to use in identifying a key candidate. |
| KeyStrengthThreshold | xs:double | A double value that specifies the minimum strength that is required to report a candidate key. This value is used only if the ThresholdSetting element is set to the value "Specified". <70> |
| VerifyOutputInFastMode | xs:Boolean | A Boolean value that specifies whether the output verification step is performed in fast mode. TRUE specifies that output verification is performed in fast mode. FALSE specifies that output verification is not performed in fast mode. <71> |
| MaxNumberOfViolations | xs:int | An integer value that specifies the maximum number of candidate key violations to report in the output. This option is disabled when the KeyStrengthThreshold element is set to the value "Exact". <72> |

2.7.1.7.1.1.2.2.2.7 **FunctionalDependencyProfileRequest Element**

The **FunctionalDependencyProfileRequest** element is used to specify parameters, properties, and settings that are used to request functional dependency profiles. A functional dependency profile, an option of the Data Profiling Task, reports the extent to which the values in one column (the dependent column) depend on the values in another column or set of columns (the determinant column).

The **FunctionalDependencyProfileRequest** element has the XSD **substitutionGroup** attribute set to the value "ProfileRequest"; therefore, it is one of the elements that can be substituted for the ProfileRequest element.

The following is the XSD of the **FunctionalDependencyProfileRequest** element declaration.

```
<xs:element name="FunctionalDependencyProfileRequest"
  type="FunctionalDependencyProfileRequestType"
  substitutionGroup="ProfileRequest" />
```

2.7.1.7.1.1.2.2.2.7.1 **FunctionalDependencyProfileRequestType**

The **FunctionalDependencyProfileRequestType** complex type is the type of the **FunctionalDependencyProfileRequest** element.

The following is the XSD of the **FunctionalDependencyProfileRequestType** complex type.

```
<xs:complexType name="FunctionalDependencyProfileRequestType"
  final="#all">
  <xs:complexContent>
```

```

<xs:extension base="TableProfileRequestType">
  <xs:sequence>
    <xs:element name="DeterminantColumns"
      type="ColumnParameterCollectionType"
      minOccurs="1" maxOccurs="1" />
    <xs:element name="DependentColumn" type="ColumnParameterType"
      minOccurs="1" maxOccurs="1" />
    <xs:element name="ThresholdSetting"
      type="StrengthThresholdSettingType"
      minOccurs="1" maxOccurs="1" />
    <xs:element name="FDStrengthThreshold" type="xs:double"
      minOccurs="0" maxOccurs="1" />
    <xs:element name="VerifyOutputInFastMode" type="xs:boolean"
      default="true" minOccurs="0" maxOccurs="1" />
    <xs:element name="MaxNumberOfViolations" default="-1"
      type="xs:int" minOccurs="0" maxOccurs="1" />
  </xs:sequence>
</xs:extension>
</xs:complexContent>
</xs:complexType>

```

The **FunctionalDependencyProfileRequestType** complex type is an extension of the **TableProfileRequestType** complex type. The following table specifies additional information about the elements in the **FunctionalDependencyProfileRequestType** complex type.

| Element | Type definition | Description |
|-------------------------------|-------------------------------|--|
| DeterminantColumns | ColumnParameterCollectionType | A complex type that specifies a collection of determinant columns, which are the columns that are assessed for their ability to determine the dependent columns. |
| DependentColumn | ColumnParameterType | A complex type that specifies the column for which the dependency on the determinant columns is computed. |
| ThresholdSetting | StrengthThresholdSettingType | An enumeration value that specifies what type of threshold to use to identify a key candidate. |
| FDStrengthThreshold | xs:double | A double value that specifies the minimum functional dependency threshold that is required to consider a dependency as existing. This value is used only if the value of the ThresholdSetting element is set to "Specified". <73> |
| VerifyOutputInFastMode | xs:boolean | A Boolean value that specifies whether the output verification step is performed in fast mode. TRUE specifies that output verification is performed in fast mode. FALSE specifies that output verification is not performed in fast mode. <74> |
| MaxNumberOfViolations | xs:int | An integer value that specifies the maximum number of candidate key violations to report in the output. This option is disabled when the KeyStrengthThreshold element is set to the value "Exact". <75> |

2.7.1.7.1.1.2.2.2.8 **InclusionProfileRequest Element**

The **InclusionProfileRequest** element is used to specify parameters, properties, and settings that are used to request value inclusion profiles. A value inclusion profile, an option of the Data Profiling Task, computes the overlap in the values between two columns or sets of columns. Thus, the value inclusion profile can determine whether a column or set of columns is appropriate to serve as a foreign key between the selected tables.

The **InclusionProfileRequest** element has the XSD **substitutionGroup** attribute set to the value "ProfileRequest"; therefore, the **InclusionProfileRequest** element is one of the elements that can be substituted for the ProfileRequest element.

The following is the XSD of the **InclusionProfileRequest** element declaration.

```
<xs:element name="InclusionProfileRequest"
            type="InclusionProfileRequestType"
            substitutionGroup="ProfileRequest" />
```

2.7.1.7.1.1.2.2.8.1 **InclusionProfileRequestType**

The **InclusionProfileRequestType** complex type is the type of the **InclusionProfileRequest** element.

The following is the XSD of the **InclusionProfileRequestType** complex type.

```
<xs:complexType name="InclusionProfileRequestType" final="#all">
  <xs:complexContent>
    <xs:extension base="ProfileRequestType">
      <xs:sequence>
        <xs:element name="SubsetDataSourceID" type="xs:string"
                    minOccurs="0" maxOccurs="1" />
        <xs:element name="SubsetTable" type="TableQNameType"
                    minOccurs="1" maxOccurs="1" />
        <xs:element name="SubsetColumns"
                    type="ColumnParameterCollectionType"
                    minOccurs="1" maxOccurs="1" />
        <xs:element name="SupersetDataSourceID" type="xs:string"
                    minOccurs="0" maxOccurs="1" />
        <xs:element name="SupersetTable" type="TableQNameType"
                    minOccurs="1" maxOccurs="1" />
        <xs:element name="SupersetColumns"
                    type="ColumnParameterCollectionType"
                    minOccurs="1" maxOccurs="1" />
        <xs:element name="InclusionThresholdSetting"
                    type="StrengthThresholdSettingType"
                    minOccurs="1" maxOccurs="1" />
        <xs:element name="InclusionStrengthThreshold" type="xs:double"
                    minOccurs="0" maxOccurs="1" />
        <xs:element name="SupersetColumnsKeyThresholdSetting"
                    type="StrengthThresholdSettingType"
                    minOccurs="1" maxOccurs="1" />
        <xs:element name="SupersetColumnsKeyThreshold" type="xs:double"
                    minOccurs="0" maxOccurs="1" />
        <xs:element name="VerifyOutputInFastMode" type="xs:boolean"
                    default="true" minOccurs="0" maxOccurs="1" />
        <xs:element name="MaxNumberOfViolations" default="-1"
                    type="xs:int" minOccurs="0" maxOccurs="1" />
      </xs:sequence>
    </xs:extension>
  </xs:complexContent>
</xs:complexType>
```

The **InclusionProfileRequestType** complex type is an extension of the base type, the [ProfileRequestType](#) abstract type. The following table specifies additional information about the elements in the **InclusionProfileRequestType** complex type.

| Element | Type definition | Description |
|---|-------------------------------|---|
| SubsetDataSourceID | xs:string | A string value that contains an identifier for the subset data source. |
| SubsetTable | TableQNameType | A complex type that specifies information to reference the table that is used as the subset table. |
| SubsetColumns | ColumnParameterCollectionType | A complex type that specifies the columns that constitute the subset for which determination of the value inclusion profile is computed. |
| SupersetDataSourceID | xs:string | A string value that contains an identifier for the superset data source. <76> |
| SupersetTable | TableQNameType | A complex type that specifies information to reference the table that is used as the superset table. |
| SupersetColumns | ColumnParameterCollectionType | A complex type that specifies the columns that constitute the superset for which determination of the value inclusion profile is computed. |
| InclusionThresholdSetting | StrengthThresholdSettingType | An enumeration value that specifies what type of threshold to use in the value inclusion profile. |
| InclusionStrengthThreshold | xs:double | A double value that specifies the minimum inclusion strength that is required to report the inclusion strength. This value is used only if the value of the InclusionThresholdSetting element is set to "Specified". <77> |
| SupersetColumnsKeyThresholdSetting | StrengthThresholdSettingType | An enumeration value that specifies what type of threshold to use in the value inclusion profile for a key. |
| SupersetColumnsKeyThreshold | xs:double | A double value that specifies the minimum inclusion strength that is required to report the inclusion strength of the suitability of the column as a key. This value is used only if the value of the SupersetColumnsKeyThresholdSetting element is set to "Specified". <78> |
| VerifyOutputInFastMode | xs:boolean | A Boolean value that specifies whether the output verification step is performed in fast mode. TRUE specifies that output verification is performed in fast mode. FALSE specifies that output verification is not performed in fast mode. <79> |

| Element | Type definition | Description |
|------------------------------|-----------------|--|
| MaxNumberOfViolations | xs:int | An integer value that specifies the maximum number of violations to report in the output. This option is disabled when the value of the InclusionThresholdSetting element is set to "Exact". <80> |

2.7.1.7.1.1.2.2.3 Abstract Base Types Used by Data Profiling Task

The following abstract types are used as a base for extension or restriction for instance types that are used by the Data Profiling Task.

- ColumnProfileRequestType
- TableProfileRequestType

2.7.1.7.1.1.2.2.3.1 ColumnProfileRequestType

The **ColumnProfileRequestType** complex type is the base type from which many types that request a profile of a column are extended.

The following is the XSD of the **ColumnProfileRequestType** complex type.

```
<xs:complexType name="ColumnProfileRequestType" abstract="true">
  <xs:complexContent>
    <xs:extension base="TableProfileRequestType">
      <xs:sequence>
        <xs:element name="Column" type="ColumnParameterType"
          minOccurs="1" maxOccurs="1" />
      </xs:sequence>
    </xs:extension>
  </xs:complexContent>
</xs:complexType>
```

The following table specifies additional information about the elements in the **ColumnProfileRequestType** complex type.

| Element | Type definition | Description |
|---------------|---------------------|--|
| Column | ColumnParameterType | A complex type that specifies information that is sufficient to identify a column at a data source for which a profile is being requested. |

2.7.1.7.1.1.2.2.3.1 TableProfileRequestType

The **TableProfileRequestType** complex type is the base type from which many types that request a profile of a table or of table elements are extended.

The following is the XSD of the **TableProfileRequestType** complex type.

```
<xs:complexType name="TableProfileRequestType" abstract="true">
  <xs:complexContent>
    <xs:extension base="ProfileRequestType">
      <xs:sequence>
        <xs:element name="DataSourceID" type="xs:string"
          minOccurs = "0"/>
        <xs:element name="Table" type="TableQNameType" />
      </xs:sequence>
    </xs:extension>
  </xs:complexContent>
</xs:complexType>
```

```

    </xs:sequence>
  </xs:extension>
</xs:complexContent>
</xs:complexType>

```

The following table specifies additional information about the elements in the **TableProfileRequestType** complex type.

| Element | Type definition | Description |
|---------------------|-----------------|--|
| DataSourceID | xs:string | A string value that contains an identifier for the data source for this table request. |
| Table | TableQNameType | A complex type that identifies a single table within a data source. |

2.7.1.7.1.1.2.2.4 Other Types Used by Data Profiling Task

The following types are referenced as element types by other complex types within the Data Profiling Task.

- TableQNameType
- ColumnParameterCollectionType
- ColumnParameterType
- StringCompareOptionsEnum
- StrengthThresholdSettingType

2.7.1.7.1.1.2.2.4.1 TableQNameType

The **TableQNameType** complex type is used to specify an existing table in a database.

The following is the XSD of the **TableQNameType** complex type.

```

<xs:complexType name="TableQNameType">
  <xs:attribute name="Database" type="xs:string" use="optional" />
  <xs:attribute name="Schema" type="xs:string" use="optional" />
  <xs:attribute name="Table" type="xs:string" use="optional" />
</xs:complexType>

```

The **TableQNameType** complex type MUST NOT contain elements.

The following table specifies additional information for the attributes of the **TableQNameType** complex type.

| Attribute | Description |
|-----------------|--|
| Database | A string value that specifies the name of the database in which the table resides. |
| Schema | A string value that specifies the name of the schema within the database. |
| Table | A string value that specifies the name of the table within the schema. |

2.7.1.7.1.1.2.2.4.2 ColumnParameterCollectionType

The **ColumnParameterCollectionType** complex type specifies a collection of columns that are considered as key column candidates.

The following is the XSD of the **ColumnParameterCollectionType** complex type.

```
<xs:complexType name="ColumnParameterCollectionType">
  <xs:sequence>
    <xs:element name="Column" type="ColumnParameterType"
      minOccurs="0" maxOccurs="unbounded" />
  </xs:sequence>
</xs:complexType>
```

The following table specifies additional information about the elements in the **ColumnParameterCollectionType** complex type.

| Element | Type definition | Description |
|---------------|---------------------|--|
| Column | ColumnParameterType | A complex type that specifies a single existing column by pointing to the column at its external location. |

2.7.1.7.1.1.2.2.4.2.1 **ColumnParameterType**

The **ColumnParameterType** complex type specifies a collection of columns that are considered as key column candidates.

The following is the XSD of the **ColumnParameterType** complex type.

```
<xs:complexType name="ColumnParameterType">
  <xs:attribute name="IsWildcard" type="xs:boolean"
    use="required" />
  <xs:attribute name="ColumnName" type="xs:string"
    use="optional" />
  <xs:attribute name="StringCompareOptions"
    type="DTS:StringCompareOptionsEnum"
    use="optional" />
</xs:complexType>
```

The following table specifies additional information about the elements in the **ColumnParameterType** complex type.

| Element | Type definition | Description |
|-----------------------------|--------------------------|--|
| IsWildcard | xs:boolean | This Boolean value specifies whether the wildcard character (*) has been specified to select all columns. TRUE specifies that the wildcard character has been specified; therefore, all columns in the table are selected. FALSE specifies that the wildcard character has not been specified and that specific individual columns are selected. |
| ColumnName | xs:string | A string value that specifies the name of a column. |
| StringCompareOptions | StringCompareOptionsEnum | An enumeration value that specifies the options to be used in string comparison. |

2.7.1.7.1.1.2.2.4.2.1.1 **StringCompareOptionsEnum**

The **StringCompareOptionsEnum** simple type contains the enumeration values for the **StringCompareOptions** element. **StringCompareOptionsEnum** is a bitmask, but it is a bitmask in which not all combinations are permitted. The XSD enumeration enumerates only the allowed value combinations.

The following is the XSD for the **StringCompareOptionsEnum** simple type.

```
<xs:simpleType name="StringCompareOptionsEnum">
  <xs:restriction base="xs:int">
    <xs:enumeration value="0"/>
    <xs:enumeration value="1024"/>
    <xs:enumeration value="1025"/>
    <xs:enumeration value="1026"/>
    <xs:enumeration value="1027"/>
    <xs:enumeration value="1032"/>
    <xs:enumeration value="1033"/>
    <xs:enumeration value="1034"/>
    <xs:enumeration value="1035"/>
    <xs:enumeration value="1040"/>
    <xs:enumeration value="1041"/>
    <xs:enumeration value="1042"/>
    <xs:enumeration value="1043"/>
    <xs:enumeration value="1048"/>
    <xs:enumeration value="1050"/>
    <xs:enumeration value="1051"/>
    <xs:enumeration value="32768"/>
  </xs:restriction>
</xs:simpleType>
```

The following table specifies the enumeration values for the **StringCompareOptionsEnum** type.

| Enumeration value | Description |
|-------------------|---|
| 0 | Default. |
| 1024 | Dictionary sort. |
| 1025 | Dictionary sort, ignore case. |
| 1026 | Dictionary sort, ignore non-space characters. |
| 1027 | Dictionary sort, ignore case, and ignore non-space characters. |
| 1032 | Dictionary sort, ignore kana type. |
| 1033 | Dictionary sort, ignore case, and ignore kana type. |
| 1034 | Dictionary sort, ignore non-space characters, and ignore kana type. |
| 1035 | Dictionary sort, ignore case, ignore non-space characters, and ignore kana type. |
| 1040 | Dictionary sort, ignore width. |
| 1041 | Dictionary sort, ignore case, and ignore width. |
| 1042 | Dictionary sort, ignore non-space characters, and ignore width. |
| 1043 | Dictionary sort, ignore case, ignore non-space characters, and ignore width. |
| 1048 | Dictionary sort, ignore kana type, and ignore width. |
| 1050 | Dictionary sort, ignore non-space characters, ignore kana type, and ignore width. |
| 1051 | Dictionary sort, ignore case, ignore non-space characters, ignore kana type, and ignore |

| Enumeration value | Description |
|-------------------|--------------|
| | width. |
| 32768 | Binary sort. |

2.7.1.7.1.1.2.2.4.3 **StrengthThresholdSettingType**

The **StrengthThresholdSettingType** simple type specifies the enumeration values for the **ThresholdSetting** element.

The following is the XSD of the **StrengthThresholdSettingType** simple type.

```
<xs:simpleType name="StrengthThresholdSettingType">
  <xs:restriction base="xs:string">
    <xs:enumeration value="None" />
    <xs:enumeration value="Specified" />
    <xs:enumeration value="Exact" />
  </xs:restriction>
</xs:simpleType>
```

The following table specifies the enumeration values for the **StrengthThresholdSettingType** simple type.

| Enumeration value | Description |
|-------------------|--|
| None | No threshold is specified. The key strength is reported, regardless of its value. |
| Specified | A threshold is specified as the value of the KeyStrengthThreshold element. The key strength is reported only if it is greater than the threshold. |
| Exact | No threshold is specified. The key strength is reported only if the selected columns are an exact key. |

2.7.1.7.1.1.3 **DataProfileOutputType**

The **DataProfileOutputType** complex type contains the computed profile results. [<81>](#)

The following is the XSD of the **DataProfileOutputType** type.

```
<xs:complexType name="DataProfileOutputType">
  <xs:sequence>
    <xs:element name="Profiles" type="ProfilesType"
      minOccurs="1" maxOccurs="1" />
  </xs:sequence>
</xs:complexType>
```

The following table specifies additional information about the elements and types for the **DataProfileOutputType** complex type.

| Element | Type definition | Description |
|-----------------|------------------------------|---|
| Profiles | ProfilesType | A complex type that MAY contain an output profile. <82> |

2.7.1.7.1.1.3.1 ProfilesType

The **ProfilesType** complex type contains the computed profile results. The **ProfilesType** complex type MUST be empty.

The following is the XSD of the **ProfilesType** complex type.

```
<xs:complexType name="ProfilesType">
  <xs:sequence/>
</xs:complexType>
```

2.7.1.8 Exec80PackageTaskData Element

The **Exec80PackageTaskData** element is used to specify parameters, properties, and settings that are specific to the execution of a Data Transformation Services (DTS) 2000 Package as a task. The **Exec80PackageTaskData** element resides in the [Exec80PackageTask](#) namespace. The [ExecutableObjectDataType](#) type refers to this element within an XSD **choice** element, using the XSD **ref** attribute, in the following XSD fragment.

```
<xs:element ref="Exec80PackageTask:Exec80PackageTaskData"/>
```

2.7.1.8.1 Exec80PackageTask Namespace

The **Exec80PackageTask** namespace specifies the elements and types that are used by the Execute DTS 2000 Package Task.

The following is the XSD declaration for the **Exec80PackageTask** namespace.

```
xmlns:Exec80PackageTask=
  "www.microsoft.com/sqlserver/dts/tasks/exec80packagetask"
```

2.7.1.8.1.1 Exec80PackageTaskData Element

The following is the XSD for the element declaration for the **Exec80PackageTaskData** element in the [Exec80PackageTask](#) namespace.

```
<xs:element name="Exec80PackageTaskData"
  type="Exec80PackageTask:Exec80PackageTaskType"/>
```

2.7.1.8.1.1.1 Exec80PackageTaskType

The **Exec80PackageTaskType** complex type holds parameters, properties, and settings for an Execute DTS 2000 Package Task.

The following is the XSD for the **Exec80PackageTaskType** complex type.

```
<xs:complexType name="Exec80PackageTaskType">
  <xs:sequence>
    <xs:element name="DTS2000Package" type="xs:base64Binary"
      minOccurs="0" form="unqualified"/>
  </xs:sequence>
  <xs:attribute name="Location"
    type="Exec80PackageTask:Exec80PackageTaskLocationEnum"/>
```

```

<xs:attribute name="PackageName" type="xs:string"/>
<xs:attribute name="PackageID" type="xs:string"/>
<xs:attribute name="PackageVersionGUID" type="xs:string"/>
<xs:attribute name="SQLServer" type="xs:string"/>
<xs:attribute name="SQLUsername" type="xs:string"/>
<xs:attribute name="WindowsAuthentication">
  <xs:simpleType>
    <xs:restriction base="xs:string">
      <xs:enumeration value="True"/>
      <xs:enumeration value="False"/>
    </xs:restriction>
  </xs:simpleType>
</xs:attribute>
<xs:attribute name="Filename" type="xs:string"/>
<xs:attribute name="InnerGlobalVariables" type="xs:string"/>
<xs:attribute name="OuterGlobalVariables" type="xs:string"/>
</xs:complexType>

```

The following table specifies the elements of the **Exec80PackageTaskType** complex type.

| Element | Type definition | Description |
|-----------------------|-----------------|--|
| DTS2000Package | xs:base64Binary | This element stores the content of the DTS 2000 package in binary format. If this element is present, the DTS 2000 package is not retrieved from an external location. |

The following table specifies additional information for the attributes of the **Exec80PackageTaskType** complex type.

| Attribute | Description |
|------------------------------|--|
| Location | This enumeration value specifies the storage location for the DTS 2000 package file. |
| PackageName | This string specifies the name of the DTS 2000 package that is executed. |
| PackageID | This GUID value specifies the ID of the DTS 2000 package that is executed. |
| PackageVersionGUID | A GUID value that is unique to every version of the DTS 2000 package. <83> |
| SQLServer | This string value contains the name of the server instance. <84> |
| SQLUsername | This string value contains the database username. <85> |
| WindowsAuthentication | An enumeration value that specifies whether Windows Authentication is used. "True" specifies that Windows Authentication is used. "False" specifies that Windows Authentication is not used. |
| Filename | This string value specifies the name of the file. This value is used only if the Location attribute has a value of "StorageFile". |
| InnerGlobalVariables | A string value that contains a collection of variables that are the inner variables for the task. |
| OuterGlobalVariables | A string value that contains a collection of variables that are the outer variables for the task. |

2.7.1.8.1.1.1.1 Exec80PackageTaskEnum

The **Exec80PackageTaskEnum** type contains the enumeration values for the **Location** attribute.

The following is the XSD for the **Exec80PackageTaskEnum** type.

```
<xs:simpleType name="Exec80PackageTaskLocationEnum">
  <xs:restriction base="xs:string">
    <xs:enumeration value="SqlServer"/>
    <xs:enumeration value="EmbeddedInTask"/>
    <xs:enumeration value="StorageFile"/>
  </xs:restriction>
</xs:simpleType>
```

The following table specifies the enumeration values for the **Exec80PackageTaskEnum** type.

| Enumeration value | Description |
|-----------------------|---|
| SqlServer | Specifies that the DTS 2000 Package file is stored on a database server. <86> |
| EmbeddedInTask | Specifies that the DTS 2000 Package file is embedded inline in the package file. |
| StorageFile | Specifies that the DTS 2000 Package file is stored in a file in the file system. |

2.7.1.9 ExecutePackageTaskObjectDataType

The **ExecutePackageTaskObjectDataType** complex type is used to specify parameters, properties, and settings that are specific to the Execute Package Task.

The following is the XSD for the **ExecutePackageTaskObjectDataType** complex type.

```
<xs:complexType name="ExecutePackageTaskObjectDataType">
  <xs:sequence>
    <xs:element name="ExecuteOutOfProcess" form="unqualified">
      <xs:simpleType>
        <xs:restriction base="xs:string">
          <xs:enumeration value="True"/>
          <xs:enumeration value="False"/>
        </xs:restriction>
      </xs:simpleType>
    </xs:element>
    <xs:element name="PackageName" type="xs:string"
      form="unqualified"/>
    <xs:element name="PackagePassword" type="DTS:PasswordElementType"
      form="unqualified"/>
    <xs:element name="PackageID" type="DTS:uuid" form="unqualified"/>
    <xs:element name="VersionID" type="DTS:uuid" form="unqualified"/>
    <xs:element name="Connection" type="xs:string" form="unqualified"/>
  </xs:sequence>
</xs:complexType>
```

The following table specifies the elements of the **ExecutePackageTaskObjectDataType** complex type.

| Element | Type definition | Description |
|----------------------------|------------------------------------|---|
| ExecuteOutOfProcess | Inline in the XSD in this section. | This enumeration value specifies whether the package is executed in a separate process. "True" specifies that the package is executed in a |

| Element | Type definition | Description |
|------------------------|-------------------------------------|--|
| | | separate process. "False" specifies that the package is executed within the parent process. |
| PackageName | xs:string | A string value that specifies the name of the package that is run. |
| PackagePassword | PasswordElementType | A string value that specifies the password for use if the package is encrypted. |
| PackageID | UUID | A UUID value that specifies the ID of the package that is executed. |
| VersionID | UUID | A UUID value that specifies the version ID of the version of a package to execute. |
| Connection | xs:string | A string value that specifies a reference to a connection manager by its DTSID property value or by its ObjectName property value. |

2.7.1.10 ExecuteProcessDataObjectDataType

The **ExecuteProcessDataObjectDataType** complex type is used to specify parameters, properties, and settings that are specific to the Execute Process Task.

The following is the XSD for the **ExecuteProcessDataObjectDataType** complex type.

```
<xs:complexType name="ExecuteProcessDataObjectDataType">
  <xs:sequence>
  </xs:sequence>
  <xs:attribute name="Executable" type="xs:string" form="unqualified"/>
  <xs:attribute name="RequireFullFileName" form="unqualified">
    <xs:simpleType>
      <xs:restriction base="xs:string">
        <xs:enumeration value="True"/>
        <xs:enumeration value="False"/>
      </xs:restriction>
    </xs:simpleType>
  </xs:attribute>
  <xs:attribute name="Arguments" type="xs:string" form="unqualified"/>
  <xs:attribute name="WorkingDirectory" type="xs:string"
    form="unqualified"/>

  <xs:attribute name="TimeOut" type="xs:string" form="unqualified"/>
  <xs:attribute name="FailTaskIfReturnCodeIsNotSuccessValue"
    form="unqualified">
    <xs:simpleType>
      <xs:restriction base="xs:string">
        <xs:enumeration value="True"/>
        <xs:enumeration value="False"/>
      </xs:restriction>
    </xs:simpleType>
  </xs:attribute>
  <xs:attribute name="SuccessValue" type="xs:string" form="unqualified"/>
  <xs:attribute name="TerminateAfterTimeout" form="unqualified">
    <xs:simpleType>
      <xs:restriction base="xs:string">
        <xs:enumeration value="True"/>
        <xs:enumeration value="False"/>
      </xs:restriction>
    </xs:simpleType>
  </xs:attribute>
</complexType>
```

```

</xs:attribute>
<xs:attribute name="StandardInputVariable" type="xs:string"
  form="unqualified"/>
<xs:attribute name="StandardOutputVariable" type="xs:string"
  form="unqualified"/>
<xs:attribute name="StandardErrorVariable" type="xs:string"
  form="unqualified"/>
<xs:attribute name="WindowStyle" form="unqualified"
  type="DTS:WindowStyleEnum"/>
</xs:complexType>

```

The **ExecuteProcessDataObjectDataType** complex type MUST NOT contain elements.

The following table specifies the attributes of the **ExecuteProcessDataObjectDataType** complex type.

| Attribute | Description |
|--|---|
| Executable | A string value that specifies the name of the executable to execute. |
| RequireFullFileName | An enumeration value that specifies whether the task fails if the executable is not found on the specified path. "True" specifies that the full file name is required and the task fails if the executable is not found on the specified path. "False" specifies that the full file name is not required and that the task can still execute if the executable is found in any location that is available to the process. |
| Arguments | A string value that specifies a list of arguments that is passed to the executable. |
| WorkingDirectory | A string value that specifies the working directory for the executable. |
| Timeout | An integer value that specifies the timeout interval, in seconds, for the executable. |
| FailTaskIfReturnCodeIsNotSuccessValue | An enumeration value that specifies whether the task fails if the return code is not the same as that specified for the SuccessValue attribute. "True" specifies that the task fails if the return code is not the same as the value that is specified for the SuccessValue attribute. "False" specifies that the task does not fail if the return code is not the same as the value that is specified for the SuccessValue attribute. |
| SuccessValue | An integer value that specifies the value that is returned by the external process to indicate that the external process has completed successfully. |
| TerminateAfterTimeout | An enumeration value that specifies whether the task terminates after the timeout value is reached. "True" specifies that the task terminates after the timeout value is reached. "False" specifies that the task does not terminate after the timeout value is reached. |
| StandardInputVariable | A string value that specifies a variable that contains input information that is passed to the process. |

| Attribute | Description |
|-------------------------------|--|
| StandardOutputVariable | A string value that specifies a variable where output information from the process is sent. |
| StandardErrorVariable | A string value that specifies a variable where error information from the process is sent. |
| WindowStyle | An enumeration value that specifies how the new window in which the task starts a process appears. |

2.7.1.10.1 WindowStyleEnum

The **WindowStyleEnum** type contains the enumeration values for specifying what the appearance is of the window that is created to run the process.

The following is the XSD for the **WindowStyleEnum** type.

```
<xs:simpleType name="WindowStyleEnum">
  <xs:restriction base="xs:string">
    <xs:enumeration value="Hidden"/>
    <xs:enumeration value="Maximized"/>
    <xs:enumeration value="Minimized"/>
    <xs:enumeration value="Normal"/>
  </xs:restriction>
</xs:simpleType>
```

The following table specifies the enumeration values for the **WindowStyleEnum** type.

| Enumeration value | Description |
|-------------------|---|
| Hidden | Specifies that the window is hidden. |
| Maximized | Specifies that the window is maximized. |
| Minimized | Specifies that the window is minimized. |
| Normal | Specifies that the window is normal size. |

2.7.1.11 SqlTaskData Element

The **SqlTaskData** element is used to specify parameters, properties, and settings that are specific to the execution of an Execute SQL Task. This element resides in the [SQLTask](#) namespace. The [ExecutableObjectDataType](#) type refers to this element within an XSD **choice** element by using the XSD **ref** attribute, as shown in the following XSD fragment.

```
<xs:element ref="SQLTask:SqlTaskData"/>
```

2.7.1.11.1 SQLTask Namespace

The **SQLTask** namespace specifies the elements and types that are used by the Execute SQL Task.

The following is the XSD declaration for the **SQLTask** namespace.

```
xmlns:SQLTask="www.microsoft.com/sqlserver/dts/tasks/sqltask"
```

2.7.1.11.1.1 SqlTaskData Element

The **SqlTaskData** element is used to specify parameters, properties, and settings that are specific to the execution of an Execute SQL Task. The following is the XSD for the element declaration for the [SqlTaskData](#) element in the **SQLTask** namespace.

```
<xs:element name="SqlTaskData" type="SQLTask:SqlTaskDataType"/>
```

2.7.1.11.1.1.1 SqlTaskDataType

The **SqlTaskDataType** complex type holds parameters, properties, and settings for the Execute SQL Task.

The following is the XSD for the **SqlTaskDataType** complex type.

```
<xs:complexType name="SqlTaskDataType">
  <xs:sequence>
    <xs:element name="SelectedDatabases"
      type="SQLTask:SelectedDatabasesType"
      minOccurs="0" maxOccurs="unbounded"/>
    <xs:element name="OperatorNotifyList"
      type="SQLTask:OperatorNotifyListType"
      minOccurs="0" maxOccurs="unbounded"/>
    <xs:element name="ParameterBinding"
      type="SQLTask:SqlTaskParameterBindingType"
      minOccurs="0" maxOccurs="unbounded"/>
    <xs:element name="ResultBinding"
      type="SQLTask:SqlTaskResultBindingType"
      minOccurs="0" maxOccurs="1"/>
    <xs:element name="BackupDestinationList"
      type="SQLTask:BackupDestinationListType"
      minOccurs="0" maxOccurs="unbounded"/>
  </xs:sequence>
  <xs:attributeGroup
    ref="SQLTask:SqlTaskBaseAttributeGroup"/>
  <xs:attributeGroup
    ref="SQLTask:MaintenanceTaskBaseAttributeGroup"/>
  <xs:attributeGroup
    ref="SQLTask:BackupTaskAttributeGroup"/>
  <xs:attributeGroup
    ref="SQLTask:CheckIntegrityTaskAttributeGroup"/>
  <xs:attributeGroup
    ref="SQLTask:AgentJobTaskAttributeGroup"/>
  <xs:attributeGroup
    ref="SQLTask:HistoryCleanupTaskAttributeGroup"/>
  <xs:attributeGroup
    ref="SQLTask:MaintenanceFileCleanupTaskAttributeGroup"/>
  <xs:attributeGroup
    ref="SQLTask:NotifyOperatorTaskAttributeGroup"/>
  <xs:attributeGroup
    ref="SQLTask:RebuildIndexTaskAttributeGroup"/>
  <xs:attributeGroup
    ref="SQLTask:ReorganizeIndexTaskAttributeGroup"/>
  <xs:attributeGroup
    ref="SQLTask:ShrinkDBTaskAttributeGroup"/>
  <xs:attributeGroup
    ref="SQLTask:UpdateStatisticsTaskAttributeGroup"/>
  <xs:attribute name="RemoveOlderThan" type="xs:int"/>
  <xs:attribute name="TimeUnitsType"
    type="SQLTask:SqlTaskTimeUnitsTypeEnum"/>
</complexType>
```

```

<xs:attribute name="DatabaseSelectionType"
              type="SQLTask:SqlTaskDatabaseSelectionTypeEnum"/>
</xs:complexType>

```

The following table provides additional information about the elements, types, and constraints in the **SQLTaskDataType** complex type.

| Element | Constraints | Type definition | Description |
|------------------------------|--|---|--|
| SelectedDatabases | The SelectedDatabases element MUST NOT be used except with the following tasks: Backup Task, Check Integrity Task, Rebuild Index Task, Reorganize Index Task, Shrink Database Task, and Update Statistics Task. | SelectedDatabasesType | A complex type value that specifies information about an existing database. |
| OperatorNotifyList | The OperatorNotifyList element MUST NOT be used except with the Notify Operator Task. | OperatorNotifyListType | A complex type value that specifies information about the operators to notify. |
| ParameterBinding | None. | SqlTaskParameterBindingType | A complex type value that specifies information about parameters that the Execute SQL Task uses as input or output. |
| ResultBinding | None. | SqlTaskResultBindingType | A complex type value that specifies information about the binding of the results of the execution of the Execute SQL Task. |
| BackupDestinationList | The BackupDestinationList element MUST NOT be used except with the Backup Task. | BackupDestinationListType | A complex type value that specifies information about the destinations for a Backup Task. |

The following table specifies additional information for the attributes and the attribute groups of the **SqlTaskDataType** complex type.

| Attribute | Description |
|---|---|
| SqlTaskBaseAttributeGroup | An attribute group that specifies the attributes that are common to |

| Attribute | Description |
|--|---|
| | all SQL tasks. |
| MaintenanceTaskBaseAttributeGroup | An attribute group that specifies the attributes that are common to all maintenance tasks. |
| BackupTaskAttributeGroup | An attribute group that specifies the attributes for the Backup Task. |
| CheckIntegrityTaskAttributeGroup | An attribute group that specifies the attributes for the Check Integrity Task. |
| AgentJobTaskAttributeGroup | An attribute group that specifies the attributes for the Execute SQL Agent Job Task. |
| HistoryCleanupTaskAttributeGroup | An attribute group that specifies the attributes for the History Cleanup Task. |
| MaintenanceFileCleanupTaskAttributeGroup | An attribute group that specifies the attributes for the Maintenance File Cleanup Task. |
| NotifyOperatorTaskAttributeGroup | An attribute group that specifies the attributes for the Notify Operator Task. |
| RebuildIndexTaskAttributeGroup | An attribute group that specifies the attributes for the Rebuild Index Task. |
| ReorganizeIndexTaskAttributeGroup | An attribute group that specifies the attributes for the Reorganize Index Task. |
| ShrinkDBTaskAttributeGroup | An attribute group that specifies the attributes for the Shrink Database Task. |
| UpdateStatisticsTaskAttributeGroup | An attribute group that specifies the attributes for the Update Statistics Task. |
| RemoveOlderThan | An integer value that specifies the number of units of time after which history is removed. The units for this integer value are specified by the TimeUnitsType attribute. |
| TimeUnitsType | An enumeration value that specifies the units of time for the RemoveOlderThan attribute. |
| DatabaseSelectionType | An enumeration value that specifies what types of databases are selected or whether a list of databases is specified. |

2.7.1.11.1.1.1.1.1 SqlTaskDatabaseSelectionTypeEnum

The **SqlTaskDatabaseSelectionTypeEnum** type contains the enumeration values for the **SelectionType** attribute.

The following is the XSD for the **SqlTaskDatabaseSelectionTypeEnum** type.

```
<xs:simpleType name="SqlTaskDatabaseSelectionTypeEnum">
  <xs:restriction base="xs:int">
    <xs:minInclusive value="1"/>
    <xs:maxInclusive value="4"/>
  </xs:restriction>
</xs:simpleType>
```

The following table specifies the enumeration values for the **SqlTaskDatabaseSelectionTypeEnum** type.

| Enumeration value | Description |
|-------------------|---|
| 1 | Specifies that all databases are selected. |
| 2 | Specifies that only system databases are selected. |
| 3 | Specifies that all user databases are selected. |
| 4 | Specifies that the selected databases are specified by SelectedDatabases elements. |

2.7.1.11.1.1.1.2 SqlTaskTimeUnitsTypeEnum

The **SqlTaskTimeUnitsTypeEnum** type contains the enumeration values for the **SelectionType** attribute.

The following is the XSD for the **SqlTaskTimeUnitsTypeEnum** type.

```
<xs:simpleType name="SqlTaskTimeUnitsTypeEnum">
  <xs:restriction base="xs:int">
    <xs:enumeration value="0"/>
    <xs:enumeration value="1"/>
    <xs:enumeration value="2"/>
    <xs:enumeration value="3"/>
    <xs:enumeration value="5"/>
  </xs:restriction>
</xs:simpleType>
```

The following table specifies the enumeration values for the **SqlTaskTimeUnitsTypeEnum** type.

| Enumeration value | Description |
|-------------------|--|
| 0 | The unit of time for the RemoveOlderThan attribute is days. |
| 1 | The unit of time for the RemoveOlderThan attribute is weeks. |
| 2 | The unit of time for the RemoveOlderThan attribute is months. |
| 3 | The unit of time for the RemoveOlderThan attribute is years. |
| 5 | The unit of time for the RemoveOlderThan attribute is hours. |

2.7.1.11.1.1.1.3 SelectedDatabasesType

The **SelectedDatabasesType** contains information about the databases that are selected for an Execute SQL Task operation.

The following is the XSD for the **SelectedDatabasesType** type.

```
<xs:complexType name="SelectedDatabasesType">
  <xs:sequence/>
  <xs:attribute name="DatabaseName" type="xs:string"/>
</xs:complexType>
```

The **SelectedDatabasesType** type MUST NOT contain any elements or values.

The following table specifies the attributes of the **SelectedDatabasesType** type.

| Attribute | Description |
|---------------------|--|
| DatabaseName | A string value that contains the name of an existing database. |

2.7.1.11.1.1.1.4 OperatorNotifyListType

The **OperatorNotifyListType** contains information about the databases that are selected for an Execute SQL Task operation.

The following is the XSD for the **OperatorNotifyListType** type.

```
<xs:complexType name="OperatorNotifyListType">
  <xs:sequence/>
  <xs:attribute name="OperatorNotify" type="xs:string"/>
</xs:complexType>
```

The **OperatorNotifyListType** type MUST NOT contain any elements or values.

The following table specifies the attributes of the **OperatorNotifyListType** type.

| Attribute | Description |
|-----------------------|---|
| OperatorNotify | A string value that contains the name of an operator to notify. |

2.7.1.11.1.1.1.5 SqlTaskParameterBindingType

The **SqlTaskParameterBindingType** complex type specifies information about the parameters that are used to execute an SQL statement.

The following is the XSD for the **SqlTaskParameterBindingType** complex type.

```
<xs:complexType name="SqlTaskParameterBindingType">
  <xs:sequence/>
  <xs:attribute name="ParameterName" type="xs:string"/>
  <xs:attribute name="DtsVariableName" type="xs:string"/>
  <xs:attribute name="ParameterDirection"
    type="SQLTask:ParameterDirectionEnum"/>
  <xs:attribute name="DataType" type="DTS:DtsDataTypeEnum"/>
  <xs:attribute name="ParameterSize" type="xs:int"/>
</xs:complexType>
```

The **SqlTaskParameterBindingType** complex type MUST NOT contain any elements or values.

The following table specifies the attributes of the **SqlTaskParameterBindingType** complex type.

| Attribute | Description |
|----------------------|--|
| ParameterName | A string value that specifies the name of the parameter. The format of this string value varies with the provider. |

| Attribute | Description |
|---------------------------|---|
| DtsVariableName | A string value that specifies the name of a DTS variable that provides an input value as the parameter value, receives an output value from the SQL execution, or receives a return value from the SQL execution. |
| ParameterDirection | An enumeration value that specifies the direction for the parameter. |
| Data Type | An enumeration value that specifies the data type of the parameter. |
| ParameterSize | An integer value that specifies the size of the parameter. Whether a parameter needs to have a size specified depends on the type of the parameter and the requirement of the provider. |

2.7.1.11.1.1.5.1 ParameterDirectionEnum

The **ParameterDirectionEnum** type contains the enumeration values for the **ParameterDirection** attribute.

The following is the XSD for the **ParameterDirectionEnum** type.

```
<xs:simpleType name="ParameterDirectionEnum">
  <xs:restriction base="xs:string">
    <xs:enumeration value="Input"/>
    <xs:enumeration value="Output"/>
    <xs:enumeration value="ReturnValue"/>
  </xs:restriction>
</xs:simpleType>
```

The following table specifies the enumeration values for the **ParameterDirectionEnum** type.

| Enumeration value | Description |
|--------------------|---|
| Input | Specifies that the parameter provides input to the Execute SQL Task. |
| Output | Specifies that the parameter receives output from the Execute SQL Task. |
| ReturnValue | Specifies that the parameter receives a return value from the Execute SQL Task. |

2.7.1.11.1.1.6 BackupDestinationListType

The **BackupDestinationListType** complex type specifies a list of backup destinations.

The following is the XSD for the **BackupDestinationListType** complex type.

```
<xs:complexType name="BackupDestinationListType">
  <xs:sequence/>
  <xs:attribute name="BackupDestinationLocation"
    type="xs:string"/>
</xs:complexType>
```

The **BackupDestinationListType** complex type MUST NOT contain any elements or values.

The following table specifies the attributes of the **BackupDestinationListType** complex type.

| Attribute | Description |
|----------------------------------|--|
| BackupDestinationLocation | A string value that specifies the destination location for the backup. |

2.7.1.11.1.1.1.7 SqlTaskResultBindingType

The **SqlTaskResultBindingType** specifies information about parameters that are used to execute an SQL statement.

The following is the XSD for the **SqlTaskResultBindingType** type.

```
<xs:complexType name="SqlTaskResultBindingType">
  <xs:sequence/>
  <xs:attribute name="ResultName" type="xs:string"/>
  <xs:attribute name="DtsVariableName" type="xs:string"/>
</xs:complexType>
```

The **SqlTaskResultBindingType** type MUST NOT contain any elements or values.

The following table specifies the attributes of the **SqlTaskResultBindingType** type.

| Attribute | Description |
|------------------------|---|
| ResultName | A string value that specifies the name of the result. The format of this string value varies with the provider. |
| DtsVariableName | A string value that specifies the name of a DTS variable that receives the result. |

2.7.1.11.1.1.1.8 SqlTaskBaseAttributeGroup

The **SqlTaskBaseAttributeGroup** attribute group specifies the attributes that are used by the [SqlTaskData](#) element for all tasks that use the **SqlTaskData** element.

The following is the XSD for the **SqlTaskBaseAttributeGroup** attribute group.

```
<xs:attributeGroup name="SqlTaskBaseAttributeGroup">
  <xs:attribute name="Connection" type="xs:string"/>
  <xs:attribute name="TimeOut" type="xs:int"/>
  <xs:attribute name="IsStoredProc">
    <xs:simpleType>
      <xs:restriction base="xs:string">
        <xs:enumeration value="True"/>
        <xs:enumeration value="False"/>
      </xs:restriction>
    </xs:simpleType>
  </xs:attribute>
  <xs:attribute name="BypassPrepare">
    <xs:simpleType>
      <xs:restriction base="xs:string">
        <xs:enumeration value="True"/>
        <xs:enumeration value="False"/>
      </xs:restriction>
    </xs:simpleType>
  </xs:attribute>
  <xs:attribute name="SqlStmtSourceType"
    type="DTS:SourceTypeEnum"/>
</xs:attributeGroup>
```

```

<xs:attribute name="SqlStatementSource"
  type="xs:string"/>
<xs:attribute name="CodePage" type="xs:int"/>
<xs:attribute name="ResultType"
  type="SQLTask:SqlResultTypeEnum"/>
</xs:attributeGroup>

```

The following table specifies additional information for the attributes of the **SqlTaskBaseAttributeGroup** attribute group.

| Attribute | Description |
|---------------------------|--|
| Connection | A string value that specifies a reference to a connection manager by its DTSID property value or by its ObjectName property value. |
| TimeOut | An integer that specifies the timeout interval, in seconds, for the task. |
| IsStoredProc | An enumeration value that specifies whether the Execute SQL Task executes a stored procedure. "True" specifies that the task executes a stored procedure. "False" specifies that the task does not execute a stored procedure. |
| BypassPrepare | An enumeration value that specifies whether the SQL statement is prepared before the SQL statement is executed. "True" specifies that the prepare step is bypassed and that the task is not prepared before it is executed. "False" specifies that the prepare step is not bypassed and that the task is prepared before it is executed. |
| SqlStmtSourceType | This enumeration value specifies the source of the SQL statement. |
| SqlStatementSource | This string value specifies the SQL statement. The string value can contain an SQL language statement, or it can contain identifying information for the source of the SQL statement. The content depends on the value of the SqlStmtSourceType attribute. |
| CodePage | This integer value specifies the code page for the task. |
| ResultType | This enumeration value specifies the form of the output from the task. |

2.7.1.11.1.1.8.1 SqlResultTypeEnum

The **SqlResultTypeEnum** type contains the enumeration values for the **SqlResultType** attribute.

The following is the XSD for the **SqlResultTypeEnum** type.

```

<xs:simpleType name="SqlResultTypeEnum">
  <xs:restriction base="xs:string">
    <xs:enumeration value="ResultSetType_None"/>
    <xs:enumeration value="ResultSetType_Rowset"/>
    <xs:enumeration value="ResultSetType_SingleRow"/>
    <xs:enumeration value="ResultSetType_XML"/>
  </xs:restriction>
</xs:simpleType>

```

The following table specifies the enumeration values for the **SqlResultTypeEnum** type.

| Enumeration value | Description |
|--------------------------------|---|
| ResultSetType_None | Specifies that no result set is returned. |
| ResultSetType_Rowset | Specifies that the result set that is returned is a rowset. |
| ResultSetType_SingleRow | Specifies that the result set that is returned is a single row. |
| ResultSetType_XML | Specifies that the result set that is returned is XML. |

2.7.1.11.1.1.1.9 MaintenanceTaskBaseAttributeGroup

The **MaintenanceTaskBaseAttributeGroup** attribute group specifies the attributes that are used by the [SqlTaskData](#) element by all maintenance plan tasks. The attributes that are specified in this section MUST NOT be used unless the task is one of the maintenance plan tasks.

The following is the XSD for the **MaintenanceTaskBaseAttributeGroup** attribute group.

```
<xs:attributeGroup name="MaintenanceTaskBaseAttributeGroup">
  <xs:attribute name="ServerVersion" type="xs:int"/>
  <xs:attribute name="ExtendedLogging">
    <xs:simpleType>
      <xs:restriction base="xs:string">
        <xs:enumeration value="True"/>
        <xs:enumeration value="False"/>
      </xs:restriction>
    </xs:simpleType>
  </xs:attribute>
  <xs:attribute name="LocalConnectionForLogging" type="xs:string"/>
  <xs:attribute name="TaskName" type="xs:string"/>
  <xs:attribute name="IgnoreDatabasesInNotOnlineState">
    <xs:simpleType>
      <xs:restriction base="xs:string">
        <xs:enumeration value="True"/>
        <xs:enumeration value="False"/>
      </xs:restriction>
    </xs:simpleType>
  </xs:attribute>
</xs:attributeGroup>
```

The following table specifies additional information for the attributes of the **MaintenanceTaskBaseAttributeGroup** attribute group.

| Attribute | Description |
|----------------------------------|---|
| ServerVersion | An integer value that specifies the server version. |
| ExtendedLogging | An enumeration value that specifies whether to include additional information about server operation at the end of a successful execution of a maintenance task in the log file. "True" specifies that additional information is included in the log file. "False" specifies that additional information is not included in the log file. |
| LocalConnectionForLogging | A string value that specifies a local connection manager that is used for logging. The string can reference the connection manager by pointing to the DTSID property of the connection manager or the ObjectName property of the connection manager. |
| TaskName | A string value that specifies the name of the task. |

| Attribute | Description |
|--|---|
| IgnoreDatabasesInNotOnlineState | <p>An enumeration value that specifies whether databases that are not in the online state are ignored.</p> <p>"True" specifies that databases that are not in the online state are ignored.</p> <p>"False" specifies that databases that are not in the online state are not ignored.</p> |

2.7.1.11.1.1.1.10 BackupTaskAttributeGroup

The **BackupTaskAttributeGroup** attribute group specifies the attributes that are used by the [SqlTaskData](#) element when the **ExecutableType** attribute of the containing [Executable](#) element is equal to "Microsoft.SqlServer.Management.DatabaseMaintenance.DbMaintenanceBackupTask, Microsoft.SqlServer.MaintenancePlanTasks, Version=10.0.0.0, Culture=neutral, PublicKeyToken=89845dcd8080cc91". The attributes that are specified in this section MUST NOT be used unless the **ExecutableType** attribute is equal to this value.

The following is the XSD for the **BackupTaskAttributeGroup** attribute group.

```

<xs:attributeGroup name="BackupTaskAttributeGroup">
  <xs:attribute name="BackupAction" type="SQLTask:BackupActionEnum"/>
  <xs:attribute name="BackupIsIncremental">
    <xs:simpleType>
      <xs:restriction base="xs:string">
        <xs:enumeration value="True"/>
        <xs:enumeration value="False"/>
      </xs:restriction>
    </xs:simpleType>
  </xs:attribute>
  <xs:attribute name="BackupFileGroupsFiles" type="xs:string"/>
  <xs:attribute name="BackupDeviceType"
    type="SQLTask:BackupDeviceTypeEnum"/>
  <xs:attribute name="BackupPhysicalDestinationType"
    type="SQLTask:BackupDeviceTypeEnum"/>
  <xs:attribute name="BackupDestinationType"
    type="SQLTask:DestinationTypeEnum"/>
  <xs:attribute name="BackupDestinationAutoFolderPath"
    type="xs:string"/>
  <xs:attribute name="BackupActionForExistingBackups"
    type="SQLTask:BackupActionForExistingBackupsEnum"/>
  <xs:attribute name="BackupCreateSubFolder">
    <xs:simpleType>
      <xs:restriction base="xs:string">
        <xs:enumeration value="True"/>
        <xs:enumeration value="False"/>
      </xs:restriction>
    </xs:simpleType>
  </xs:attribute>
  <xs:attribute name="BackupFileExtension" type="xs:string"/>
  <xs:attribute name="BackupVerifyIntegrity">
    <xs:simpleType>
      <xs:restriction base="xs:string">
        <xs:enumeration value="True"/>
        <xs:enumeration value="False"/>
      </xs:restriction>
    </xs:simpleType>
  </xs:attribute>
  <xs:attribute name="ExpireDate" type="xs:dateTime"/>
  <xs:attribute name="RetainDays" type="xs:int"/>
  <xs:attribute name="InDays">
    <xs:simpleType>

```

```

    <xs:restriction base="xs:string">
      <xs:enumeration value="True"/>
      <xs:enumeration value="False"/>
    </xs:restriction>
  </xs:simpleType>
</xs:attribute>
<xs:attribute name="UseExpiration">
  <xs:simpleType>
    <xs:restriction base="xs:string">
      <xs:enumeration value="True"/>
      <xs:enumeration value="False"/>
    </xs:restriction>
  </xs:simpleType>
</xs:attribute>
<xs:attribute name="BackupCompressionAction"
  type="SQLTask:BackupCompressionEnum"/>
<xs:attribute name="BackupTailLog">
  <xs:simpleType>
    <xs:restriction base="xs:string">
      <xs:enumeration value="True"/>
      <xs:enumeration value="False"/>
    </xs:restriction>
  </xs:simpleType>
</xs:attribute>
</xs:attributeGroup>

```

The following table specifies additional information for the attributes of the **BackupTaskAttributeGroup** attribute group.

| Attribute | Description |
|--|---|
| BackupAction | An enumeration value that specifies the action to be taken by the Backup Task. |
| BackupIsIncremental | An enumeration value that specifies whether the backup is incremental. "True" specifies that the backup is incremental. "False" specifies that the backup is not incremental. |
| BackupFileGroupsFiles | A string value that specifies the names of files or file groups that are to be backed up. Multiple names are specified as a comma-separated list. |
| BackupDeviceType | An enumeration value that specifies the type of device that the backup is output to. |
| BackupPhysicalDestinationType | An enumeration value that specifies the type of device that the backup is output to. If the value is 1 (tape), no rewind or unload of the backup tape is issued after the completion of the backup. |
| BackupDestinationType | An enumeration value that specifies the type of the destination for the backup. |
| BackupDestinationAutoFolderPath | A string value that specifies a folder path where further folders are created for the backup output. |
| BackupActionForExistingBackups | An enumeration value that specifies the action to take if an existing backup exists at the destination. |
| BackupCreateSubFolder | An enumeration value that specifies whether to create subfolders for the backups. "True" specifies that subfolders are created. "False" specifies that subfolders are not created. |
| BackupFileExtension | A string value that specifies the file extension for files that are created |

| Attribute | Description |
|--------------------------------|--|
| | by the backup. |
| BackupVerifyIntegrity | An enumeration value that specifies whether the task verifies the integrity of the backup after the backup file is created. "True" specifies that the task verifies the integrity of the backup file that is created. "False" specifies that the task does not verify the integrity of the backup file that is created. |
| ExpireDate | A date/time value that specifies the expiration date for the backup. |
| RetainDays | An integer value that specifies a number of days until the backup expires. |
| InDays | An enumeration value that specifies whether to use the ExpireDate attribute value or the RetainDays attribute value for the expiration of the backup. "True" specifies that the RetainDays attribute value is used to determine the backup expiration. "False" specifies that the ExpireDate attribute value is used to determine the backup expiration. |
| UseExpiration | An enumeration value that specifies whether the backup expires. "True" specifies that the backup expires. "False" specifies that the backup does not expire. |
| BackupCompressionAction | An enumeration value that specifies whether the backup is compressed, the backup is not compressed, or the default compression setting is used. |
| BackupTailLog | An enumeration value that specifies whether the Backup Task backs up the tail of the log at the end of the task. "True" specifies that the tail of the log is backed up at the end of the Backup Task. "False" specifies that the tail of the log is not backed up at the end of the Backup Task. |

2.7.1.11.1.1.10.1 BackupActionEnum

The **BackupActionEnum** type contains the enumeration values for the **BackupAction** attribute.

The following is the XSD for the **BackupActionEnum** type.

```
<xs:simpleType name="BackupActionEnum">
  <xs:restriction base="xs:int">
    <xs:minInclusive value="0"/>
    <xs:maxInclusive value="2"/>
  </xs:restriction>
</xs:simpleType>
```

The following table specifies the enumeration values for the **BackupActionEnum** type.

| Enumeration value | Description |
|-------------------|----------------------------|
| 0 | Back up a database. |
| 1 | Back up files. |
| 2 | Back up a transaction log. |

2.7.1.11.1.1.10.2 BackupDeviceTypeEnum

The **BackupDeviceTypeEnum** type contains the enumeration values for the **BackupDeviceType** attribute.

The following is the XSD for the **BackupDeviceTypeEnum** type.

```
<xs:simpleType name="BackupDeviceTypeEnum">
  <xs:restriction base="xs:int">
    <xs:minInclusive value="0"/>
    <xs:maxInclusive value="4"/>
  </xs:restriction>
</xs:simpleType>
```

The following table specifies the enumeration values for the **BackupDeviceTypeEnum** type.

| Enumeration value | Description |
|-------------------|---|
| 0 | Specifies that the backup device is a logical device. |
| 1 | Specifies that the backup device is a tape. |
| 2 | Specifies that the backup device is a file. |
| 3 | Specifies that the backup device is a pipe. |
| 4 | Specifies that the backup device is a virtual device. |

2.7.1.11.1.1.10.3 DestinationTypeEnum

The **DestinationTypeEnum** type contains the enumeration values for the **DestinationType** attribute.

The following is the XSD for the **DestinationTypeEnum** type.

```
<xs:simpleType name="DestinationTypeEnum">
  <xs:restriction base="xs:int">
    <xs:minInclusive value="0"/>
    <xs:maxInclusive value="1"/>
  </xs:restriction>
</xs:simpleType>
```

The following table specifies the enumeration values for the **DestinationTypeEnum** type.

| Enumeration value | Description |
|-------------------|---|
| 0 | Specifies that the destination is automatically determined by the task. |
| 1 | Specifies that the destination is manually set by the user. |

2.7.1.11.1.1.1.10.4 BackupActionForExistingBackupsEnum

The **BackupActionForExistingBackupsEnum** type contains the enumeration values for the **BackupActionForExistingBackups** attribute.

The following is the XSD for the **BackupActionForExistingBackupsEnum** type.

```
<xs:simpleType name="BackupActionForExistingBackupsEnum">
  <xs:restriction base="xs:int">
    <xs:minInclusive value="0"/>
    <xs:maxInclusive value="1"/>
  </xs:restriction>
</xs:simpleType>
```

The following table specifies the enumeration values for the **BackupActionForExistingBackupsEnum** type.

| Enumeration value | Description |
|-------------------|--|
| 0 | Specifies that existing backups are appended to. |
| 1 | Specifies that existing backups are overwritten. |

2.7.1.11.1.1.1.10.5 BackupCompressionActionEnum

The **BackupCompressionActionEnum** type contains the enumeration values for the **CompressionAction** attribute.

The following is the XSD for the **BackupCompressionActionEnum** type.

```
<xs:simpleType name="BackupCompressionActionEnum">
  <xs:restriction base="xs:int">
    <xs:minInclusive value="0"/>
    <xs:maxInclusive value="2"/>
  </xs:restriction>
</xs:simpleType>
```

The following table specifies the enumeration values for the **BackupCompressionActionEnum** type.

| Enumeration value | Description |
|-------------------|---|
| 0 | Specifies that the default setting for compression is used. |
| 1 | Specifies that backups are compressed. |
| 2 | Specifies that backups are not compressed. |

2.7.1.11.1.1.1.11 CheckIntegrityTaskAttributeGroup

The **CheckIntegrityTaskAttributeGroup** attribute group specifies the attributes that are used by the [SqlTaskData](#) element when the **ExecutableType** attribute of the containing Executable element is equal to the following value:

Microsoft.SqlServer.Management.DatabaseMaintenance.DbMaintenanceCheckIntegrityTask,
Microsoft.SqlServer.MaintenancePlanTasks, Version=10.0.0.0, Culture=neutral,
PublicKeyToken=89845dcd8080cc91

The attributes that are specified in this section MUST NOT be used unless the **ExecutableType** attribute is equal to this value.

The following is the XSD for the **CheckIntegrityTaskAttributeGroup** attribute group.

```
<xs:attributeGroup name="CheckIntegrityTaskAttributeGroup">  
  <xs:attribute name="IncludeIndexes">  
    <xs:simpleType>  
      <xs:restriction base="xs:string">  
        <xs:enumeration value="True"/>  
        <xs:enumeration value="False"/>  
      </xs:restriction>  
    </xs:simpleType>  
  </xs:attribute>  
</xs:attributeGroup>
```

The following table specifies additional information for the attributes of the **CheckIntegrityTaskAttributeGroup** attribute group.

| Attribute | Description |
|-----------------------|---|
| IncludeIndexes | An enumeration value that specifies whether to check the integrity of all indexes in addition to the table data pages. "True" specifies that the integrity of all indexes is checked in addition to the table data pages. "False" specifies that the integrity of only the table data pages is checked. |

2.7.1.11.1.1.1.12 AgentJobTaskAttributeGroup

The **AgentJobTaskAttributeGroup** attribute group specifies the attributes that are used by the [SqlTaskData](#) element when the **ExecutableType** attribute of the containing [Executable](#) element is equal to the following value:

Microsoft.SqlServer.Management.DatabaseMaintenance.DbMaintenanceExecuteAgentJobTask,
Microsoft.SqlServer.MaintenancePlanTasks, Version=10.0.0.0, Culture=neutral,
PublicKeyToken=89845dcd8080cc91

The attributes that are specified in this section MUST NOT be used unless the **ExecutableType** attribute is equal to this value.

The following is the XSD for the **AgentJobTaskAttributeGroup** attribute group.

```
<xs:attributeGroup name="AgentJobTaskAttributeGroup">  
  <xs:attribute name="AgentJobID" type="xs:string"/>  
</xs:attributeGroup>
```

The following table specifies additional information for the attributes of the **AgentJobTaskAttributeGroup** attribute group.

| Attribute | Description |
|-------------------|--|
| AgentJobID | A string value that specifies the Job ID for the Execute SQL Agent Job Task. |

2.7.1.11.1.1.1.13 HistoryCleanupTaskAttributeGroup

The **HistoryCleanupTaskAttributeGroup** attribute group specifies the attributes that are used by the [SqlTaskData](#) element when the **ExecutableType** attribute of the containing [Executable](#) element is equal to the following value:

Microsoft.SqlServer.Management.DatabaseMaintenance.DbMaintenanceHistoryCleanupTask, Microsoft.SqlServer.MaintenancePlanTasks, Version=10.0.0.0, Culture=neutral, PublicKeyToken=89845dcd8080cc91

The attributes that are specified in this section MUST NOT be used unless the **ExecutableType** attribute is equal to this value.

The following is the XSD for the **HistoryCleanupTaskAttributeGroup** attribute group.

```
<xs:attributeGroup name="HistoryCleanupTaskAttributeGroup">
  <xs:attribute name="RemoveBackupRestoreHistory">
    <xs:simpleType>
      <xs:restriction base="xs:string">
        <xs:enumeration value="True"/>
        <xs:enumeration value="False"/>
      </xs:restriction>
    </xs:simpleType>
  </xs:attribute>
  <xs:attribute name="RemoveAgentHistory">
    <xs:simpleType>
      <xs:restriction base="xs:string">
        <xs:enumeration value="True"/>
        <xs:enumeration value="False"/>
      </xs:restriction>
    </xs:simpleType>
  </xs:attribute>
  <xs:attribute name="RemoveDbMaintHistory">
    <xs:simpleType>
      <xs:restriction base="xs:string">
        <xs:enumeration value="True"/>
        <xs:enumeration value="False"/>
      </xs:restriction>
    </xs:simpleType>
  </xs:attribute>
</xs:attributeGroup>
```

The following table specifies additional information for the attributes of the **HistoryCleanupTaskAttributeGroup** attribute group.

| Attribute | Description |
|-----------------------------------|--|
| RemoveBackupRestoreHistory | An enumeration value that specifies whether the History Cleanup Task removes the backup restore history. "True" specifies that the History Cleanup Task removes the backup restore history. "False" specifies that the History Cleanup Task does not remove the backup |

| Attribute | Description |
|-----------------------------|---|
| | restore history. |
| RemoveAgentHistory | An enumeration value that specifies whether the History Cleanup Task removes the SQL agent history. "True" specifies that the History Cleanup Task removes the SQL agent history. "False" specifies that the History Cleanup Task does not remove the SQL agent history. |
| RemoveDBMaintHistory | An enumeration value that specifies whether the History Cleanup Task removes database maintenance history. "True" specifies that the History Cleanup Task removes the database maintenance history. "False" specifies that the History Cleanup Task does not remove the database maintenance history. |

2.7.1.11.1.1.1.14 MaintenanceFileCleanupTaskAttributeGroup

The **MaintenanceFileCleanupTaskAttributeGroup** attribute group specifies the attributes that are used by the [SqlTaskData](#) element when the **ExecutableType** attribute of the containing Executable element is equal to the following value:

Microsoft.SqlServer.Management.DatabaseMaintenance.DbMaintenanceFileCleanupTask,
Microsoft.SqlServer.MaintenancePlanTasks, Version=10.0.0.0, Culture=neutral,
PublicKeyToken=89845dcd8080cc91

The attributes that are specified in this section MUST NOT be used unless the **ExecutableType** attribute is equal to this value.

The following is the XSD for the **MaintenanceFileCleanupTaskAttributeGroup** attribute group.

```
<xs:attributeGroup name="MaintenanceFileCleanupTaskAttributeGroup">
  <xs:attribute name="FileTypeSelected" type="xs:string"/>
  <xs:attribute name="FilePath" type="xs:string"/>
  <xs:attribute name="FolderPath" type="xs:string"/>
  <xs:attribute name="CleanSubFolders">
    <xs:simpleType>
      <xs:restriction base="xs:string">
        <xs:enumeration value="True"/>
        <xs:enumeration value="False"/>
      </xs:restriction>
    </xs:simpleType>
  </xs:attribute>
  <xs:attribute name="FileExtension" type="xs:string"/>
  <xs:attribute name="AgeBased">
    <xs:simpleType>
      <xs:restriction base="xs:string">
        <xs:enumeration value="True"/>
        <xs:enumeration value="False"/>
      </xs:restriction>
    </xs:simpleType>
  </xs:attribute>
  <xs:attribute name="DeleteSpecificFile">
    <xs:simpleType>
      <xs:restriction base="xs:string">
        <xs:enumeration value="True"/>
        <xs:enumeration value="False"/>
      </xs:restriction>
    </xs:simpleType>
  </xs:attribute>
</xs:attributeGroup>
```

```

    </xs:simpleType>
  </xs:attribute>
</xs:attributeGroup>

```

The following table specifies additional information for the attributes of the **MaintenanceFileCleanupTaskAttributeGroup** attribute group.

| Attribute | Description |
|---------------------------|---|
| FileTypeSelected | An enumeration value that specifies the type of the files that are selected to be deleted. |
| FilePath | A string value that contains the path and the name of the file to be deleted. |
| FolderPath | A string value that contains the path and the name of the folder that contains the files to be deleted. |
| CleanSubFolders | An enumeration value that specifies whether the task removes files in first-level subfolders to the folder that is specified in the FolderPath attribute. "True" specifies that the task removes files in first-level subfolders to the folder that is specified in the FolderPath attribute. "False" specifies that the task does not remove files in first-level subfolders to the folder specified in the FolderPath attribute. |
| FileExtension | A string value that specifies the file extension for the files to be deleted. |
| AgeBased | An enumeration value that specifies whether the task deletes all files of the specified type that are older than the age that is specified in the RemoveOlderThan attribute. "True" specifies that the task removes all files of the specified type that are older than the specified age. "False" specifies that the task does not remove files of the specified type that are older than the specified age. |
| DeleteSpecificFile | An enumeration value that specifies whether the task deletes a specific file that is specified in the FilePath attribute. "True" specifies that the task deletes a specific file that is specified in the FilePath attribute. "False" specifies that the task does not delete a specific file that is specified in the FilePath attribute. |

2.7.1.11.1.1.14.1 SqlTaskFileTypeSelectedEnum

The **SqlTaskFileTypeSelectedEnum** type contains the enumeration values for the **FileTypeSelected** attribute.

The following is the XSD for the **SqlTaskFileTypeSelectedEnum** type.

```

<xs:simpleType name="SqlTaskFileTypeSelectedEnum">
  <xs:restriction base="xs:int">
    <xs:minInclusive value="0"/>
    <xs:maxInclusive value="1"/>
  </xs:restriction>
</xs:simpleType>

```

The following table specifies the enumeration values for the **SqlTaskFileTypeSelectedEnum** type.

| Attribute | Description |
|-----------|--|
| 0 | Specifies that backup files are selected for removal. |
| 1 | Specifies that maintenance plan text reports are selected for removal. |

2.7.1.11.1.1.1.15 NotifyOperatorTaskAttributeGroup

The **NotifyOperatorTaskAttributeGroup** attribute group specifies the attributes that are used by the [SqlTaskData](#) element when the **ExecutableType** attribute of the containing Executable element is equal to the following value:

Microsoft.SqlServer.Management.DatabaseMaintenance.DbMaintenanceNotifyOperatorTask,
Microsoft.SqlServer.MaintenancePlanTasks, Version=10.0.0.0, Culture=neutral,
PublicKeyToken=89845dcd8080cc91

The attributes that are specified in this section MUST NOT be used unless the **ExecutableType** attribute is equal to this value.

The following is the XSD for the **NotifyOperatorTaskAttributeGroup** attribute group.

```
<xs:attributeGroup name="NotifyOperatorTaskAttributeGroup">
  <xs:attribute name="Message" type="xs:string"/>
  <xs:attribute name="Profile" type="xs:string"/>
  <xs:attribute name="Subject" type="xs:string"/>
</xs:attributeGroup>
```

The following table specifies additional information for the attributes of the **NotifyOperatorTaskAttributeGroup** attribute group.

| Attribute | Description |
|-----------|---|
| Message | A string value that contains the message text for the operator notification. |
| Profile | The name of the database mail profile to send to. |
| Subject | A string value that contains the subject line text for the operator notification. |

2.7.1.11.1.1.1.16 RebuildIndexTaskAttributeGroup

The **RebuildIndexTaskAttributeGroup** attribute group specifies the attributes that are used by the [SqlTaskData](#) element when the **ExecutableType** attribute of the containing Executable element is equal to the following value:

Microsoft.SqlServer.Management.DatabaseMaintenance.DbMaintenanceReindexTask,
Microsoft.SqlServer.MaintenancePlanTasks, Version=10.0.0.0, Culture=neutral,
PublicKeyToken=89845dcd8080cc91

The attributes that are specified in this section MUST NOT be used unless the **ExecutableType** attribute is equal to this value.

The following is the XSD for the **RebuildIndexTaskAttributeGroup** attribute group.

```
<xs:attributeGroup name="RebuildIndexTaskAttributeGroup">
```

```

<xs:attribute name="UseOriginalAmount">
  <xs:simpleType>
    <xs:restriction base="xs:string">
      <xs:enumeration value="True"/>
      <xs:enumeration value="False"/>
    </xs:restriction>
  </xs:simpleType>
</xs:attribute>
<xs:attribute name="Percentage" type="xs:int"/>
<xs:attribute name="Sort">
  <xs:simpleType>
    <xs:restriction base="xs:string">
      <xs:enumeration value="True"/>
      <xs:enumeration value="False"/>
    </xs:restriction>
  </xs:simpleType>
</xs:attribute>
<xs:attribute name="KeepOnline">
  <xs:simpleType>
    <xs:restriction base="xs:string">
      <xs:enumeration value="True"/>
      <xs:enumeration value="False"/>
    </xs:restriction>
  </xs:simpleType>
</xs:attribute>
</xs:attributeGroup>

```

The following table specifies additional information for the attributes of the **RebuildIndexTaskAttributeGroup** attribute group.

| Attribute | Description |
|--------------------------|--|
| UseOriginalAmount | An enumeration value that specifies that the indexes are rebuilt with the same amount of free space as was allocated when the index was created. "True" specifies that indexes are rebuilt with the amount of free space that was allocated when the index was created. "False" specifies that indexes are not rebuilt with the amount of free space that was allocated when the index was created. |
| Percentage | An integer value that specifies the percentage of free space to allocate in the rebuilt indexes. |
| Sort | An enumeration value that specifies whether sorts that are required during the rebuild index operation are performed in a temporary database. "True" specifies that any sorts that are required during the rebuild index operation are performed in a temporary database. "False" specifies that any sorts that are required during the rebuild index operation are not performed in a temporary database. |
| KeepOnline | An enumeration value that specifies whether the database is to be kept online during the rebuild index operation. "True" specifies that the index is to be kept online during the rebuild index operation. "False" specifies that the index is not to be kept online during the rebuild index operation. |

2.7.1.11.1.1.1.17 ReorganizeIndexTaskAttributeGroup

The **ReorganizeIndexTaskAttributeGroup** attribute group specifies the attributes that are utilized by the [SqlTaskData](#) element when the **ExecutableType** attribute of the containing Executable element is equal to the following value:

Microsoft.SqlServer.Management.DatabaseMaintenance.DbMaintenanceDefragmentIndexTask,
Microsoft.SqlServer.MaintenancePlanTasks, Version=10.0.0.0, Culture=neutral,
PublicKeyToken=89845dcd8080cc91

The attributes that are specified in this section MUST NOT be used unless the **ExecutableType** attribute is equal to this value.

The following is the XSD for the **ReorganizeIndexTaskAttributeGroup** attribute group.

```
<xs:attributeGroup name="ReorganizeIndexTaskAttributeGroup">  
  <xs:attribute name="CompactLargeObjects">  
    <xs:simpleType>  
      <xs:restriction base="xs:string">  
        <xs:enumeration value="True"/>  
        <xs:enumeration value="False"/>  
      </xs:restriction>  
    </xs:simpleType>  
  </xs:attribute>  
</xs:attributeGroup>
```

The following table specifies additional information for the attributes of the **ReorganizeIndexTaskAttributeGroup** attribute group.

| Attribute | Description |
|----------------------------|---|
| CompactLargeObjects | An enumeration value that specifies whether space for tables and views is deallocated when possible. "True" specifies that space for tables and views is deallocated when possible. "False" specifies that large objects are not compacted by the task. |

2.7.1.11.1.1.1.18 ShrinkDBTaskAttributeGroup

The **ShrinkDBTaskAttributeGroup** attribute group specifies the attributes that are used by the [SqlTaskData](#) element when the **ExecutableType** attribute of the containing Executable element is equal to the following value:

Microsoft.SqlServer.Management.DatabaseMaintenance.DbMaintenanceShrinkTask,
Microsoft.SqlServer.MaintenancePlanTasks, Version=10.0.0.0, Culture=neutral,
PublicKeyToken=89845dcd8080cc91

The attributes that are specified in this section MUST NOT be used unless the **ExecutableType** attribute is equal to this value.

The following is the XSD for the **ShrinkDBTaskAttributeGroup** attribute group.

```
<xs:attributeGroup name="ShrinkDBTaskAttributeGroup">  
  <xs:attribute name="DatabaseSizeLimit" type="xs:int"/>  
  <xs:attribute name="DatabasePercentLimit" type="xs:int"/>  
  <xs:attribute name="DatabaseReturnFreeSpace">  
    <xs:simpleType>  
      <xs:restriction base="xs:string">  
        <xs:enumeration value="True"/>  
        <xs:enumeration value="False"/>  
      </xs:restriction>  
    </xs:simpleType>  
  </xs:attribute>  
</xs:attributeGroup>
```

The following table specifies additional information for the attributes of the **ShrinkDBTaskAttributeGroup** attribute group.

| Attribute | Description |
|--------------------------------|--|
| DatabaseSizeLimit | An integer that specifies the size limit of the database in megabytes. |
| DatabasePercentLimit | An integer that specifies the limit of free space in units of percent. When free space in the database falls below the percentage represented by the integer value, shrinking of the database stops. |
| DatabaseReturnFreeSpace | An enumeration value that specifies whether to retain free space in the database file or to return it to the operating system. "True" specifies that free space is returned to the operating system. "False" specifies that free space is retained in the database file. |

2.7.1.11.1.1.1.19 UpdateStatisticsTaskAttributeGroup

The **UpdateStatisticsTaskAttributeGroup** attribute group specifies the attributes that are used by the [SqlTaskData](#) element when the **ExecutableType** attribute of the containing Executable element is equal to "". The attributes that are specified in this section MUST NOT be used unless the **ExecutableType** attribute is equal to this value.

The following is the XSD for the **UpdateStatisticsTaskAttributeGroup** attribute group.

```
<xs:attributeGroup name="UpdateStatisticsTaskAttributeGroup">
  <xs:attribute name="UpdateStatisticsType"
    type="SQLTask:SqlTaskUpdateStatisticsTypeEnum"/>
  <xs:attribute name="UpdateScanType"
    type="SQLTask:SqlTaskUpdateScanTypeEnum"/>
  <xs:attribute name="UpdateSampleValue" type="xs:int"/>
</xs:attributeGroup>
```

The following table specifies additional information for the attributes of the **UpdateStatisticsTaskAttributeGroup** attribute group.

| Attribute | Description |
|-----------------------------|---|
| UpdateStatisticsType | An enumeration value that specifies the database objects that have updated statistics. |
| UpdateScanType | An enumeration value that specifies the type of scan to perform for statistics gathering. |
| UpdateSampleValue | An integer value for which the interpretation is based on the value of the UpdateScanType attribute. This integer value can represent a percentage or a count of rows. |

2.7.1.11.1.1.1.19.1 SqlTaskUpdateStatisticsTypeEnum (1)

The **SqlTaskUpdateStatisticsTypeEnum** type contains the enumeration values for the **UpdateStatisticsType** attribute.

The following is the XSD for the **SqlTaskUpdateStatisticsTypeEnum** type.

```
<xs:simpleType name="SqlTaskUpdateStatisticsTypeEnum">
```

```

    <xs:restriction base="xs:int">
      <xs:minInclusive value="0"/>
      <xs:maxInclusive value="2"/>
    </xs:restriction>
  </xs:simpleType>

```

The following table specifies the enumeration values for the **SqlTaskUpdateStatisticsTypeEnum** type.

| Enumeration value | Description |
|-------------------|---|
| 0 | Specifies that statistics are updated for indexes only. |
| 1 | Specifies that only column statistics are updated. |
| 2 | Specifies that all existing statistics are updated. |

2.7.1.11.1.1.19.2 SqlTaskUpdateStatisticsTypeEnum (2)

The **SqlTaskUpdateStatisticsTypeEnum** type contains the enumeration values for the **UpdateStatisticsType** attribute.

The following is the XSD for the **SqlTaskUpdateStatisticsTypeEnum** type.

```

<xs:simpleType name="SqlTaskUpdateStatisticsTypeEnum">
  <xs:restriction base="xs:int">
    <xs:minInclusive value="0"/>
    <xs:maxInclusive value="2"/>
  </xs:restriction>
</xs:simpleType>

```

The following table specifies the enumeration values for the **SqlTaskUpdateStatisticsTypeEnum** type.

| Enumeration value | Description |
|-------------------|---|
| 0 | Specifies that statistics are updated for indexes only. |
| 1 | Specifies that only column statistics are updated. |
| 2 | Specifies that all existing statistics are updated. |

2.7.1.11.1.1.1.20 Execute TSQL Task

The Execute TSQL Task has no attributes that it adds to the [SqlTaskData](#) element. When the **ExecutableType** attribute of the containing [Executable](#) element is equal to "Microsoft.SqlServer.Management.DatabaseMaintenance.DbMaintenanceTSQLExecuteTask, Microsoft.SqlServer.MaintenancePlanTasks, Version=10.0.0.0, Culture=neutral, PublicKeyToken=89845dcd8080cc91", there MUST NOT be any attributes for the **SqlTaskData** element beyond those that are specified in the [SqlTaskBaseAttributeGroup](#) attribute group and the [MaintenanceTaskBaseAttributeGroup](#) attribute group.

2.7.1.12 FileSystemDataObjectDataType

The **FileSystemDataObjectDataType** complex type is used to specify settings and parameters that are specific to the File System Task.

The following is the XSD for the **FileSystemDataObjectDataType** complex type.

```
<xs:complexType name="FileSystemDataObjectDataType">
  <xs:sequence/>
  <xs:attribute name="TaskOperationType" form="unqualified"
    type="DTS:FileSystemTaskOperationTypeEnum"/>
  <xs:attribute name="OperationName" form="unqualified"
    type="xs:string"/>
  <xs:attribute name="TaskOverwriteDestFile" form="unqualified">
    <xs:simpleType>
      <xs:restriction base="xs:string">
        <xs:enumeration value="False"/>
        <xs:enumeration value="True"/>
      </xs:restriction>
    </xs:simpleType>
  </xs:attribute>
  <xs:attribute name="TaskSourcePath" form="unqualified"
    type="xs:string"/>
  <xs:attribute name="TaskIsSourceVariable" form="unqualified">
    <xs:simpleType>
      <xs:restriction base="xs:string">
        <xs:enumeration value="False"/>
        <xs:enumeration value="True"/>
      </xs:restriction>
    </xs:simpleType>
  </xs:attribute>
  <xs:attribute name="TaskDestinationPath" form="unqualified"
    type="xs:string"/>
  <xs:attribute name="TaskIsDestinationVariable" form="unqualified">
    <xs:simpleType>
      <xs:restriction base="xs:string">
        <xs:enumeration value="False"/>
        <xs:enumeration value="True"/>
      </xs:restriction>
    </xs:simpleType>
  </xs:attribute>
  <xs:attribute name="TaskFileAttributes" form="unqualified"
    type="DTS:FileSystemTaskFileAttributesEnum"/>
</xs:complexType>
```

The **FileSystemDataObjectDataType** complex type MUST NOT have child elements.

The following table provides additional information about the attributes in the **FileSystemDataObjectDataType** complex type.

| Attribute | Description |
|------------------------------|---|
| TaskOperationType | This enumeration value specifies the type of file system task that is performed. |
| OperationName | This string value contains the name given to the operation. |
| TaskOverwriteDestFile | This enumeration value specifies whether the destination file can be overwritten. "True" specifies that the destination file can be overwritten. "False" specifies that the destination file cannot be overwritten. |
| TaskSourcePath | This string value represents the source file path. It contains either the DTSID property of a defined ConnectionManager object or a string that contains the name of a variable. |

| Attribute | Description |
|----------------------------------|--|
| TaskIsSourceVariable | This enumeration value specifies whether a variable or a file connection manager specifies the source path. "True" specifies that the TaskSourcePath is a variable. "False" specifies that the TaskSourcePath is a file connection manager. |
| TaskDestinationPath | This string value represents the destination file path. It contains either the DTSID property of a defined ConnectionManager object or a string that contains the name of a variable. |
| TaskIsDestinationVariable | This enumeration value specifies whether a variable or a file connection manager specifies the destination path. "True" specifies that the TaskDestinationPath value is a variable. "False" specifies that the TaskDestinationPath value is a file connection manager. |
| TaskFileAttributes | This enumeration value specifies the file attributes for the file system file. |

2.7.1.12.1 FileSystemTaskOperationTypeEnum

The **FileSystemTaskOperationTypeEnum** type contains the allowed enumeration values for the **FileSystemTaskOperationType** attribute of the **FileSystemDataObjectDataType** type.

The following is the XSD for the **FileSystemTaskOperationTypeEnum** type.

```
<xs:simpleType name="FileSystemTaskOperationTypeEnum">
  <xs:restriction base="xs:string">
    <xs:enumeration value="CopyFile" />
    <xs:enumeration value="CreateDirectory" />
    <xs:enumeration value="DeleteDirectory" />
    <xs:enumeration value="DeleteFile" />
    <xs:enumeration value="MoveDirectory" />
    <xs:enumeration value="MoveFile" />
    <xs:enumeration value="RenameFile" />
    <xs:enumeration value="SetAttributes" />
    <xs:enumeration value="DeleteDirectoryContent" />
    <xs:enumeration value="CopyDirectory" />
  </xs:restriction>
</xs:simpleType>
```

The following table specifies the enumeration values for the **FileSystemTaskOperationTypeEnum** type.

| Enumeration value | Description |
|------------------------|--|
| CopyFile | Specifies that the task operation copies a file. |
| CreateDirectory | Specifies that the task operation creates a directory. |
| DeleteDirectory | Specifies that the task operation deletes a directory. |
| DeleteFile | Specifies that the task operation deletes a file. |
| MoveDirectory | Specifies that the task operation moves a directory. |
| MoveFile | Specifies that the task operation moves a file. |

| Enumeration value | Description |
|-------------------------------|---|
| RenameFile | Specifies that the task operation renames a file. |
| SetAttributes | Specifies that the task operation sets attributes. |
| DeleteDirectoryContent | Specifies that the task operation deletes directory contents. |
| CopyDirectory | Specifies that the task operation copies a directory. |

2.7.1.12.2 FileSystemTaskFileAttributesEnum

The **FileSystemTaskFileAttributesEnum** type contains the allowed enumeration values for the **TaskFileAttributes** attribute of the **FileSystemDataObjectDataType** type.

The following is the XSD for the **FileSystemTaskFileAttributesEnum** type.

```
<xs:simpleType name="FileSystemTaskFileAttributesEnum">
  <xs:restriction base="xs:string">
    <xs:enumeration value="Archive" />
    <xs:enumeration value="Hidden" />
    <xs:enumeration value="Normal" />
    <xs:enumeration value="ReadOnly" />
    <xs:enumeration value="System" />
  </xs:restriction>
</xs:simpleType>
```

The following table specifies the enumeration values for the **FileSystemTaskFileAttributesEnum** type.

| Enumeration value | Description |
|-------------------|--|
| Archive | This enumeration value specifies that the Archive attribute of the file MUST be set by the task. |
| Hidden | This enumeration value specifies that the Hidden attribute of the file MUST be set by the task. |
| Normal | This enumeration value specifies that the file is normal and that none of the file attributes MUST be set by the task. |
| ReadOnly | This enumeration value specifies that the ReadOnly attribute of the file MUST be set by the task. |
| System | This enumeration value specifies that the System attribute of the file MUST be set by the task. |

2.7.1.13 FtpDataObjectDataType

The **FtpDataObjectDataType** complex type is used to specify parameters, properties, and settings that are specific to the FTP Task.

The following is the XSD of the **FtpDataObjectDataType** complex type.

```
<xs:complexType name="FtpDataObjectDataType">
```

```

<xs:sequence>
</xs:sequence>
<xs:attribute name="ConnectionName" type="xs:string"
  form="unqualified"/>
<xs:attribute name="StopOnFailure" form="unqualified">
  <xs:simpleType>
    <xs:restriction base="xs:string">
      <xs:enumeration value="False"/>
      <xs:enumeration value="True"/>
    </xs:restriction>
  </xs:simpleType>
</xs:attribute>
<xs:attribute name="TaskOperationType" type="xs:string"
  form="unqualified"/>
<xs:attribute name="TaskOperationName" type="xs:string"
  form="unqualified"/>
<xs:attribute name="TaskIsLocalPathVar" form="unqualified">
  <xs:simpleType>
    <xs:restriction base="xs:string">
      <xs:enumeration value="False"/>
      <xs:enumeration value="True"/>
    </xs:restriction>
  </xs:simpleType>
</xs:attribute>
<xs:attribute name="TaskLocalPath" type="xs:string"
  form="unqualified"/>
<xs:attribute name="TaskIsRemotePathVar" form="unqualified">
  <xs:simpleType>
    <xs:restriction base="xs:string">
      <xs:enumeration value="False"/>
      <xs:enumeration value="True"/>
    </xs:restriction>
  </xs:simpleType>
</xs:attribute>
<xs:attribute name="TaskRemotePath" type="xs:string"
  form="unqualified"/>
<xs:attribute name="TaskOverwriteDest" form="unqualified">
  <xs:simpleType>
    <xs:restriction base="xs:string">
      <xs:enumeration value="False"/>
      <xs:enumeration value="True"/>
    </xs:restriction>
  </xs:simpleType>
</xs:attribute>
<xs:attribute name="TaskTransferAscii" form="unqualified">
  <xs:simpleType>
    <xs:restriction base="xs:string">
      <xs:enumeration value="False"/>
      <xs:enumeration value="True"/>
    </xs:restriction>
  </xs:simpleType>
</xs:attribute>
</xs:complexType>

```

The **FtpDataObjectDataType** complex type MUST NOT contain elements.

The following table specifies the attributes of the **FtpDataObjectDataType** type.

| Attribute | Description |
|-----------------------|---|
| ConnectionName | A string value that specifies a reference to a connection manager by its DTSID property value or by its ObjectName property value. |
| StopOnFailure | An enumeration value that specifies whether the task fails if the FTP operation fails. "True" specifies that the task fails if the FTP operation fails. |

| Attribute | Description |
|----------------------------|---|
| | "False" specifies that the task does not fail if the FTP operation fails. |
| TaskOperationType | An enumeration value that specifies the FTP operation that the task performs. |
| TaskOperationName | A string value that specifies a name that is given to the operation. |
| TaskIsLocalPathVar | An enumeration value that specifies whether the TaskLocalPath attribute contains the name of a variable. "True" specifies that the TaskLocalPath attribute contains a variable name. "False" specifies that the TaskLocalPath attribute does not contain a variable name. |
| TaskLocalPath | A string value that specifies the path in the local location or, if the TaskIsLocalPathVar attribute is equal to "True", a string value that specifies the name of the variable. |
| TaskIsRemotePathVar | An enumeration value that specifies whether the TaskRemotePath attribute contains the name of a variable. "True" specifies that the TaskRemotePath attribute contains a variable name. "False" specifies that the TaskRemotePath attribute does not contain a variable name. |
| TaskRemotePath | A string value that specifies the path in the remote location or, if the TaskIsRemotePathVar attribute is equal to "True", a string value that specifies the name of the variable. |
| TaskOverwriteDest | An enumeration value specifies whether the FTP operation can overwrite objects at the destination. "True" specifies that the task can overwrite objects at the destination. "False" specifies that the task cannot overwrite objects at the destination. |
| TaskTransferAscii | An enumeration value specifies whether file transfer is performed in ASCII mode. "True" specifies that file transfer is performed in ASCII mode. "False" specifies that file transfer is not performed in ASCII mode. |

2.7.1.13.1 FtpDataTaskOperationTypeEnum

The **FtpDataTaskOperationTypeEnum** type contains the enumeration values for specifying what FTP operation is performed.

The following is the XSD for the **FtpDataTaskOperationTypeEnum** type.

```
<xs:simpleType name="FtpDataTaskOperationTypeEnum">
  <xs:restriction base="xs:string">
    <xs:enumeration value="DeleteLocal"/>
    <xs:enumeration value="DeleteRemote"/>
    <xs:enumeration value="MakeDirLocal"/>
    <xs:enumeration value="MakeDirRemote"/>
    <xs:enumeration value="Receive"/>
    <xs:enumeration value="RemoveDirLocal"/>
    <xs:enumeration value="RemoveDirRemote"/>
    <xs:enumeration value="Send"/>
  </xs:restriction>
</xs:simpleType>
```

The following table specifies the enumeration values for the **FtpDataTaskOperationTypeEnum** type.

| Enumeration value | Description |
|------------------------|--|
| DeleteLocal | Specifies that the FTP operation deletes a local file. |
| DeleteRemote | Specifies that the FTP operation deletes a remote file. |
| MakeDirLocal | Specifies that the FTP operation creates a local directory. |
| MakeDirRemote | Specifies that the FTP operation creates a remote directory. |
| Receive | Specifies that the FTP operation receives a file or directory. |
| RemoveDirLocal | Specifies that the FTP operation removes a local directory. |
| RemoveDirRemote | Specifies that the FTP operation removes a remote directory. |
| Send | Specifies that the FTP operation sends a file or directory. |

2.7.1.14 MessageQueueTaskData Element

The **MessageQueueTaskData** element is used to specify parameters, properties, and settings that are specific to the execution of a Message Queue Task. The **MessageQueueTaskData** element resides in the [MessageQueueTask](#) namespace. The [ExecutableObjectDataType](#) type refers to the **MessageQueueTaskData** element within an XSD **choice** element, using the XSD **ref** attribute, in the following XSD fragment.

```
<xs:element ref="MessageQueueTask:MessageQueueTaskData"/>
```

2.7.1.14.1 MessageQueueTask Namespace

The **MessageQueueTask** namespace specifies the elements and types that are used by the Message Queue Task.

The following is the XSD declaration for the **MessageQueueTask** namespace.

```
xmlns:MessageQueueTask="www.microsoft.com/sqlserver/dts/tasks/messagequeuetask"
```

2.7.1.14.1.1 MessageQueueTaskData Element

The following is the XSD for the element declaration for the **MessageQueueTaskData** element in the [MessageQueueTask](#) namespace.

```
<xs:element name="MessageQueueTaskData"
  type="MessageQueueTask:MessageQueueTaskType"/>
```

2.7.1.14.1.1.1 MessageQueueTaskType

The **MessageQueueTaskType** complex type holds parameters, properties, and settings for the Message Queue Task.

The following is the XSD for the **MessageQueueTaskType** complex type.

```
<xs:complexType name="MessageQueueTaskType">
```



```

<xs:sequence>
</xs:sequence>
<xs:attribute name="CurrentPackageID" type="DTS:uuid"/>
<xs:attribute name="TaskDescription" type="xs:string"/>
<xs:attribute name="DataFileOverWritable">
  <xs:simpleType>
    <xs:restriction base="xs:string">
      <xs:enumeration value="False"/>
      <xs:enumeration value="True"/>
    </xs:restriction>
  </xs:simpleType>
</xs:attribute>
<xs:attribute name="DTSMMessageLineageID" type="xs:string"/>
<xs:attribute name="DTSMMessagePackageID" type="xs:string"/>
<xs:attribute name="DTSMMessageVersionID" type="xs:string"/>
<xs:attribute name="ErrorIfMessageTimeOut">
  <xs:simpleType>
    <xs:restriction base="xs:string">
      <xs:enumeration value="False"/>
      <xs:enumeration value="True"/>
    </xs:restriction>
  </xs:simpleType>
</xs:attribute>
<xs:attribute name="QueuePath" type="xs:string"/>
<xs:attribute name="ReceiveMessageTimeOut" type="xs:int"/>
<xs:attribute name="ReceiveMessageType"
  type="MessageQueueTask:MSMQMessageTypeEnum"/>
<xs:attribute name="RemoveFromQueue">
  <xs:simpleType>
    <xs:restriction base="xs:string">
      <xs:enumeration value="False"/>
      <xs:enumeration value="True"/>
    </xs:restriction>
  </xs:simpleType>
</xs:attribute>
<xs:attribute name="SaveDataFileName" type="xs:string"/>
<xs:attribute name="StringCompareType"
  type="MessageQueueTask:MSMQStringCompareTypeEnum"/>
<xs:attribute name="StringCompareValue" type="xs:string"/>
<xs:attribute name="StringMessageToVariableName" type="xs:string"/>
<xs:attribute name="ReceiveVariableMessage" type="xs:string"/>
<xs:attribute name="TaskType"
  type="MessageQueueTask:MSMQTaskTypeEnum"/>
<xs:attribute name="UseEncryption">
  <xs:simpleType>
    <xs:restriction base="xs:string">
      <xs:enumeration value="False"/>
      <xs:enumeration value="True"/>
    </xs:restriction>
  </xs:simpleType>
</xs:attribute>
<xs:attribute name="EncryptionAlgorithm"
  type="MessageQueueTask:MSMQEncryptionAlgorithmEnum"/>
<xs:attribute name="Use2000Format">
  <xs:simpleType>
    <xs:restriction base="xs:string">
      <xs:enumeration value="False"/>
      <xs:enumeration value="True"/>
    </xs:restriction>
  </xs:simpleType>
</xs:attribute>
<xs:attribute name="DataFileName" type="xs:string"/>
<xs:attribute name="StringMessage" type="xs:string"/>
<xs:attribute name="VariableMessage" type="xs:string"/>
<xs:attribute name="MessageType"
  type="MessageQueueTask:MSMQMessageTypeEnum"/>
</xs:complexType>

```

The **MessageQueueTaskType** complex type MUST NOT contain elements.

The following table specifies additional information for the attributes of the **MessageQueueTaskType** complex type.

| Attribute | Description |
|------------------------------------|--|
| CurrentPackageID | A UUID value that specifies the DTSID attribute of the currently executing package. |
| TaskDescription | A string value that specifies a description for the task. |
| DataFileOverWritable | An enumeration value that specifies whether the message can overwrite an existing file. This enumeration value applies only if the MessageType attribute is equal to "DTSMQMessageType_DataFile". "True" specifies that the task can overwrite a file. "False" specifies that the task cannot overwrite a file. |
| DTSMessageLineageID | A string value. <87> |
| DTSMessagePackageID | A UUID value that specifies the DTSID property of the package that is the source of the message. |
| DTSMessageVersionID | A string value that specifies the version of the message. |
| ErrorIfMessageTimeOut | An enumeration value that specifies whether the task fails when the message times out. "True" specifies that the task always fails when the message times out. "False" specifies that the task does not necessarily fail when the message times out. |
| QueuePath | A string value that specifies the ObjectName property of a connection manager for this message queue. |
| ReceiveMessageTimeOut | An integer value that specifies the number of seconds that elapse before a received message times out. |
| ReceiveMessageType | An enumeration value that specifies the type of the received message. |
| RemoveFromQueue | An enumeration value that specifies whether to remove the message from the queue. "True" specifies that the message MUST be removed from the queue. "False" specifies that the message MUST NOT be removed from the queue. |
| SaveDataFileName | A string value that specifies the name of the file to which an incoming message is saved. |
| StringCompareType | An enumeration value that specifies the string comparison method. This enumeration value is used only when the TaskType attribute is set to the value "DTSMQType_Receiver". |
| StringCompareValue | A string value that specifies a string to which a string message is compared when the TaskType attribute is set to "DTSMQType_Receiver". |
| StringMessageToVariableName | A string value that specifies the name of the variable to which the message contents are saved. |
| ReceiveVariableMessage | A string value that specifies the name of the variable where a received message is saved. |
| TaskType | An enumeration value that specifies whether the task is sending a message or receiving a message. |

| Attribute | Description |
|----------------------------|---|
| UseEncryption | An enumeration value that specifies whether to encrypt the messages. "True" specifies that the message MUST be encrypted. "False" specifies that the message MUST NOT be encrypted. |
| EncryptionAlgorithm | An enumeration value that specifies the encryption algorithm to use. |
| Use2000Format | An enumeration value that specifies whether the message is formatted in a specific format. <88> |
| DataFileName | A string value that specifies the name of the file that is used if the message type uses a file. |
| StringMessage | A string value that contains the message text. This string value is used only if the MessageType attribute is set to the "DTSMQMessageType_String" value. |
| VariableMessage | A string value that contains the message text. This string value is used only if the MessageType attribute is set to the "DTSMQMessageType_Variables" value. |
| MessageType | An enumeration value that specifies the type of message that is sent. This enumeration value is used only when the TaskType attribute is set to "DTSMQType_Sender". |

2.7.1.14.1.1.1 MSMQStringCompareTypeEnum

The **MSMQStringCompareTypeEnum** type contains the enumeration values for the **StringCompareType** attribute.

The following is the XSD of the **MSMQStringCompareTypeEnum** type.

```
<xs:simpleType name="MSMQStringCompareTypeEnum">
  <xs:restriction base="xs:string">
    <xs:enumeration value="DTSMQStringMessageCompare_Contains"/>
    <xs:enumeration value="DTSMQStringMessageCompare_Exact"/>
    <xs:enumeration value="DTSMQStringMessageCompare_IgnoreCase"/>
    <xs:enumeration value="DTSMQStringMessageCompare_None"/>
  </xs:restriction>
</xs:simpleType>
```

The following table specifies the enumeration values for the **MSMQStringCompareTypeEnum** type.

| Enumeration value | Description |
|---|--|
| DTSMQStringMessageCompare_Contains | Specifies that the comparison operation is successful if the received message contains the comparison string. |
| DTSMQStringMessageCompare_Exact | Specifies that the comparison operation is successful if the received message exactly matches the comparison string. |
| DTSMQStringMessageCompare_IgnoreCase | Specifies that the comparison operation is successful if the received message matches the comparison string, ignoring the case of letters. |
| DTSMQStringMessageCompare_None | Specifies that no comparison operation is performed. |

2.7.1.14.1.1.1.2 MSMQTaskTypeEnum

The **MSMQTaskTypeEnum** type contains the enumeration values for the **TaskType** attribute.

The following is the XSD of the **MSMQTaskTypeEnum** type.

```
<xs:simpleType name="MSMQTaskTypeEnum">
  <xs:restriction base="xs:string">
    <xs:enumeration value="DTSMQType_Receiver"/>
    <xs:enumeration value="DTSMQType_Sender"/>
  </xs:restriction>
</xs:simpleType>
```

The following table specifies the enumeration values for the **MSMQTaskTypeEnum** type.

| Enumeration value | Description |
|---------------------------|--|
| DTSMQType_Receiver | Specifies that the task receives messages. |
| DTSMQType_Sender | Specifies that the task sends messages. |

2.7.1.14.1.1.1.3 MSMQMessageTypeEnum

The **MSMQMessageTypeEnum** type contains the enumeration values for the **MessageType** attribute.

The following is the XSD of the **MSMQMessageTypeEnum** type.

```
<xs:simpleType name="MSMQMessageTypeEnum">
  <xs:restriction base="xs:string">
    <xs:enumeration value="DTSMQMessageAgType_StringMessageToVariable"/>
    <xs:enumeration value="DTSMQMessageType_DataFile"/>
    <xs:enumeration value="DTSMQMessageType_String"/>
    <xs:enumeration value="DTSMQMessageType_Variables"/>
  </xs:restriction>
</xs:simpleType>
```

The following table specifies the enumeration values for the **MSMQMessageTypeEnum** type.

| Enumeration value | Description |
|---|---|
| DTSMQMessageAgType_StringMessageToVariable | Specifies that the message source is text and that the message destination is a variable. This value is valid only if the TaskType attribute is equal to "DTSMQType_Sender". |
| DTSMQMessageType_DataFile | Specifies that the message source is a data file. |
| DTSMQMessageType_String | Specifies that the message source is a string. |
| DTSMQMessageType_Variables | Specifies that the message source is a variable and that the message destination is also a variable. |

2.7.1.14.1.1.1.4 MSMQEncryptionAlgorithmEnum

The **MSMQEncryptionAlgorithmEnum** type contains the enumeration values for the **EncryptionAlgorithm** attribute.

The following is the XSD of the **MSMQEncryptionAlgorithmEnum** type.

```
<xs:simpleType name="MSMQEncryptionAlgorithmEnum">
  <xs:restriction base="xs:string">
    <xs:enumeration value="Rc2"/>
    <xs:enumeration value="Rc4"/>
  </xs:restriction>
</xs:simpleType>
```

The following table specifies the enumeration values for the **MSMQEncryptionAlgorithmEnum** type.

| Enumeration value | Description |
|-------------------|--|
| Rc2 | Specifies that the RC2 encryption algorithm is used [RFC2268] . |
| Rc4 | Specifies that the RC4 encryption algorithm is used [SCAN-RC4] . |

2.7.1.15 ScriptProjectObjectType

The **ScriptProjectObjectType** complex type is used to specify parameters, properties, and settings that are specific to the Script Task.

The following is the XSD of the **ScriptProjectObjectType** complex type.

```
<xs:complexType name="ScriptProjectObjectType">
  <xs:sequence>
    <xs:element name="ProjectItem"
      type="DTS:ScriptProjectProjectItemType"
      minOccurs="0" maxOccurs="unbounded"
      form="unqualified"/>
    <xs:element name="BinaryItem"
      type="DTS:ScriptProjectBinaryItemType"
      minOccurs="0" form="unqualified"/>
    <xs:element name="Breakpoint"
      type="DTS:ScriptProjectBreakpointType"
      minOccurs="0" maxOccurs="unbounded"
      form="unqualified"/>
  </xs:sequence>
  <xs:attribute name="Name" type="xs:string" form="unqualified"/>
  <xs:attribute name="VSTAMajorVersion" type="xs:int"
    form="unqualified"/>
  <xs:attribute name="VSTAMinorVersion" type="xs:int"
    form="unqualified"/>
  <xs:attribute name="Language" type="DTS:ScriptProjectLanguageEnum"
    form="unqualified"/>
  <xs:attribute name="EntryPoint" type="xs:string"
    form="unqualified"/>
  <xs:attribute name="ReadOnlyVariables" type="xs:string"
    form="unqualified"/>
  <xs:attribute name="ReadWriteVariables" type="xs:string"
    form="unqualified"/>
</xs:complexType>
```

The following table provides additional information about the elements, types, and constraints in the **ScriptProjectObjectType** complex type.

| Element | Constraints | Type definition | Description |
|--------------------|-------------|--|--|
| ProjectItem | None | ScriptProjectProjectItemType | A string value that specifies the source code for a single item of a development environment project. |
| BinaryItem | None | ScriptProjectBinaryItemType | A base64 binary value that specifies the compiled binary from the development environment of the script project. |
| Breakpoint | None | ScriptProjectBreakpointType | A complex value that specifies a breakpoint in the code. |

The following table specifies the attributes of the **ScriptProjectObjectDataType** type.

| Attribute | Description |
|---------------------------|--|
| Name | A string value that specifies the name of the script project task. |
| VSTAMajorVersion | An integer value that specifies the major version number. <89> |
| VSTAMinorVersion | An integer value that specifies the minor version number. <90> |
| Language | An enumeration value that specifies the language for the script project. |
| EntryPoint | A string value that specifies the name of the entry point routine in the code for the script project. |
| ReadOnlyVariables | A string value that specifies read-only variables in the package file that are available to the code in the script project. |
| ReadWriteVariables | A string value that specifies the read-write variables in the package file that are available to the code in the script project. |

2.7.1.15.1 ScriptProjectProjectItemType

The **ScriptProjectProjectItemType** complex type is used to specify the source code for the Script Task that is executed.

The following is the XSD of the **ScriptProjectProjectItemType** complex type.

```
<xs:complexType name="ScriptProjectProjectItemType">
  <xs:simpleContent>
    <xs:extension base="xs:string">
      <xs:attribute name="Name" type="xs:string"
        form="unqualified"/>
    </xs:extension>
  </xs:simpleContent>
</xs:complexType>
```

The value of element of the **ScriptProjectProjectItemType** complex type is a string that specifies one source code item of the source code for the Script Task that is executed.

The following table specifies additional information for the attributes of the **ScriptProjectProjectItemType** complex type.

| Attribute | Description |
|-------------|--|
| Name | A string value that specifies the name of the source file in the development environment in which the source code was developed. |

2.7.1.15.2 ScriptProjectBinaryItemType

The **ScriptProjectBinaryItemType** complex type contains a representation of the binary of the compiled code for the Script Task.

The following is the XSD of the **ScriptProjectBinaryItemType** complex type.

```
<xs:complexType name="ScriptProjectBinaryItemType">
  <xs:simpleContent>
    <xs:extension base="xs:base64Binary">
      <xs:attribute name="Name" type="xs:string"
        form="unqualified"/>
    </xs:extension>
  </xs:simpleContent>
</xs:complexType>
```

The value of the element of the **ScriptProjectBinaryItemType** complex type is a base64 binary representation that specifies the executable code for the Script Task.

The following table specifies additional information for the attributes of the **ScriptProjectBinaryItemType** complex type.

| Attribute | Description |
|-------------|--|
| Name | A string value that specifies the name of the binary file in the development environment in which the source code was developed. |

2.7.1.15.3 ScriptProjectBreakpointType

The **ScriptProjectBreakpointType** complex type contains a representation of the breakpoints that are set in the development environment for the Script Task.

The following is the XSD of the **ScriptProjectBreakpointType** complex type.

```
<xs:complexType name="ScriptProjectBreakpointType">
  <xs:sequence/>
  <xs:attribute name="Name" type="xs:string" form="unqualified"/>
  <xs:attribute name="Enabled" type="xs:string"
    form="unqualified"/>
  <xs:attribute name="Function" type="xs:string"
    form="unqualified"/>
  <xs:attribute name="File" type="xs:string" form="unqualified"/>
  <xs:attribute name="Line" type="xs:int" form="unqualified"/>
  <xs:attribute name="Column" type="xs:int" form="unqualified"/>
  <xs:attribute name="Condition" type="xs:string"
    form="unqualified"/>
  <xs:attribute name="ConditionType"
    type="DTS:ScriptProjectConditionTypeEnum"
    form="unqualified"/>
  <xs:attribute name="Language" type="xs:string"
    form="unqualified"/>
  <xs:attribute name="HitCount" type="xs:int" form="unqualified"/>
```

```

    <xs:attribute name="HitCountType" form="unqualified"
                type="DTS:ScriptProjectHitCountTypeEnum"/>
</xs:complexType>

```

The following table specifies additional information for the attributes of the **ScriptProjectBinaryItemType** complex type.

| Attribute | Description |
|----------------------|--|
| Name | A string value that specifies the name of the breakpoint. |
| Enabled | An enumeration value that specifies whether the breakpoint is enabled. "True" specifies that the breakpoint is enabled. "False" specifies that the breakpoint is not enabled. |
| Function | A string value that specifies the name of the function in which the breakpoint is set. |
| File | A string value that specifies the name of the file in which the breakpoint is set. |
| Line | An integer value that specifies the line number at which the breakpoint is set. |
| Column | An integer value that specifies the character column at which the breakpoint is set. |
| Condition | A string value that specifies a condition that can be evaluated as a Boolean, to determine whether the breakpoint is fired. Whether the breakpoint is fired depends upon this Condition value and upon the values of the attributes ConditionType , HitCount , and HitType . |
| ConditionType | An enumeration value that specifies when the evaluation of the string in the Condition attribute causes a breakpoint to be fired. |
| Language | A string value that specifies the language of the Script Task. <91> |
| HitCount | An integer value that specifies a criteria for a hit count. This value, along with the value of the HitCountType attribute, is used to determine whether a break point is fired. |
| HitCountType | An enumeration value that specifies the type of hit count condition that causes the breakpoint to be fired. |

2.7.1.15.4 ScriptProjectLanguageEnum

The **ScriptProjectLanguageEnum** type contains the enumeration values for the **Language** attribute.

The following is the XSD of the **ScriptProjectLanguageEnum** type.

```

<xs:simpleType name="ScriptProjectLanguageEnum">
  <xs:restriction base="xs:string">
    <xs:enumeration value="CSharp"/>
    <xs:enumeration value="VisualBasic"/>
  </xs:restriction>
</xs:simpleType>

```

The following table specifies the enumeration values for the **ScriptProjectLanguageEnum** type.

| Enumeration value | Description |
|-------------------|---|
| CSharp | Specifies that the C# language is used. For more information, see [MSDN-C#LS] . |

| Enumeration value | Description |
|--------------------|---|
| VisualBasic | Specifies that the Visual Basic language is used. For more information, see [MSDN-VBLR] . |

2.7.1.15.5 ScriptProjectHitCountTypeEnum

The **ScriptProjectHitCountTypeEnum** type contains the enumeration values for the **HitCountType** attribute.

The following is the XSD of the **ScriptProjectHitCountTypeEnum** type.

```
<xs:simpleType name="ScriptProjectHitCountTypeEnum">
  <xs:restriction base="xs:int">
    <xs:minInclusive value="1"/>
    <xs:maxInclusive value="4"/>
  </xs:restriction>
</xs:simpleType>
```

The following table specifies the enumeration values for the **ScriptProjectLanguageEnum** type.

| Enumeration value | Description |
|-------------------|---|
| 1 | Specifies that there is no hit count. |
| 2 | Specifies that the hit count is equal to the specified condition. |
| 3 | Specifies that the hit count is greater than or equal to the specified condition. |
| 4 | Specifies that there are multiple hit count conditions. |

2.7.1.15.6 ScriptProjectConditionTypeEnum

The **ScriptProjectConditionTypeEnum** type contains the enumeration values for the **ConditionType** attribute.

The following is the XSD of the **ScriptProjectConditionTypeEnum** type.

```
<xs:simpleType name="ScriptProjectConditionTypeEnum">
  <xs:restriction base="xs:int">
    <xs:minInclusive value="1"/>
    <xs:maxInclusive value="2"/>
  </xs:restriction>
</xs:simpleType>
```

The following table specifies the enumeration values for the **ScriptProjectLanguageEnum** type.

| Enumeration value | Description |
|-------------------|----------------------------------|
| 1 | Break when condition is true. |
| 2 | Break when condition is changed. |

2.7.1.16 SendMailTaskData Element

The **SendMailTaskData** element is used to specify parameters, properties, and settings that are specific to the execution of a Send Mail Task. This element resides in the [SendMailTask](#) namespace. The [ExecutableObjectDataType](#) type refers to this element within an XSD **choice** element, using the XSD **ref** attribute, in the following XSD fragment.

```
<xs:element ref="SendMailTask:SendMailTaskData"/>
```

2.7.1.16.1 SendMailTask Namespace

The **SendMailTask** namespace specifies elements and types that are used by the Send Mail Task.

The following is the XSD declaration for the **SendMailTask** namespace.

```
xmlns:SendMailTask="www.microsoft.com/sqlserver/dts/tasks/sendmailtask"
```

2.7.1.16.1.1 SendMailTaskData Element

The following is the XSD for the element declaration for the **SendMailTaskData** element in the [SendMailTask](#) namespace.

```
<xs:element name="SendMailTaskData"  
  type="SendMailTask:SendMailTaskType"/>
```

2.7.1.16.1.1.1 SendMailTaskType

The **SendMailTaskType** complex type holds parameters, properties, and settings for the Send Mail Task.

The following is the XSD for the **SendMailTaskType** complex type.

```
<xs:complexType name="SendMailTaskType">  
  <xs:sequence>  
    <xs:element name="Attachments" minOccurs="0"  
      type="SendMailTask:AttachmentsElementType"/>  
  </xs:sequence>  
  <xs:attribute name="SMTPServer" type="xs:string"/>  
  <xs:attribute name="From" type="xs:string"/>  
  <xs:attribute name="To" type="xs:string"/>  
  <xs:attribute name="CC" type="xs:string"/>  
  <xs:attribute name="BCC" type="xs:string"/>  
  <xs:attribute name="Subject" type="xs:string"/>  
  <xs:attribute name="Priority"  
    type="SendMailTask:SendMailPriorityEnum"/>  
  <xs:attribute name="MessageSourceType"  
    type="DTS:SourceTypeEnum"/>  
  <xs:attribute name="MessageSource" type="xs:string"/>  
</xs:complexType>
```

The following table provides additional information about the elements, types, and constraints for the **SendMailTaskType** complex type.

| Element | Constraints | Type definition | Description |
|--------------------|-------------|--|---|
| Attachments | None | AttachmentsElementType | Contains information about the files to be attached |

| Element | Constraints | Type definition | Description |
|---------|-------------|-----------------|-----------------|
| | | | to the message. |

The following table specifies additional information for the attributes of the **SendMailTaskType** complex type.

| Attribute | Description |
|--------------------------|---|
| SMTPServer | A string value that specifies a reference to a connection manager by its DTSID property value or by its ObjectName property value. |
| From | A string value that specifies the From field of the mail message. |
| To | A string value that specifies the To field of the mail message. |
| CC | A string value that specifies the Cc field of the mail message. |
| BCC | A string value that specifies the Bcc field of the mail message. |
| Subject | A string value that specifies the Subject field of the mail message. |
| Priority | An enumeration value that specifies the priority of the mail message. |
| MessageSourceType | An enumeration value that specifies the source type of the mail message. |
| MessageSource | A string value that specifies the content of the mail message. This value is used only if the MessageSourceType attribute is set to the value "DirectInput". |

2.7.1.16.1.1.1.1 AttachmentsElementType

The **AttachmentsElementType** complex type is used to specify attachments to mail messages that are sent with the Send Mail Task.

The following is the XSD for the **AttachmentsElementType** complex type.

```
<xs:complexType name="AttachmentsElementType">
  <xs:sequence/>
  <xs:attribute name="FileName" type="xs:string"/>
</xs:complexType>
```

The following table specifies additional information for the attributes of the **AttachmentsElementType** complex type.

| Attribute | Description |
|-----------------|---|
| FileName | A string value that specifies the names of the files that are attached to the mail message that is sent by the Send Mail Task. If more than one file is attached, the file names MUST be separated by a vertical bar () character. |

2.7.1.16.1.1.1.2 SendMailPriorityEnum

The **SendMailPriorityEnum** type contains the enumeration values for the **Priority** attribute.

The following is the XSD of the **SendMailPriorityEnum** type.

```

<xs:simpleType name="SendMailPriorityEnum">
  <xs:restriction base="xs:string">
    <xs:enumeration value="High"/>
    <xs:enumeration value="Low"/>
    <xs:enumeration value="Normal"/>
  </xs:restriction>
</xs:simpleType>

```

The following table specifies the enumeration values for the **SendMailPriorityEnum** type.

| Enumeration value | Description |
|-------------------|---|
| High | Specifies that the mail message is marked as high priority. |
| Low | Specifies that the mail message is marked as low priority. |
| Normal | Specifies that the mail message is marked as normal priority. |

2.7.1.17 TransferDatabaseTaskDataObjectType

The **TransferDatabaseTaskDataObjectType** complex type is used to specify parameters, properties, and settings that are specific to the Transfer Database Task.

The following is the XSD for the **TransferDatabaseTaskDataObjectType** complex type.

```

<xs:complexType name="TransferDatabasesTaskDataObjectType">
  <xs:sequence/>
  <xs:attribute name="SrcConn" type="xs:string" form="unqualified"/>
  <xs:attribute name="DestConn" type="xs:string" form="unqualified"/>
  <xs:attribute name="Action" type="DTS:TransferDatabaseTaskActionEnum"
    form="unqualified"/>
  <xs:attribute name="Method" type="DTS:TransferDatabaseTaskMethodEnum"
    form="unqualified"/>
  <xs:attribute name="SrcDBName" type="xs:string" form="unqualified"/>
  <xs:attribute name="ReattachSrcDB" type="xs:boolean"
    form="unqualified"/>
  <xs:attribute name="SrcDBFiles" type="xs:string"
    form="unqualified"/>
  <xs:attribute name="DestDBName" type="xs:string"
    form="unqualified"/>
  <xs:attribute name="DestDBFiles" type="xs:string"
    form="unqualified"/>
  <xs:attribute name="DestOverwrite" type="xs:boolean"
    form="unqualified"/>
</xs:complexType>

```

The **TransferDatabaseTaskDataObjectType** complex type **MUST NOT** contain any elements or values.

The following table specifies the attributes of the **TransferDatabaseTaskDataObjectType** complex type.

| Attribute | Description |
|-----------------|--|
| SrcConn | A string value that specifies a reference to a connection manager by its DTSID property value or by its ObjectName property value. |
| DestConn | A string value that specifies a reference to a connection manager by its DTSID property value |

| Attribute | Description |
|----------------------|--|
| | or by its ObjectName property value. |
| Action | An enumeration value that specifies which transfer action to perform. |
| Method | An enumeration value that specifies the method to use when performing the database transfer. |
| SrcDBName | A string value that specifies the name of the source database. |
| ReattachSrcDB | A Boolean value that specifies whether to attempt to reattach the source database if a failure occurs. TRUE specifies that there MUST be an attempt to reattach the source database if a failure occurs. FALSE specifies that there MUST NOT be an attempt to reattach the source database if a failure occurs. |
| SrcDBFiles | A string value that specifies the name and location of the files at the source database. The string value is a comma-delimited list. |
| DestDBName | A string value that specifies the name of the destination database. |
| DestDBFiles | A string value that specifies the name and location of the files at the destination database. The string value is a comma-delimited list. |
| DestOverwrite | A Boolean value that specifies whether to overwrite a database at the destination if a database of the same name exists at the destination. TRUE specifies that a database of the same name at the destination MUST be overwritten. FALSE specifies that a database of the same name at the destination MUST NOT be overwritten. |

2.7.1.17.1 TransferDatabaseTaskActionEnum

The **TransferDatabaseTaskActionEnum** type contains the enumeration values for the **Action** attribute.

The following is the XSD of the **TransferDatabaseTaskActionEnum** type.

```
<xs:simpleType name="TransferDatabaseTaskActionEnum">
  <xs:restriction base="xs:int">
    <xs:minInclusive value="0"/>
    <xs:maxInclusive value="1"/>
  </xs:restriction>
</xs:simpleType>
```

The following table specifies the enumeration values for the **TransferDatabaseTaskActionEnum** type.

| Enumeration value | Description |
|-------------------|---|
| 0 | The database MUST be transferred by using a copy operation. |
| 1 | The database MUST be transferred by using a move operation. |

2.7.1.17.2 TransferDatabaseTaskMethodEnumType

The **TransferDatabaseTaskMethodEnum** type contains the enumeration values for the **Method** attribute.

The following is the XSD of the **TransferDatabaseTaskActionEnum** type.

```
<xs:simpleType name="TransferDatabaseTaskMethodEnum">
  <xs:restriction base="xs:int">
    <xs:minInclusive value="0"/>
    <xs:maxInclusive value="1"/>
  </xs:restriction>
</xs:simpleType>
```

The following table specifies the enumeration values for the **TransferDatabaseTaskMethodEnum** type.

| Enumeration value | Description |
|-------------------|--|
| 0 | The database MUST be transferred when the database is offline. |
| 1 | The database MUST be transferred when the database is online. |

2.7.1.18 TransferErrorMessagesTaskDataObjectDataType

The **TransferErrorMessagesTaskDataObjectDataType** complex type is used to specify parameters, properties, and settings that are specific to the Transfer Database Task.

The following is the XSD for the **TransferErrorMessagesTaskDataObjectDataType** complex type.

```
<xs:complexType name="TransferErrorMessagesTaskDataObjectDataType">
  <xs:sequence/>
  <xs:attribute name="TransferAllErrorMessages" type="xs:boolean"
    form="unqualified"/>
  <xs:attribute name="ErrorMessagesList" type="xs:string"
    form="unqualified"/>
  <xs:attribute name="ErrorMessageLanguagesList" type="xs:string"
    form="unqualified"/>
  <xs:attribute name="IfObjectExists" type="DTS:IfObjectExistsEnum"
    form="unqualified"/>
  <xs:attribute name="SourceConnection" type="xs:string"
    form="unqualified"/>
  <xs:attribute name="DestinationConnection" type="xs:string"
    form="unqualified"/>
</xs:complexType>
```

The **TransferErrorMessagesTaskDataObjectDataType** complex type MUST NOT contain any elements or values.

The following table specifies the attributes of the **TransferErrorMessagesTaskDataObjectDataType** complex type.

| Attribute | Description |
|---------------------------------|---|
| TransferAllErrorMessages | A Boolean value that specifies whether to transfer all user-defined error messages or only the specified user-defined error messages. TRUE specifies that all user-defined error messages are transferred. FALSE specifies that only the specified user-defined messages are transferred. |

| Attribute | Description |
|----------------------------------|--|
| ErrorMessageList | A string value that specifies a list of the error messages that are transferred. |
| ErrorMessageLanguagesList | A string value that specifies a list of languages for which the error messages are transferred. |
| IfObjectExists | An enumeration value that specifies what action is taken if an error message with the same name already exists at the destination. |
| SourceConnection | A string value that specifies a reference to a connection manager by its DTSID property value or by its ObjectName property value. |
| DestinationConnection | A string value that specifies a reference to a connection manager by its DTSID property value or by its ObjectName property value. |

2.7.1.19 TransferJobsTaskDataObjectDataType

The **TransferJobsTaskDataObjectDataType** complex type is used to specify parameters, properties, and settings that are specific to the Transfer Database Task.

The following is the XSD for the **TransferJobsTaskDataObjectDataType** complex type.

```
<xs:complexType name="TransferJobsTaskDataObjectDataType">
  <xs:sequence/>
  <xs:attribute name="TransferAllJobs" type="xs:boolean"
    form="unqualified"/>
  <xs:attribute name="JobsList" type="xs:string"
    form="unqualified"/>
  <xs:attribute name="IfObjectExists" type="DTS:IfObjectExistsEnum"
    form="unqualified"/>
  <xs:attribute name="EnableJobsAtDestination" type="xs:boolean"
    form="unqualified"/>
  <xs:attribute name="SourceConnection" type="xs:string"
    form="unqualified"/>
  <xs:attribute name="DestinationConnection" type="xs:string"
    form="unqualified"/>
</xs:complexType>
```

The **TransferJobsTaskDataObjectDataType** complex type MUST NOT contain any elements or values.

The following table specifies the attributes of the **TransferJobsTaskDataObjectDataType** complex type.

| Attribute | Description |
|--------------------------------|---|
| TransferAllJobs | A Boolean value that specifies whether to transfer all jobs or only the specified jobs. TRUE specifies that all jobs are transferred. FALSE specifies that only the specified jobs are transferred. |
| JobsList | A string value that specifies a list of jobs that are transferred. |
| IfObjectExists | An enumeration value that specifies what action is taken if a job of the same name already exists at the destination. |
| EnableJobsAtDestination | A Boolean value that specifies whether to enable jobs that are created at the |

| Attribute | Description |
|------------------------------|---|
| | destination. TRUE specifies that jobs that are created at the destination MUST be enabled. FALSE specifies that jobs that are created at the destination MUST NOT be enabled. |
| SourceConnection | A string value that specifies a reference to a connection manager by its DTSID property value or by its ObjectName property value. |
| DestinationConnection | A string value that specifies a reference to a connection manager by its DTSID property value or by its ObjectName property value. |

2.7.1.20 TransferLoginsTaskDataObjectDataType

The **TransferLoginsTaskDataObjectDataType** complex type is used to specify parameters, properties, and settings that are specific to the Transfer Database Task.

The following is the XSD for the **TransferLoginsTaskDataObjectDataType** complex type.

```
<xs:complexType name="TransferLoginsTaskDataObjectDataType">
  <xs:sequence/>
  <xs:attribute name="LoginsToTransfer"
    type="DTS:TransferLoginsTaskLoginsToTransferEnum"
    form="unqualified"/>
  <xs:attribute name="CopySids" type="xs:boolean" form="unqualified"/>
  <xs:attribute name="LoginList" type="xs:string" form="unqualified"/>
  <xs:attribute name="IfObjectExists" type="DTS:IfObjectExistsEnum"
    form="unqualified"/>
  <xs:attribute name="SourceConnection" type="xs:string"
    form="unqualified"/>
  <xs:attribute name="DestinationConnection" type="xs:string"
    form="unqualified"/>
  <xs:attribute name="DatabasesList" type="xs:string"
    form="unqualified"/>
</xs:complexType>
```

The **TransferLoginsTaskDataObjectDataType** complex type MUST NOT contain any elements or values.

The following table specifies the attributes of the **TransferLoginsTaskDataObjectDataType** complex type.

| Attribute | Description |
|-------------------------|---|
| LoginsToTransfer | An enumeration value that specifies which logins MUST be transferred by the task. |
| CopySids | A Boolean value that specifies whether the security identifiers (SIDS) that are associated with logins are also transferred. TRUE specifies that the SIDS MUST be transferred with the logins. FALSE specifies that the SIDS MUST NOT be transferred with the logins. |
| LoginList | A string value that specifies the list of logins to be transferred. |
| IfObjectExists | An enumeration value that specifies what action is taken if a login of the same name already exists at the destination. |
| SourceConnection | A string value that specifies a reference to a connection manager by its DTSID property value or by its ObjectName property value. |

| Attribute | Description |
|------------------------------|--|
| DestinationConnection | A string value that specifies a reference to a connection manager by its DTSID property value or by its ObjectName property value. |
| DatabaseList | A string value that specifies the list of databases that exist on the source connection to transfer. |

2.7.1.20.1 TransferLoginsTaskLoginsToTransferEnum

The **TransferLoginsTaskLoginsToTransferEnum** type contains the enumeration values for the **LoginsToTransfer** attribute.

The following is the XSD of the **TransferLoginsTaskLoginsToTransferEnum** type.

```
<xs:simpleType name="TransferLoginsTaskLoginsToTransferEnum">
  <xs:restriction base="xs:string">
    <xs:enumeration value="SelectedLogins"/>
    <xs:enumeration value="AllLoginsFromSelectedDatabases"/>
    <xs:enumeration value="AllLogins"/>
  </xs:restriction>
</xs:simpleType>
```

The following table specifies the enumeration values for the **TransferLoginsTaskLoginsToTransferEnum** type.

| Enumeration value | Description |
|---------------------------------------|--|
| SelectedLogins | Specifies that the selected logins are transferred. |
| AllLoginsFromSelectedDatabases | Specifies that all logins from the selected databases are transferred. |
| AllLogins | Specifies that all logins are transferred. |

2.7.1.21 TransferStoredProceduresTaskDataObjectDataType

The **TransferStoredProceduresTaskDataObjectDataType** complex type is used to specify parameters, properties, and settings that are specific to the Transfer Database Task.

The following is the XSD for the **TransferStoredProceduresTaskDataObjectDataType** complex type.

```
<xs:complexType name="TransferStoredProceduresTaskDataObjectDataType">
  <xs:sequence/>
  <xs:attribute name="TransferAllStoredProcedures"
    type="xs:boolean" form="unqualified"/>
  <xs:attribute name="StoredProceduresList" type="xs:string"
    form="unqualified"/>
  <xs:attribute name="IfObjectExists" type="DTS:IfObjectExistsEnum"
    form="unqualified"/>
  <xs:attribute name="SourceConnection" type="xs:string"
    form="unqualified"/>
  <xs:attribute name="m DestinationConnectionID"
    type="xs:string" form="unqualified"/>
```

</xs:complexType>

The **TransferStoredProceduresTaskDataObjectDataType** complex type MUST NOT contain any elements or values.

The following table specifies the attributes of the **TransferStoredProceduresTaskDataObjectDataType** complex type.

| Attribute | Description |
|------------------------------------|---|
| TransferAllStoredProcedures | A Boolean value that specifies whether to transfer all user-defined stored procedures in the master database or just the specified stored procedures. TRUE specifies that all user-defined stored procedures in the master database are transferred. FALSE specifies that only the specified stored procedures in the database are transferred. |
| StoredProceduresList | A string value that specifies the list of stored procedures in the master database that are transferred. |
| IfObjectExists | An enumeration value that specifies what action is taken if a stored procedure of the same name already exists at the destination. |
| SourceConnection | A string value that specifies a reference to a connection manager by its DTSID property value or by its ObjectName property value. |
| m_DestinationConnectionID | A string value that specifies a reference to a connection manager by its DTSID property value or by its ObjectName property value. |

2.7.1.22 TransferSqlServerObjectsTaskDataObjectDataType

The **TransferSqlServerObjectsTaskDataObjectDataType** complex type is used to specify parameters, properties, and settings that are specific to the Transfer Database Task.

The following is the XSD for the **TransferSqlServerObjectsTaskDataObjectDataType** complex type.

```
<xs:complexType name="TransferSqlServerObjectsTaskDataObjectDataType">
  <xs:sequence/>
  <xs:attribute name="SourceConnection" type="xs:string"
    form="unqualified"/>
  <xs:attribute name="DestinationConnection" type="xs:string"
    form="unqualified"/>
  <xs:attribute name="SourceDatabase" type="xs:string"
    form="unqualified"/>
  <xs:attribute name="DestinationDatabase" type="xs:string"
    form="unqualified"/>
  <xs:attribute name="CopyAllObjects" type="xs:boolean"
    form="unqualified"/>
  <xs:attribute name="CopyAllRules" type="xs:boolean"
    form="unqualified"/>
  <xs:attribute name="CopyAllTables" type="xs:boolean"
    form="unqualified"/>
  <xs:attribute name="CopyAllViews" type="xs:boolean"
    form="unqualified"/>
  <xs:attribute name="CopyAllStoredProcedures"
    type="xs:boolean" form="unqualified"/>
  <xs:attribute name="CopyAllUserDefinedFunctions"
```

```

        type="xs:boolean" form="unqualified"/>
<xs:attribute name="CopyAllDefaults" type="xs:string"
form="unqualified"/>
<xs:attribute name="CopyAllUserDefinedDataTypes"
type="xs:boolean" form="unqualified"/>
<xs:attribute name="CopyAllPartitionFunctions" type="xs:boolean"
form="unqualified"/>
<xs:attribute name="CopyAllPartitionSchemes" type="xs:boolean"
form="unqualified"/>
<xs:attribute name="CopyAllSchemas" type="xs:boolean"
form="unqualified"/>
<xs:attribute name="CopyAllSqlAssemblies" type="xs:boolean"
form="unqualified"/>
<xs:attribute name="CopyAllUserDefinedAggregates"
type="xs:boolean" form="unqualified"/>
<xs:attribute name="CopyAllUserDefinedTypes" type="xs:boolean"
form="unqualified"/>
<xs:attribute name="CopyAllXmlSchemaCollections" type="xs:boolean"
form="unqualified"/>
<xs:attribute name="LoginsList" type="xs:string"
form="unqualified"/>
<xs:attribute name="UsersList" type="xs:string"
form="unqualified"/>
<xs:attribute name="RulesList" type="xs:string"
form="unqualified"/>
<xs:attribute name="TablesList" type="xs:string"
form="unqualified"/>
<xs:attribute name="ViewsList" type="xs:string"
form="unqualified"/>
<xs:attribute name="StoredProceduresList"
type="xs:string" form="unqualified"/>
<xs:attribute name="UserDefinedFunctionsList"
type="xs:string" form="unqualified"/>
<xs:attribute name="DefaultsList" type="xs:string"
form="unqualified"/>
<xs:attribute name="UserDefinedDataTypesList"
type="xs:string" form="unqualified"/>
<xs:attribute name="PartitionFunctionsList" type="xs:string"
form="unqualified"/>
<xs:attribute name="PartitionSchemesList" type="xs:string"
form="unqualified"/>
<xs:attribute name="SchemasList" type="xs:string"
form="unqualified"/>
<xs:attribute name="SqlAssembliesList" type="xs:string"
form="unqualified"/>
<xs:attribute name="UserDefinedAggregatesList"
type="xs:string" form="unqualified"/>
<xs:attribute name="UserDefinedTypesList" type="xs:string"
form="unqualified"/>
<xs:attribute name="XmlSchemaCollectionsList" type="xs:string"
form="unqualified"/>
<xs:attribute name="DropObjectsFirst" type="xs:boolean"
form="unqualified"/>
<xs:attribute name="IncludeDependentObjects"
type="xs:boolean" form="unqualified"/>
<xs:attribute name="IncludeExtendedProperties" type="xs:boolean"
form="unqualified"/>
<xs:attribute name="CopyData" type="xs:boolean"
form="unqualified"/>
<xs:attribute name="ExistingData"
type="DTS:TransferSqlServerObjectsTaskExistingDataEnum"
form="unqualified"/>
<xs:attribute name="CopySchema" type="xs:boolean"
form="unqualified"/>
<xs:attribute name="UseCollation" type="xs:boolean"
form="unqualified"/>
<xs:attribute name="CopyDatabaseUsers" type="xs:boolean"
form="unqualified"/>

```

```

<xs:attribute name="CopyDatabaseRoles" type="xs:boolean"
  form="unqualified"/>
<xs:attribute name="CopySqlServerLogins" type="xs:boolean"
  form="unqualified"/>
<xs:attribute name="CopyObjectLevelPermissions" type="xs:boolean"
  form="unqualified"/>
<xs:attribute name="CopyIndexes" type="xs:boolean"
  form="unqualified"/>
<xs:attribute name="CopyTriggers" type="xs:boolean"
  form="unqualified"/>
<xs:attribute name="CopyFullTextIndexes" type="xs:boolean"
  form="unqualified"/>
<xs:attribute name="CopyPrimaryKeys" type="xs:boolean"
  form="unqualified"/>
<xs:attribute name="CopyForeignKeys" type="xs:boolean"
  form="unqualified"/>
<xs:attribute name="GenerateScriptsInUnicode" type="xs:boolean"
  form="unqualified"/>
<xs:attribute name="SourceTranslateChar" type="xs:boolean"
  form="unqualified"/>
<xs:attribute name="DestinationTranslateChar" type="xs:boolean"
  form="unqualified"/>
<xs:attribute name="CopyAllDRIObjects" type="xs:boolean"
  form="unqualified"/>
</xs:complexType>

```

The **TransferSqlServerObjectsTaskDataObjectDataType** complex type MUST NOT contain any elements or values.

The following table specifies the attributes of the **TransferSqlServerObjectsTaskDataObjectDataType** complex type.

| Attribute | Description |
|------------------------------|--|
| SourceConnection | A string value that specifies a reference to the connection manager for the source of the data to be transferred. The connection manager can be referenced by its DTSID property or by its ObjectName property. |
| DestinationConnection | A string value that specifies a reference to the connection manager for the destination of the data to be transferred. The connection manager can be referenced by its DTSID property or by its ObjectName property. |
| SourceDatabase | A string value that specifies the source database for objects to be transferred. |
| DestinationDatabase | A string value that specifies the destination database for objects to be transferred. |
| CopyAllObjects | A Boolean value that specifies whether the task copies all objects or only the specified objects. TRUE specifies that all objects from the source database are copied. FALSE specifies that only the specified objects are copied. |
| CopyAllRules | A Boolean value that specifies whether the task copies all rule objects or only the specified rule objects. TRUE specifies that all rule objects from the source database are copied. FALSE specifies that only the rules that are specified in the RulesList attribute are copied. |
| CopyAllTables | A Boolean value that specifies whether the task copies all tables or only the specified tables. TRUE specifies that all tables from the source database are copied. |

| Attribute | Description |
|------------------------------------|--|
| | FALSE specifies that only the tables that are specified in the TablesList attribute are copied. |
| CopyAllViews | A Boolean value that specifies whether the task copies all views or only the specified views. TRUE specifies that all views from the source database are copied. FALSE specifies that only the views that are specified in the ViewsList attribute are copied. |
| CopyAllStoredProcedures | A Boolean value that specifies whether the task copies all stored procedures or only the specified stored procedures. TRUE specifies that all stored procedures from the source database are copied. FALSE specifies that only the stored procedures specified in the StoredProceduresList attribute are copied. |
| CopyAllUserDefinedFunctions | A Boolean value that specifies whether the task copies all user-defined functions or only the specified user-defined functions. TRUE specifies that all user-defined functions from the source database are copied. FALSE specifies that only the user-defined functions that are specified in the UserDefinedFunctionsList attribute are copied. |
| CopyAllDefaults | A Boolean value that specifies whether the task copies all defaults or only the specified defaults. TRUE specifies that all defaults from the source database are copied. FALSE specifies that only the defaults specified in the DefaultsList attribute are copied. |
| CopyAllUserDefinedDataTypes | A Boolean value that specifies whether the task copies all user-defined data types or only the specified user-defined data types. TRUE specifies that all user-defined data types from the source database are copied. FALSE specifies that only the user-defined data types specified in the UserDefinedTypesList attribute are copied. |
| CopyAllPartitionFunctions | A Boolean value that specifies whether the task copies all partition functions or only the specified partition functions. TRUE specifies that all partition functions from the source database are copied. FALSE specifies that only the defaults specified in the PartitionFunctionsList attribute are copied. |
| CopyAllPartitionSchemas | A Boolean value that specifies whether the task copies all partition schemas or only the specified partition schemas. TRUE specifies that all partition schemas from the source database are copied. FALSE specifies that only the partition schemas specified in the PartitionSchemeList attribute are copied. |
| CopyAllSchemas | A Boolean value that specifies whether the task copies all schemas or only the specified schemas. TRUE specifies that all schemas from the source database are copied. FALSE specifies that only the schemas specified in the SchemasList attribute are copied. |
| CopyAllSqlAssemblies | A Boolean value that specifies whether the task copies all SQL assemblies or only the specified SQL assemblies. |

| Attribute | Description |
|-------------------------------------|--|
| | TRUE specifies that all SQL assemblies from the source database are copied. FALSE specifies that only the SQL assemblies specified in the SqlAssembliesList attribute are copied. |
| CopyAllUserDefinedAggregates | A Boolean value that specifies whether the task copies all user-defined aggregates or only the specified user-defined aggregates. TRUE specifies that all user-defined aggregates from the source database are copied. FALSE specifies that only the user-defined aggregates specified in the UserDefinedAggregatesList attribute are copied. |
| CopyAllUserDefinedTypes | A Boolean value that specifies whether the task copies all user-defined types or only the specified user-defined types. TRUE specifies that all user-defined types from the source database are copied. FALSE specifies that only the user-defined types that are specified in the UserDefinedTypesList attribute are copied. |
| CopyAllXmlSchemaCollections | A Boolean value that specifies whether the task copies all XML schema collections or only the specified XML schema collections. TRUE specifies that all XML schema collections from the source database are copied. FALSE specifies that only the XML schema collections that are specified in the XmlSchemaCollectionsList attribute are copied. |
| LoginsList | A string value that specifies the list of logins to copy. |
| UsersList | A string value that specifies the list of database users to copy. |
| RulesList | A string value that specifies the list of rules to copy. |
| TablesList | A string value that specifies the list of tables to copy. |
| ViewsList | A string value that specifies the list of views to copy. |
| StoredProceduresList | A string value that specifies the list of stored procedures to copy. |
| UserDefinedFunctionsList | A string value that specifies the list of user-defined functions to copy. |
| DefaultsList | A string value that specifies the list of defaults to copy. |
| UserDefinedDataTypesList | A string value that specifies the list of user-defined data types to copy. |
| PartitionFunctionsList | A string value that specifies the list of partition functions to copy. |
| PartitionSchemesList | A string value that specifies the list of partition schemas to copy. |
| SchemasList | A string value that specifies the list of schemas to copy. |
| SqlAssembliesList | A string value that specifies the list of SQL assemblies to copy. |
| UserDefinedAggregatesList | A string value that specifies the list of user-defined aggregates to copy. |
| UserDefinedTypesList | A string value that specifies the list of user-defined types to copy. |
| XmlSchemaCollectionsList | A string value that specifies the list of XML schema collections to copy. |
| DropObjectsFirst | A Boolean value that specifies whether to drop object on the destination database before the transfer. This option is used only if the value of the CopySchema attribute is set to TRUE. TRUE specifies that objects on the destination server are dropped before the |

| Attribute | Description |
|-----------------------------------|--|
| | transfer. FALSE specifies that objects on the destination server are not dropped before the transfer. |
| IncludeDependentObjects | A Boolean value that specifies whether dependent objects are included with the transfer. TRUE specifies that dependent objects are included with the transfer. FALSE specifies that dependent objects are not included with the transfer. |
| IncludeExtendedProperties | A Boolean value that specifies whether extended properties are included with the transfer. TRUE specifies that extended properties are included with the transfer. FALSE specifies that extended properties are not included with the transfer. |
| CopyData | A Boolean value that specifies whether data is included with the transfer. TRUE specifies that data is included with the transfer. FALSE specifies that data is not included with the transfer. |
| ExistingData | An enumeration value that specifies whether to append or replace existing data. This value is used only if the CopyData attribute is set to TRUE and the DropObjectsFirst attribute is set to FALSE. |
| CopySchema | A Boolean value that specifies whether the schema is included with the transfer. TRUE specifies that the schema is included with the transfer. FALSE specifies that the schema is not included with the transfer. |
| UseCollation | A Boolean value that specifies whether the transfer includes a collation. TRUE specifies that a collation is included with the transfer. FALSE specifies that a collation is not included with the transfer. |
| CopyDatabaseUsers | A Boolean value that specifies whether database users are included in the transfer. TRUE specifies that database users are included with the transfer. The database users that are specified in the UsersList attribute are copied. FALSE specifies that database users are not included with the transfer. |
| CopyDatabaseRoles | A Boolean value that specifies whether database roles are included in the transfer. TRUE specifies that database roles are included with the transfer. FALSE specifies that database roles are not included with the transfer. |
| CopySqlServerLogins | A Boolean value that specifies whether database logins <92> are included in the transfer. TRUE specifies that database logins are included with the transfer. FALSE specifies that database logins are not included with the transfer. |
| CopyObjectLevelPermissions | A Boolean value that specifies whether object-level permissions are included in the transfer. TRUE specifies that object-level permissions are included with the transfer. FALSE specifies that object level permissions are not included with the transfer. |
| CopyIndexes | A Boolean value that specifies whether indexes are included in the transfer. TRUE specifies that indexes are included in the transfer. FALSE specifies that indexes are not included in the transfer. |

| Attribute | Description |
|---------------------------------|--|
| CopyTriggers | A Boolean value that specifies whether triggers are included in the transfer. TRUE specifies that triggers are included in the transfer. FALSE specifies that triggers are not included in the transfer. |
| CopyFullTextIndexes | A Boolean value that specifies whether indexes are included in the transfer. TRUE specifies that triggers are included in the transfer. FALSE specifies that triggers are not included in the transfer. |
| CopyPrimaryKeys | A Boolean value that specifies whether primary key constraints are included in the transfer. TRUE specifies that primary key constraints are included in the transfer. FALSE specifies that primary key constraints are not included in the transfer. |
| CopyForeignKeys | A Boolean value that specifies whether foreign key constraints are included in the transfer. TRUE specifies that foreign key constraints are included in the transfer. FALSE specifies that foreign key constraints are not included in the transfer. |
| GenerateScriptsInUnicode | A Boolean value that specifies whether the script MUST be generated in Unicode format. TRUE specifies that the script MUST be generated in Unicode format. FALSE specifies that the script MUST NOT be generated in Unicode format. |
| SourceTranslateChar | A Boolean value that specifies whether the transfer operation translates the codepage for characters on the source database. TRUE specifies that the transfer operation translates the codepage for characters on the source database. FALSE specifies that the transfer operation does not translate the codepage for characters on the source database. |
| DestinationTranslateChar | A Boolean value that specifies whether the transfer operation translates the codepage for characters on the destination database. TRUE specifies that the transfer operation translates the codepage for characters on the destination database. FALSE specifies that the transfer operation does not translate the codepage for characters on the destination database. |
| CopyAllDRIObjects | A Boolean value that specifies data referential integrity (DRI) objects are included in the transfer. TRUE specifies that DRI objects are included in the transfer. FALSE specifies that DRI objects are not included in the transfer. |

2.7.1.22.1 TransferSqlServerObjectsTaskExistingDataEnum

The **TransferSqlServerObjectsTaskExistingDataEnum** type contains the enumeration values for the **LoginsToTransfer** attribute.

The following is the XSD of the **TransferSqlServerObjectsTaskExistingDataEnum** type.

```
<xs:simpleType name="TransferSqlServerObjectsTaskExistingDataEnum">
  <xs:restriction base="xs:string">
    <xs:enumeration value="Replace"/>
    <xs:enumeration value="Append"/>
  </xs:restriction>
</xs:simpleType>
```



```
</xs:simpleType>
```

The following table specifies the enumeration values for the **TransferSqlServerObjectsTaskExistingDataEnum** type.

| Enumeration value | Description |
|-------------------|---|
| Replace | Specifies that new data replaces existing data. |
| Append | Specifies that new data is appended to existing data. |

2.7.1.23 WebServiceTaskData

The **WebServiceTaskData** element is used to specify parameters, properties, and settings that are specific to the execution of a Web Service Task. This element resides in the [WebServiceTask](#) namespace. The [ExecutableObjectDataType](#) type refers to this element within an XSD **choice** element, using the XSD **ref** attribute, in the following XSD fragment.

```
<xs:element ref="WSTask:WebServiceTaskData"/>
```

2.7.1.23.1 WebServiceTask

The **WebServiceTask** namespace specifies the elements and types that are used by the Web Service Task.

The following is the XSD declaration for the **WebServiceTask** namespace.

```
xmlns:WSTask="www.microsoft.com/sqlserver/dts/tasks/webservicetask"
```

2.7.1.23.1.1 WebServiceTaskData

The following is the XSD for the element declaration for the **WebServiceTaskData** element in the **WebServiceTask** namespace.

```
<xs:element name="WebServiceTaskData"  
  type="WSTask:WSTaskDataType"/>
```

2.7.1.23.1.1.1 WSTaskDataType

The **WSTaskDataType** complex type holds parameters, properties, and settings for the Web Service Task.

The following is the XSD for the **WSTaskDataType** complex type.

```
<xs:complexType name="WSTaskDataType">  
  <xs:sequence>  
    <xs:element name="MethodInfo"  
      type="WSTask:WebServiceTaskDataMethodInfoType"/>  
  </xs:sequence>  
  <xs:attribute name="ConnectionName" type="xs:string"/>  
  <xs:attribute name="Service" type="xs:string"/>  
</xs:complexType>
```

```

<xs:attribute name="WSDLFile" type="xs:string"/>
<xs:attribute name="OverwriteWSDLFile">
  <xs:simpleType>
    <xs:restriction base="xs:string">
      <xs:enumeration value="True"/>
      <xs:enumeration value="False"/>
    </xs:restriction>
  </xs:simpleType>
</xs:attribute>
<xs:attribute name="OutputType"
  type="WSTask:WebServiceTaskDataOutputTypeEnum"/>
<xs:attribute name="OutputLocation" type="xs:string"/>
</xs:complexType>

```

The following table provides additional information about the elements and types for the **WSTaskDataType** complex type.

| Element | Type definition | Description |
|-------------------|--|--|
| MethodInfo | WebServiceTaskDataMethodInfoType | A complex type that specifies the method that is executed by the Web Service Task. |

The following table specifies the attributes of the **WSTaskDataType** complex type.

| Attribute | Description |
|--------------------------|--|
| ConnectionName | A string value that specifies the name of the connection that is used to execute the Web Service Task. |
| Service | A string value that specifies the service name of the web service to be executed. |
| WSDLFile | A string value that specifies the name of the file that contains the Web Services Description Language (WSDL) file that is used with the web service. |
| OverwriteWSDLFile | An enumeration value that specifies whether to overwrite the WSDL file. "True" specifies that the WSDL file MUST be overwritten. "False" specifies that the WSDL file MUST NOT be overwritten. |
| OutputType | An enumeration value that specifies the destination for the output. |
| OutputLocation | A string value that specifies the output location. Depending on the value of the OutputType attribute, this string value contains either a variable name or a file connection reference. |

2.7.1.23.1.1.1.1 **WebServiceTaskDataMethodInfoType**

The **WebServiceTaskDataMethodInfoType** complex type is used to specify information about the method that is called by the Web Service Task.

The following is the XSD for the **WebServiceTaskDataMethodInfoType** complex type.

```

<xs:complexType name="WebServiceTaskDataMethodInfoType">
  <xs:sequence>
    <xs:element name="Documentation" type="xs:string"
      minOccurs="0" maxOccurs="1"/>
    <xs:element name="ParamInfo"
      type="WSTask:WebServiceTaskDataParamInfoType"
      maxOccurs="unbounded"/>
  </xs:sequence>
</xs:complexType>

```

```

</xs:sequence>
<xs:attribute name="MethodName" type="xs:string"/>
<xs:attribute name="MessageName" type="xs:string"/>
</xs:complexType>

```

The following table provides additional information about the elements and types for the **WebServiceTaskDataMethodInfoType** complex type.

| Element | Type definition | Description |
|----------------------|---|--|
| Documentation | xs:string | A string value that contains descriptive documentation for the MethodInfo element contents. |
| ParamInfo | WebServiceTaskDataParamInfoType | A complex type that contains information about the parameters that the called method uses. |

The following table specifies additional information for the attributes of the **WebServiceTaskDataMethodInfoType** complex type.

| Attribute | Description |
|--------------------|--|
| MethodName | A string value that specifies the name of the method that is executed by the Web Service Task. |
| MessageName | A string value that specifies the name of the message that the web service is accessing. |

2.7.1.23.1.1.1.2 WebServiceTaskDataParamInfoType

The **WebServiceTaskDataParamInfoType** complex type is used to specify information about the method that is called by the Web Service Task.

The following is the XSD for the **WebServiceTaskDataParamInfoType** complex type.

```

<xs:complexType name="WebServiceTaskDataParamInfoType">
  <xs:sequence>
    <xs:element name="VariableValue" type="xs:string"
      minOccurs="0" maxOccurs="1"/>
    <xs:element name="PrimitiveValue" type="xs:anySimpleType"
      minOccurs="0" maxOccurs="1"/>
  </xs:sequence>
  <xs:attribute name="Name" type="xs:string"/>
  <xs:attribute name="Datatype" type="xs:string"/>
  <xs:attribute name="ParamType" type="WSTask:ParamTypeEnum"/>
  <xs:attribute name="SeqNumber" type="xs:int"/>
</xs:complexType>

```

The following table provides additional information about the elements and types for the **WebServiceTaskDataParamInfoType** complex type.

| Element | Type definition | Description |
|-----------------------|------------------|---|
| VariableValue | xs:string | A string value that specifies the name of the variable that supplies the value of the parameter. This element appears only if the value of the ParamType attribute is equal to "Variable". |
| PrimitiveValue | xs:anySimpleType | A value of anySimpleType that contains the value of the parameter. This element appears only if the value of the ParamType attribute is equal to "Primitive". |

The following table specifies additional information for the attributes of the **WebServiceTaskDataParamInfoType** complex type.

| Attribute | Description |
|------------------|---|
| Name | A string value that specifies the name of the parameter. |
| Datatype | A string value that specifies the data type of the parameter. The strings that can be used for the value of the Datatype attribute are defined in the WSDL file of the web service that is being called. |
| ParamType | An enumeration value that specifies the type of the parameter. |
| SeqNumber | An integer value that specifies the sequence number of the parameter. |

2.7.1.23.1.1.1.3 WebServiceTaskDataOutputTypeEnum

The **WebServiceTaskDataOutputTypeEnum** type contains the enumeration values for the **OutputType** attribute.

The following is the XSD of the **WebServiceTaskDataOutputTypeEnum** type.

```
<xs:simpleType name="WebServiceTaskDataOutputTypeEnum">
  <xs:restriction base="xs:string">
    <xs:enumeration value="File"/>
    <xs:enumeration value="Variable"/>
  </xs:restriction>
</xs:simpleType>
```

The following table specifies the enumeration values for the **WebServiceTaskDataOutputTypeEnum** type.

| Enumeration value | Description |
|-------------------|--|
| File | Specifies that the output is directed to a file. |
| Variable | Specifies that the output is directed to a variable. |

2.7.1.24 WMIDRTaskDataObjectDataType

The **WMIDRTaskDataObjectDataType** complex type is used to specify parameters, properties, and settings that are specific to the WMI Data Reader Task.

The following is the XSD for the **WMIDRTaskDataObjectDataType** complex type.

```
<xs:complexType name="WMIDRTaskDataObjectDataType">
  <xs:sequence/>
  <xs:attribute name="WQLQuerySourceType" type="DTS:SourceTypeEnum"
    form="unqualified"/>
  <xs:attribute name="WQLQuerySource" type="xs:string"
    form="unqualified"/>
  <xs:attribute name="DestinationType"
    type="DTS:DestinationTypeEnum" form="unqualified"/>
  <xs:attribute name="Destination" type="xs:string"
    form="unqualified"/>
</xs:complexType>
```

```

<xs:attribute name="OverwriteDestination"
              type="DTS:WMITaskDataOverwriteDestinationEnum"
              form="unqualified"/>
<xs:attribute name="OutputType"
              type="DTS:WMITaskDataOutputTypeEnum"
              form="unqualified"/>
<xs:attribute name="WMIConnectionName" type="xs:string"
              form="unqualified"/>
</xs:complexType>

```

The **WMIDRTaskDataObjectDataType** complex type MUST NOT contain any elements or values.

The following table specifies the attributes of the **WMIDRTaskDataObjectDataType** complex type.

| Attribute | Description |
|-----------------------------|--|
| WQLQuerySourceType | An enumeration value that specifies where the source of the WMI Query Language (WQL) is found. |
| WQLQuerySource | A string value that specifies the source of the WQL query. This value is used only if the WQLQuerySourceType value is set to "DirectInput". |
| DestinationType | An enumeration value that specifies the type of the destination where results are sent. |
| Destination | A string value that specifies the destination where results are sent. This attribute contains a variable name or a connection manager reference, depending on the value of the DestinationType attribute. |
| OverwriteDestination | An enumeration value that specifies how output that already exists at the destination is handled. |
| OutputType | An enumeration value that specifies the type of values that are output and the way in which the output values are formatted. |
| WMIConnectionName | A string value that specifies the connection name. The connection name is a reference to a connection manager; the connection name can match either the DTSID property of the connection manager or the ObjectName property of the connection manager. |

2.7.1.24.1 WMITaskDataOverwriteDestinationEnum

The **WMITaskDataOverwriteDestinationEnum** type contains the enumeration values for the **OverwriteDestination** attribute.

The following is the XSD of the **WMITaskDataOverwriteDestinationEnum** type.

```

<xs:simpleType name="WMITaskDataOverwriteDestinationEnum">
  <xs:restriction base="xs:string">
    <xs:enumeration value="KeepOriginal"/>
    <xs:enumeration value="AppendToDestination"/>
    <xs:enumeration value="OverwriteDestination"/>
  </xs:restriction>
</xs:simpleType>

```

The following table specifies the enumeration values for the **WMITaskDataOverwriteDestinationEnum** type.

| Enumeration value | Description |
|-----------------------------|--|
| KeepOriginal | Specifies that the original data is kept and that no data is overwritten. |
| AppendToDestination | Specifies that new data from this task is appended to any existing data at the destination. |
| OverwriteDestination | Specifies that any existing destination data is overwritten with new data from the results of this task. |

2.7.1.24.2 WMITaskDataOutputTypeEnum

The **WMITaskDataOutputTypeEnum** type contains the enumeration values for the **OutputType** attribute.

The following is the XSD of the **WMITaskDataOutputTypeEnum** type.

```
<xs:simpleType name="WMITaskDataOutputTypeEnum">
  <xs:restriction base="xs:string">
    <xs:enumeration value="DataTable"/>
    <xs:enumeration value="PropertyNameAndValue"/>
    <xs:enumeration value="PropertyValue"/>
  </xs:restriction>
</xs:simpleType>
```

The following table specifies the enumeration values for the **WMITaskDataOutputTypeEnum** type.

| Enumeration value | Description |
|-----------------------------|---|
| DataTable | Specifies that the output is formatted as a data table. |
| PropertyNameAndValue | Specifies that the output is in the form of property name/property value pairs, with one pair on each line. |
| PropertyValue | Specifies that only property values are output, one per line. |

2.7.1.25 WMIEWTaskDataObjectDataType

The **WMIEWTaskDataObjectDataType** complex type is used to specify parameters, properties, and settings that are specific to the WMI Event Watcher Task.

The following is the XSD for the **WMIEWTaskDataObjectDataType** complex type.

```
<xs:complexType name="WMIEWTaskDataObjectDataType">
  <xs:sequence/>
  <xs:attribute name="WMIConnectionName" type="xs:string"
    form="unqualified"/>
  <xs:attribute name="WQLQuerySourceType" type="DTS:SourceTypeEnum"
    form="unqualified"/>
  <xs:attribute name="WQLQuerySource" type="xs:string"
    form="unqualified"/>
  <xs:attribute name="ActionAtEvent"
    type="DTS:WMIEWTaskDataActionAtEventEnum"
    form="unqualified"/>
  <xs:attribute name="AfterEvent"
    type="DTS:WMIEWTaskDataAfterEventEnum"/>
</xs:complexType>
```

```

        form="unqualified"/>
<xs:attribute name="ActionAtTimeout"
    type="DTS:WMI EWTaskDataActionAtTimeoutEnum"
    form="unqualified"/>
<xs:attribute name="AfterTimeout"
    type="DTS:WMI EWTaskDataAfterEventEnum"
    form="unqualified"/>
<xs:attribute name="NumberOfEvents" type="xs:int"
    form="unqualified"/>
<xs:attribute name="Timeout" type="xs:int" form="unqualified"/>
</xs:complexType>

```

The **WMI EWTaskDataObjectDataType** complex type MUST NOT contain any elements or values.

The following table specifies the attributes of the **WMI EWTaskDataObjectDataType** complex type.

| Attribute | Description |
|---------------------------|---|
| WMIConnectionName | A string value that specifies the connection name. The WMIConnectionName value is a reference to a connection manager; the connection name can match either the DTSID property of the connection manager or the ObjectName property of the connection manager. |
| WQLQuerySourceType | An enumeration value that specifies where the source for the WQL query is found. |
| WQLQuerySource | A string value that specifies the source of the WQL query. This value is used only if the WQLQuerySourceType value is set to "DirectInput". |
| ActionAtEvent | An enumeration value that specifies the action to take when the event occurs. |
| AfterEvent | An enumeration value that specifies the action to take after the event occurs. |
| ActionAtTimeout | An enumeration value that specifies the action to take when timeout occurs. |
| AfterTimeout | An enumeration value that specifies the action to take after timeout occurs. |
| NumberOfEvents | An integer value that specifies the number of events that the task watches. |
| Timeout | An integer value that specifies the timeout interval for the task, in seconds. |

2.7.1.25.1 WMI EWTaskDataActionAtEventEnum

The **WMI EWTaskDataActionAtEventEnum** type contains the enumeration values for the **ActionAtEvent** attribute and the **ActionAtTimeout** attribute.

The following is the XSD of the **WMI EWTaskDataActionAtEventEnum** type.

```

<xs:simpleType name="WMI EWTaskDataActionAtEventEnum">
  <xs:restriction base="xs:string">
    <xs:enumeration value="LogTheEventAndFireDTSEvent"/>
    <xs:enumeration value="LogTheEvent"/>
  </xs:restriction>
</xs:simpleType>

```

The following table specifies the enumeration values for the **WMI EWTaskDataActionAtEventEnum** type.

| Enumeration value | Description |
|-----------------------------------|--|
| LogTheEventAndFireDTSEvent | Specifies that the event is logged and a DTS event is fired. |
| LogTheEvent | Specifies that the event is only logged. |

2.7.1.25.2 WMIEWTaskDataAfterEventEnum

The **WMIEWTaskDataAfterEventEnum** type contains the enumeration values for the **ActionAfterEvent** attribute.

The following is the XSD of the **WMIEWTaskDataAfterEventEnum** type.

```
<xs:simpleType name="WMIEWTaskDataAfterEventEnum">
  <xs:restriction base="xs:string">
    <xs:enumeration value="WatchfortheEventAgain"/>
    <xs:enumeration value="ReturnWithSuccess"/>
    <xs:enumeration value="ReturnWithFailure"/>
  </xs:restriction>
</xs:simpleType>
```

The following table specifies the enumeration values for the **WMIEWTaskDataAfterEventEnum** type.

| Enumeration value | Description |
|------------------------------|--|
| WatchfortheEventAgain | Specifies that the event is watched for again. |
| ReturnWithSuccess | Specifies that a success exit value is returned. |
| ReturnWithFailure | Specifies that a failure exit value is returned. |

2.7.1.25.3 WMIEWTaskDataActionAtTimeoutEnum

The **WMIEWTaskDataActionAtTimeoutEnum** type contains the enumeration values for the **ActionAtTimeout** attribute.

The following is the XSD of the **WMIEWTaskDataActionAtTimeoutEnum** type.

```
<xs:simpleType name="WMIEWTaskDataActionAtTimeoutEnum">
  <xs:restriction base="xs:string">
    <xs:enumeration value="LogTimeoutAndFireDTSEvent"/>
    <xs:enumeration value="LogTimeout"/>
  </xs:restriction>
</xs:simpleType>
```

The following table specifies the enumeration values for the **WMIEWTaskDataActionAtTimeoutEnum** type.

| Enumeration value | Description |
|----------------------------------|--|
| LogTimeoutAndFireDTSEvent | Specifies that a timeout event is logged and a DTS event is fired. |
| LogTimeout | Specifies that a timeout event is logged only. |

2.7.1.26 XMLTaskDataObjectDataType

The **XMLTaskDataObjectDataType** complex type is used to specify parameters, properties, and settings that are specific to the XML Task.

The following is the XSD for the **XMLTaskDataObjectDataType** complex type.

```
<xs:complexType name="XMLTaskDataObjectDataType">
  <xs:sequence>
  </xs:sequence>
  <xs:attribute name="OperationType" form="unqualified"
    type="DTS:XMLTaskOperationTypeEnum"/>
  <xs:attribute name="SourceType" type="DTS:SourceTypeEnum"
    form="unqualified"/>
  <xs:attribute name="Source" type="xs:string" form="unqualified"/>
  <xs:attribute name="SecondOperandType" type="DTS:SourceTypeEnum"
    form="unqualified"/>
  <xs:attribute name="SecondOperand" type="xs:string"
    form="unqualified"/>
  <xs:attribute name="SaveOperationResult" form="unqualified">
    <xs:simpleType>
      <xs:restriction base="xs:string">
        <xs:enumeration value="True"/>
        <xs:enumeration value="False"/>
      </xs:restriction>
    </xs:simpleType>
  </xs:attribute>
  <xs:attribute name="DestinationType"
    type="DTS:DestinationTypeEnum" form="unqualified"/>
  <xs:attribute name="Destination" type="xs:string"
    form="unqualified"/>
  <xs:attribute name="OverwriteDestination" form="unqualified">
    <xs:simpleType>
      <xs:restriction base="xs:string">
        <xs:enumeration value="True"/>
        <xs:enumeration value="False"/>
      </xs:restriction>
    </xs:simpleType>
  </xs:attribute>
  <xs:attribute name="FailOpOnValidationFail" form="unqualified">
    <xs:simpleType>
      <xs:restriction base="xs:string">
        <xs:enumeration value="True"/>
        <xs:enumeration value="False"/>
      </xs:restriction>
    </xs:simpleType>
  </xs:attribute>
  <xs:attribute name="FailOpOnDifference" form="unqualified">
    <xs:simpleType>
      <xs:restriction base="xs:string">
        <xs:enumeration value="True"/>
        <xs:enumeration value="False"/>
      </xs:restriction>
    </xs:simpleType>
  </xs:attribute>
  <xs:attribute name="SaveDiffGram" form="unqualified">
    <xs:simpleType>
      <xs:restriction base="xs:string">
        <xs:enumeration value="True"/>
        <xs:enumeration value="False"/>
      </xs:restriction>
    </xs:simpleType>
  </xs:attribute>
  <xs:attribute name="DiffGramDestinationType" form="unqualified"
    type="DTS:DestinationTypeEnum" />

```

```

<xs:attribute name="DiffGramDestination" form="unqualified"
  type="xs:string" />
<xs:attribute name="DiffOptions" type="DTS:XMLTaskDiffOptionsType"
  form="unqualified"/>
<xs:attribute name="DiffAlgorithm" form="unqualified"
  type="DTS:XMLTaskDiffAlgorithmEnum" />
<xs:attribute name="XPathStringSourceType"
  type="DTS:SourceTypeEnum" form="unqualified"/>
<xs:attribute name="XPathStringSource" type="xs:string"
  form="unqualified"/>
<xs:attribute name="XPathOperation" form="unqualified"
  type="DTS:XMLTaskXPathOperationEnum" />
<xs:attribute name="PutResultInOneNode" form="unqualified">
  <xs:simpleType>
    <xs:restriction base="xs:string">
      <xs:enumeration value="True"/>
      <xs:enumeration value="False"/>
    </xs:restriction>
  </xs:simpleType>
</xs:attribute>
<xs:attribute name="ValidationType"
  type="DTS:XMLTaskValidationTypeEnum"
  form="unqualified"/>
</xs:complexType>

```

The **XMLTaskDataObjectDataType** complex type MUST NOT contain any elements or values.

The following table specifies the attributes of the **XMLTaskDataObjectDataType** complex type.

| Attribute | Description |
|-------------------------------|---|
| OperationType | An enumeration value that specifies the type of operation that is performed by the XML Task. |
| SourceType | An enumeration value that specifies the source type for the XML document that is used by the XML Task. |
| Source | A string value that contains the source. The content of the string depends on the value of the SourceType attribute. |
| SecondOperandType | An enumeration value that selects the source type of the second document that is used by the XML Task. |
| SecondOperand | A string value that contains the source for the second operation. The content of the string depends on the value of the SecondOperandType attribute. |
| SaveOperationResult | An enumeration value that specifies whether to save the result of the operation. "True" specifies that the result of the operation is saved. "False" specifies that the result of the operation is not saved. |
| DestinationType | An enumeration value that specifies the type of the destination. |
| Destination | A string value that specifies the destination. The content of the string depends on the value of the DestinationType attribute. |
| OverwriteDestination | An enumeration value that specifies whether to overwrite any content that already exists at the destination. "True" specifies that the existing content at the destination is overwritten. "False" specifies that existing content at the destination is not overwritten. |
| FailOpOnValidationFail | An enumeration value that specifies whether the operation fails if the document fails to validate. "True" specifies that the operation fails if the document fails to validate. |

| Attribute | Description |
|--------------------------------|---|
| | "False" specifies that the operation does not necessarily fail if the document fails to validate. |
| FailOpOnDifference | An enumeration value that specifies whether the operation fails if there is a difference detected. "True" specifies that the operation fails if there is a difference. "False" specifies that the operation does not necessarily fail if there is a difference. |
| SaveDiffGram | An enumeration value that specifies whether to save the result of a Diff operation as a DiffGram document. "True" specifies that the result can be saved as a DiffGram document. "False" specifies that the result is not saved. |
| DiffGramDestinationType | An enumeration value that specifies the type of the destination of the DiffGram output. |
| DiffGramDestination | A string value that specifies the destination of the DiffGram output. The content of the string varies with the value of the DiffGramDestinationType attribute value. |
| DiffOptions | An integer value that specifies the options to be used in the Diff operation. This integer is a bitmask value. |
| DiffAlgorithm | An enumeration value that specifies the algorithm to use for the Diff operation. |
| XPathStringSourceType | An enumeration value that specifies the type of the source of the XPATH string. |
| XPathStringSource | A string value that specifies the XPATH string source. The content of the string depends on the value of the XPathStringSourceType attribute. |
| XPathOperation | An enumeration value that specifies the type of XPATH operation to perform. |
| PutResultInOneNode | An enumeration value that specifies whether to put the output result in one XML node. "True" specifies that the output result is put in one node. "False" specifies that the output result does not need to be put in one node. |
| ValidationType | An enumeration value that specifies the type of validation to perform. |

2.7.1.26.1 XMLTaskOperationTypeEnum

The **XMLTaskOperationTypeEnum** type contains the enumeration values for the **OperationType** attribute.

The following is the XSD of the **XMLTaskOperationTypeEnum** type.

```
<xs:simpleType name="XMLTaskOperationTypeEnum">
  <xs:restriction base="xs:string">
    <xs:enumeration value="Diff"/>
    <xs:enumeration value="Validate"/>
    <xs:enumeration value="Merge"/>
    <xs:enumeration value="XSLT"/>
    <xs:enumeration value="XPATH"/>
    <xs:enumeration value="Patch"/>
  </xs:restriction>
</xs:simpleType>
```

The following table specifies the enumeration values for the **XMLTaskOperationTypeEnum** type.

| Enumeration value | Description |
|-------------------|---|
| Diff | Specifies that two XML documents are compared. |
| Validate | Specifies that the XML is validated against an XSD or a DTD. |
| Merge | Specifies that two XML documents are merged. |
| XSLT | Specifies that an XSLT transformation is run on an XML document. |
| XPATH | Specifies that XPATH queries and evaluations are performed. |
| Patch | Specifies that the output of a diff operation is applied to an XML document to create a new document. |

2.7.1.26.2 XMLTaskDiffOptionsType

The **XMLTaskDiffOptionsType** type is the type of the value that is used for the **DiffOptions** attribute. The **XMLTaskDiffOptionsType** type is a bitmask.

The following is the XSD of the **XMLTaskDiffOptionsType** type.

```
<xs:simpleType name="XMLTaskDiffOptionsType">
  <xs:restriction base="xs:int">
    <xs:minInclusive value="0"/>
    <xs:maxInclusive value="255"/>
  </xs:restriction>
</xs:simpleType>
```

The bitmask value for the **XMLTaskDiffOptionsType** type is computed according to the following table. The table shows the value for each option that is enabled. The value for the **XMLTaskDiffOptionsType** type is the sum of the values for the options that are enabled. A value of "0" for the **XMLTaskDiffOptionsType** type means that none of the options in the table are selected.

| Value | Option |
|------------|--|
| 1 | Specifies that the order of child nodes is ignored. |
| 2 | Specifies that comment nodes are not compared. |
| 4 | Specifies that processing instructions are not compared. |
| 8 | Specifies that white space is ignored. Significant white spaces are not compared, and all text nodes are normalized by discarding any leading and trailing white space characters (#x9, #x10, #x13, and #x20) and by replacing sequences of white space characters with a single space (#x20) character. |
| 16 | Specifies that namespace names of elements and attributes are ignored. This option also implies that name prefixes are ignored. When this option is selected, two names that have the same local name, but have a different namespace URI and prefix, are treated as the same name. |
| 32 | Specifies that the prefixes of element and attribute names are not compared. When this option is selected, two names that have the same local name and namespace URI, but have a different prefix, are treated as the same name. |
| 64 | Specifies that the XML declaration is ignored. |
| 128 | Specifies that the Document Type Declaration (DTD) is ignored. |

2.7.1.26.3 XMLTaskDiffAlgorithmEnum

The **XMLTaskDiffAlgorithmEnum** type contains the enumeration values for the **DiffAlgorithm** attribute.

The following is the XSD of the **XMLTaskDiffAlgorithmEnum** type.

```
<xs:simpleType name="XMLTaskDiffAlgorithmEnum">
  <xs:restriction base="xs:string">
    <xs:enumeration value="Auto"/>
    <xs:enumeration value="Fast"/>
    <xs:enumeration value="Precise"/>
  </xs:restriction>
</xs:simpleType>
```

The following table specifies the enumeration values for the **XMLTaskDiffAlgorithmEnum** type.

| Enumeration value | Description |
|-------------------|---|
| Auto | Specifies that the XML Task chooses which algorithm to use. |
| Fast | Specifies that a fast, but less precise, algorithm is used. |
| Precise | Specifies that a precise diff algorithm is used. |

2.7.1.26.4 XMLTaskXPathOperationEnum

The **XMLTaskXPathOperationEnum** type contains the enumeration values for the **XPathOperation** attribute.

The following is the XSD of the **XMLTaskXPathOperationEnum** type.

```
<xs:simpleType name="XMLTaskXPathOperationEnum">
  <xs:restriction base="xs:string">
    <xs:enumeration value="Evaluation"/>
    <xs:enumeration value="NodeList"/>
    <xs:enumeration value="Values"/>
  </xs:restriction>
</xs:simpleType>
```

The following table specifies the enumeration values for the **XMLTaskXPathOperationEnum** type.

| Enumeration value | Description |
|-------------------|---|
| Evaluation | Specifies that the results of an XPATH function are returned. |
| NodeList | Specifies that selected nodes of an XPATH operation are returned as an XML fragment. |
| Values | Specifies that the inner text value of all selected nodes are returned, concatenated into a string. |

2.7.1.26.5 XMLTaskValidationTypeEnum

The **XMLTaskValidationTypeEnum** type contains the enumeration values for the **ValidationType** attribute.

The following is the XSD of the **XMLTaskValidationTypeEnum** type.

```
<xs:simpleType name="XMLTaskValidationTypeEnum">
  <xs:restriction base="xs:string">
    <xs:enumeration value="DTD"/>
    <xs:enumeration value="XSD"/>
  </xs:restriction>
</xs:simpleType>
```

The following table specifies the enumeration values for the **XMLTaskValidationTypeEnum** type.

| Enumeration value | Description |
|-------------------|--|
| DTD | Specifies that a DTD is used to validate an XML document. |
| XSD | Specifies that an XSD is used to validate an XML document. |

2.8 Other Types for Package and Non-Package Executables

2.8.1 PropertyElementBaseType

A **Property** element is commonly used throughout the DTSX structure. The **PropertyElementBaseType** complex type provides a base type that many declarations of the **Property** element use for extension.

The following is the XSD of the **PropertyElementBaseType** complex type.

```
<xs:complexType name="PropertyElementBaseType">
  <xs:simpleContent>
    <xs:extension base="xs:anySimpleType">
      <xs:attribute name="DataType" type="DTS:DtsDataTypeEnum"/>
    </xs:extension>
  </xs:simpleContent>
</xs:complexType>
```

Note that the XSD for the **PropertyElementBaseType** complex type allows the type of the value in the element to be **xs:anySimpleType**. However, in individual cases, there are constraints on what the **Property** element value is allowed to be. The additional constraints **MUST** be followed. When such constraints are present, they are specified in the sections where the **Property** element is referenced.

The following table provides additional information about the attributes, types, and constraints for the **PropertyElementBaseType** complex type.

| Attribute | Additional constraints | Description |
|-----------------|---|--|
| DataType | If this optional attribute is specified, the data type of the property element's value MUST be of the specified DataType . Otherwise, the data type of the Property element's value is xs:anySimpleType . | Specifies the data type of the Property element |

2.8.1.1 DtsDataTypeEnum

The **DtsDataTypeEnum** type contains the values that can be specified for the **DTS:DataType** attribute. The value for the element for which a value from the **DtsDataTypeEnum** type is specified as the attribute value **MUST** be of the type that corresponds to the integer value of the enumeration as explained in the following table.

The following is the XSD of the **DtsDataTypeEnum** type.

```
<xs:simpleType name="DtsDataTypeEnum">
  <xs:restriction base="xs:int">
    <xs:enumeration value="1"/>
    <xs:enumeration value="2"/>
    <xs:enumeration value="3"/>
    <xs:enumeration value="4"/>
    <xs:enumeration value="5"/>
    <xs:enumeration value="6"/>
    <xs:enumeration value="7"/>
    <xs:enumeration value="8"/>
    <xs:enumeration value="11"/>
    <xs:enumeration value="13"/>
    <xs:enumeration value="14"/>
    <xs:enumeration value="16"/>
    <xs:enumeration value="17"/>
    <xs:enumeration value="18"/>
    <xs:enumeration value="19"/>
    <xs:enumeration value="20"/>
    <xs:enumeration value="21"/>
    <xs:enumeration value="22"/>
    <xs:enumeration value="23"/>
    <xs:enumeration value="64"/>
    <xs:enumeration value="72"/>
    <xs:enumeration value="129"/>
    <xs:enumeration value="130"/>
    <xs:enumeration value="131"/>
    <xs:enumeration value="133"/>
    <xs:enumeration value="134"/>
    <xs:enumeration value="135"/>
    <xs:enumeration value="139"/>
    <xs:enumeration value="145"/>
    <xs:enumeration value="146"/>
  </xs:restriction>
</xs:simpleType>
```

The following table specifies the enumeration values for the **DtsDataTypeEnum** type.

| Enumeration value | Description |
|-------------------|--------------------|
| 1 | Null value. |
| 2 | Two-byte integer. |
| 3 | Four-byte integer. |
| 4 | Four-byte real. |
| 5 | Eight-byte real. |
| 6 | Currency. |
| 7 | Date. |
| 8 | BSTR. |

| Enumeration value | Description |
|-------------------|---|
| 11 | Boolean. |
| 13 | Object. |
| 14 | Decimal. |
| 16 | One-byte integer. |
| 17 | One-byte unsigned integer. |
| 18 | Two-byte unsigned integer. |
| 19 | Four-byte unsigned integer. |
| 20 | Eight-byte integer. |
| 21 | Eight-byte unsigned integer. |
| 22 | Integer. |
| 23 | Unsigned integer. |
| 64 | An unsigned 64-bit date/time value. Represents the number of 100 nanosecond units since the start of January 1, 1601. |
| 72 | GUID. |
| 129 | A variable-length string with a specified maximum length. |
| 130 | Null-terminated Unicode character string with maximum length of 8000 characters. |
| 131 | Numeric |
| 133 | DbDate, a structure that consists of year, month, day. |
| 134 | DbTime, a structure that consists of hour, minute, second. |
| 135 | DbTimeStamp, a structure that consists of year, month, day, hour, minute, seconds, and fractional parts. |
| 139 | Varnumeric, a structure that can hold very large numeric values. |
| 145 | Same as value 134, but includes fractional seconds. |
| 146 | Same as value 135, but includes a time zone offset. |

2.8.2 PropertyExpressionElementType

The **PropertyExpressionElementType** complex type specifies the type for the **PropertyExpression** element. The **PropertyExpression** element is commonly used throughout the DTSX structure.

The following is the XSD of the **PropertyExpressionElementType** complex type.

```
<xs:complexType name="PropertyExpressionElementType">
  <xs:simpleContent>
    <xs:extension base="xs:anySimpleType">
      <xs:attribute name="Name" type="xs:string" use="required"/>
    </xs:extension>
  </xs:simpleContent>
</xs:complexType>
```



```

    </xs:simpleContent>
  </xs:complexType>

```

The following table provides additional information about the attributes and types for the **PropertyExpressionElementType** complex type.

| Attribute | Constraints | Description |
|-------------|---|---|
| Name | The string given MUST be one of the valid Property element Name attribute values for a Property element attribute on the same object. Or, the string given MUST be a property of a task executable that is defined within the ObjectData element of that task executable. | Specifies the Name attribute of the PropertyExpression element. Each named property has its own use and interpretation. |

2.8.3 LoggingOptionsType

The **LoggingOptionsType** complex type contains information about how logging and filtering of logging information is performed in the containing executable.

The following is the XSD of the **LoggingOptionsType** complex type.

```

<xs:complexType name="LoggingOptionsType">
  <xs:sequence>
    <xs:element name="Property"
      type="DTS:LoggingOptionsPropertyElementType"
      maxOccurs="unbounded"/>
  </xs:sequence>
  <xs:element name="PropertyExpression"
    type="DTS:PropertyExpressionElementType"
    minOccurs="0" maxOccurs="unbounded"/>
  <xs:element name="SelectedLogProvider" minOccurs="0"
    maxOccurs="unbounded" type="DTS:SelectedLogProviderType"/>
</xs:complexType>

```

As the XSD shows, the **Property** element of the **LoggingOptionsType** complex type uses a different base type than the **Property** element does for most other objects in the DTSX structure.

The following table provides additional information about the elements, types, and constraints for the **LoggingOptionsType** complex type.

| Element | Additional constraints | Type definition | Description |
|-----------------|---|------------------------------------|--|
| Property | In some cases, constraints are placed on the Property element's value for specific values of the Name attribute of the Property element. If such constraints exist, they are specified where the meaning of the particular property name is specified. These constraints MUST be followed. If the optional DataType attribute is present, the value of the Property element MUST be of the type indicated by the | Inline in the XSD in this section. | Property elements contain values for many different properties associated with an instance of the containing Executable element, according to the Name attribute of each Property element. |

| Element | Additional constraints | Type definition | Description |
|---------------------------------|--|---|--|
| | Data Type attribute. If the Name attribute of the Property is not equal to "ColumnFilter", the Property element MUST NOT have child elements. If the Name attribute equals "ColumnFilter", the Property element is a complex type. For more information, see Property Name=ColumnFilter . | | |
| PropertyExpression | Additional constraints exist for the PropertyExpression element. These constraints MUST be followed. For a description of the constraints, see PropertyExpressionElementType . | PropertyExpressionElementTy e | The PropertyExpressio n element serves the same purpose as specified for the Property element, except that an expression that is evaluated at run time is contained in the element's value that is stored in the Microsoft SQL Server Integration Services (SSIS) file format. |
| SelectedLogProvide r | None. | SelectedLogProviderType | Contains a reference to the log provider that is to be used. |

2.8.3.1 LoggingOptionsPropertyElementType

The **LoggingOptionsPropertyElementType** complex type is the type of the **Property** element when it appears as a child element to a **LoggingOptions** element. This type differs from the type for the **Property** element in most other places in this document.

The following is the XSD of the **LoggingOptionsPropertyElementType** complex type.

```
<xs:complexType name="LoggingOptionsPropertyElementType" mixed="true">
  <xs:sequence>
    <xs:element name="Property" minOccurs="0" maxOccurs="unbounded">
      <xs:complexType>
        <xs:simpleContent>
          <xs:extension base="xs:anySimpleType">
            <xs:attribute name="Name"
              type="DTS:ColumnEventFilterPropertyNameEnum"
              use="required"/>
            <xs:attribute name="DataType" type="DTS:DtsDataTypeEnum"/>
          </xs:extension>
        </xs:simpleContent>
      </xs:complexType>
    </xs:element>
  </xs:sequence>
  <xs:attribute name="Name"
    type="DTS:LoggingOptionsPropertyNameEnum"
    use="required"/>
  <xs:attribute name="DataType" type="DTS:DtsDataTypeEnum"/>
  <xs:attribute name="EventName" type="xs:string"/>
</xs:complexType>
```

```
</xs:complexType>
```

The following table provides additional information about the attributes and types for the **Property** element and any **Property** element that is a child element to the **Property** element. In the case of **LoggingOptions**, the **Property** element is of type **LoggingOptionsPropertyElementType**, and these attributes are declared in that type definition.

| Attribute | Description |
|------------------|--|
| Name | Specifies the name of the Property element. Each named property has its own use and interpretation. The explanation for the interpretation of each named property is given with the definition of the type for the Name attribute. |
| DataType | The type of the value of the Property element. If present, the Property element value MUST be of this type. |
| EventName | The name of the event to which a column filter applies. |

When the **Property** element has the **Name** attribute value of "ColumnFilter", the **Property** element MUST be a complex type. This complex type contains additional **Property** elements. For more information, see [Property Name=ColumnFilter](#).

2.8.3.1.1 LoggingOptionsPropertyNameEnum

The **LoggingOptionsPropertyNameEnum** type contains the values for the **Name** attribute of the **Property** element that are allowed for the **Property** element of the [LoggingOptionsType](#) complex type.

The following is the XSD of the **LoggingOptionsPropertyNameEnum** type.

```
<xs:simpleType name="LoggingOptionsPropertyNameEnum">
  <xs:restriction base="xs:string">
    <xs:enumeration value="LoggingMode"/>
    <xs:enumeration value="FilterKind"/>
    <xs:enumeration value="EventFilter"/>
    <xs:enumeration value="ColumnFilter"/>
  </xs:restriction>
</xs:simpleType>
```

The following table specifies the enumeration values for the **LoggingOptionsPropertyNameEnum** type.

| Property name | Description |
|---------------------|--|
| LoggingMode | Specifies the logging mode. For additional restrictions, see Property Name=LoggingMode . |
| FilterKind | Specifies whether filtering is done by inclusion or exclusion. For additional restrictions, see Property Name=FilterKind . |
| EventFilter | A string that contains information about the events that are being filtered on. |
| ColumnFilter | Contains the definition of how the columns will be filtered. For additional restrictions, see Property Name=ColumnFilter . |

2.8.3.1.1.1 Property Name=LoggingMode

When the **Property** element's **Name** attribute value is LoggingMode, the values that are allowed for the **Property** element are more restricted than the values that are specified by the XSD definition, which allows the **xs:anySimpleType** type. In this case, the allowed values for the **Property** element value MUST be one of the values in the following table.

| Element value | Type of logging mode specified |
|---------------|--------------------------------|
| 0 | Use Parent Setting |
| 1 | Enabled |
| 2 | Disabled |

2.8.3.1.1.2 Property Name=FilterKind

When the **Property** element's **Name** attribute value is FilterKind, the values that are allowed for the **Property** element are more restricted than the values that are specified by the XSD definition, which allows **xs:anySimpleType**. In this case, the allowed values for the **Property** element value MUST be one of the values in the following table.

| Element value | Type of filtering specified |
|---------------|-----------------------------|
| 0 | Filter by inclusion |
| 1 | Filter by exclusion |

2.8.3.1.1.3 Property Name=ColumnFilter

When the **Property** element's **Name** attribute value is ColumnFilter, the **Property** element is a complex element and MUST contain additional child **Property** elements, as allowed for in the XSD. These child **Property** elements also have a **Name** attribute. The **Name** attribute for the child elements MUST be of type **ColumnEventFilterPropertyNameEnum**.

The following is the XSD of the **ColumnEventFilterPropertyNameEnum** type.

```
<xs:simpleType name="ColumnEventFilterPropertyNameEnum">
  <xs:restriction base="xs:string">
    <xs:enumeration value="Computer"/>
    <xs:enumeration value="Operator"/>
    <xs:enumeration value="SourceName"/>
    <xs:enumeration value="SourceID"/>
    <xs:enumeration value="ExecutionID"/>
    <xs:enumeration value="MessageText"/>
    <xs:enumeration value="DataBytes"/>
  </xs:restriction>
</xs:simpleType>
```

The following table specifies the interpretation of the values in the enumeration. For all of the **Property** names listed in this table, the element value MUST be -1 for TRUE and 0 for FALSE.

| Property name | Description |
|-----------------|---|
| Computer | Specifies whether the local computer name is included in the log entry. |
| Operator | Specifies whether the user account is included in the log entry. |

| Property name | Description |
|--------------------|--|
| SourceName | Specifies whether the name of the task that caused the event is included in the log entry. |
| SourceID | Specifies whether the GUID of the task that caused the event is included in the log entry. |
| ExecutionID | Specifies whether the unique package GUID is included in the log entry. |
| MessageText | Specifies whether message text is included in the log entry. |
| DataBytes | Specifies whether a byte array is included in the log entry. |

2.8.3.2 SelectedLogProviderType

The **SelectedLogProviderType** complex type is a reference to the log provider to be used for the logging that is selected within the **LoggingOptions** element.

The following is the XSD of the **SelectedLogProviderType** complex type.

```
<xs:complexType name="SelectedLogProviderType">
  <xs:sequence/>
  <xs:attribute name="InstanceID" type="DTS:uuid"/>
</xs:complexType>
```

The following table provides additional information about the attributes and types for the **SelectedLogProviderType** complex type.

| Attribute | Description |
|-------------------|---|
| InstanceID | A reference to the DTSID property, as specified in BasePropertyNameEnum for a LogProvider that is contained in the package. |

2.8.4 VariableType

The **VariableType** complex type is used to specify variables that are available to the package. The variables are evaluated at run time.

The following is the XSD of the **VariableType** complex type.

```
<xs:complexType name="VariableType">
  <xs:sequence>
    <xs:element name="Property"
      maxOccurs="unbounded">
      <xs:complexType>
        <xs:complexContent>
          <xs:extension base="DTS:PropertyElementBaseType">
            <xs:attribute name="Name"
              type="DTS:VariablePropertyNameEnum"
              use="required"/>
          </xs:extension>
        </xs:complexContent>
      </xs:complexType>
    </xs:element>
    <xs:element name="PropertyExpression"
      type="DTS:PropertyExpressionElementType"
      minOccurs="0" maxOccurs="unbounded"/>
  </xs:sequence>
</xs:complexType>
```

```

<xs:element name="VariableValue">
  <xs:complexType mixed="true">
    <xs:sequence>
      <xs:any minOccurs="0" maxOccurs="unbounded" processContents="skip"/>
    </xs:sequence>
    <xs:attribute name="DataType" type="DTS:DtsDataTypeEnum"/>
    <xs:attribute name="DataSubType">
      <xs:simpleType>
        <xs:restriction base="xs:string">
          <xs:enumeration value="ManagedSerializable"/>
        </xs:restriction>
      </xs:simpleType>
    </xs:attribute>
  </xs:complexType>
</xs:element>
</xs:sequence>
</xs:complexType>

```

The following table provides additional information about the elements, types, and constraints for the **VariableType** complex type.

| Element | Additional constraints | Type definition | Description |
|---------------------------|--|------------------------------------|---|
| Property | In some cases, constraints are placed on the Property element's value for specific values of the Name attribute of the Property element. If such constraints exist, they are specified where the meaning of the particular property name is specified. These constraints MUST be followed. If the optional DataType attribute is present, the value of the Property element MUST be of the type that is specified by the DataType attribute. | Inline in the XSD in this section. | Property elements contain values for many different properties associated with an instance of the containing Executable element, according to the Name attribute of each Property element. |
| PropertyExpression | Additional constraints exist for the PropertyExpression element. These constraints MUST be followed. For a description of the constraints, see PropertyExpressionElementType . | PropertyExpressionElementType | The PropertyExpression element serves the same purpose as specified for the Property element, except that an expression that is evaluated at run time is contained in the element's value that is stored in the Microsoft SQL Server Integration Services (SSIS) file format. |
| VariableValue | If the optional DataType attribute is included, the value of the element MUST be of the type that is specified by the DataType attribute. If the optional DataSubType attribute is included, the VariableValue element can | | Contains the value that is used literally or is evaluated as an expression. |

| Element | Additional constraints | Type definition | Description |
|---------|--------------------------|-----------------|-------------|
| | contain complex content. | | |

The following table provides additional information about the attributes and types for the **Property** element that is declared inline in the complex type declaration. The **Property** element is an extension of the **PropertyElementBaseType** type with the addition of the **Name** attribute. This attribute is specified in the following table.

| Attribute | Description |
|-------------|--|
| Name | Specifies the name of the Property element. Each named property has its own use and interpretation. The explanation for the interpretation of each named property is given with the definition of the type for the Name attribute. |

The following table specifies the enumeration values for the **VariableType** type.

| Enumeration value | Description |
|----------------------------|--|
| ManagedSerializable | Specifies a managed and serializable object that can be serialized as XML in a DTSX file. This is the only valid value for the DataSubType attribute. |

2.8.4.1 VariablePropertyNameEnum

The **VariablePropertyNameEnum** type contains the values for the **Name** attribute of the property elements that are allowed for the type **VariableType**. The **VariablePropertyNameEnum** type is a union of the enumeration for the [BasePropertyNameEnum](#) type with the additional values that are specified in this section.

The following is the XSD for the **VariablePropertyNameEnum** type.

```
<xs:union memberTypes="DTS:BasePropertyNameEnum">
  <xs:simpleType>
    <xs:restriction base="xs:string">
      <xs:enumeration value="Namespace"/>
      <xs:enumeration value="Expression"/>
      <xs:enumeration value="EvaluateAsExpression"/>
      <xs:enumeration value="ReadOnly"/>
      <xs:enumeration value="RaiseChangedEvent"/>
      <xs:enumeration value="IncludeInDebugDump"/>
    </xs:restriction>
  </xs:simpleType>
</xs:union>
</xs:simpleType>
```

The following table specifies the enumeration values for the **VariablePropertyNameEnum** type.

| Property name | Description |
|-----------------------------|--|
| Namespace | A string value that specifies the namespace that the variable belongs to. |
| Expression | A string value that specifies the expression for the variable. This value is used only if the EvaluateAsExpression property is set to value "-1". |
| EvaluateAsExpression | Specifies whether the variable contains an expression. For additional restrictions, see Property Name=EvaluateAsExpression . |

| Property name | Description |
|---------------------------|--|
| ReadOnly | Specifies whether the variable is read-only. For additional restrictions, see Property Name=ReadOnly . |
| RaiseChangedEvent | Specifies whether the variable is flagged to raise the OnVariableValueChanged event when the variable's value changes. For additional restrictions, see Property Name=RaiseChangedEvent . |
| IncludeInDebugDump | Specifies whether the variable is included in a debug dump. For additional restrictions, see Property Name=IncludeInDebugDump . |

2.8.4.1.1 Property Name=EvaluateAsExpression

When the **Property** element's **Name** attribute value is **EvaluateAsExpression**, the values that are allowed for the **Property** element are more restricted than the values that are specified by the XSD definition, which allows **xs:anySimpleType**. In this case, the allowed values for the **Property** element value MUST be one of the values in the following table.

| Element value | Description |
|---------------|---|
| -1 | Specifies TRUE; the variable contains an expression. |
| 0 | Specifies FALSE; the variable does not contain an expression. |

2.8.4.1.2 Property Name=ReadOnly

When the **Property** element's **Name** attribute value is **ReadOnly**, the values that are allowed for the **Property** element are more restricted than the values that are specified by the XSD definition, which allows **xs:anySimpleType**. In this case, the allowed values for the **Property** element value MUST be one of the values in the following table.

| Element value | Description |
|---------------|---|
| -1 | Specifies TRUE; the variable is read-only. |
| 0 | Specifies FALSE; the variable is not read-only. |

2.8.4.1.3 Property Name=RaiseChangedEvent

When the **Property** element's **Name** attribute value is **RaiseChangedEvent**, the values that are allowed for the **Property** element are more restricted than the values that are specified by the XSD definition, which allows **xs:anySimpleType**. In this case, the allowed values for the **Property** element value MUST be one of the values in the following table.

| Element value | Description |
|---------------|---|
| -1 | Specifies TRUE; the variable is flagged to have the OnVariableChangedEvent event raised when the variable's value changes. |
| 0 | Specifies FALSE; an OnVariableChangedEvent event is not raised when the variable's value changes. |

2.8.4.1.4 Property Name=IncludeInDebugDump

When the **Property** element's **Name** attribute value is **IncludeInDebugDump**, the values that are allowed for the **Property** element are more restricted than the values that are specified by the XSD definition, which allows **xs:anySimpleType**. In this case, the allowed values for the **Property** element value MUST be one of the values in the following table.

| Element value | Description |
|---------------|---|
| 2345 | Specifies TRUE; the variable is included in debug dumps. |
| 6789 | Specifies FALSE; the variable is not included in debug dumps. |

2.8.5 EventHandlerType

The **EventHandlerType** type is used to specify the triggering events and the executables that are executed when a specific event occurs during the execution of a container, task, or package.

The following is the XSD of the **EventHandlerType** complex type.

```
<xs:complexType name="EventHandlerType">
  <xs:sequence>
    <xs:element name="Property"
      maxOccurs="unbounded">
      <xs:complexType>
        <xs:complexContent>
          <xs:extension base="DTS:PropertyElementBaseType">
            <xs:attribute name="Name"
              type="DTS:EventHandlerPropertyNameEnum"
              use="required"/>
          </xs:extension>
        </xs:complexContent>
      </xs:complexType>
    </xs:element>
    <xs:element name="PropertyExpression"
      type="DTS:PropertyExpressionElementType"
      minOccurs="0" maxOccurs="unbounded"/>
    <xs:element name="Variable" type="DTS:VariableType"
      minOccurs="0" maxOccurs="unbounded"/>
    <xs:element name="LoggingOptions" type="DTS:LoggingOptionsType"/>
    <xs:element name="Executable" type="DTS:AnyNonPackageExecutableType"
      minOccurs="0" maxOccurs="unbounded"/>
    <xs:element name="PrecedenceConstraint"
      type="DTS:PrecedenceConstraintType"
      minOccurs="0" maxOccurs="unbounded"/>
  </xs:sequence>
</xs:complexType>
```

The following table provides additional information about the elements, types, and constraints for the **EventHandlerType** complex type.

| Element | Constraints | Type definition | Description |
|-----------------|--|------------------------------------|--|
| Property | In some cases, constraints are placed on the Property element's value for specific values of the Name attribute of | Inline in the XSD in this section. | Specifies values for many different properties |

| Element | Constraints | Type definition | Description |
|-----------------------------|---|---|---|
| | the Property element. If such constraints exist, they are specified where the meaning of the particular property name is specified. These constraints MUST be followed. If the optional DataType attribute is present, the value of the Property element MUST be of the type indicated by the DataType attribute. | | associated with an instance of the containing EventHandler element, according to the Name attribute of each Property element. |
| Variable | None | VariableType | Specifies definitions of variables that can be defined in the context of the event handler. |
| LoggingOptions | None | LoggingOptionsType | Specifies information about what kind of information is logged for this event handler and where that information is recorded. |
| PropertyExpression | Additional constraints exist for the PropertyExpression element. For more information, see PropertyExpressionElementType . | PropertyExpressionElementType | Serves the same purpose as specified for the Property element, except that an expression that is evaluated at run time is contained in the element's value that is stored in the Microsoft SQL Server Integration Services (SSIS) file format. |
| Executable | None | AnyNonPackageExecutableType | Specifies the executables that are executed when the event handler is fired. |
| PrecedenceConstraint | None | PrecedenceConstraintType | Specifies information about precedence |

| Element | Constraints | Type definition | Description |
|---------|-------------|-----------------|--|
| | | | constraints between contained executables in this EventHandler element. |

2.8.5.1 EventHandlerPropertyNameEnum

The **EventHandlerPropertyNameEnum** type contains the values for the **Name** attribute of the property element that are allowed for the **EventHandlerType** type.

The following is the XSD of the **EventHandlerPropertyNameEnum** type.

```
<xs:simpleType name="EventHandlerPropertyNameEnum">
  <xs:union memberTypes="DTS:BaseExecutablePropertyNameEnum">
    <xs:simpleType>
      <xs:restriction base="xs:string">
        <xs:enumeration value="EventID"/>
        <xs:enumeration value="EventName"/>
      </xs:restriction>
    </xs:simpleType>
  </xs:union>
</xs:simpleType>
```

The following table specifies the enumeration values for the **EventHandlerPropertyNameEnum** type. This type is a union of the **BaseExecutablePropertyNameEnum** type with the additional values that are specified in the following table. The values that are specified in this table do not include the values that are already specified for **BaseExecutablePropertyNameEnum**.

| Property name | Description |
|------------------|--|
| EventID | Specifies an integer that identifies this event. <93> |
| EventName | Specifies the name of the event that triggers this event handler. For additional restrictions, see Property Name=EventName . |

2.8.5.1.1 Property Name=EventName

When the **Property** element's **Name** attribute value is **EventName**, the values that are allowed for the **Property** element are more restricted than the values that are specified by the XSD definition, which allows **xs:anySimpleType**. In this case, the allowed values for the **Property** element value MUST be one of the values in the following table.

| Element value | Event description |
|----------------------------|---|
| OnError | Specifies that the event is fired by an error condition. |
| OnExecStatusChanged | Specifies that the event is fired if execution status changes. |
| OnInformation | Specifies that the event is fired by availability of information. |

| Element value | Event description |
|-------------------------------|---|
| OnPostExecute | Specifies that the event is fired after execution is complete. |
| OnPreExecute | Specifies that the event is fired before execution begins. |
| OnPreValidate | Specifies that the event is fired before validation begins. |
| OnProgress | Specifies that the event is fired when progress status update is available. |
| OnQueryCancel | Specifies that the event is fired when a query is canceled. |
| OnTaskFailed | Specifies that the event is fired when a task fails. |
| OnVariableValueChanged | Specifies that the event is fired when a variable value changes. |
| OnWarning | Specifies that the event is fired if a warning condition is encountered. |
| OnCustomEvent | Specifies that the event is fired as defined by a custom event. |

2.8.6 PrecedenceConstraintType

The **PrecedenceConstraintType** complex type is used to specify an object that contains precedence constraints between the executable elements within a package.

The following is the XSD of the **PrecedenceConstraintType** complex type.

```
<xs:complexType name="PrecedenceConstraintType">
  <xs:sequence>
    <xs:element name="Property"
      maxOccurs="unbounded">
      <xs:complexType>
        <xs:complexContent>
          <xs:extension base="DTS:PropertyElementBaseType">
            <xs:attribute name="Name"
              type="DTS:PrecedenceConstraintPropertyNameEnum"
              use="required"/>
          </xs:extension>
        </xs:complexContent>
      </xs:complexType>
    </xs:element>
    <xs:element name="PropertyExpression"
      type="DTS:PropertyExpressionElementType"
      minOccurs="0" maxOccurs="unbounded"/>
    <xs:element name="Executable"
      type="DTS:PrecedenceConstraintExecutableReferenceType"
      minOccurs="1" maxOccurs="unbounded"/>
  </xs:sequence>
</xs:complexType>
```

The following table provides additional information about the elements, types, and constraints for the **PrecedenceConstraintType** complex type.

| Element | Additional constraints | Type definition | Description |
|-----------------|--|------------------------------------|---|
| Property | In some cases, constraints are placed on the Property element's value for specific values of the Name attribute of the | Inline in the XSD in this section. | Property elements contain values for many different properties associated with an |

| Element | Additional constraints | Type definition | Description |
|---------------------------|---|---|--|
| | Property element. If such constraints exist, they are specified where the meaning of the particular property name is specified. These constraints MUST be followed. If the optional DataType attribute is present, the value of the Property element MUST be of the type that is indicated by the DataType attribute. | | instance of the containing Executable element, according to the Name attribute of each Property element. |
| PropertyExpression | Additional constraints exist for the PropertyExpression element. For a description of the constraints, see PropertyExpressionElement Type . | PropertyExpressionElementType | The PropertyExpression element serves the same purpose as specified for the Property element except that an expression that is evaluated at run time is contained in the element's value that is stored in the Microsoft SQL Server Integration Services (SSIS) file format. |
| Executable | None | PrecedenceConstraintExecutableReferenceType | Contains a reference to an Executable upon which this PrecedenceConstraint instance acts. |

The following table provides additional information about the attributes and types for the **Property** element that is declared inline in the complex type declaration. The **Property** element is an extension of the **PropertyElementBaseType** type with the addition of the **Name** attribute. This attribute is specified in the following table.

| Attribute | Description |
|-------------|--|
| Name | Specifies the name of the Property element. Each named property has its own use and interpretation. The explanation for the interpretation of each named property is given with the definition of the type for the Name attribute. |

2.8.6.1 PrecedenceConstraintExecutableReferenceType

The **PrecedenceConstraintExecutableReferenceType** complex type contains information about the **Executable** to which the **PrecedenceConstraint** instance is related.

The following is the XSD of the **PrecedenceConstraintExecutableReferenceType** complex type.

```
<xs:complexType name="PrecedenceConstraintExecutableReferenceType">
```

```

<xs:sequence/>
<xs:attribute name="IDREF" type="DTS:uuid" form="unqualified"/>
<xs:attribute name="IsFrom">
  <xs:simpleType>
    <xs:restriction base="xs:int">
      <xs:minInclusive value="-1"/>
      <xs:maxInclusive value="0"/>
    </xs:restriction>
  </xs:simpleType>
</xs:attribute>
</xs:complexType>

```

The **PrecedenceConstraintExecutableReferenceType** complex type contains no elements or values.

The following table provides additional information about the attributes and types for the **PrecedenceConstraintExecutableReferenceType** complex type.

| Attribute | Constraints | Description |
|---------------|---|---|
| IDREF | The value of this attribute MUST exist as the DTSID property of an Executable element within the package. | Contains the DTSID of the Executable to which this PrecedenceConstraint element is related. |
| IsFrom | None. | Specifies whether this executable is in the "from" direction for the precedence constraint arrow. The interpretation of the values is as follows. -1 = TRUE; this executable is in the "from" direction for the PrecedenceConstraint element. 0 = FALSE; this executable is not in the "from" direction for the PrecedenceConstraint element. |

2.8.6.2 PrecedenceConstraintPropertyNameEnum

The **PrecedenceConstraintPropertyNameEnum** type contains the values for the **Name** attribute of the **Property** elements that are allowed for the [PrecedenceConstraintType](#) complex type.

The following is the XSD of the **PrecedenceConstraintPropertyNameEnum** type.

```

<xs:simpleType name="PrecedenceConstraintPropertyNameEnum">
  <xs:union memberTypes="DTS:BasePropertyNameEnum">
    <xs:simpleType>
      <xs:restriction base="xs:string">
        <xs:enumeration value="Value"/>
        <xs:enumeration value="EvalOp"/>
        <xs:enumeration value="LogicalAnd"/>
        <xs:enumeration value="Expression"/>
      </xs:restriction>
    </xs:simpleType>
  </xs:union>
</xs:simpleType>

```

The following table specifies the enumeration values for the **PrecedenceConstraintPropertyNameEnum** type. The **PrecedenceConstraintPropertyNameEnum** type is a union of the [BasePropertyNameEnum](#) type

with the additional values that are specified in the following table. The values that are specified in this table do not include the values that are already specified for **BasePropertyNameEnum**.

| Property name | Description |
|-------------------|---|
| Value | Specifies that the Property element with Name attribute equal to Value contains the value for this PrecedenceConstraint instance. For additional restrictions, see Property Name=Value . |
| EvalOp | Specifies that the Property element value specifies the type of evaluation operation for this PrecedenceConstraint instance. For additional restrictions, see Property Name=EvalOp . |
| LogicalAnd | Specifies that the Property element value specifies whether to perform a logical AND operation on all the precedence constraints for an executable. For additional restrictions, see Property Name=LogicalAnd . |
| Expression | Specifies that the Property element value contains an expression to be evaluated. |

2.8.6.2.1 Property Name=EvalOp

When the **Property** element's **Name** attribute value is **EvalOp**, the values that are allowed for the **Property** element are more restricted than the values that are specified in the XSD definition, which allows **xs:anySimpleType**. In this case, the allowed values for the **Property** element value MUST be one of the values that are specified in the following table.

| Element value | Type of evaluation operation indicated |
|---------------|--|
| 1 | Expression |
| 2 | Constraint |
| 3 | Expression and constraint |
| 4 | Expression or constraint |

2.8.6.2.2 Property Name=LogicalAnd

When the **Property** element's **Name** attribute value is **LogicalAnd**, the values that are allowed for the **Property** element are more restricted than the values that are specified by the XSD definition, which allows **xs:anySimpleType**. In this case, the allowed values for the **Property** element value MUST be one of the values in the following table.

| Element value | Description |
|---------------|--|
| -1 | Specifies TRUE; the PrecedenceConstraint operation is a logical AND . |
| 0 | Specifies FALSE; the PrecedenceConstraint operation is not a logical AND . |

2.8.6.2.3 Property Name=Value

When the **Property** element's **Name** attribute value is **Value**, the values that are allowed for the **Property** element are more restricted than the values that are specified by the XSD definition, which

allows **xs:anySimpleType**. In this case, the allowed values for the **Property** element value MUST be one of the values in the following table.

| Element value | Description |
|---------------|--|
| 0 | The task completed with a return value of Success. |
| 1 | The task completed with a return value of Failure. |
| 2 | The task ran to completion. |

2.9 Enumeration Types and Supporting Types

2.9.1 BasePropertyNameEnum

The **BasePropertyNameEnum** type contains property names that are common to many other property name enumerations. This type is often extended by other enumeration types.

The following is the XSD of the **BasePropertyNameEnum** type.

```
<xs:simpleType name="BasePropertyNameEnum">
  <xs:restriction base="xs:string">
    <xs:enumeration value="Description"/>
    <xs:enumeration value="DTSID"/>
    <xs:enumeration value="CreationName"/>
    <xs:enumeration value="ObjectName"/>
  </xs:restriction>
</xs:simpleType>
```

The following table specifies the enumeration values for the **BasePropertyNameEnum** type.

| Enumeration value | Description |
|---------------------|--|
| Description | Specifies that the element value contains a human-readable descriptive string. <94> |
| DTSID | Specifies that the element value contains an identifier for this object. Elsewhere within the containing executable or within other executables in the package, the value of DTSID is used to refer to this object. |
| CreationName | Specifies that the element value contains a string that contains the CreationName for this object. |
| ObjectName | Specifies that the element value contains the name given to the object. <95> |

2.9.2 BaseExecutablePropertyNameEnum

The **BaseExecutablePropertyNameEnum** type contains the values for the **Name** attribute of the **Property** element. The **BaseExecutablePropertyNameEnum** type forms the basis for the definition of further types by union or extension.

The following is the XSD of the **BaseExecutablePropertyNameEnum** type.

```
<xs:simpleType name="BaseExecutablePropertyNameEnum">
```



```

<xs:union memberTypes="DTS:BasePropertyNameEnum">
  <xs:simpleType>
    <xs:restriction base="xs:string">
      <xs:enumeration value="ForceExecValue"/>
      <xs:enumeration value="ExecValue"/>
      <xs:enumeration value="ForceExecutionResult"/>
      <xs:enumeration value="Disabled"/>
      <xs:enumeration value="FailPackageOnFailure"/>
      <xs:enumeration value="FailParentOnFailure"/>
      <xs:enumeration value="MaxErrorCount"/>
      <xs:enumeration value="ISOLevel"/>
      <xs:enumeration value="LocaleID"/>
      <xs:enumeration value="TransactionOption"/>
      <xs:enumeration value="DelayValidation"/>
    </xs:restriction>
  </xs:simpleType>
</xs:union>
</xs:simpleType>

```

The following table specifies the enumeration values for the **BaseExecutablePropertyNameEnum** type. This type is a union of the [BasePropertyNameEnum](#) type with the additional values that are discussed in this section. The values that are specified in this table do not include the values that are already specified for **BasePropertyNameEnum**.

| Property name | Description |
|-----------------------------|--|
| ForceExecValue | Specifies that the element value contains a value that determines whether the Executable element is forced to return a value regardless of the exit status of the executable. For additional restrictions, see Property Name=ForceExecValue . |
| ExecValue | Specifies that the element value contains the value that is returned if the value of ForceExecValue is -1 (TRUE). |
| ForceExecutionResult | Specifies that the element value contains the value to return as the result of the execution of the executable instead of the actual result. For additional restrictions, see Property Name=ForceExecutionResult . |
| Disabled | Specifies that the element value contains an indicator for whether the executable is disabled and not available at run time. For additional restrictions, see Property Name=Disabled . |
| FailPackageOnFailure | Specifies that the element value contains an indicator for whether the package will fail because of the failure of this executable. For additional restrictions, see Property Name=FailPackageOnFailure . |
| FailParentOnFailure | Specifies that the element value contains an indicator that specifies whether the parent of the containing Executable element will fail because of the failure of this executable. For additional restrictions, see Property Name=FailParentOnFailure . |
| MaxErrorCount | Specifies that the element value specifies the maximum number of errors before the executable fails. If this count is reached or exceeded, the executable MUST fail. |
| ISOLevel | Specifies that the element value contains the isolation level for the executable. For additional restrictions, see Property Name=ISOLevel . |
| LocaleID | Specifies that the element value contains the language code identifier (LCID) for the language for this executable. |
| TransactionOption | Specifies that the element value specifies the transaction support and the transaction enrollment of the container. For additional restrictions, see Property Name=TransactionOption . |
| DelayValidation | Specifies that the element value specifies whether the validation of the executable is delayed until its container executes. For additional restrictions, see Property |

| Property name | Description |
|-----------------------------|--|
| | Name=DelayValidation . |
| DisableEventHandlers | Specifies that the element value specifies whether event handlers for this executable are disabled. For additional information, see Property Name=DisableEventHandlers . |

2.9.2.1 Property Name=ISOLevel

When the **Property** element's **Name** attribute value is **ISOLevel**, the values that are allowed for the **Property** element are more restricted than the values that are specified by the XSD type definition for either the [PropertyElementBaseType](#) complex type or the **AnyNonPackageExecutablePropertyNameEnum** type.

In this case, the allowed values for the **Property** element value MUST be one of the values that are specified in the following table.

| Element value | Type of isolation level |
|-----------------|-------------------------|
| 1048576 | Serializable |
| 16777216 | Snapshot |
| 65536 | Repeatable Read |
| 1033 | Read Uncommitted |
| 4096 | Read Committed |
| 16 | Chaos |
| -1 | Unspecified |

2.9.2.2 Property Name=TransactionOption

When the **Property** element's **Name** attribute value is **TransactionOption**, the values that are allowed for the **Property** element are more restricted than the values that are specified by the XSD type definition for either the [PropertyElementBaseType](#) complex type or the **AnyNonPackageExecutablePropertyNameEnum** type.

In this case, the allowed values for the **Property** element value MUST be one of the values that are specified in the following table.

| Element value | Support for transactions indicated |
|---------------|------------------------------------|
| 0 | Not supported. |
| 1 | Supported. |
| 2 | Required. |

2.9.2.3 Property Name=ForceExecutionResult

When the **Property** element's **Name** attribute value is **ForceExecutionResult**, the values that are allowed for the **Property** element are more restricted than the values that are specified by the XSD type definition for either the [PropertyElementBaseType](#) complex type or the **AnyNonPackageExecutablePropertyNameEnum** type.

In this case, the allowed values for the **Property** element value MUST be one of the values that are specified in the following table.

| Element value | Execution result that is forced |
|---------------|---------------------------------|
| -1 | None |
| 0 | Success |
| 1 | Failure |
| 2 | Completion |

2.9.2.4 Property Name=ForceExecValue

When the **Property** element's **Name** attribute value is **ForceExecValue**, the values that are allowed for the **Property** element are more restricted than the values that are specified by the XSD type definition for either the [PropertyElementBaseType](#) complex type or the **AnyNonPackageExecutablePropertyNameEnum** type.

In this case, the allowed values for the **Property** element value MUST be one of the values that are specified in the following table.

| Element value | Description |
|---------------|--|
| 0 | False. An execution value is not forced. |
| -1 | True. An execution value is forced. |

2.9.2.5 Property Name=Disabled

When the **Property** element's **Name** attribute value is **Disabled**, the values that are allowed for the **Property** element are more restricted than the values that are specified by the XSD type definition for either the [PropertyElementBaseType](#) complex type or the **AnyNonPackageExecutablePropertyNameEnum** type.

In this case, the allowed values for the **Property** element value MUST be one of the values that are specified in the following table.

| Element value | Description |
|---------------|---|
| 1 | TRUE. The executable is disabled and not available at run time. |
| 0 | FALSE. The executable is enabled. |

2.9.2.6 Property Name=FailPackageOnFailure

When the **Property** element's **Name** attribute value is **FailPackageOnFailure**, the values that are allowed for the **Property** element are more restricted than the values that are specified by the XSD type definition for either the [PropertyElementBaseType](#) complex type or the **AnyNonPackageExecutablePropertyNameEnum** type.

In this case, the allowed values for the **Property** element value MUST be one of the values in the following table.

| Element value | Description |
|---------------|---|
| 1 | TRUE. The package fails if the executable fails. |
| 0 | FALSE. The package does not necessarily fail if the executable fails. |

2.9.2.7 Property Name=FailParentOnFailure

When the **Property** element's **Name** attribute value is **FailParentOnFailure**, the values that are allowed for the **Property** element are more restricted than the values that are specified by the XSD type definition for either the [PropertyElementBaseType](#) complex type or the **AnyNonPackageExecutablePropertyNameEnum** type.

In this case, the allowed values for the **Property** element value MUST be one of the values in the following table.

| Element value | Description |
|---------------|--|
| 1 | TRUE. The parent fails if the executable fails. |
| 0 | FALSE. The parent does not necessarily fail if the executable fails. |

2.9.2.8 Property Name=DelayValidation

When the **Property** element's **Name** attribute value is **DelayValidation**, the values that are allowed for the **Property** element are more restricted than the values that are specified by the XSD type definition for either the [PropertyElementBaseType](#) complex type or the **AnyNonPackageExecutablePropertyNameEnum** type.

In this case, the allowed values for the **Property** element value MUST be one of the values in the following table.

| Element value | Description |
|---------------|--|
| 1 | TRUE. The validation of the executable is delayed until run time. |
| 0 | FALSE. The validation of the executable is not delayed until run time. |

2.9.3 AllExecutablePropertyNameEnum

The **AllExecutablePropertyNameEnum** type contains the values for the **Name** attribute of the **Property** element that are allowed on all executable types.

The following is the XSD of the **AllExecutablePropertyNameEnum** type.

```
<xs:simpleType name="AllExecutablePropertyNameEnum">
  <xs:union memberTypes="DTS:BaseExecutablePropertyNameEnum">
    <xs:simpleType>
      <xs:restriction base="xs:string">
        <xs:enumeration value="DisableEventHandlers"/>
      </xs:restriction>
    </xs:simpleType>
  </xs:union>
</xs:simpleType>
```

The following table specifies the enumeration values for the **AllExecutablePropertyNameEnum** type. This type is a union of the [BaseExecutablePropertyNameEnum](#) type with the additional values that are specified in this section. The values that are specified in this table do not include the values that are already specified for **BaseExecutablePropertyNameEnum**.

| Property name | Description |
|-----------------------------|--|
| DisableEventHandlers | Specifies that the element value specifies whether event handlers for this executable are disabled. For additional information, see Property Name=DisableEventHandlers . |

2.9.3.1 Property Name=DisableEventHandlers

When the **Property** element's **Name** attribute value is **DisableEventHandlers**, the values that are allowed for the **Property** element are more restricted than the values that are specified by the XSD type definition for either the [PropertyElementBaseType](#) complex type or the **AnyNonPackageExecutablePropertyNameEnum** type. In this case, the allowed values for the **Property** element value MUST be one of the values in the following table.

| Element value | Description |
|---------------|---|
| -1 | TRUE. Any event handler that is applied to this executable is disabled. |
| 0 | FALSE. Event handlers that are applied to this executable are not disabled. |

2.9.4 UUID

The **UUID** type is used to specify the text pattern for references to DTSID values.

The following is the XSD of the **UUID** type.

```
<xs:simpleType name="uuid">
  <xs:restriction base="xs:string">
    <xs:pattern value="\{[0-9a-zA-Z]{8}-[0-9a-zA-Z]{4}-[0-9a-zA-Z]{4}-[0-9a-zA-Z]{4}-[0-9a-zA-Z]{12}\}" />
  </xs:restriction>
</xs:simpleType>
```

2.9.5 PasswordElementType

The **PasswordElementType** complex type specifies the type of the **Password** element that is a child element of other elements within the Microsoft SQL Server Integration Services (SSIS) package file format. The **PasswordElementType** complex type is used to store the password information for connecting to a data source.

The following is the XSD of the **PasswordElementType** complex type.

```
<xs:complexType name="PasswordElementType">
  <xs:simpleContent>
    <xs:extension base="xs:string">
      <xs:attribute name="Sensitive" form="unqualified">
        <xs:simpleType>
          <xs:restriction base="xs:int">
            <xs:minInclusive value="0"/>
            <xs:maxInclusive value="1"/>
          </xs:restriction>
        </xs:simpleType>
      </xs:attribute>
      <xs:attribute name="Encrypted" form="unqualified">
        <xs:simpleType>
          <xs:restriction base="xs:int">
            <xs:minInclusive value="0"/>
            <xs:maxInclusive value="1"/>
          </xs:restriction>
        </xs:simpleType>
      </xs:attribute>
    </xs:extension>
  </xs:simpleContent>
</xs:complexType>
```

The **PasswordElementType** complex type MUST NOT contain any elements.

The following table specifies the attributes for the **PasswordElementType** complex type.

| Attribute | Description |
|------------------|--|
| Sensitive | Specifies that the element value contains an indicator for whether the password information is treated as sensitive. The integer value has the following interpretations: 0 = FALSE; the password is not considered to be sensitive. 1 = TRUE; the password is considered to be sensitive. |
| Encrypted | Specifies that the element value contains an indicator for whether the element value is encrypted. The integer value has the following interpretations: 0 = FALSE; the element value is not encrypted. 1 = TRUE; the element value is encrypted. |

2.9.6 SourceTypeEnum

The **SourceTypeEnum** type contains enumeration values that are used to specify the type of an input source. The **SourceTypeEnum** type is referenced by other types in the Microsoft SQL Server Integration Services (SSIS) package file format.

The following is the XSD for the **SourceTypeEnum** type.

```
<xs:simpleType name="SqlStmtSourceTypeEnum">
  <xs:restriction base="xs:string">
```

```

    <xs:enumeration value="DirectInput"/>
    <xs:enumeration value="FileConnection"/>
    <xs:enumeration value="Variable"/>
  </xs:restriction>
</xs:simpleType>

```

The following table specifies the enumeration values for the **SourceTypeEnum** type.

| Enumeration value | Description |
|-----------------------|---|
| DirectInput | Specifies that the source text is contained inline in a package file as the value of another element. |
| FileConnection | Specifies that the source text is contained in a file connection. |
| Variable | Specifies that the source text is contained in a variable. |

2.9.7 IfObjectExistsEnum

The **IfObjectExistsEnum** type contains the enumeration values for the **IfObjectExists** attribute.

The following is the XSD of the **IfObjectExistsEnum** type.

```

<xs:simpleType name="IfObjectExistsEnum">
  <xs:restriction base="xs:string">
    <xs:enumeration value="FailTask"/>
    <xs:enumeration value="Overwrite"/>
    <xs:enumeration value="Skip"/>
  </xs:restriction>
</xs:simpleType>

```

The following table specifies the enumeration values for the **IfObjectExistsEnum** type.

| Enumeration value | Description |
|-------------------|---|
| FailTask | Specifies that the task MUST fail if the object exists at the destination for the transfer. |
| Overwrite | Specifies that the task MUST overwrite the previously existing object if the object exists at the destination for the transfer. |
| Skip | Specifies that the task MUST skip the transfer of such objects if the object exists at the destination for the transfer. |

2.9.8 DestinationTypeEnum

The **DestinationTypeEnum** type contains enumeration values that are used to specify the type of a destination source. The **DestinationTypeEnum** type is referenced by other types in the Microsoft SQL Server Integration Services (SSIS) package file format.

The following is the XSD of the **DestinationTypeEnum** type.

```

<xs:simpleType name="DestinationTypeEnum">

```

```

<xs:restriction base="xs:string">
  <xs:enumeration value="FileConnection"/>
  <xs:enumeration value="Variable"/>
</xs:restriction>
</xs:simpleType>

```

The following table specifies the enumeration values for the **DestinationTypeEnum** type.

| Enumeration value | Description |
|-----------------------|--|
| FileConnection | Specifies that the source is contained in a file connection. |
| Variable | Specifies that the source is contained in a variable. |

2.9.9 InnerObjectObjectType

The **InnerObjectObjectType** complex type specifies a type that can contain any element. It is used for extending and customizing Executable elements and **LogProvider** elements.

The following is the XSD of the **InnerObjectObjectType** complex type.

```

<xs:complexType name="InnerObjectObjectType">
  <xs:sequence>
    <xs:any minOccurs="0" maxOccurs="unbounded"
      namespace="##any" processContents="skip"/>
  </xs:sequence>
</xs:complexType>

```

The **InnerObjectObjectType** type MAY contain any element in any namespace. [<96>](#)

2.10 Custom Packages

Microsoft SQL Server Integration Services (SSIS) allows users to create custom packages that execute new objects beyond the objects that ship with the standard Integration Services system. These packages are described by the XSD in section [2](#) of this document. Users can create the following custom objects:

- [Executable](#)
- [ConnectionManager](#)
- [Log Provider](#)
- [ForEachEnumerator](#)
- [Component](#)

The following sections describe these custom objects and their impact on the XSD of the DTSX structure format.

Note For more information about the environment for the development of custom package objects, see [\[MSDN-EPCO\]](#).

2.10.1 Custom Executable

Software developers can author a custom executable using a software development environment and a programming language. These custom executables can then be executed as part of a Microsoft SQL Server Integration Services (SSIS) package. When a custom executable is authored, the XSD for the Integration Services format structure can change in the following way:

- The **ObjectData** element of the executable can contain any XML that the executable author defines to support the authored executable.

The following section explains the impact on the XSD for custom executables.

2.10.1.1 ExecutableObjectType Type Replacement

In the case of custom packages, the definition of the [ExecutableObjectType](#) type is replaced with the following XSD definition for the **ExecutableObjectTypeCustom** type. All references to the **ExecutableObjectType** type would be replaced with a reference to the **ExecutableObjectTypeCustom** type. The original **ExecutableObjectType** type has an XSD **choice** element, which allows the choice among elements that are specific to the variety of executable types that ship with the Microsoft SQL Server Integration Services (SSIS) system. In **ExecutableObjectTypeCustom**, the choice is constrained to one specific element from within the original choice: the **InnerObject** element. The Integration Services system will not interpret the contents of the **InnerObject** element, and it will simply pass it to the custom executable when asked to do so.

The following is the XSD for the **ExecutableObjectTypeCustom** type.

```
<xs:complexType name="ExecutableObjectTypeCustom">
  <xs:choice>
    <xs:element name="InnerObject" type="DTS:InnerObjectObjectType"
      form="unqualified"/>
  </xs:choice>
</xs:complexType>
```

2.10.2 Custom ConnectionManager

Software developers can author a custom connection manager using a software development environment and a programming language to connect to a data source that is not supported by the Integration Services product. The custom connection manager is referenced from within the Integration Services package file like any other connection manager. When it is necessary to connect to the external data source, Integration Services executes the custom-authored code to do so.

To execute the custom connection manager code, the **DTSID** attribute of the connection manager **MUST** be set to the GUID that references the registered COM component that implements the required interfaces or **MUST** be set to the full path of the .NET Framework assembly.

The following sections explain the impact on the XSD for custom executables.

2.10.2.1 ConnectionManagerObjectType Type Replacement

In the case of a custom connection manager, the definition of the [ConnectionManagerObjectType](#) type is replaced with the following XSD definition for the **ConnectionManagerObjectTypeCustom** type. All references to the **ConnectionManagerObjectType** type would be replaced with a reference to the **ConnectionManagerObjectTypeCustom** type. The Microsoft SQL Server Integration Services (SSIS) system will not interpret the contents of the **ObjectData** element, and it will simply pass it to the custom connection manager when asked to do so.

The following is the XSD for the **ConnectionManagerObjectDataTypeCustom** type.

```
<xs:complexType name="ConnectionManagerObjectDataTypeCustom">
  <xs:sequence>
    <xs:any minOccurs="0" maxOccurs="unbounded"
      namespace="##any" processContents="skip"/>
  </xs:sequence>
</xs:complexType>
```

2.10.3 Custom Log Provider

Software developers can author a custom log provider using a software development environment and a programming language to connect to and use a logging service that is not supported by the Integration Services product. The custom log provider is referenced from within the Integration Services package file like any other log provider. When it is necessary to access the log provider, Integration Services executes the custom-authored code to do so.

To execute the custom log provider code, the **DTSID** attribute of the LogProvider element **MUST** be set to the GUID that references the registered COM component that implements the required interfaces or **MUST** be set to the full path of the .NET Framework assembly.

Custom log providers impose no changes on the XSD in this document, because the [LogProviderObjectDataType](#) type already accommodates the presence of a custom log provider.

2.10.4 Custom ForEachEnumerator

Software developers can author a custom ForEachEnumerator to enumerate over objects for which a standard enumerator is not provided by the Integration Services product, using a software development environment and a programming language.

To execute the custom ForEachEnumerator code, the **DTSID** attribute of the ForEachEnumerator **MUST** be set to the GUID that references the registered COM component that implements the required interfaces or **MUST** be set to the full path of the .NET Framework assembly.

The following section explains the impact on the XSD for the custom ForEachEnumerator.

2.10.4.1 ForEachEnumeratorObjectDataType Type Replacement

In the case of a custom ForEachEnumerator, the definition of the [ForEachEnumeratorObjectDataType](#) type is replaced with the following XSD definition for the **ForEachEnumeratorObjectDataTypeCustom** type. All references to the **ForEachEnumeratorObjectDataType** type would be replaced with a reference to the **ForEachEnumeratorObjectDataTypeCustom** type. The Integration Services system will not interpret the contents of the **ObjectData** element, and it will simply pass it to the custom connection manager when asked to do so.

The following is the XSD for the **ForEachEnumeratorObjectDataTypeCustom** type.

```
<xs:complexType name="ForEachEnumeratorObjectDataTypeCustom">
  <xs:sequence>
    <xs:any minOccurs="0" maxOccurs="unbounded"
      namespace="##any" processContents="skip"/>
  </xs:sequence>
</xs:complexType>
```

2.10.5 Custom Component

Software developers can author a custom component that will run within a Pipeline Task executable by using a software development environment and a programming language. When a custom component is authored, the author can define additional properties that are persisted in the XML beyond the properties that ship with Integration Services. The following sections define the impact on the XSD to accommodate development of custom components.

2.10.5.1 PipelineComponentComponentClassIDEnum Type Replacement

To execute the custom component, the value of the **ComponentClassID** attribute of the component element MUST point to the custom code executable. The type of the **ComponentClassID** attribute MUST be changed to be the type that is defined in this section, the **PipelineComponentComponentClassIDEnumCustom** type. All references within the XSD to the [PipelineComponentComponentClassIDEnum](#) type MUST be changed to reference the **PipelineComponentComponentClassIDEnumCustom** type.

The following is the XSD for the **PipelineComponentComponentClassIDEnumCustom** type.

```
<xs:simpleType name="PipelineComponentComponentClassIDEnumCustom">
  <xs:union memberTypes="DTS:PipelineComponentComponentClassIDEnum">
    <xs:simpleType>
      <xs:restriction base="xs:string"/>
    </xs:simpleType>
  </xs:union>
</xs:simpleType>
```

2.10.5.2 PipelineComponentPropertyNameEnum Type Replacement

In a custom component, the developer can add additional properties that appear in the properties collection that is a child collection of the **component** element. To accommodate the presence of these additional properties, the [PipelineComponentPropertyNameEnum](#) type is replaced by the following definition of the **PipelineComponentPropertyNameEnumCustom** type. All references within the XSD to the **PipelineComponentPropertyNameEnum** type MUST be changed to reference the **PipelineComponentPropertyNameEnumCustom** type to accommodate the presence of custom components in the package file.

The following is the XSD for the **PipelineComponentPropertyNameEnumCustom** type.

```
<xs:simpleType name="PipelineComponentPropertyNameEnumCustom">
  <xs:union memberTypes="DTS:PipelineComponentPropertyNameEnum">
    <xs:simpleType>
      <xs:restriction base="xs:string"/>
    </xs:simpleType>
  </xs:union>
</xs:simpleType>
```

2.10.5.3 PipelineComponentInputPropertyNameEnum Type Replacement

In a custom component, the developer can add additional properties that appear in the properties collection that is a child collection of the **input** element. To accommodate the presence of these additional properties, the [PipelineComponentInputPropertyNameEnum](#) type is replaced by the following definition of the **PipelineComponentInputPropertyNameEnumCustom** type. All references within the XSD to the **PipelineComponentInputPropertyNameEnum** type MUST be changed to reference the **PipelineComponentInputPropertyNameEnumCustom** type to accommodate the presence of custom components in the package file.

The following is the XSD for the **PipelineComponentInputPropertyNameEnumCustom** type.

```
<xs:simpleType name="PipelineComponentInputPropertyNameEnumCustom">
  <xs:union memberTypes="DTS:PipelineComponentInputPropertyNameEnum">
    <xs:simpleType>
      <xs:restriction base="xs:string"/>
    </xs:simpleType>
  </xs:union>
</xs:simpleType>
```

2.10.5.4 PipelineComponentOutputPropertyNameEnum Type Replacement

In a custom component, the developer can add additional properties that appear in the properties collection that is a child collection of the **output** element. To accommodate the presence of these additional properties, the **PipelineComponentOutputPropertyNameEnum** type is replaced by the following definition of the **PipelineComponentOutputPropertyNameEnumCustom** type. All references within the XSD to the **PipelineComponentOutputPropertyNameEnum** type MUST be changed to reference the **PipelineComponentOutputPropertyNameEnumCustom** type to accommodate the presence of custom components in the package file.

The following is the XSD for the **PipelineComponentOutputPropertyNameEnumCustom** type.

```
<xs:simpleType name="PipelineComponentOutputPropertyNameEnumCustom">
  <xs:union memberTypes="DTS:PipelineComponentOutputPropertyNameEnum">
    <xs:simpleType>
      <xs:restriction base="xs:string"/>
    </xs:simpleType>
  </xs:union>
</xs:simpleType>
```

2.10.5.5 PipelineComponentInputColumnPropertyNameEnum Type Replacement

In a custom component, the developer can add additional properties that appear in the properties collection that is a child collection of the **inputColumn** element. To accommodate the presence of these additional properties, the **PipelineComponentInputColumnPropertyNameEnum** type is replaced by the following definition of the **PipelineComponentInputColumnPropertyNameEnumCustom** type. All references within the XSD to the **PipelineComponentInputColumnPropertyNameEnum** type MUST be changed to reference the **PipelineComponentInputColumnPropertyNameEnumCustom** type to accommodate the presence of custom components in the package file.

The following is the XSD for the **PipelineComponentInputColumnPropertyNameEnumCustom** type.

```
<xs:simpleType
  name="PipelineComponentInputColumnPropertyNameEnumCustom">
  <xs:union
    memberTypes="DTS:PipelineComponentInputColumnPropertyNameEnum">
    <xs:simpleType>
      <xs:restriction base="xs:string"/>
    </xs:simpleType>
  </xs:union>
</xs:simpleType>
```

2.10.5.6 PipelineComponentOutputColumnNameEnum Type Replacement

In a custom component, the developer can add additional properties that appear in the properties collection that is a child collection of the **outputColumn** element. To accommodate the presence of these additional properties, the PipelineComponentOutputColumnNameEnum type is replaced by the following definition of the **PipelineComponentOutputColumnNameEnumCustom** type. All references within the XSD to the **PipelineComponentOutputColumnNameEnum** type MUST be changed to reference the **PipelineComponentOutputColumnNameEnumCustom** type to accommodate the presence of custom components in the package file.

The following is the XSD for the **PipelineComponentOutputColumnNameEnumCustom** type.

```
<xs:simpleType
  name="PipelineComponentOutputColumnNameEnumCustom">
  <xs:union
    memberTypes="DTS:PipelineComponentOutputColumnNameEnum">
    <xs:simpleType>
      <xs:restriction base="xs:string"/>
    </xs:simpleType>
  </xs:union>
</xs:simpleType>
```

3 Structure Examples

3.1 Lookup and Fuzzy Lookup Components with Error Output

The following example is taken from [Haselden], with modifications.

The following **package file** illustrates a Pipeline Task that contains several components within the pipeline. The Microsoft SQL Server Integration Services (SSIS) user interface in the designer that represents this package example is shown in the following diagram.

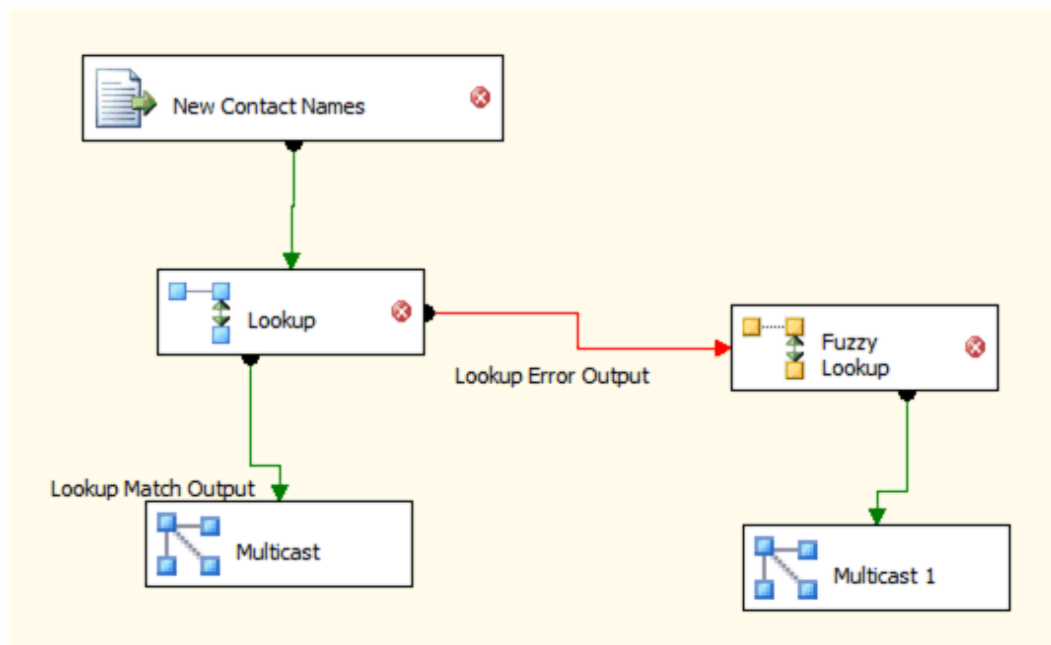

Figure 3: Pipeline Task in Integration Services user interface

The Lookup Component has both a standard output and an error output. In the case of error output from the Lookup Component, the data flow path is different from the case in which the lookup operation succeeds. In the following structure example, the **inputs** element and the **outputs** element of the Lookup Component illustrate its two different output paths.

```
<?xml version="1.0"?>
<DTS:Executable xmlns:DTS="www.microsoft.com/SqlServer/Dts"
  DTS:ExecutableType="SSIS.Package.2">
  <DTS:Property DTS:Name="PackageFormatVersion">3</DTS:Property>
  <DTS:Property DTS:Name="VersionComments"></DTS:Property>
  <DTS:Property DTS:Name="CreatorName">Kirk Haselden</DTS:Property>
  <DTS:Property DTS:Name="CreatorComputerName">ROME0</DTS:Property>
  <DTS:Property DTS:Name="CreationDate" DTS:DataType="7">
    7/16/2005 3:59:24 PM</DTS:Property>
  <DTS:Property DTS:Name="PackageType">5</DTS:Property>
  <DTS:Property DTS:Name="ProtectionLevel">0</DTS:Property>
  <DTS:Property DTS:Name="MaxConcurrentExecutables">-1</DTS:Property>
  <DTS:Property DTS:Name="PackagePriorityClass">0</DTS:Property>
  <DTS:Property DTS:Name="VersionMajor">1</DTS:Property>
  <DTS:Property DTS:Name="VersionMinor">0</DTS:Property>
  <DTS:Property DTS:Name="VersionBuild">51</DTS:Property>
  <DTS:Property DTS:Name="VersionGUID">
    {87D0FDC5-59D6-45C3-93DF-442F40DE90CC}</DTS:Property>
  <DTS:Property DTS:Name="EnableConfig">-1</DTS:Property>
  <DTS:Property DTS:Name="CheckpointFileName"></DTS:Property>
</DTS:Executable>
```

```

<DTS:Property DTS:Name="SaveCheckpoints">0</DTS:Property>
<DTS:Property DTS:Name="CheckpointUsage">0</DTS:Property>
<DTS:Property DTS:Name="SuppressConfigurationWarnings">0</DTS:Property>
<DTS:Property DTS:Name="LastModifiedProductVersion">10.0.1600.22
</DTS:Property>
<DTS:Property DTS:Name="ForceExecValue">0</DTS:Property>
<DTS:Property DTS:Name="ExecValue" DTS:DataType="3">0</DTS:Property>
<DTS:Property DTS:Name="ForceExecutionResult">-1</DTS:Property>
<DTS:Property DTS:Name="Disabled">0</DTS:Property>
<DTS:Property DTS:Name="FailPackageOnFailure">0</DTS:Property>
<DTS:Property DTS:Name="FailParentOnFailure">0</DTS:Property>
<DTS:Property DTS:Name="MaxErrorCount">1</DTS:Property>
<DTS:Property DTS:Name="ISOLevel">1048576</DTS:Property>
<DTS:Property DTS:Name="LocaleID">1033</DTS:Property>
<DTS:Property DTS:Name="TransactionOption">1</DTS:Property>
<DTS:Property DTS:Name="DelayValidation">0</DTS:Property>
<DTS:Property DTS:Name="ObjectName">FuzzyLookup</DTS:Property>
<DTS:Property DTS:Name="DTSID">{ECF155AC-F433-4930-A0A1-BE9B065E004D}
</DTS:Property>
<DTS:Property DTS:Name="Description"></DTS:Property>
<DTS:Property DTS:Name="CreationName">SSIS.Package.2</DTS:Property>
<DTS:Property DTS:Name="DisableEventHandlers">0</DTS:Property>
<DTS:ConnectionManager>
  <DTS:Property DTS:Name="DelayValidation">0</DTS:Property>
  <DTS:Property DTS:Name="ObjectName">.\SQL2K5.AdventureWorks
  </DTS:Property>
  <DTS:Property DTS:Name="DTSID">
    {FAFAC1E8-81D4-4E0D-A5A9-ABAD9BF38826}</DTS:Property>
  <DTS:Property DTS:Name="Description"></DTS:Property>
  <DTS:Property DTS:Name="CreationName">OLEDB</DTS:Property>
  <DTS:PropertyExpression DTS:Name="ServerName">@[SAMPLES::SERVERNAME]
  </DTS:PropertyExpression>
  <DTS:ObjectData>
    <DTS:ConnectionManager>
      <DTS:Property DTS:Name="Retain">0</DTS:Property>
      <DTS:Property DTS:Name="ConnectionString">
Data Source=.;Initial Catalog=AdventureWorks;Provider=SQLNCLI10;Integrated Security=SSPI;Auto
Translate=False;
</DTS:Property>
    </DTS:ConnectionManager>
  </DTS:ObjectData>
</DTS:ConnectionManager>
<DTS:ConnectionManager>
  <DTS:Property DTS:Name="DelayValidation">0</DTS:Property>
  <DTS:Property DTS:Name="ObjectName">New Contacts</DTS:Property>
  <DTS:Property DTS:Name="DTSID">{E97F2191-17D8-400B-9EE6-7823482A958C}
  </DTS:Property>
  <DTS:Property DTS:Name="Description"></DTS:Property>
  <DTS:Property DTS:Name="CreationName">FLATFILE</DTS:Property>
  <DTS:PropertyExpression DTS:Name="ConnectionString">
@[SAMPLES::ROOTWD] + "\\SAMPLEDATA\\NewContacts.txt"</DTS:PropertyExpression>
  <DTS:ObjectData>
    <DTS:ConnectionManager>
      <DTS:Property DTS:Name="FileUsageType">0</DTS:Property>
      <DTS:Property DTS:Name="Format">Delimited</DTS:Property>
      <DTS:Property DTS:Name="LocaleID">1033</DTS:Property>
      <DTS:Property DTS:Name="Unicode">0</DTS:Property>
      <DTS:Property DTS:Name="HeaderRowsToSkip">0</DTS:Property>
      <DTS:Property DTS:Name="HeaderRowDelimiter"
        xml:space="preserve">_x000D_x000A_</DTS:Property>
      <DTS:Property DTS:Name="ColumnNamesInFirstDataRow">-1</DTS:Property>
      <DTS:Property DTS:Name="RowDelimiter"
        xml:space="preserve"></DTS:Property>
      <DTS:Property DTS:Name="DataRowsToSkip">0</DTS:Property>
      <DTS:Property DTS:Name="TextQualifier">&lt;none&gt;</DTS:Property>
      <DTS:Property DTS:Name="CodePage">1252</DTS:Property>
      <DTS:Property DTS:Name="ConnectionString">
E:\BOOKSHARE\BOOKS\SSIS\SSIS_R2\SAMPLES\SAMPLEDATA\NewContacts.txt
</DTS:Property>
    </DTS:ConnectionManager>
  </DTS:ObjectData>
</DTS:ConnectionManager>

```

```

<DTS:FlatFileColumn>
  <DTS:Property DTS:Name="ColumnType">Delimited</DTS:Property>
  <DTS:Property DTS:Name="ColumnDelimiter"
    xml:space="preserve">_x0009_</DTS:Property>
  <DTS:Property DTS:Name="ColumnWidth">0</DTS:Property>
  <DTS:Property DTS:Name="MaximumWidth">50</DTS:Property>
  <DTS:Property DTS:Name="DataType">129</DTS:Property>
  <DTS:Property DTS:Name="DataPrecision">0</DTS:Property>
  <DTS:Property DTS:Name="DataScale">0</DTS:Property>
  <DTS:Property DTS:Name="TextQualified">-1</DTS:Property>
  <DTS:Property DTS:Name="ObjectName">FirstName</DTS:Property>
  <DTS:Property DTS:Name="DTSID">
    {64661EFB-1C85-47C6-974D-BDFC7441D404}</DTS:Property>
  <DTS:Property DTS:Name="Description"></DTS:Property>
  <DTS:Property DTS:Name="CreationName"></DTS:Property>
</DTS:FlatFileColumn>
<DTS:FlatFileColumn>
  <DTS:Property DTS:Name="ColumnType">Delimited</DTS:Property>
  <DTS:Property DTS:Name="ColumnDelimiter"
    xml:space="preserve">_x000D_x000A_</DTS:Property>
  <DTS:Property DTS:Name="ColumnWidth">0</DTS:Property>
  <DTS:Property DTS:Name="MaximumWidth">50</DTS:Property>
  <DTS:Property DTS:Name="DataType">129</DTS:Property>
  <DTS:Property DTS:Name="DataPrecision">0</DTS:Property>
  <DTS:Property DTS:Name="DataScale">0</DTS:Property>
  <DTS:Property DTS:Name="TextQualified">-1</DTS:Property>
  <DTS:Property DTS:Name="ObjectName">LastName</DTS:Property>
  <DTS:Property DTS:Name="DTSID">
    {2DEA7754-8936-4BFB-822E-F0014DE3C9C0}</DTS:Property>
  <DTS:Property DTS:Name="Description"></DTS:Property>
  <DTS:Property DTS:Name="CreationName"></DTS:Property>
</DTS:FlatFileColumn>
</DTS:ConnectionManager>
</DTS:ObjectData>
</DTS:ConnectionManager>
<DTS:Configuration>
  <DTS:Property DTS:Name="ConfigurationType">2</DTS:Property>
  <DTS:Property DTS:Name="ConfigurationString">SSISSAMPLESROOT
</DTS:Property>
  <DTS:Property DTS:Name="ConfigurationVariable">
\Package.Variables[SAMPLES::ROOTWD].Properties[Value]</DTS:Property>
  <DTS:Property DTS:Name="ObjectName">Configure The Root Folder
</DTS:Property>
  <DTS:Property DTS:Name="DTSID">{90405045-3A91-43C2-B759-6C183C0E81A6}
</DTS:Property>
  <DTS:Property DTS:Name="Description"></DTS:Property>
  <DTS:Property DTS:Name="CreationName"></DTS:Property>
</DTS:Configuration>
<DTS:Configuration>
  <DTS:Property DTS:Name="ConfigurationType">2</DTS:Property>
  <DTS:Property DTS:Name="ConfigurationString">
  SSISSAMPLESERVER</DTS:Property>
  <DTS:Property DTS:Name="ConfigurationVariable">
\Package.Variables[SAMPLES::SERVERNAME].Properties[Value]</DTS:Property>
  <DTS:Property DTS:Name="ObjectName">Configure The Sample Server Name
</DTS:Property>
  <DTS:Property DTS:Name="DTSID">{A9F64F24-15C2-4198-A308-F9124C48468D}
</DTS:Property>
  <DTS:Property DTS:Name="Description"></DTS:Property>
  <DTS:Property DTS:Name="CreationName"></DTS:Property>
</DTS:Configuration>
<DTS:Configuration>
  <DTS:Property DTS:Name="ConfigurationType">2</DTS:Property>
  <DTS:Property DTS:Name="ConfigurationString">SSISSAMPLESWORKINGFOLDER
</DTS:Property>
  <DTS:Property DTS:Name="ConfigurationVariable">
\Package.Variables[SAMPLES::WORKINGFOLDER].Properties[Value]</DTS:Property>
  <DTS:Property DTS:Name="ObjectName">
  Configure the Working Folder variable</DTS:Property>

```



```

    <DTS:Property DTS:Name="DTSID">{1BAB0708-C962-4F9B-BFD6-EC434567ACAF}
  </DTS:Property>
  <DTS:Property DTS:Name="Description"></DTS:Property>
  <DTS:Property DTS:Name="CreationName"></DTS:Property>
</DTS:Configuration>
<DTS:Variable>
  <DTS:Property DTS:Name="Expression">@ROOTWD + "\\\" + @SAMPLESUBFOLDER
  </DTS:Property>
  <DTS:Property DTS:Name="EvaluateAsExpression">-1</DTS:Property>
  <DTS:Property DTS:Name="Namespace">SAMPLES</DTS:Property>
  <DTS:Property DTS:Name="ReadOnly">0</DTS:Property>
  <DTS:Property DTS:Name="RaiseChangedEvent">0</DTS:Property>
  <DTS:Property DTS:Name="IncludeInDebugDump">2345</DTS:Property>
  <DTS:Property DTS:Name="ObjectName">CURRENTWD</DTS:Property>
  <DTS:Property DTS:Name="DTSID">{E05C4384-FA46-4EDB-9E41-E0CDD6DD4DC6}
  </DTS:Property>
  <DTS:Property DTS:Name="Description"></DTS:Property>
  <DTS:Property DTS:Name="CreationName"></DTS:Property>
  <DTS:VariableValue DTS:DataType="8">
E:\BOOKSHARE\BOOKS\SSIS\SSIS_R2\SAMPLES\S21-Advanced</DTS:VariableValue>
  </DTS:Variable>
  <DTS:Variable>
  <DTS:Property DTS:Name="Expression"></DTS:Property>
  <DTS:Property DTS:Name="EvaluateAsExpression">0</DTS:Property>
  <DTS:Property DTS:Name="Namespace">SAMPLES</DTS:Property>
  <DTS:Property DTS:Name="ReadOnly">0</DTS:Property>
  <DTS:Property DTS:Name="RaiseChangedEvent">0</DTS:Property>
  <DTS:Property DTS:Name="IncludeInDebugDump">2345</DTS:Property>
  <DTS:Property DTS:Name="ObjectName">ROOTWD</DTS:Property>
  <DTS:Property DTS:Name="DTSID">{3BD365BA-FE06-4B5A-8100-69F27C71B74E}
  </DTS:Property>
  <DTS:Property DTS:Name="Description"></DTS:Property>
  <DTS:Property DTS:Name="CreationName"></DTS:Property>
  <DTS:VariableValue DTS:DataType="8">
  E:\BOOKSHARE\BOOKS\SSIS\SSIS_R2\SAMPLES</DTS:VariableValue>
  </DTS:Variable>
  <DTS:Variable>
  <DTS:Property DTS:Name="Expression"></DTS:Property>
  <DTS:Property DTS:Name="EvaluateAsExpression">0</DTS:Property>
  <DTS:Property DTS:Name="Namespace">SAMPLES</DTS:Property>
  <DTS:Property DTS:Name="ReadOnly">0</DTS:Property>
  <DTS:Property DTS:Name="RaiseChangedEvent">0</DTS:Property>
  <DTS:Property DTS:Name="IncludeInDebugDump">2345</DTS:Property>
  <DTS:Property DTS:Name="ObjectName">SAMPLESUBFOLDER</DTS:Property>
  <DTS:Property DTS:Name="DTSID">{6E7FB8C5-7F98-454E-87E0-D9BF0D0E06AD}
  </DTS:Property>
  <DTS:Property DTS:Name="Description"></DTS:Property>
  <DTS:Property DTS:Name="CreationName"></DTS:Property>
  <DTS:VariableValue DTS:DataType="8">S21-Advanced</DTS:VariableValue>
  </DTS:Variable>
  <DTS:Variable>
  <DTS:Property DTS:Name="Expression"></DTS:Property>
  <DTS:Property DTS:Name="EvaluateAsExpression">0</DTS:Property>
  <DTS:Property DTS:Name="Namespace">SAMPLES</DTS:Property>
  <DTS:Property DTS:Name="ReadOnly">0</DTS:Property>
  <DTS:Property DTS:Name="RaiseChangedEvent">0</DTS:Property>
  <DTS:Property DTS:Name="IncludeInDebugDump">2345</DTS:Property>
  <DTS:Property DTS:Name="ObjectName">SERVERNAME</DTS:Property>
  <DTS:Property DTS:Name="DTSID">{5F9998D0-186D-4C44-A949-66C8477A3CE7}
  </DTS:Property>
  <DTS:Property DTS:Name="Description"></DTS:Property>
  <DTS:Property DTS:Name="CreationName"></DTS:Property>
  <DTS:VariableValue DTS:DataType="8"></DTS:VariableValue>
  </DTS:Variable>
  <DTS:Variable>
  <DTS:Property DTS:Name="Expression"></DTS:Property>
  <DTS:Property DTS:Name="EvaluateAsExpression">0</DTS:Property>
  <DTS:Property DTS:Name="Namespace">SAMPLES</DTS:Property>
  <DTS:Property DTS:Name="ReadOnly">0</DTS:Property>

```

```

<DTS:Property DTS:Name="RaiseChangedEvent">0</DTS:Property>
<DTS:Property DTS:Name="IncludeInDebugDump">2345</DTS:Property>
<DTS:Property DTS:Name="ObjectName">WORKINGFOLDER</DTS:Property>
<DTS:Property DTS:Name="DTSID">{DC4065D8-A163-4893-BE71-FB0D146F3BA8}
</DTS:Property>
<DTS:Property DTS:Name="Description"></DTS:Property>
<DTS:Property DTS:Name="CreationName"></DTS:Property>
<DTS:VariableValue DTS:DataType="8">
E:\BOOKSHARE\BOOKS\SSIS\SSIS_R2\SAMPLES\SCRATCH</DTS:VariableValue>
</DTS:Variable>
<DTS:LoggingOptions>
  <DTS:Property DTS:Name="LoggingMode">0</DTS:Property>
  <DTS:Property DTS:Name="FilterKind">1</DTS:Property>
  <DTS:Property DTS:Name="EventFilter" DTS:DataType="8"></DTS:Property>
</DTS:LoggingOptions>
<DTS:Executable DTS:ExecutableType="SSIS.Pipeline.2">
  <DTS:Property DTS:Name="ExecutionLocation">0</DTS:Property>
  <DTS:Property DTS:Name="ExecutionAddress"></DTS:Property>
  <DTS:Property DTS:Name="TaskContact">
Performs high-performance data extraction, transformation and loading;Microsoft Corporation;
Microsoft SQL Server v9; (C) 2004 Microsoft Corporation; All Rights
Reserved;http://www.microsoft.com/sql/support/default.asp;1
</DTS:Property>
  <DTS:Property DTS:Name="ForceExecValue">0</DTS:Property>
  <DTS:Property DTS:Name="ExecValue" DTS:DataType="3">0</DTS:Property>
  <DTS:Property DTS:Name="ForceExecutionResult">-1</DTS:Property>
  <DTS:Property DTS:Name="Disabled">0</DTS:Property>
  <DTS:Property DTS:Name="FailPackageOnFailure">0</DTS:Property>
  <DTS:Property DTS:Name="FailParentOnFailure">0</DTS:Property>
  <DTS:Property DTS:Name="MaxErrorCount">1</DTS:Property>
  <DTS:Property DTS:Name="ISOLevel">1048576</DTS:Property>
  <DTS:Property DTS:Name="LocaleID">-1</DTS:Property>
  <DTS:Property DTS:Name="TransactionOption">1</DTS:Property>
  <DTS:Property DTS:Name="DelayValidation">0</DTS:Property>
  <DTS:Property DTS:Name="ObjectName">Data Flow Task</DTS:Property>
  <DTS:Property DTS:Name="DTSID">{7FAA584E-2F45-4786-8410-8E97F54B0E8D}
</DTS:Property>
  <DTS:Property DTS:Name="Description">Data Flow Task</DTS:Property>
  <DTS:Property DTS:Name="CreationName">SSIS.Pipeline.2</DTS:Property>
  <DTS:Property DTS:Name="DisableEventHandlers">0</DTS:Property>
  <DTS:LoggingOptions>
    <DTS:Property DTS:Name="LoggingMode">0</DTS:Property>
    <DTS:Property DTS:Name="FilterKind">1</DTS:Property>
    <DTS:Property DTS:Name="EventFilter" DTS:DataType="8"></DTS:Property>
  </DTS:LoggingOptions>
  <DTS:ObjectData>
    <pipeline id="0" name="pipelineXml" description="pipelineXml"
      defaultBufferMaxRows="10000" engineThreads="5"
      defaultBufferSize="10485760" BLOBTempStoragePath=""
      bufferTempStoragePath="" runInOptimizedMode="false">
      <components>
        <component id="3728" name="New Contact Names"
          componentClassID="{5ACD952A-F16A-41D8-A681-713640837664}"
          description="Flat File Source" localeId="1033"
          usesDispositions="true" validateExternalMetadata="True"
          version="1" pipelineVersion="0"
          contactInfo=
"Flat File Source;Microsoft Corporation;Microsoft SqlServer v9; (C) 2005 Microsoft
Corporation; All Rights Reserved; http://www.microsoft.com/sql/support;1">
          <properties>
            <property id="3734" name="RetainNulls"
              dataType="System.Boolean" state="default"
              isArray="false" description=
"Specifies whether zero-length columns are treated as null."
              typeConverter="" UITypeEditor="" containsID="false"
              expressionType="None">>false</property>
            <property id="3735" name="FileNameColumnName"
              dataType="System.String" state="default"
              isArray="false" description=

```

"Specifies the name of an output column containing the file name. If no name is specified, no output column containing the file name will be generated."

```
        typeConverter="" UITypeEditor=""
        containsID="false" expressionType="None"></property>
</properties>
<connections>
  <connection id="3733" name="FlatFileConnection"
    description="" connectionManagerID=
      "{E97F2191-17D8-400B-9EE6-7823482A958C}"/>
</connections>
<outputs>
  <output id="3729" name="Flat File Source Output"
    description="" exclusionGroup="0"
    synchronousInputId="0" deleteOutputOnPathDetached="false"
    hasSideEffects="false" dangling="false" isErrorOut="false"
    isSorted="false" errorOrTruncationOperation=""
    errorRowDisposition="NotUsed"
    truncationRowDisposition="NotUsed">
    <outputColumns>
      <outputColumn id="3745" name="FirstName" description=""
        lineageId="3745" precision="0" scale="0" length="50"
        dataType="wstr" codePage="0" sortKeyPosition="0"
        comparisonFlags="0" specialFlags="0"
        errorOrTruncationOperation="Conversion"
        errorRowDisposition="FailComponent"
        truncationRowDisposition="FailComponent"
        externalMetadataColumnId="3744" mappedColumnId="0">
        <properties>
          <property id="3746" name="FastParse"
            dataType="System.Boolean" state="default"
            isArray="false" description="
              "Indicates whether the column uses the faster, locale-neutral parsing routines."
            typeConverter="" UITypeEditor="" containsID="false"
            expressionType="None">false</property>
        </properties>
      </outputColumn>
      <outputColumn id="3748" name="LastName" description=""
        lineageId="3748" precision="0" scale="0"
        length="50" dataType="wstr" codePage="0"
        sortKeyPosition="0" comparisonFlags="0"
        specialFlags="0" errorOrTruncationOperation="Conversion"
        errorRowDisposition="FailComponent"
        truncationRowDisposition="FailComponent"
        externalMetadataColumnId="3747" mappedColumnId="0">
        <properties>
          <property id="3749" name="FastParse"
            dataType="System.Boolean" state="default"
            isArray="false" description="
              "Indicates whether the column uses the faster, locale-neutral parsing routines."
            typeConverter="" UITypeEditor="" containsID="false"
            expressionType="None">false</property>
        </properties>
      </outputColumn>
    </outputColumns>
    <externalMetadataColumns isUsed="True">
      <externalMetadataColumn id="3744" name="FirstName"
        description="" precision="0" scale="0" length="50"
        dataType="str" codePage="1252" mappedColumnId="0"/>
      <externalMetadataColumn id="3747" name="LastName"
        description="" precision="0" scale="0" length="50"
        dataType="str" codePage="1252" mappedColumnId="0"/>
    </externalMetadataColumns>
  </output>
  <output id="3730" name="Flat File Source Error Output"
    description="" exclusionGroup="0" synchronousInputId="0"
    deleteOutputOnPathDetached="false" hasSideEffects="false"
    dangling="false" isErrorOut="true" isSorted="false"
    errorOrTruncationOperation="" errorRowDisposition="NotUsed"
    truncationRowDisposition="NotUsed">
```

```

<outputColumns>
  <outputColumn id="3750" name=
    "Flat File Source Error Output Column"
    description="Flat File Source Error Output Column"
    lineageId="3750" precision="0" scale="0" length="0"
    dataType="text" codePage="1252" sortKeyPosition="0"
    comparisonFlags="0" specialFlags="0"
    errorOrTruncationOperation=""
    errorRowDisposition="NotUsed"
    truncationRowDisposition="NotUsed"
    externalMetadataColumnId="0"
    mappedColumnId="0"/>
  <outputColumn id="3731" name="ErrorCode" description=""
    lineageId="3731" precision="0" scale="0"
    length="0" dataType="i4" codePage="0"
    sortKeyPosition="0" comparisonFlags="0"
    specialFlags="1" errorOrTruncationOperation=""
    errorRowDisposition="NotUsed"
    truncationRowDisposition="NotUsed"
    externalMetadataColumnId="0"
    mappedColumnId="0"/>
  <outputColumn id="3732" name="ErrorColumn" description=""
    lineageId="3732" precision="0" scale="0"
    length="0" dataType="i4" codePage="0"
    sortKeyPosition="0" comparisonFlags="0"
    specialFlags="2" errorOrTruncationOperation=""
    errorRowDisposition="NotUsed"
    truncationRowDisposition="NotUsed"
    externalMetadataColumnId="0"
    mappedColumnId="0"/>
</outputColumns>
<externalMetadataColumns isUsed="False"/>
</output>
</outputs>
</component>
<component id="6980" name="Multicast" componentClassID=
  "{1ACA4459-ACE0-496F-814A-8611F9C27E23}"
  description="Creates copies of a dataset."
  localeId="-1" usesDispositions="false"
  validateExternalMetadata="True" version="0"
  pipelineVersion="0" contactInfo=
  "Multicast;Microsoft Corporation;Microsoft SqlServer v9; (C) 2005 Microsoft Corporation; All
  Rights Reserved; http://www.microsoft.com/sql/support;0">
  <inputs>
    <input id="6981" name="Multicast Input 1" description=""
      hasSideEffects="false" dangling="false"
      errorOrTruncationOperation=""
      errorRowDisposition="NotUsed"
      truncationRowDisposition="NotUsed">
      <externalMetadataColumns isUsed="False"/>
    </input>
  </inputs>
  <outputs>
    <output id="6982" name="Multicast Output 1" description=""
      exclusionGroup="0" synchronousInputId="6981"
      deleteOutputOnPathDetached="true" hasSideEffects=
      "false" dangling="true" isErrorOut="false"
      isSorted="false" errorOrTruncationOperation=""
      errorRowDisposition="NotUsed"
      truncationRowDisposition="NotUsed">
      <externalMetadataColumns isUsed="False"/>
    </output>
  </outputs>
</component>
<component id="7042" name="Multicast 1" componentClassID=
  "{1ACA4459-ACE0-496F-814A-8611F9C27E23}"
  description="Creates copies of a dataset."
  localeId="-1" usesDispositions="false"
  validateExternalMetadata="True" version="0"

```

```

        pipelineVersion="0" contactInfo=
"Multicast;Microsoft Corporation;Microsoft SqlServer v9; (C) 2005 Microsoft Corporation; All
Rights Reserved; http://www.microsoft.com/sql/support;0">
    <inputs>
        <input id="7043" name="Multicast Input 1" description=""
            hasSideEffects="false" dangling="false"
            errorOrTruncationOperation=""
            errorRowDisposition="NotUsed"
            truncationRowDisposition="NotUsed">
            <externalMetadataColumns isUsed="False"/>
        </input>
    </inputs>
    <outputs>
        <output id="7988" name="Multicast Output 2" description=""
            exclusionGroup="0" synchronousInputId="7043"
            deleteOutputOnPathDetached="true" hasSideEffects="false"
            dangling="true" isErrorOut="false" isSorted="false"
            errorOrTruncationOperation="" errorRowDisposition="NotUsed"
            truncationRowDisposition="NotUsed">
            <externalMetadataColumns isUsed="False"/>
        </output>
    </outputs>
</component>
<component id="6817" name="Lookup" componentClassID=
    "{27648839-180F-45E6-838D-AFF53DF682D2}"
description="Looks up values in a reference dataset by using exact matching."
    localeId="-1" usesDispositions="true"
    validateExternalMetadata="True" version="5"
    pipelineVersion="0" contactInfo=
"Lookup;Microsoft Corporation;Microsoft SqlServer v9; (C) 2005 Microsoft Corporation; All
Rights Reserved; http://www.microsoft.com/sql/support;4">
    <properties>
        <property id="6820" name="SqlCommand"
            dataType="System.String" state="default"
            isArray="false" description=
"Specifies the SQL statement that generates the lookup table."
            typeConverter="" UITypeEditor=
"Microsoft.DataTransformationServices.Controls.ModalMultilineStringEditor,
Microsoft.DataTransformationServices.Controls, Version=10.0.0.0, Culture=neutral,
PublicKeyToken=89845dcd8080cc91"
            containsID="false" expressionType="Notify">select * from
[Person].[Contact]</property>
        <property id="6821" name="SqlCommandParam"
            dataType="System.String" state="default"
            isArray="false" description=
"Specifies a SQL statement that uses parameters to generate the lookup table."
            typeConverter="" UITypeEditor="" containsID="false"
            expressionType="Notify">
            select * from (select * from [Person].[Contact]) [refTable]
            where [refTable].[FirstName] = ? and [refTable].[LastName] = ?
        </property>
        <property id="6823" name="CacheType" dataType="System.Int32"
            state="default" isArray="false" description=
"Specifies the cache type of the lookup table."
            typeConverter="CacheType" UITypeEditor=""
            containsID="false" expressionType="None">1</property>
        <property id="6824" name="MaxMemoryUsage"
            dataType="System.Int32" state="default"
            isArray="false" description=
"Maximum Memory Usage for Reference Cache on a 32 bit platform."
            typeConverter="" UITypeEditor="" containsID="false"
            expressionType="None">25</property>
        <property id="6825" name="MaxMemoryUsage64"
            dataType="System.Int64" state="default"
            isArray="false" description=
"Maximum Memory Usage for Reference Cache on a 64 bit platform."
            typeConverter="" UITypeEditor="" containsID="false"
            expressionType="None">25</property>
        <property id="6826" name="ReferenceMetadataXml"

```

```

        dataType="System.String" state="default"
        isArray="false" description=
        "Indicates whether to reference metadata in an XML format."
        typeConverter="" UITypeEditor="" containsID="false"
        expressionType="None">
<!--referenceMetadata--><!--referenceColumns--><!--referenceColumn name="ContactID"
dataType="DT_I4" length="0" precision="0" scale="0" codePage="0"/><!--referenceColumn
name="NameStyle" dataType="DT_BOOL" length="0" precision="0" scale="0"
codePage="0"/><!--referenceColumn name="Title" dataType="DT_WSTR" length="8" precision="0"
scale="0" codePage="0"/><!--referenceColumn name="FirstName" dataType="DT_WSTR"
length="50" precision="0" scale="0" codePage="0"/><!--referenceColumn name="MiddleName"
dataType="DT_WSTR" length="50" precision="0" scale="0" codePage="0"/><!--referenceColumn
name="LastName" dataType="DT_WSTR" length="50" precision="0" scale="0"
codePage="0"/><!--referenceColumn name="Suffix" dataType="DT_WSTR" length="10"
precision="0" scale="0" codePage="0"/><!--referenceColumn name="EmailAddress"
dataType="DT_WSTR" length="50" precision="0" scale="0" codePage="0"/><!--referenceColumn
name="EmailPromotion" dataType="DT_I4" length="0" precision="0" scale="0"
codePage="0"/><!--referenceColumn name="Phone" dataType="DT_WSTR" length="25"
precision="0" scale="0" codePage="0"/><!--referenceColumn name="PasswordHash"
dataType="DT_STR" length="128" precision="0" scale="0"
codePage="1252"/><!--referenceColumn name="PasswordSalt" dataType="DT_STR" length="10"
precision="0" scale="0" codePage="1252"/><!--referenceColumn name="AdditionalContactInfo"
dataType="DT_NTEXT" length="0" precision="0" scale="0" codePage="0"/><!--referenceColumn
name="rowguid" dataType="DT_GUID" length="0" precision="0" scale="0"
codePage="0"/><!--referenceColumn name="ModifiedDate" dataType="DT_DBTIMESTAMP" length="0"
precision="0" scale="0" codePage="0"/><!--referenceColumns--><!--referenceMetadata-->
</property>
<property id="6827" name="ParameterMap"
dataType="System.String" state="default"
isArray="false" description=
"Specifies the list of lineage identifiers that map to the parameters that the SQL statement
in the SQLCommand property uses. Entries in the list are separated by semicolons."
typeConverter="" UITypeEditor="" containsID="true"
expressionType="None">#3745;#3748;</property>
<property id="6828" name="DefaultCodePage"
dataType="System.Int32" state="default"
isArray="false" description=
"Specifies the column code page to use when code page information is unavailable from the
data source."
typeConverter="" UITypeEditor="" containsID="false"
expressionType="None">1252</property>
<property id="7989" name="ConnectionType"
dataType="System.Int32" state="default"
isArray="false" description=
"Specifies the type of connection used to access the reference dataset."
typeConverter="LookupConnectionType" UITypeEditor=""
containsID="false" expressionType="None">0</property>
<property id="7990" name="NoMatchBehavior"
dataType="System.Int32" state="default"
isArray="false" description=
"Specifies how the Lookup transformation handles rows without matching entries in the
reference data set."
typeConverter="LookupNoMatchBehavior"
UITypeEditor="" containsID="false"
expressionType="None">0</property>
<property id="7991" name="NoMatchCachePercentage"
dataType="System.Int32" state="default"
isArray="false" description=
"Specifies the percentage of the cache that is allocated for rows with no matching entries in
the reference dataset."
typeConverter="" UITypeEditor="" containsID="false"
expressionType="None">0</property>
</properties>
<connections>
<connection id="6822" name="OleDbConnection" description=
"Connection manager used to access lookup data."
connectionManagerID="{FAFAC1E8-81D4-4E0D-A5A9-ABAD9BF38826}"/>
</connections>
<inputs>

```

```

<input id="6818" name="Lookup Input" description=""
  hasSideEffects="false" dangling="false"
  errorOrTruncationOperation=""
  errorRowDisposition="NotUsed"
  truncationRowDisposition="NotUsed">
  <inputColumns>
    <inputColumn id="6852" name="" description=""
      lineageId="3745" usageType="readOnly"
      errorOrTruncationOperation=""
      errorRowDisposition="NotUsed"
      truncationRowDisposition="NotUsed"
      externalMetadataColumnId="0"
      mappedColumnId="0">
      <properties>
        <property id="6853" name="JoinToReferenceColumn"
          dataType="System.String" state="default"
          isArray="false" description=
"Specifies the column in the reference table that a column joins."
          typeConverter="" UITypeEditor=""
          containsID="false" expressionType="None">
          FirstName</property>
        <property id="6854" name="CopyFromReferenceColumn"
          dataType="System.Null" state="default"
          isArray="false" description=
"Specifies the column in the reference table from which a column is copied."
          typeConverter="" UITypeEditor=""
          containsID="false" expressionType="None"/>
      </properties>
    </inputColumn>
    <inputColumn id="6855" name="" description=""
      lineageId="3748" usageType="readOnly"
      errorOrTruncationOperation=""
      errorRowDisposition="NotUsed"
      truncationRowDisposition="NotUsed"
      externalMetadataColumnId="0"
      mappedColumnId="0">
      <properties>
        <property id="6856" name="JoinToReferenceColumn"
          dataType="System.String" state="default"
          isArray="false" description=
"Specifies the column in the reference table that a column joins."
          typeConverter="" UITypeEditor=""
          containsID="false" expressionType="None">
          LastName</property>
        <property id="6857" name="CopyFromReferenceColumn"
          dataType="System.Null" state="default"
          isArray="false" description=
"Specifies the column in the reference table from which a column is copied."
          typeConverter="" UITypeEditor=""
          containsID="false" expressionType="None"/>
      </properties>
    </inputColumn>
  </inputColumns>
  <externalMetadataColumns isUsed="False"/>
</input>
</inputs>
<outputs>
  <output id="6819" name="Lookup Match Output" description=""
    exclusionGroup="1" synchronousInputId="6818"
    deleteOutputOnPathDetached="false"
    hasSideEffects="false" dangling="false"
    isErrorOut="false" isSorted="false"
    errorOrTruncationOperation="Lookup"
    errorRowDisposition="RedirectRow"
    truncationRowDisposition="NotUsed">
  <outputColumns>
    <outputColumn id="6848" name="LUFirstName" description=""
      lineageId="6848" precision="0" scale="0"
      length="50" dataType="wstr" codePage="0"

```

```

        sortKeyPosition="0" comparisonFlags="0"
        specialFlags="0"
        errorOrTruncationOperation="Copy Column"
        errorRowDisposition="NotUsed"
        truncationRowDisposition="FailComponent"
        externalMetadataColumnId="0" mappedColumnId="0">
    <properties>
        <property id="6849" name="CopyFromReferenceColumn"
            dataType="System.String" state="default"
            isArray="false" description=
"Specifies the column in the reference table from which a column is copied."
            typeConverter="" UITypeEditor=""
            containsID="false" expressionType="None">
            FirstName</property>
        </properties>
    </outputColumn>
    <outputColumn id="6850" name="LULastName" description=""
        lineageId="6850" precision="0" scale="0"
        length="50" dataType="wstr" codePage="0"
        sortKeyPosition="0" comparisonFlags="0"
        specialFlags="0"
        errorOrTruncationOperation="Copy Column"
        errorRowDisposition="NotUsed"
        truncationRowDisposition="FailComponent"
        externalMetadataColumnId="0" mappedColumnId="0">
    <properties>
        <property id="6851" name="CopyFromReferenceColumn"
            dataType="System.String" state="default"
            isArray="false" description=
"Specifies the column in the reference table from which a column is copied."
            typeConverter="" UITypeEditor=""
            containsID="false" expressionType="None">
            LastName</property>
        </properties>
    </outputColumn>
    <outputColumn id="7071" name="NameStyle" description=""
        lineageId="7071" precision="0" scale="0"
        length="0" dataType="bool" codePage="0"
        sortKeyPosition="0" comparisonFlags="0"
        specialFlags="0"
        errorOrTruncationOperation="Copy Column"
        errorRowDisposition="NotUsed"
        truncationRowDisposition="FailComponent"
        externalMetadataColumnId="0" mappedColumnId="0">
    <properties>
        <property id="7072" name="CopyFromReferenceColumn"
            dataType="System.String" state="default"
            isArray="false" description=
"Specifies the column in the reference table from which a column is copied."
            typeConverter="" UITypeEditor=""
            containsID="false" expressionType="None">
            NameStyle</property>
        </properties>
    </outputColumn>
    <outputColumn id="7073" name="Title" description=""
        lineageId="7073" precision="0" scale="0"
        length="8" dataType="wstr" codePage="0"
        sortKeyPosition="0" comparisonFlags="0"
        specialFlags="0"
        errorOrTruncationOperation="Copy Column"
        errorRowDisposition="NotUsed"
        truncationRowDisposition="FailComponent"
        externalMetadataColumnId="0" mappedColumnId="0">
    <properties>
        <property id="7074" name="CopyFromReferenceColumn"
            dataType="System.String" state="default"
            isArray="false" description=
"Specifies the column in the reference table from which a column is copied."
            typeConverter="" UITypeEditor=""

```



```

        containsID="false" expressionType="None">
        Title</property>
    </properties>
</outputColumn>
<outputColumn id="7075" name="MiddleName" description=""
    lineageId="7075" precision="0" scale="0"
    length="50" dataType="wstr" codePage="0"
    sortKeyPosition="0" comparisonFlags="0"
    specialFlags="0"
    errorOrTruncationOperation="Copy Column"
    errorRowDisposition="NotUsed"
    truncationRowDisposition="FailComponent"
    externalMetadataColumnId="0" mappedColumnId="0">
    <properties>
        <property id="7076" name="CopyFromReferenceColumn"
            dataType="System.String" state="default"
            isArray="false" description="
"Specifies the column in the reference table from which a column is copied."
            typeConverter="" UITypeEditor=""
            containsID="false" expressionType="None">
            MiddleName</property>
        </properties>
    </outputColumn>
<outputColumn id="7077" name="Suffix" description=""
    lineageId="7077" precision="0" scale="0"
    length="10" dataType="wstr" codePage="0"
    sortKeyPosition="0" comparisonFlags="0"
    specialFlags="0"
    errorOrTruncationOperation="Copy Column"
    errorRowDisposition="NotUsed"
    truncationRowDisposition="FailComponent"
    externalMetadataColumnId="0" mappedColumnId="0">
    <properties>
        <property id="7078" name="CopyFromReferenceColumn"
            dataType="System.String" state="default"
            isArray="false" description="
"Specifies the column in the reference table from which a column is copied."
            typeConverter="" UITypeEditor=""
            containsID="false" expressionType="None">
            Suffix</property>
        </properties>
    </outputColumn>
<outputColumn id="7079" name="EmailAddress" description=""
    lineageId="7079" precision="0" scale="0"
    length="50" dataType="wstr" codePage="0"
    sortKeyPosition="0" comparisonFlags="0"
    specialFlags="0"
    errorOrTruncationOperation="Copy Column"
    errorRowDisposition="NotUsed"
    truncationRowDisposition="FailComponent"
    externalMetadataColumnId="0" mappedColumnId="0">
    <properties>
        <property id="7080" name="CopyFromReferenceColumn"
            dataType="System.String" state="default"
            isArray="false" description="
"Specifies the column in the reference table from which a column is copied."
            typeConverter="" UITypeEditor=""
            containsID="false" expressionType="None">
            EmailAddress</property>
        </properties>
    </outputColumn>
<outputColumn id="7081" name="EmailPromotion"
    description="" lineageId="7081"
    precision="0" scale="0" length="0"
    dataType="i4" codePage="0"
    sortKeyPosition="0" comparisonFlags="0"
    specialFlags="0"
    errorOrTruncationOperation="Copy Column"
    errorRowDisposition="NotUsed"

```

```

        truncationRowDisposition="FailComponent"
        externalMetadataColumnId="0" mappedColumnId="0">
    <properties>
        <property id="7082" name="CopyFromReferenceColumn"
            dataType="System.String" state="default"
            isArray="false" description="
"Specifies the column in the reference table from which a column is copied."
            typeConverter="" UITypeEditor=""
            containsID="false" expressionType="None">
            EmailPromotion</property>
        </properties>
    </outputColumn>
    <outputColumn id="7083" name="Phone" description=""
        lineageId="7083" precision="0" scale="0"
        length="25" dataType="wstr" codePage="0"
        sortKeyPosition="0" comparisonFlags="0"
        specialFlags="0" errorOrTruncationOperation="Copy Column"
        errorRowDisposition="NotUsed"
        truncationRowDisposition="FailComponent"
        externalMetadataColumnId="0" mappedColumnId="0">
    <properties>
        <property id="7084" name="CopyFromReferenceColumn"
            dataType="System.String" state="default"
            isArray="false" description="
"Specifies the column in the reference table from which a column is copied."
            typeConverter="" UITypeEditor=""
            containsID="false" expressionType="None">
            Phone</property>
        </properties>
    </outputColumn>
    <outputColumn id="7085" name="PasswordHash" description=""
        lineageId="7085" precision="0" scale="0"
        length="128" dataType="str" codePage="1252"
        sortKeyPosition="0" comparisonFlags="0"
        specialFlags="0"
        errorOrTruncationOperation="Copy Column"
        errorRowDisposition="NotUsed"
        truncationRowDisposition="FailComponent"
        externalMetadataColumnId="0" mappedColumnId="0">
    <properties>
        <property id="7086" name="CopyFromReferenceColumn"
            dataType="System.String" state="default"
            isArray="false" description="
"Specifies the column in the reference table from which a column is copied."
            typeConverter="" UITypeEditor=""
            containsID="false"
            expressionType="None">PasswordHash</property>
        </properties>
    </outputColumn>
    <outputColumn id="7087" name="PasswordSalt" description=""
        lineageId="7087" precision="0" scale="0"
        length="10" dataType="str" codePage="1252"
        sortKeyPosition="0" comparisonFlags="0"
        specialFlags="0"
        errorOrTruncationOperation="Copy Column"
        errorRowDisposition="NotUsed"
        truncationRowDisposition="FailComponent"
        externalMetadataColumnId="0" mappedColumnId="0">
    <properties>
        <property id="7088" name="CopyFromReferenceColumn"
            dataType="System.String" state="default"
            isArray="false" description="
"Specifies the column in the reference table from which a column is copied."
            typeConverter="" UITypeEditor=""
            containsID="false" expressionType="None">
            PasswordSalt</property>
        </properties>
    </outputColumn>
    <outputColumn id="7089" name="AdditionalContactInfo"

```

```

        description="" lineageId="7089" precision="0"
        scale="0" length="0" dataType="nText"
        codePage="0" sortKeyPosition="0"
        comparisonFlags="0" specialFlags="0"
        errorOrTruncationOperation="Copy Column"
        errorRowDisposition="NotUsed"
        truncationRowDisposition="FailComponent"
        externalMetadataColumnId="0" mappedColumnId="0">
<properties>
  <property id="7090" name="CopyFromReferenceColumn"
    dataType="System.String" state="default"
    isArray="false" description=
"Specifies the column in the reference table from which a column is copied."
    typeConverter="" UITypeEditor=""
    containsID="false" expressionType="None">
    AdditionalContactInfo</property>
</properties>
</outputColumn>
<outputColumn id="7091" name="rowguid" description=""
  lineageId="7091" precision="0" scale="0"
  length="0" dataType="guid" codePage="0"
  sortKeyPosition="0" comparisonFlags="0"
  specialFlags="0"
  errorOrTruncationOperation="Copy Column"
  errorRowDisposition="NotUsed"
  truncationRowDisposition="FailComponent"
  externalMetadataColumnId="0" mappedColumnId="0">
<properties>
  <property id="7092" name="CopyFromReferenceColumn"
    dataType="System.String" state="default"
    isArray="false" description=
"Specifies the column in the reference table from which a column is copied."
    typeConverter="" UITypeEditor=""
    containsID="false" expressionType="None">
    rowguid</property>
</properties>
</outputColumn>
<outputColumn id="7093" name="ModifiedDate" description=""
  lineageId="7093" precision="0" scale="0"
  length="0" dataType="dbTimeStamp"
  codePage="0" sortKeyPosition="0"
  comparisonFlags="0" specialFlags="0"
  errorOrTruncationOperation="Copy Column"
  errorRowDisposition="NotUsed"
  truncationRowDisposition="FailComponent"
  externalMetadataColumnId="0" mappedColumnId="0">
<properties>
  <property id="7094" name="CopyFromReferenceColumn"
    dataType="System.String" state="default"
    isArray="false" description=
"Specifies the column in the reference table from which a column is copied."
    typeConverter="" UITypeEditor=""
    containsID="false" expressionType="None">
    ModifiedDate</property>
</properties>
</outputColumn>
</outputColumns>
<externalMetadataColumns isUsed="False"/>
</output>
<output id="7992" name="Lookup No Match Output" description=
"The Lookup output that handles rows with no matching entries in the reference dataset. Use
this output when the NoMatchBehavior property is set to &quot;Send rows with no matching
entries to the no match output.&quot;"
  exclusionGroup="1" synchronousInputId="6818"
  deleteOutputOnPathDetached="false"
  hasSideEffects="false" dangling="false"
  isErrorOut="false" isSorted="false"
  errorOrTruncationOperation=""
  errorRowDisposition="NotUsed"

```

```

        truncationRowDisposition="NotUsed">
        <externalMetadataColumns isUsed="False"/>
    </output>
    <output id="6829" name="Lookup Error Output" description=""
        exclusionGroup="1" synchronousInputId="6818"
        deleteOutputOnPathDetached="false"
        hasSideEffects="false" dangling="false"
        isErrorOut="true" isSorted="false"
        errorOrTruncationOperation=""
        errorRowDisposition="NotUsed"
        truncationRowDisposition="NotUsed">
        <outputColumns>
            <outputColumn id="6830" name="ErrorCode" description=""
                lineageId="6830" precision="0" scale="0"
                length="0" dataType="i4" codePage="0"
                sortKeyPosition="0" comparisonFlags="0"
                specialFlags="1" errorOrTruncationOperation=""
                errorRowDisposition="NotUsed"
                truncationRowDisposition="NotUsed"
                externalMetadataColumnId="0" mappedColumnId="0"/>
            <outputColumn id="6831" name="ErrorColumn" description=""
                lineageId="6831" precision="0" scale="0"
                length="0" dataType="i4" codePage="0"
                sortKeyPosition="0" comparisonFlags="0"
                specialFlags="2" errorOrTruncationOperation=""
                errorRowDisposition="NotUsed"
                truncationRowDisposition="NotUsed"
                externalMetadataColumnId="0" mappedColumnId="0"/>
        </outputColumns>
        <externalMetadataColumns isUsed="False"/>
    </output>
</outputs>
</component>
<component id="6858" name="Fuzzy Lookup" componentClassID=
    "{5056651F-F227-4978-94DF-53CDF9E8CCB6}" description=
    "Looks up values in a reference dataset by using fuzzy matching."
    localeId="-1" usesDispositions="false"
    validateExternalMetadata="True" version="5"
    pipelineVersion="0" contactInfo=
    "Fuzzy Lookup;Microsoft Corporation;Microsoft SqlServer v9; (C) 2005 Microsoft Corporation;
    All Rights Reserved; http://www.microsoft.com/sql/support;5">
    <properties>
        <property id="6861" name="MatchIndexOptions"
            dataType="System.Int32" state="default"
            isArray="false" description=
            "Indicates whether to reuse an existing fuzzy-match index table or build a new one. The new
            index table can be temporary, persisted, or persisted and maintained."
            typeConverter="tcMatchIndexOptions"
            UITypeEditor="" containsID="false"
            expressionType="None">1</property>
        <property id="6862" name="MaxMemoryUsage"
            dataType="System.Null" state="default"
            isArray="false" description=
            "Specifies the maximum amount of memory (MB) that this instance of the Fuzzy Lookup
            transformation can use. If 0 is given, then the transform will dynamically adjust it's
            memory usage based upon it's requirements and available system memory."
            typeConverter="" UITypeEditor=""
            containsID="false" expressionType="Notify"/>
        <property id="6863" name="MatchIndexName"
            dataType="System.String" state="escaped"
            isArray="false" description=
            "Specifies the name of the fuzzy-match index table to be reused or the table name in which a
            newly generated fuzzy-match index table will be written."
            typeConverter="" UITypeEditor=""
            containsID="false" expressionType="None">
            ContactsMatchIndex</property>
        <property id="6864" name="ReferenceTableName"
            dataType="System.String" state="escaped"
            isArray="false" description=

```

"Specifies the name of the reference table or view against which to match incoming records."

```

    typeConverter="" UITypeEditor=""
    containsID="false" expressionType="None">
      _x005B_Person_x005D_._x005B_Contact_x005D_</property>
    <property id="6865" name="DropExistingMatchIndex"
      dataType="System.Int32" state="default"
      isArray="false" description=

```

"Indicates whether to drop an existing fuzzy-match index table if transformation is configured to generate a new table and a table with the same name already exists."

```

    typeConverter="" UITypeEditor="" containsID="false"
    expressionType="None">1</property>
    <property id="6866" name="CopyReferenceTable"
      dataType="System.Int32" state="default"
      isArray="false" description=

```

"Whether a copy of the reference table should be made for fuzzy match index construction and subsequent matching. It is strongly recommended that a copy always be made, otherwise unpredictable output may result if the contents of the reference table change during package execution (or between executions if reusing a fuzzy match index). If this property is set to false, the reference table must additionally have a clustered index built upon an integer identity column."

```

    typeConverter="" UITypeEditor=""
    containsID="false" expressionType="None">1
  </property>
  <property id="6867" name="MaxOutputMatchesPerInput"
    dataType="System.UInt32" state="default"
    isArray="false" description=

```

"Specifies the maximum number of fuzzy matches to return for an input record."

```

    typeConverter="" UITypeEditor="" containsID="false"
    expressionType="None">1</property>
    <property id="6868" name="MinSimilarity"
      dataType="System.Single" state="default"
      isArray="false" description=

```

"Specifies the minimum similarity score required for the match results that the transformation returns."

```

    typeConverter="" UITypeEditor=""
    containsID="false" expressionType="None">0.65
  </property>
  <property id="6869" name="Delimiters" dataType="System.String"
    state="escaped" isArray="false" description=
    "Specifies the set of white-space and punctuation characters used to
    separate fuzzy match fields into the words used for matching and scoring a fuzzy lookup."
    typeConverter="" UITypeEditor="" containsID="false"
    expressionType="None">_x0020_x0009_x000D_x000A_x002C_.x003B_-:
    _x0022_x0027_x0026_x002F_x005C_x0040_x0021_x003F_x0028_x0029_x003C_x003E_x005B_x
    005D_x007B_x007D_x007C_x0023_x002A_x005E_x0025_</property>
    <property id="6870" name="ReferenceMetadataXml"
      dataType="System.String" state="escaped"
      isArray="false" description=

```

"Specifies the metadata of the reference table in XML format."

```

    typeConverter="" UITypeEditor="" containsID="false"
    expressionType="None">
      x003C referenceMetadata x003E x003C referenceColumns x003E x003C referenceColumn x0020 nam
      e_x003D_x0022_ContactID_x0022_x0020_dataType_x003D_x0022_DT_I4_x0022_x0020_length_x003D_
      x0022_0_x0022_x0020_precision_x003D_x0022_0_x0022_x0020_scale_x003D_x0022_0_x0022_x0020
      codePage_x003D_x0022_0_x0022_x002F_x003E_x003C referenceColumn_x0020_name_x003D_x0022_Na
      meStyle_x0022_x0020_dataType_x003D_x0022_DT_BOOL_x0022_x0020_length_x003D_x0022_0_x0022_
      x0020_precision_x003D_x0022_0_x0022_x0020_scale_x003D_x0022_0_x0022_x0020_codePage_x003D_
      x0022_0_x0022_x002F_x003E_x003C referenceColumn_x0020_name_x003D_x0022 Title_x0022_x002
      0_dataType_x003D_x0022 DT_WSTR_x0022_x0020_length_x003D_x0022_8_x0022_x0020_precision_x00
      3D_x0022_0_x0022_x0020_scale_x003D_x0022_0_x0022_x0020_codePage_x003D_x0022_0_x0022_x00
      2F_x003E_x003C referenceColumn_x0020_name_x003D_x0022 FirstName_x0022_x0020_dataType_x003
      D_x0022 DT_WSTR_x0022_x0020_length_x003D_x0022_50_x0022_x0020_precision_x003D_x0022_0_x0
      022_x0020_scale_x003D_x0022_0_x0022_x0020_codePage_x003D_x0022_0_x0022_x002F_x003E_x00
      3C referenceColumn_x0020_name_x003D_x0022 MiddleName_x0022_x0020_dataType_x003D_x0022 DT_W
      STR_x0022_x0020_length_x003D_x0022_50_x0022_x0020_precision_x003D_x0022_0_x0022_x0020_sc
      ale_x003D_x0022_0_x0022_x0020_codePage_x003D_x0022_0_x0022_x002F_x003E_x003C referenceC
      olumn_x0020_name_x003D_x0022 LastName_x0022_x0020_dataType_x003D_x0022 DT_WSTR_x0022_x002
      0_length_x003D_x0022_50_x0022_x0020_precision_x003D_x0022_0_x0022_x0020_scale_x003D_x002
      2_0_x0022_x0020_codePage_x003D_x0022_0_x0022_x002F_x003E_x003C referenceColumn_x0020_nam

```

```

e_x003D_x0022_Suffix_x0022_x0020_dataType_x003D_x0022_DT_WSTR_x0022_x0020_length_x003D_x
0022_10_x0022_x0020_precision_x003D_x0022_0_x0022_x0020_scale_x003D_x0022_0_x0022_x0020
codePage_x003D_x0022_0_x0022_x002F_x003E_x003C_referenceColumn_x0020_name_x003D_x0022_Em
ailAddress_x0022_x0020_dataType_x003D_x0022_DT_WSTR_x0022_x0020_length_x003D_x0022_50_x00
22_x0020_precision_x003D_x0022_0_x0022_x0020_scale_x003D_x0022_0_x0022_x0020_codePage_x0
03D_x0022_0_x0022_x002F_x003E_x003C_referenceColumn_x0020_name_x003D_x0022_EmailPromotio
n_x0022_x0020_dataType_x003D_x0022_DT_I4_x0022_x0020_length_x003D_x0022_0_x0022_x0020_pr
ecision_x003D_x0022_0_x0022_x0020_scale_x003D_x0022_0_x0022_x0020_codePage_x003D_x0022_0
_x0022_x002F_x003E_x003C_referenceColumn_x0020_name_x003D_x0022_Phone_x0022_x0020_dataType
pe_x003D_x0022_DT_WSTR_x0022_x0020_length_x003D_x0022_25_x0022_x0020_precision_x003D_x00
22_0_x0022_x0020_scale_x003D_x0022_0_x0022_x0020_codePage_x003D_x0022_0_x0022_x002F_x00
3E_x003C_referenceColumn_x0020_name_x003D_x0022_PasswordHash_x0022_x0020_dataType_x003D_x
0022_DT_STR_x0022_x0020_length_x003D_x0022_40_x0022_x0020_precision_x003D_x0022_0_x0022
_x0020_scale_x003D_x0022_0_x0022_x0020_codePage_x003D_x0022_1252_x0022_x002F_x003E_x003C
_referenceColumn_x0020_name_x003D_x0022_PasswordSalt_x0022_x0020_dataType_x003D_x0022_DT_S
TR_x0022_x0020_length_x003D_x0022_10_x0022_x0020_precision_x003D_x0022_0_x0022_x0020_sca
le_x003D_x0022_0_x0022_x0020_codePage_x003D_x0022_1252_x0022_x002F_x003E_x003C_referenc
eColumn_x0020_name_x003D_x0022_AdditionalContactInfo_x0022_x0020_dataType_x003D_x0022_DT_N
TEXT_x0022_x0020_length_x003D_x0022_0_x0022_x0020_precision_x003D_x0022_0_x0022_x0020_sc
ale_x003D_x0022_0_x0022_x0020_codePage_x003D_x0022_0_x0022_x002F_x003E_x003C_referenc
olumn_x0020_name_x003D_x0022_rowguid_x0022_x0020_dataType_x003D_x0022_DT_GUID_x0022_x0020
_length_x003D_x0022_0_x0022_x0020_precision_x003D_x0022_0_x0022_x0020_scale_x003D_x0022
_0_x0022_x0020_codePage_x003D_x0022_0_x0022_x002F_x003E_x003C_referenceColumn_x0020_name
_x003D_x0022_ModifiedDate_x0022_x0020_dataType_x003D_x0022_DT_DBTIMESTAMP_x0022_x0020_leng
th_x003D_x0022_0_x0022_x0020_precision_x003D_x0022_0_x0022_x0020_scale_x003D_x0022_0_x00
22_x0020_codePage_x003D_x0022_0_x0022_x002F_x003E_x003C_x002F_referenceColumns_x003E_x
003C_x002F_referenceMetadata_x003E_x000D_x000A
</property>
<property id="6871" name="Exhaustive" dataType="System.Boolean"
state="default" isArray="false" description=
"If true, each input record will be directly compared against EVERY record in the reference
table. This may produce slightly better results, but will be extremely slow unless the
number of records in the reference table is very small. Note that the entire reference table
will be loaded into main memory if this option is enabled. This option is primarily intended
for debugging purposes and should be used with care."
typeConverter="" UITypeEditor=""
containsID="false" expressionType="None">false
</property>
<property id="6872" name="WarmCaches"
dataType="System.Boolean" state="default"
isArray="false" description=
"If true, Fuzzy Lookup will partially load the error-tolerant index and the reference table
into main memory before execution begins. This can greatly enhance performance if many input
rows are to be processed."
typeConverter="" UITypeEditor=""
containsID="false" expressionType="None">true
</property>
</properties>
<connections>
<connection id="6873" name="OleDbConnection" description=
"Microsoft SQL Server connection and database in which the fuzzy lookup reference table is
located and where the fuzzy match index table will be stored and accessed."
connectionManagerID="{FAFAC1E8-81D4-4E0D-A5A9-ABAD9BF38826}"/>
</connections>
<inputs>
<input id="6859" name="Fuzzy Lookup Input" description=""
hasSideEffects="false" dangling="false"
errorOrTruncationOperation=""
errorRowDisposition="NotUsed"
truncationRowDisposition="NotUsed">
<inputColumns>
<inputColumn id="6924" name="" description=""
lineageId="3745" usageType="readOnly"
errorOrTruncationOperation=""
errorRowDisposition="NotUsed"
truncationRowDisposition="NotUsed"
externalMetadataColumnId="0" mappedColumnId="0">
<properties>
<property id="6925" name="JoinToReferenceColumn"
dataType="System.String" state="escaped"

```

```

        isArray="false" description=
"Name of the reference table column with which the input column should be matched."
        typeConverter="" UITypeEditor=""
        containsID="false" expressionType="None">
        FirstName</property>
    <property id="6926" name="JoinType"
        dataType="System.Int32" state="default"
        isArray="false" description=
"Specifies whether the match is a fuzzy or an exact match."
        typeConverter="tcJoinType"
        UITypeEditor="" containsID="false"
        expressionType="None">2</property>
    <property id="6927" name="MinSimilarity"
        dataType="System.Single" state="default"
        isArray="false" description=
"Specifies the minimum textual similarity required between input and fuzzy matched records on
values in this particular join column. Must be a floating point value between 0.0 and 1.0."
        typeConverter="" UITypeEditor=""
        containsID="false" expressionType="None">0
    </property>
    <property id="6928" name="FuzzyComparisonFlags"
        dataType="System.Int32" state="default"
        isArray="false" description=
"Specifies the comparison options for character data. The options are those supported by the
FoldString function."
        typeConverter="tcComparisonFlags"
        UITypeEditor="" containsID="false"
        expressionType="None">1</property>
    <property id="6929" name="FuzzyComparisonFlagsEx"
        dataType="System.UInt32" state="default"
        isArray="false" description=
"Flags to FoldString that should be used when comparing whether two strings are equivalent."
        typeConverter="tcComparisonFlagsEx"
        UITypeEditor="" containsID="false"
        expressionType="None">0</property>
</properties>
</inputColumn>
<inputColumn id="6934" name="" description=""
    lineageId="3748" usageType="readOnly"
    errorOrTruncationOperation=""
    errorRowDisposition="NotUsed"
    truncationRowDisposition="NotUsed"
    externalMetadataColumnId="0" mappedColumnId="0">
<properties>
    <property id="6935" name="JoinToReferenceColumn"
        dataType="System.String" state="escaped"
        isArray="false" description=
"Name of the reference table column with which the input column should be matched."
        typeConverter="" UITypeEditor=""
        containsID="false" expressionType="None">
        LastName</property>
    <property id="6936" name="JoinType"
        dataType="System.Int32" state="default"
        isArray="false" description=
"Specifies whether the match is a fuzzy or an exact match."
        typeConverter="tcJoinType" UITypeEditor=""
        containsID="false" expressionType="None">2
    </property>
    <property id="6937" name="MinSimilarity"
        dataType="System.Single" state="default"
        isArray="false" description=
"Specifies the minimum textual similarity required between input and fuzzy matched records on
values in this particular join column. Must be a floating point value between 0.0 and 1.0."
        typeConverter="" UITypeEditor=""
        containsID="false"
        expressionType="None">0</property>
    <property id="6938" name="FuzzyComparisonFlags"
        dataType="System.Int32" state="default"
        isArray="false" description=

```

```

"Specifies the comparison options for character data. The options are those supported by the
FoldString function." typeConverter="tcComparisonFlags"
    UITypeEditor="" containsID="false"
    expressionType="None">1</property>
  <property id="6939" name="FuzzyComparisonFlagsEx"
    dataType="System.UInt32" state="default"
    isArray="false" description=
"Flags to FoldString that should be used when comparing whether two strings are equivalent."
    typeConverter="tcComparisonFlagsEx"
    UITypeEditor="" containsID="false"
    expressionType="None">0</property>
</properties>
</inputColumn>
</inputColumns>
<externalMetadataColumns isUsed="False"/>
</input>
</inputs>
<outputs>
  <output id="6860" name="Fuzzy Lookup Output" description=""
    exclusionGroup="0" synchronousInputId="0"
    deleteOutputOnPathDetached="false"
    hasSideEffects="false" dangling="false"
    isErrorOut="false" isSorted="false"
    errorOrTruncationOperation=""
    errorRowDisposition="NotUsed"
    truncationRowDisposition="NotUsed">
  <outputColumns>
    <outputColumn id="6930" name="FirstName" description=""
      lineageId="6930" precision="0" scale="0"
      length="50" dataType="wstr" codePage="0"
      sortKeyPosition="0" comparisonFlags="0"
      specialFlags="0" errorOrTruncationOperation=""
      errorRowDisposition="NotUsed"
      truncationRowDisposition="NotUsed"
      externalMetadataColumnId="0" mappedColumnId="0">
    <properties>
      <property id="6931" name="CopyFromReferenceColumn"
        dataType="System.Null" state="escaped"
        isArray="false" description=
"Specifies the reference table column that is copied to the output for each match result."
        typeConverter="" UITypeEditor=""
        containsID="false" expressionType="None"/>
      <property id="6932" name="SourceInputColumnLineageID"
        dataType="System.Int32" state="default"
        isArray="false" description=
"Specifies the lineage identifier of the input column from which to copy to this output
column for each match."
        typeConverter="" UITypeEditor=""
        containsID="true" expressionType="None">
3745</property>
      <property id="6933" name="ColumnType"
        dataType="System.Int32" state="default"
        isArray="false" description=
"Specifies whether the column is used to indicate confidence or similarity."
        typeConverter="tcColumnType" UITypeEditor=""
        containsID="false" expressionType="None">0
    </property>
  </properties>
</outputColumn>
<outputColumn id="6940" name="LastName" description=""
  lineageId="6940" precision="0" scale="0"
  length="50" dataType="wstr" codePage="0"
  sortKeyPosition="0" comparisonFlags="0"
  specialFlags="0" errorOrTruncationOperation=""
  errorRowDisposition="NotUsed"
  truncationRowDisposition="NotUsed"
  externalMetadataColumnId="0" mappedColumnId="0">
<properties>
  <property id="6941" name="CopyFromReferenceColumn"

```



```

        dataType="System.Null" state="escaped"
        isArray="false" description=
"Specifies the reference table column that is copied to the output for each match result."
        typeConverter="" UITypeEditor=""
        containsID="false" expressionType="None"/>
    <property id="6942" name="SourceInputColumnLineageID"
        dataType="System.Int32" state="default"
        isArray="false" description=
"Specifies the lineage identifier of the input column from which to copy to this output
column for each match."
        typeConverter="" UITypeEditor=""
        containsID="true" expressionType="None">
3748</property>
    <property id="6943" name="ColumnType"
        dataType="System.Int32" state="default"
        isArray="false" description=
"Specifies whether the column is used to indicate confidence or similarity."
        typeConverter="tcColumnType" UITypeEditor=""
        containsID="false" expressionType="None">0
    </property>
</properties>
</outputColumn>
<outputColumn id="6964" name="FLFirstName" description=""
        lineageId="6964" precision="0" scale="0"
        length="50" dataType="wstr" codePage="0"
        sortKeyPosition="0" comparisonFlags="0"
        specialFlags="0" errorOrTruncationOperation=""
        errorRowDisposition="NotUsed"
        truncationRowDisposition="NotUsed"
        externalMetadataColumnId="0"
        mappedColumnId="0">
    <properties>
    <property id="6965" name="CopyFromReferenceColumn"
        dataType="System.String" state="escaped"
        isArray="false" description=
"Specifies the reference table column that is copied to the output for each match result."
        typeConverter="" UITypeEditor=""
        containsID="false" expressionType="None">
        FirstName</property>
    <property id="6966" name="SourceInputColumnLineageID"
        dataType="System.Null" state="default"
        isArray="false" description=
"Specifies the lineage identifier of the input column from which to copy to this output
column for each match."
        typeConverter="" UITypeEditor=""
        containsID="true" expressionType="None"/>
    <property id="6967" name="ColumnType"
        dataType="System.Int32" state="default"
        isArray="false" description=
"Specifies whether the column is used to indicate confidence or similarity."
        typeConverter="tcColumnType" UITypeEditor=""
        containsID="false" expressionType="None">0
    </property>
</properties>
</outputColumn>
<outputColumn id="6968" name="FLLastName" description=""
        lineageId="6968" precision="0" scale="0"
        length="50" dataType="wstr" codePage="0"
        sortKeyPosition="0" comparisonFlags="0"
        specialFlags="0" errorOrTruncationOperation=""
        errorRowDisposition="NotUsed"
        truncationRowDisposition="NotUsed"
        externalMetadataColumnId="0" mappedColumnId="0">
    <properties>
    <property id="6969" name="CopyFromReferenceColumn"
        dataType="System.String" state="escaped"
        isArray="false" description=
"Specifies the reference table column that is copied to the output for each match result."
        typeConverter="" UITypeEditor=""

```

```

        containsID="false" expressionType="None">
        LastName</property>
    <property id="6970" name="SourceInputColumnLineageID"
        dataType="System.Null" state="default"
        isArray="false" description=
"Specifies the lineage identifier of the input column from which to copy to this output
column for each match."
        typeConverter="" UITypeEditor=""
        containsID="true" expressionType="None"/>
    <property id="6971" name="ColumnType"
        dataType="System.Int32" state="default"
        isArray="false" description=
"Specifies whether the column is used to indicate confidence or similarity."
        typeConverter="tcColumnType" UITypeEditor=""
        containsID="false" expressionType="None">0
    </property>
</properties>
</outputColumn>
<outputColumn id="6874" name=" Similarity" description=""
    lineageId="6874" precision="0" scale="0"
    length="0" dataType="r4" codePage="0"
    sortKeyPosition="0" comparisonFlags="0"
    specialFlags="0" errorOrTruncationOperation=""
    errorRowDisposition="NotUsed"
    truncationRowDisposition="NotUsed"
    externalMetadataColumnId="0" mappedColumnId="0">
    <properties>
        <property id="6875" name="ColumnType"
            dataType="System.Int32" state="default"
            isArray="false" description=
"Specifies whether the column is used to indicate confidence or similarity."
            typeConverter="tcColumnType"
            UITypeEditor="" containsID="false"
            expressionType="None">1</property>
    </properties>
</outputColumn>
<outputColumn id="6876" name=" Confidence" description=""
    lineageId="6876" precision="0" scale="0"
    length="0" dataType="r4" codePage="0"
    sortKeyPosition="0" comparisonFlags="0"
    specialFlags="0" errorOrTruncationOperation=""
    errorRowDisposition="NotUsed"
    truncationRowDisposition="NotUsed"
    externalMetadataColumnId="0" mappedColumnId="0">
    <properties>
        <property id="6877" name="ColumnType"
            dataType="System.Int32" state="default"
            isArray="false" description=
"Specifies whether the column is used to indicate confidence or similarity."
            typeConverter="tcColumnType" UITypeEditor=""
            containsID="false" expressionType="None">2
    </property>
    </properties>
</outputColumn>
<outputColumn id="6972" name=" Similarity_FirstName"
    description="Column-level similarity score for fuzzy join on
column &quot;FirstName&quot;."
    lineageId="6972" precision="0" scale="0"
    length="0" dataType="r4" codePage="0"
    sortKeyPosition="0" comparisonFlags="0"
    specialFlags="0" errorOrTruncationOperation=""
    errorRowDisposition="NotUsed"
    truncationRowDisposition="NotUsed"
    externalMetadataColumnId="0" mappedColumnId="0">
    <properties>
        <property id="6973" name="CopyFromReferenceColumn"
            dataType="System.Null" state="escaped"
            isArray="false" description=
"Specifies the reference table column that is copied to the output for each match result."

```

```

        typeConverter="" UITypeEditor=""
        containsID="false" expressionType="None"/>
    <property id="6974" name="SourceInputColumnLineageID"
        dataType="System.Int32" state="default"
        isArray="false" description=
"Specifies the lineage identifier of the input column from which to copy to this output
column for each match."
        typeConverter="" UITypeEditor=""
        containsID="true" expressionType="None">
3745</property>
    <property id="6975" name="ColumnType"
        dataType="System.Int32" state="default"
        isArray="false" description=
"Specifies whether the column is used to indicate confidence or similarity."
        typeConverter="tcColumnType" UITypeEditor=""
        containsID="false" expressionType="None">3
    </property>
</properties>
</outputColumn>
<outputColumn id="6976" name=" Similarity_LastName"
description="Column-level similarity score for fuzzy join on column &quot;LastName&quot;."
        lineageId="6976" precision="0" scale="0"
        length="0" dataType="r4" codePage="0"
        sortKeyPosition="0" comparisonFlags="0"
        specialFlags="0" errorOrTruncationOperation=""
        errorRowDisposition="NotUsed"
        truncationRowDisposition="NotUsed"
        externalMetadataColumnId="0" mappedColumnId="0">
<properties>
    <property id="6977" name="CopyFromReferenceColumn"
        dataType="System.Null" state="escaped"
        isArray="false" description=
"Specifies the reference table column that is copied to the output for each match result."
        typeConverter="" UITypeEditor=""
        containsID="false" expressionType="None"/>
    <property id="6978" name="SourceInputColumnLineageID"
        dataType="System.Int32" state="default"
        isArray="false" description=
"Specifies the lineage identifier of the input column from which to copy to this output
column for each match."
        typeConverter="" UITypeEditor=""
        containsID="true"
        expressionType="None">3748</property>
    <property id="6979" name="ColumnType"
        dataType="System.Int32" state="default"
        isArray="false" description=
"Specifies whether the column is used to indicate confidence or similarity."
        typeConverter="tcColumnType" UITypeEditor=""
        containsID="false" expressionType="None">3
    </property>
</properties>
</outputColumn>
</outputColumns>
<externalMetadataColumns isUsed="False"/>
</output>
</outputs>
</component>
</components>
<paths>
    <path id="6832" name="Flat File Source Output"
        description="" startId="3729" endId="6818"/>
    <path id="6984" name="Lookup Output" description=""
        startId="6819" endId="6981"/>
    <path id="6985" name="Lookup Error Output" description=""
        startId="6829" endId="6859"/>
    <path id="7045" name="Fuzzy Lookup Output" description=""
        startId="6860" endId="7043"/>
</paths>
</pipeline>

```

```

</DTS:ObjectData>
</DTS:Executable>
<DTS:PackageVariable>
  <DTS:Property DTS:Name="PackageVariableValue" DTS:DataType="8">
    <TaskHost xmlns:xsd="http://www.w3.org/2001/XMLSchema"
xmlns:xsi="http://www.w3.org/2001/XMLSchema-instance"
xmlns:ddl2="http://schemas.microsoft.com/analysisisservices/2003/engine/2"
xmlns:ddl2_2="http://schemas.microsoft.com/analysisisservices/2003/engine/2/2"
xmlns:ddl100_100="http://schemas.microsoft.com/analysisisservices/2008/engine/100/100"
xmlns:dwd="http://schemas.microsoft.com/DataWarehouse/Designer/1.0">< <dwd:DtsDataFlowDiagram>< <dwd:BoundingLeft><-2699</dwd:BoundingLeft>< <dwd:Layout>< <dds><
  <diagram fontclsid="{0BE35203-8F91-11CE-9DE3-00AA004BB851}"
mouseiconclsid="{0BE35204-8F91-11CE-9DE3-00AA004BB851}"
defaultlayout="Microsoft.DataWarehouse.Layout.GraphLayout100"
defaultlineroute="Microsoft.DataWarehouse.Layout.GraphLayout100" version="7" nextobject="31"
scale="100" pagebreakanchorx="0" pagebreakanchory="0" pagebreaksizex="0" pagebreaksizey="0"
scrollleft="0" scrolltop="0" gridx="150" gridy="150" marginx="1000" marginy="1000" zoom="100"
x="18150" y="7620" backcolor="15334399" defaultpersistence="2" PrintPageNumbersMode="3"
PrintMarginTop="0" PrintMarginBottom="635" PrintMarginLeft="0" PrintMarginRight="0"
marqueeselectionmode="1" mousepointer="0" snaptogrid="0" autotypeannotation="1"
showscrollbars="1" viewpagebreaks="0" donotforceconnectorsbehindshapes="0"
backpictureclsid="{00000000-0000-0000-0000-000000000000}"><
  <font><
  <ddsxmlobjectstreamwrapper binary="010000009001c0d40100065461686f6d61" /><
  </font><
  <mouseicon><
  <ddsxmlobjectstreamwrapper binary="6c74000000000000" /><
  </mouseicon><
  </diagram><
  <layoutmanager><
  <ddsxmlobj /><
  </layoutmanager><
  <ddscontrol controlprogid="DdsShapes.DdsObjectManagedBridge.2" tooltip="Flat File
Source" left="-2201" top="0" logicalid="13" controlid="1" masterid="0" hint1="0" hint2="0"
width="5662" height="1164" noresize="0" nomove="0" nodefaultattachpoints="0" autodrag="1"
usedefaultiddshape="1" selectable="1" showselectionhandles="1" allownudging="1"
isannotation="0" dontautolayout="0" groupcollapsed="0" tabstop="1" visible="1"
snaptogrid="0"><
  <control><
  <ddsxmlobjectstreaminitwrapper binary="000800001e1600008c040000" /><
  </control><
  <layoutobject><
  <ddsxmlobj><
  <property name="LogicalObject" value="{7FAA584E-2F45-4786-8410-
8E97F54B0E8D}/components/3728" vartype="8" /><
  <property name="ShowConnectorSource" value="0" vartype="2" /><
  </ddsxmlobj><
  </layoutobject><
  <shape groupshapeid="0" groupnode="0" /><
  </ddscontrol><
  <ddscontrol controlprogid="DdsShapes.DdsObjectManagedBridge.2" tooltip="Looks up
values in a reference dataset by using exact matching." left="-1195" top="2863"
logicalid="14" controlid="2" masterid="0" hint1="0" hint2="0" width="3598" height="1164"
noresize="0" nomove="0" nodefaultattachpoints="0" autodrag="1" usedefaultiddshape="1"
selectable="1" showselectionhandles="1" allownudging="1" isannotation="0" dontautolayout="0"
groupcollapsed="0" tabstop="1" visible="1" snaptogrid="0"><
  <control><
  <ddsxmlobjectstreaminitwrapper binary="000800000e0e00008c040000" /><
  </control><
  <layoutobject><
  <ddsxmlobj><
  <property name="LogicalObject" value="{7FAA584E-2F45-4786-8410-
8E97F54B0E8D}/components/6817" vartype="8" /><
  <property name="ShowConnectorSource" value="0" vartype="2" /><
  </ddsxmlobj><
  </layoutobject><
  <shape groupshapeid="0" groupnode="0" /><
  </ddscontrol><

```

```

    <ddscontrol controlprogid="MSDDS.Polyline" left="205" top="765" logicalid="15"
controlid="3" masterid="0" hint1="0" hint2="0" width="825" height="2598" noresize="0"
nomove="0" nodefaultattachpoints="1" autodrag="0" usedefaultiddshape="0" selectable="1"
showselectionhandles="0" allownudging="1" isannotation="0" dontautolayout="0"
groupcollapsed="0" tabstop="1" visible="1" snaptogrid="0">
    <control>
    <ddsxmlobj>
    <polyline endtypedst="3" endtypesrc="1" usercolor="32768" linestyle="0"
linerender="1" customendtypedstid="0" customendtypesrcid="0" adornsvisible="1" />
    </ddsxmlobj>
    </control>
    </layoutobject>
    <ddsxmlobj>
    <property name="LogicalObject" value="{7FAA584E-2F45-4786-8410-
8E97F54B0E8D}/paths/6832" vartype="8" />
    <property name="Virtual" value="0" vartype="11" />
    <property name="VisibleAP" value="0" vartype="3" />
    </ddsxmlobj>
    </layoutobject>
    <connector lineroutestyle="Microsoft.DataWarehouse.Layout.GraphLayout100"
sourceid="1" destid="2" sourceattachpoint="9" destattachpoint="6" segmentededitmode="0"
bendpointeditmode="0" endpointvisibility="2" relatedid="0" virtual="0">
    <point x="630" y="1164" />
    <point x="630" y="2013" />
    <point x="604" y="2013" />
    <point x="604" y="2863" />
    </connector>
    </ddscontrol>
    <ddscontrol controlprogid="DdsShapes.DdsObjectManagedBridge.2" tooltip="Looks up
values in a reference dataset by using fuzzy matching," left="6504" top="3339" logicalid="16"
controlid="4" masterid="0" hint1="0" hint2="0" width="3598" height="1164" noresize="0"
nomove="0" nodefaultattachpoints="0" autodrag="1" usedefaultiddshape="1" selectable="1"
showselectionhandles="1" allownudging="1" isannotation="0" dontautolayout="0"
groupcollapsed="0" tabstop="1" visible="1" snaptogrid="0">
    <control>
    <ddsxmlobjectstreaminitwrapper binary="000800000e0e00008c040000" />
    </control>
    </layoutobject>
    <ddsxmlobj>
    <property name="LogicalObject" value="{7FAA584E-2F45-4786-8410-
8E97F54B0E8D}/components/6858" vartype="8" />
    <property name="ShowConnectorSource" value="0" vartype="2" />
    </ddsxmlobj>
    </layoutobject>
    <shape groupshapeid="0" groupnode="0" />
    </ddscontrol>
    <ddscontrol controlprogid="DdsShapes.DdsObjectManagedBridge.2" tooltip="Creates
copies of a dataset." left="-1353" top="5958" logicalid="17" controlid="5" masterid="0"
hint1="0" hint2="0" width="3598" height="1164" noresize="0" nomove="0"
nodefaultattachpoints="0" autodrag="1" usedefaultiddshape="1" selectable="1"
showselectionhandles="1" allownudging="1" isannotation="0" dontautolayout="0"
groupcollapsed="0" tabstop="1" visible="1" snaptogrid="0">
    <control>
    <ddsxmlobjectstreaminitwrapper binary="000800000e0e00008c040000" />
    </control>
    </layoutobject>
    <ddsxmlobj>
    <property name="LogicalObject" value="{7FAA584E-2F45-4786-8410-
8E97F54B0E8D}/components/6980" vartype="8" />
    <property name="ShowConnectorSource" value="0" vartype="2" />
    </ddsxmlobj>
    </layoutobject>
    <shape groupshapeid="0" groupnode="0" />
    </ddscontrol>
    <ddscontrol controlprogid="MSDDS.Polyline" left="-345" top="3628" logicalid="18"
controlid="6" masterid="0" hint1="0" hint2="0" width="1191" height="2830" noresize="0"
nomove="0" nodefaultattachpoints="1" autodrag="0" usedefaultiddshape="0" selectable="1"
showselectionhandles="0" allownudging="1" isannotation="0" dontautolayout="0"
groupcollapsed="0" tabstop="1" visible="1" snaptogrid="0">

```



```

    <ddsxmlobj>
    <property name="LogicalObject" value="{7FAA584E-2F45-4786-8410-
8E97F54B0E8D}/components/7042" vartype="8" />
    <property name="ShowConnectorSource" value="0" vartype="2" />
    </ddsxmlobj>
    </layoutobject>
    <shape groupshapeid="0" groupnode="0" />
    </ddscontrol>
    <ddscontrol controlprogid="MSDDS.Polyline" left="8063" top="4104" logicalid="21"
controlid="9" masterid="0" hint1="0" hint2="0" width="1190" height="2672" noresize="0"
nomove="0" nodefaultattachpoints="1" autodrag="0" usedefaultiddshape="0" selectable="1"
showselectionhandles="0" allownudging="1" isannotation="0" dontautolayout="0"
groupcollapsed="0" tabstop="1" visible="1" snaptogrid="0">
    <control>
    <ddsxmlobj>
    <polyline endtypedst="3" endtypesrc="1" usercolor="32768" linestyle="0"
linerender="1" customendtypedstid="0" customendtypesrcid="0" adornsvisible="1">
    <adornment percentpos="50" controlid="14" width="423" height="423" side="1"
behavior="2" himetric="1082" distfromline="175" startobj="0" x="9028" y="5727" visible="1"
allowoverlap="1" usepercent="1" />
    </polyline>
    </ddsxmlobj>
    </control>
    </layoutobject>
    <ddsxmlobj>
    <property name="LogicalObject" value="{7FAA584E-2F45-4786-8410-
8E97F54B0E8D}/paths/7045" vartype="8" />
    <property name="Virtual" value="0" vartype="11" />
    <property name="VisibleAP" value="0" vartype="3" />
    </ddsxmlobj>
    </layoutobject>
    <connector lineroutestyle="Microsoft.DataWarehouse.Layout.GraphLayout100"
sourceid="4" destid="8" sourceattachpoint="9" destattachpoint="6" segmenteditmode="0"
bendpointeditmode="0" bendpointvisibility="2" relatedid="0" virtual="0">
    <point x="8853" y="4503" />
    <point x="8853" y="5832" />
    <point x="8462" y="5832" />
    <point x="8462" y="6276" />
    </connector>
    </ddscontrol>
    <ddscontrol controlprogid="MSDDS.Text" left="-2699" top="5614" logicalid="25"
controlid="13" masterid="6" hint1="0" hint2="0" width="2970" height="344" noresize="1"
nomove="0" nodefaultattachpoints="1" autodrag="1" usedefaultiddshape="1" selectable="0"
showselectionhandles="0" allownudging="1" isannotation="0" dontautolayout="1"
groupcollapsed="0" tabstop="0" visible="1" snaptogrid="0">
    <control>
    <ddsxmlobjectstreaminitwrapper
binary="000200009a0b000058010000030000000000500008008000080010000003500010000009001444201000
65461686f6d6113004c006f006f006b007500700020004d00610074006300680020004f0075007400700075007400
00000000" />
    </control>
    </layoutobject>
    <ddsxmlobj>
    <property name="AnnotationAdornment" value="-1" vartype="11" />
    </ddsxmlobj>
    </layoutobject>
    <shape groupshapeid="0" groupnode="0" />
    </ddscontrol>
    <ddscontrol controlprogid="DdsShapes.DdsObjectManagedBridge.2" left="9028"
top="5727" logicalid="26" controlid="14" masterid="9" hint1="0" hint2="0" width="423"
height="423" noresize="1" nomove="1" nodefaultattachpoints="1" autodrag="0"
usedefaultiddshape="1" selectable="0" showselectionhandles="1" allownudging="1"
isannotation="0" dontautolayout="1" groupcollapsed="0" tabstop="0" visible="1"
snaptogrid="0">
    <control>
    <ddsxmlobjectstreaminitwrapper binary="00080000a7010000a7010000" />
    </control>
    </layoutobject>
    <ddsxmlobj>

```

```

<property name="VisualizerAdornment" value="-1" vartype="11" />
</ddsxmlobj>
</layoutobject>
<shape groupshapeid="0" groupnode="0" />
</ddscontrol>
<ddscontrol controlprogid="MSDDS.Text" left="2721" top="4096" logicalid="27"
controlid="15" masterid="7" hint1="0" hint2="0" width="2826" height="344" noresize="1"
nomove="0" nodefaultattachpoints="1" autodrag="1" usedefaultiddshape="1" selectable="0"
showselectionhandles="0" allownudging="1" isannotation="0" dontautolayout="1"
groupcollapsed="0" tabstop="0" visible="1" snaptogrid="0">
<control>
<ddsxmlobjectstreaminitwrapper
binary="000200000a0b000058010000300000000000500008008000080010000003500010000009001444201000
65461686f6d6113004c006f006f006b007500700020004500720072006f00720020004f0075007400700075007400
00000000" />
</control>
</layoutobject>
<property name="AnnotationAdornment" value="-1" vartype="11" />
</ddsxmlobj>
</layoutobject>
<shape groupshapeid="0" groupnode="0" />
</ddscontrol>

</dds>
</dwd:Layout>
</dwd:DtsDataFlowDiagram>
</dwd:DtsComponentDesignerPro
pertiesList>
</dwd:DtsComponentDesignTimeProperty>
</dwd:key
xsi:type="xsd:string">3751DataSourceViewID</dwd:key>
</dwd:DtsComponentDesignTimeP
roperty>
</dwd:DtsComponentDesignTimeProperty>
</dwd:key
xsi:type="xsd:string">427TableInfoObjectType</dwd:key>
</dwd:value
xsi:type="xsd:string">Table</dwd:value>
</dwd:DtsComponentDesignTimeProperty>
</dwd:DtsComponentDesignTimeProperty>
</dwd:key
xsi:type="xsd:string">3881DataSourceViewID</dwd:key>
</dwd:DtsComponentDesignTimeP
roperty>
</dwd:DtsComponentDesignTimeProperty>
</dwd:key
xsi:type="xsd:string">6817OverwriteParamsSQLProp</dwd:key>
</dwd:value
xsi:type="xsd:boolean">>false</dwd:value>
</dwd:DtsComponentDesignTimeProperty>
</dwd:DtsComponentDesignTimeProperty>
</dwd:key
xsi:type="xsd:string">536TableInfoObjectType</dwd:key>
</dwd:value
xsi:type="xsd:string">Table</dwd:value>
</dwd:DtsComponentDesignTimeProperty>
</dwd:DtsComponentDesignTimeProperty>
</dwd:key
xsi:type="xsd:string">3537DataSourceViewID</dwd:key>
</dwd:DtsComponentDesignTimeP
roperty>
</dwd:DtsComponentDesignTimeProperty>
</dwd:key
xsi:type="xsd:string">1TableInfoObjectType</dwd:key>
</dwd:value
xsi:type="xsd:string">Table</dwd:value>
</dwd:DtsComponentDesignTimeProperty>
</dwd:DtsComponentDesignTimeProperty>
</dwd:key
xsi:type="xsd:string">536OverwriteParamsSQLProp</dwd:key>
</dwd:value
xsi:type="xsd:boolean">>false</dwd:value>
</dwd:DtsComponentDesignTimeProperty>
</dwd:DtsComponentDesignTimeProperty>
</dwd:key
xsi:type="xsd:string">3751TableInfoObjectType</dwd:key>
</dwd:value
xsi:type="xsd:string">Table</dwd:value>
</dwd:DtsComponentDesignTimeProperty>
</dwd:DtsComponentDesignTimeProperty>
</dwd:key
xsi:type="xsd:string">536DataSourceViewID</dwd:key>
</dwd:DtsComponentDesignTimePr
operty>
</dwd:DtsComponentDesignTimeProperty>
</dwd:key
xsi:type="xsd:string">6817DataSourceViewID</dwd:key>
</dwd:DtsComponentDesignTimeP
roperty>
</dwd:DtsComponentDesignTimeProperty>
</dwd:key
xsi:type="xsd:string">3537TableInfoObjectType</dwd:key>
</dwd:value
xsi:type="xsd:string">Table</dwd:value>
</dwd:DtsComponentDesignTimeProperty>
</dwd:DtsComponentDesignTimeProperty>
</dwd:key
xsi:type="xsd:string">1DataSourceViewID</dwd:key>
</dwd:DtsComponentDesignTimeProp
erty>
</dwd:DtsComponentDesignTimeProperty>
</dwd:key
xsi:type="xsd:string">6858TableInfoObjectType</dwd:key>
</dwd:value
xsi:type="xsd:string">Table</dwd:value>
</dwd:DtsComponentDesignTimeProperty>
</dwd:DtsComponentDesignTimeProperty>
</dwd:key
xsi:type="xsd:string">3881TableInfoObjectType</dwd:key>
</dwd:value
xsi:type="xsd:string">Table</dwd:value>
</dwd:DtsComponentDesignTimeProperty>
</dwd:DtsComponentDesignTimeProperty>
</dwd:key
xsi:type="xsd:string">6817TableInfoObjectType</dwd:key>
</dwd:value
xsi:type="xsd:int">0</dwd:value>
</dwd:DtsComponentDesignTimeProperty>
</dwd:DtsComponentDesignTimeProperty>
</dwd:key
xsi:type="xsd:string">3751OverwriteParamsSQLProp</dwd:key>
</dwd:value

```



```

xsi:type="xsd:boolean">false</dwd:value></dwd:DtsComponentDesignTimeProperty>&
lt;dwd:DtsComponentDesignTimeProperty></dwd:key
xsi:type="xsd:string">3751UsedTableName</dwd:key></dwd:value
xsi:type="xsd:string">[Person].[Contact]</dwd:value></dwd:DtsComponentDesignTimeP
roperty></dwd:DtsComponentDesignTimeProperty></dwd:key
xsi:type="xsd:string">427DataSourceViewID</dwd:key></dwd:DtsComponentDesignTimePr
operty></dwd:DtsComponentDesignTimeProperty></dwd:key
xsi:type="xsd:string">6858DataSourceViewID</dwd:key></dwd:DtsComponentDesignTimeP
roperty></dwd:DtsComponentDesignTimeProperty></dwd:key
xsi:type="xsd:string">536UsedTableName</dwd:key></dwd:value
xsi:type="xsd:string">[Person].[Contact]</dwd:value></dwd:DtsComponentDesignTimeP
roperty></dwd:DtsComponentDesignTimeProperty></dwd:key
xsi:type="xsd:string">6817UsedTableName</dwd:key></dwd:value
xsi:type="xsd:string">[Person].[Contact]</dwd:value></dwd:DtsComponentDesignTimeP
roperty></dwd:DtsComponentDesignerPropertiesList></TaskHost>
</DTS:Property>
<DTS:Property DTS:Name="Namespace">dts-designer-1.0</DTS:Property>
<DTS:Property DTS:Name="ObjectName">
  {7FAA584E-2F45-4786-8410-8E97F54B0E8D}</DTS:Property>
<DTS:Property DTS:Name="DTSID">{5BBFB200-DBD1-428A-BD70-2F2B4FA6848E}</DTS:Property>
<DTS:Property DTS:Name="Description"></DTS:Property>
<DTS:Property DTS:Name="CreationName"></DTS:Property>
</DTS:PackageVariable>
<DTS:PackageVariable>
  <DTS:Property DTS:Name="PackageVariableValue" DTS:DataType="8">
    &lt;PipelinePath xmlns:xsd="http://www.w3.org/2001/XMLSchema"
xmlns:xsi="http://www.w3.org/2001/XMLSchema-instance"
xmlns:ddl2="http://schemas.microsoft.com/analysisisservices/2003/engine/2"
xmlns:ddl2_2="http://schemas.microsoft.com/analysisisservices/2003/engine/2/2"
xmlns:ddl100_100="http://schemas.microsoft.com/analysisisservices/2008/engine/100/100"
xmlns:dwd="http://schemas.microsoft.com/DataWarehouse/Designer/1.0">&lt;dwd:SourceName>&lt;
Flat File Source Output</dwd:SourceName>&lt;dwd:DestinationName>&lt;Lookup
Input</dwd:DestinationName>&lt;/PipelinePath>
  </DTS:Property>
  <DTS:Property DTS:Name="Namespace">dts-designer-1.0</DTS:Property>
  <DTS:Property DTS:Name="ObjectName">
    {7FAA584E-2F45-4786-8410-8E97F54B0E8D}-6832</DTS:Property>
  <DTS:Property DTS:Name="DTSID">
    {2A5D370B-C48E-4515-A29F-72C075ED27DC}</DTS:Property>
  <DTS:Property DTS:Name="Description"></DTS:Property>
  <DTS:Property DTS:Name="CreationName"></DTS:Property>
  </DTS:PackageVariable>
  <DTS:PackageVariable>
    <DTS:Property DTS:Name="PackageVariableValue" DTS:DataType="8">
      &lt;PipelinePath xmlns:xsd="http://www.w3.org/2001/XMLSchema"
xmlns:xsi="http://www.w3.org/2001/XMLSchema-instance"
xmlns:ddl2="http://schemas.microsoft.com/analysisisservices/2003/engine/2"
xmlns:ddl2_2="http://schemas.microsoft.com/analysisisservices/2003/engine/2/2"
xmlns:ddl100_100="http://schemas.microsoft.com/analysisisservices/2008/engine/100/100"
xmlns:dwd="http://schemas.microsoft.com/DataWarehouse/Designer/1.0">&lt;dwd:SourceName>&lt;
Lookup Match Output</dwd:SourceName>&lt;dwd:DestinationName>&lt;Multicast Input
1</dwd:DestinationName>&lt;/PipelinePath>
    </DTS:Property>
    <DTS:Property DTS:Name="Namespace">dts-designer-1.0</DTS:Property>
    <DTS:Property DTS:Name="ObjectName">
      {7FAA584E-2F45-4786-8410-8E97F54B0E8D}-6984</DTS:Property>
    <DTS:Property DTS:Name="DTSID">
      {EA6738C2-7F1C-4779-A540-4B85CD7B377F}</DTS:Property>
    <DTS:Property DTS:Name="Description"></DTS:Property>
    <DTS:Property DTS:Name="CreationName"></DTS:Property>
  </DTS:PackageVariable>
  <DTS:PackageVariable>
    <DTS:Property DTS:Name="PackageVariableValue" DTS:DataType="8">
      &lt;PipelinePath xmlns:xsd="http://www.w3.org/2001/XMLSchema"
xmlns:xsi="http://www.w3.org/2001/XMLSchema-instance"
xmlns:ddl2="http://schemas.microsoft.com/analysisisservices/2003/engine/2"
xmlns:ddl2_2="http://schemas.microsoft.com/analysisisservices/2003/engine/2/2"
xmlns:ddl100_100="http://schemas.microsoft.com/analysisisservices/2008/engine/100/100"

```

```

xmlns:dwd="http://schemas.microsoft.com/DataWarehouse/Designer/1.0"><<dwd:PathAnnotation
&gt;<PathName&lt;/dwd:PathAnnotation&gt;<<dwd:SourceName&gt;<Lookup Error
Output&lt;/dwd:SourceName&gt;<<dwd:DestinationName&gt;<Fuzzy Lookup
Input&lt;/dwd:DestinationName&gt;<</PipelinePath&gt;
</DTS:Property>
<DTS:Property DTS:Name="Namespace">dts-designer-1.0</DTS:Property>
<DTS:Property DTS:Name="ObjectName">
  {7FAA584E-2F45-4786-8410-8E97F54B0E8D}-6985</DTS:Property>
<DTS:Property DTS:Name="DTSID">
  {ACF27AB3-F2DE-4E03-87F8-6CB55E807799}</DTS:Property>
<DTS:Property DTS:Name="Description"><</DTS:Property>
<DTS:Property DTS:Name="CreationName"><</DTS:Property>
</DTS:PackageVariable>
<DTS:PackageVariable>
  <DTS:Property DTS:Name="PackageVariableValue" DTS:DataType="8">
    &lt;PipelinePath xmlns:xsd="http://www.w3.org/2001/XMLSchema"
    xmlns:xsi="http://www.w3.org/2001/XMLSchema-instance"
    xmlns:ddl2="http://schemas.microsoft.com/analysisisservices/2003/engine/2"
    xmlns:ddl2_2="http://schemas.microsoft.com/analysisisservices/2003/engine/2/2"
    xmlns:ddl100_100="http://schemas.microsoft.com/analysisisservices/2008/engine/100/100"
xmlns:dwd="http://schemas.microsoft.com/DataWarehouse/Designer/1.0"><<dwd:SourceName&gt;
Fuzzy Lookup Output&lt;/dwd:SourceName&gt;<<dwd:DestinationName&gt;<Multicast Input
1&lt;/dwd:DestinationName&gt;<</PipelinePath&gt;
</DTS:Property>
<DTS:Property DTS:Name="Namespace">dts-designer-1.0</DTS:Property>
<DTS:Property DTS:Name="ObjectName">
  {7FAA584E-2F45-4786-8410-8E97F54B0E8D}-7045</DTS:Property>
<DTS:Property DTS:Name="DTSID">
  {C6C34E41-0F6A-4D48-8321-89822D3673F7}</DTS:Property>
<DTS:Property DTS:Name="Description"><</DTS:Property>
<DTS:Property DTS:Name="CreationName"><</DTS:Property>
</DTS:PackageVariable>
<DTS:PackageVariable>
  <DTS:Property DTS:Name="PackageVariableValue" DTS:DataType="8">
    &lt;Package xmlns:xsd="http://www.w3.org/2001/XMLSchema"
    xmlns:xsi="http://www.w3.org/2001/XMLSchema-instance"
    xmlns:ddl2="http://schemas.microsoft.com/analysisisservices/2003/engine/2"
    xmlns:ddl2_2="http://schemas.microsoft.com/analysisisservices/2003/engine/2/2"
    xmlns:ddl100_100="http://schemas.microsoft.com/analysisisservices/2008/engine/100/100"
xmlns:dwd="http://schemas.microsoft.com/DataWarehouse/Designer/1.0"><<dwd:DtsControlFlow
Diagram&gt;<<dwd:Layout&gt;<<dds&gt;
  &lt;diagram fontclsid="{0BE35203-8F91-11CE-9DE3-00AA004BB851}"
  mouseiconclsid="{0BE35204-8F91-11CE-9DE3-00AA004BB851}"
  defaultlayout="Microsoft.DataWarehouse.Layout.GraphLayout100"
  defaultlineroute="Microsoft.DataWarehouse.Layout.GraphLayout100"
  version="7" nextobject="5" scale="100" pagebreakanchorx="0"
  pagebreakanchory="0" pagebreaksizex="0" pagebreaksizey="0"
  scrollleft="0" scrolltop="0" gridx="150" gridy="150" marginx="1000"
  marginy="1000" zoom="100" x="18150" y="9022" backcolor="15334399" d
  efaultpersistence="2" PrintPageNumbersMode="3" PrintMarginTop="0"
  PrintMarginBottom="635" PrintMarginLeft="0" PrintMarginRight="0"
  marqueeselectionmode="1" mousepointer="0" snaptogrid="0"
  autotypeannotation="1" showscrollbars="0" viewpagebreaks="0"
  donotforceconnectorsbehindshapes="1"
  backpictureclsid="{00000000-0000-0000-0000-000000000000}"&gt;
  &lt;font&gt;
  &lt;ddsxmlobjectstreamwrapper binary="010000009001c0d40100065461686f6d61" /&gt;
  &lt;/font&gt;
  &lt;mouseicon&gt;
  &lt;ddsxmlobjectstreamwrapper binary="6c74000000000000" /&gt;
  &lt;/mouseicon&gt;
  &lt;/diagram&gt;
  &lt;layoutmanager&gt;
  &lt;ddsxmlobj /&gt;
  &lt;/layoutmanager&gt;

```

```

        <lt;ddscontrol controlprogid="DdsShapes.DdsObjectManagedBridge.2" tooltip="Data Flow
Task" left="5622" top="5146" logicalid="2" controlid="1" masterid="0" hint1="0" hint2="0"
width="4392" height="1164" noresize="0" nomove="0" nodefaultattachpoints="0" autodrag="1"
usedefaultiddshape="1" selectable="1" showselectionhandles="1" allownudging="1"
isannotation="0" dontautolayout="0" groupcollapsed="0" tabstop="1" visible="1"
snaptogrid="0">
        <lt;control>
        <lt;ddsxmlobjectstreaminitwrapper binary="00080000281100008c040000" />
        <lt;/control>
        <lt;layoutobject>
        <lt;ddsxmlobj>
        <lt;property name="LogicalObject" value="{7FAA584E-2F45-4786-8410-8E97F54B0E8D}"
vartype="8" />
        <lt;property name="ShowConnectorSource" value="0" vartype="2" />
        <lt;/ddsxmlobj>
        <lt;/layoutobject>
        <lt;shape groupshapeid="0" groupnode="0" />
        <lt;/ddscontrol>
        <lt;/dds>><lt;/dwd:Layout>><lt;/dwd:DtsControlFlowDiagram>><lt;/Package>>
</DTS:Property>
<DTS:Property DTS:Name="Namespace">dts-designer-1.0</DTS:Property>
<DTS:Property DTS:Name="ObjectName">
{ECF155AC-F433-4930-A0A1-BE9B065E004D}</DTS:Property>
<DTS:Property DTS:Name="DTSID">
{659D145B-8BBE-4273-B57A-B579BF934B7E}</DTS:Property>
<DTS:Property DTS:Name="Description"></DTS:Property>
<DTS:Property DTS:Name="CreationName"></DTS:Property>
</DTS:PackageVariable>
<DTS:PackageVariable>
<DTS:Property DTS:Name="PackageVariableValue" DTS:DataType="8">
<lt;Package xmlns:xsd="http://www.w3.org/2001/XMLSchema"
xmlns:xsi="http://www.w3.org/2001/XMLSchema-instance"
xmlns:ddl2="http://schemas.microsoft.com/analysisservices/2003/engine/2"
xmlns:ddl2_2="http://schemas.microsoft.com/analysisservices/2003/engine/2/2"
xmlns:ddl100_100="http://schemas.microsoft.com/analysisservices/2008/engine/100/100"

xmlns:dwd="http://schemas.microsoft.com/DataWarehouse/Designer/1.0">><lt;/dwd:DtsControlFlow
Diagram>><lt;/dwd:Layout>><lt;/dds>>
        <lt;diagram fontclsid="{0BE35203-8F91-11CE-9DE3-00AA004BB851}"
mouseiconclsid="{0BE35204-8F91-11CE-9DE3-00AA004BB851}"
defaultlayout="Microsoft.DataWarehouse.Layout.GraphLayout100"
defaultlineroute="Microsoft.DataWarehouse.Layout.GraphLayout100" version="7" nextobject="5"
scale="100" pagebreakanchorx="0" pagebreakanchory="0" pagebreaksize="0" pagebreaksizey="0"
scrollleft="0" scrolltop="0" gridx="150" gridy="150" marginx="1000" marginy="1000" zoom="100"
x="18150" y="9022" bgcolor="15334399" defaultpersistence="2" PrintPageNumbersMode="3"
PrintMarginTop="0" PrintMarginBottom="635" PrintMarginLeft="0" PrintMarginRight="0"
marqueeselectionmode="1" mousepointer="0" snaptogrid="0" autotypeannotation="1"
showscrollbars="0" viewpagebreaks="0" donotforceconnectorsbehindshapes="1"
backpictureclsid="{00000000-0000-0000-0000-000000000000}">>
        <lt;font>
        <lt;ddsxmlobjectstreamwrapper binary="010000009001c0d40100065461686f6d61" />
        <lt;/font>
        <lt;mouseicon>
        <lt;ddsxmlobjectstreamwrapper binary="6c74000000000000" />
        <lt;/mouseicon>
        <lt;/diagram>
        <lt;layoutmanager>
        <lt;ddsxmlobj />
        <lt;/layoutmanager>
        <lt;ddscontrol controlprogid="DdsShapes.DdsObjectManagedBridge.2" tooltip="Data Flow
Task" left="5622" top="5146" logicalid="2" controlid="1" masterid="0" hint1="0" hint2="0"
width="4392" height="1164" noresize="0" nomove="0" nodefaultattachpoints="0" autodrag="1"
usedefaultiddshape="1" selectable="1" showselectionhandles="1" allownudging="1"
isannotation="0" dontautolayout="0" groupcollapsed="0" tabstop="1" visible="1"
snaptogrid="0">
        <lt;control>
        <lt;ddsxmlobjectstreaminitwrapper binary="00080000281100008c040000" />
        <lt;/control>
        <lt;layoutobject>

```



```

<DTS:Property DTS:Name="PackageType">5</DTS:Property>
<DTS:Property DTS:Name="ProtectionLevel">0</DTS:Property>
<DTS:Property DTS:Name="MaxConcurrentExecutables">-1</DTS:Property>
<DTS:Property DTS:Name="PackagePriorityClass">0</DTS:Property>
<DTS:Property DTS:Name="VersionMajor">1</DTS:Property>
<DTS:Property DTS:Name="VersionMinor">0</DTS:Property>
<DTS:Property DTS:Name="VersionBuild">117</DTS:Property>
<DTS:Property DTS:Name="VersionGUID">
  {40ABC5F1-B82B-495A-906D-722AD510135F}</DTS:Property>
<DTS:Property DTS:Name="EnableConfig">-1</DTS:Property>
<DTS:Property DTS:Name="CheckpointFileName"></DTS:Property>
<DTS:Property DTS:Name="SaveCheckpoints">0</DTS:Property>
<DTS:Property DTS:Name="CheckpointUsage">0</DTS:Property>
<DTS:Property DTS:Name="SuppressConfigurationWarnings">0</DTS:Property>
<DTS:Property DTS:Name="LastModifiedProductVersion">10.0.2531.0
</DTS:Property>
<DTS:Property DTS:Name="ForceExecValue">0</DTS:Property>
<DTS:Property DTS:Name="ExecValue" DTS:DataType="3">0</DTS:Property>
<DTS:Property DTS:Name="ForceExecutionResult">-1</DTS:Property>
<DTS:Property DTS:Name="Disabled">0</DTS:Property>
<DTS:Property DTS:Name="FailPackageOnFailure">0</DTS:Property>
<DTS:Property DTS:Name="FailParentOnFailure">0</DTS:Property>
<DTS:Property DTS:Name="MaxErrorCount">1</DTS:Property>
<DTS:Property DTS:Name="ISOLevel">1048576</DTS:Property>
<DTS:Property DTS:Name="LocaleID">1033</DTS:Property>
<DTS:Property DTS:Name="TransactionOption">1</DTS:Property>
<DTS:Property DTS:Name="DelayValidation">0</DTS:Property>
<DTS:Property DTS:Name="ObjectName">WebService</DTS:Property>
<DTS:Property DTS:Name="DTSID">{6BC04190-25CC-422A-92BE-68ACBD6F59E8}
</DTS:Property>
<DTS:Property DTS:Name="Description"></DTS:Property>
<DTS:Property DTS:Name="CreationName">SSIS.Package.2</DTS:Property>
<DTS:Property DTS:Name="DisableEventHandlers">0</DTS:Property>
<DTS:ConnectionManager>
  <DTS:Property DTS:Name="DelayValidation">0</DTS:Property>
  <DTS:Property DTS:Name="ObjectName">cmService</DTS:Property>
  <DTS:Property DTS:Name="DTSID">{2DA145FD-9C6E-487D-9A50-DD97C1D11763}</DTS:Property>
  <DTS:Property DTS:Name="Description"></DTS:Property>
  <DTS:Property DTS:Name="CreationName">HTTP</DTS:Property>
  <DTS:ObjectData>
    <DTS:ConnectionManager>
      <DTS:Property
DTS:Name="ConnectionString">http://www.ecubicle.net/livestockquotes.asmx?WSDL</DTS:Property>
      <DTS:HttpConnection>
        <DTS:Property
DTS:Name="ServerURL">http://www.ecubicle.net/livestockquotes.asmx?WSDL</DTS:Property>
        <DTS:Property DTS:Name="UseServerCredentials">0</DTS:Property>
        <DTS:Property DTS:Name="ServerUserName"></DTS:Property>
        <DTS:Property DTS:Name="ServerPassword" Sensitive="1"></DTS:Property>
        <DTS:Property DTS:Name="ServerDomain"></DTS:Property>
        <DTS:Property DTS:Name="UseSecureConnection">0</DTS:Property>
        <DTS:Property DTS:Name="CertificateIdentifier"></DTS:Property>
        <DTS:Property DTS:Name="Certificate"></DTS:Property>
        <DTS:Property DTS:Name="TimeOut">30</DTS:Property>
        <DTS:Property DTS:Name="ChunkSize">1</DTS:Property>
        <DTS:Property DTS:Name="UseProxy">0</DTS:Property>
        <DTS:Property DTS:Name="ProxyURL"></DTS:Property>
        <DTS:Property DTS:Name="BypassProxyOnLocal">0</DTS:Property>
        <DTS:Property DTS:Name="UseProxyCredentials">0</DTS:Property>
        <DTS:Property DTS:Name="ProxyUserName"></DTS:Property>
        <DTS:Property DTS:Name="ProxyPassword" Sensitive="1"></DTS:Property>
        <DTS:Property DTS:Name="ProxyDomain"></DTS:Property>
        <DTS:Property DTS:Name="BypassList"></DTS:Property>
      </DTS:HttpConnection>
    </DTS:ConnectionManager>
  </DTS:ObjectData>
</DTS:ConnectionManager>
<DTS:ConnectionManager>
  <DTS:Property DTS:Name="DelayValidation">0</DTS:Property>

```

```

<DTS:Property DTS:Name="ObjectName">foo</DTS:Property>
<DTS:Property DTS:Name="DTSID">{C5C2675C-13D7-4DED-B499-9F45AA97C32A}</DTS:Property>
<DTS:Property DTS:Name="Description"></DTS:Property>
<DTS:Property DTS:Name="CreationName">FILE</DTS:Property>
<DTS:ObjectData>
  <DTS:ConnectionManager>
    <DTS:Property DTS:Name="FileUsageType">1</DTS:Property>
    <DTS:Property DTS:Name="ConnectionString">foo</DTS:Property>
  </DTS:ConnectionManager>
</DTS:ObjectData>
</DTS:ConnectionManager>
<DTS:Configuration>
  <DTS:Property DTS:Name="ConfigurationType">2</DTS:Property>
  <DTS:Property DTS:Name="ConfigurationString">SSISSAMPLESROOT</DTS:Property>
  <DTS:Property
DTS:Name="ConfigurationVariable">\Package.Variables[SAMPLES::ROOTWD].Properties[Value]</DTS:P
roperty>
  <DTS:Property DTS:Name="ObjectName">Configure The Root Folder</DTS:Property>
  <DTS:Property DTS:Name="DTSID">{90405045-3A91-43C2-B759-6C183C0E81A6}</DTS:Property>
  <DTS:Property DTS:Name="Description"></DTS:Property>
  <DTS:Property DTS:Name="CreationName"></DTS:Property>
</DTS:Configuration>
<DTS:Configuration>
  <DTS:Property DTS:Name="ConfigurationType">2</DTS:Property>
  <DTS:Property DTS:Name="ConfigurationString">SSISSAMPLESERVER</DTS:Property>
  <DTS:Property
DTS:Name="ConfigurationVariable">\Package.Variables[SAMPLES::SERVERNAME].Properties[Value]</D
TS:Property>
  <DTS:Property DTS:Name="ObjectName">Configure The Sample Server Name</DTS:Property>
  <DTS:Property DTS:Name="DTSID">{A9F64F24-15C2-4198-A308-F9124C48468D}</DTS:Property>
  <DTS:Property DTS:Name="Description"></DTS:Property>
  <DTS:Property DTS:Name="CreationName"></DTS:Property>
</DTS:Configuration>
<DTS:Variable>
  <DTS:Property DTS:Name="Expression">@ROOTWD + "\\\" + @SAMPLESUBFOLDER</DTS:Property>
  <DTS:Property DTS:Name="EvaluateAsExpression">-1</DTS:Property>
  <DTS:Property DTS:Name="Namespace">SAMPLES</DTS:Property>
  <DTS:Property DTS:Name="ReadOnly">0</DTS:Property>
  <DTS:Property DTS:Name="RaiseChangedEvent">0</DTS:Property>
  <DTS:Property DTS:Name="IncludeInDebugDump">2345</DTS:Property>
  <DTS:Property DTS:Name="ObjectName">CURRENTWD</DTS:Property>
  <DTS:Property DTS:Name="DTSID">{E05C4384-FA46-4EDB-9E41-E0CDD6DD4DC6}</DTS:Property>
  <DTS:Property DTS:Name="Description"></DTS:Property>
  <DTS:Property DTS:Name="CreationName"></DTS:Property>
  <DTS:VariableValue DTS:DataType="8">C:\USERS\username.DOMAIN\MY
DOCUMENTS\SSIS\BOOKSAMPLES2005\S08-StockTasks</DTS:VariableValue>
</DTS:Variable>
<DTS:Variable>
  <DTS:Property DTS:Name="Expression"></DTS:Property>
  <DTS:Property DTS:Name="EvaluateAsExpression">0</DTS:Property>
  <DTS:Property DTS:Name="Namespace">SAMPLES</DTS:Property>
  <DTS:Property DTS:Name="ReadOnly">0</DTS:Property>
  <DTS:Property DTS:Name="RaiseChangedEvent">0</DTS:Property>
  <DTS:Property DTS:Name="IncludeInDebugDump">2345</DTS:Property>
  <DTS:Property DTS:Name="ObjectName">ROOTWD</DTS:Property>
  <DTS:Property DTS:Name="DTSID">{3BD365BA-FE06-4B5A-8100-69F27C71B74E}</DTS:Property>
  <DTS:Property DTS:Name="Description"></DTS:Property>
  <DTS:Property DTS:Name="CreationName"></DTS:Property>
  <DTS:VariableValue DTS:DataType="8">C:\USERS\username.DOMAIN\MY
DOCUMENTS\SSIS\BOOKSAMPLES2005</DTS:VariableValue>
</DTS:Variable>
<DTS:Variable>
  <DTS:Property DTS:Name="Expression"></DTS:Property>
  <DTS:Property DTS:Name="EvaluateAsExpression">0</DTS:Property>
  <DTS:Property DTS:Name="Namespace">SAMPLES</DTS:Property>
  <DTS:Property DTS:Name="ReadOnly">0</DTS:Property>
  <DTS:Property DTS:Name="RaiseChangedEvent">0</DTS:Property>
  <DTS:Property DTS:Name="IncludeInDebugDump">2345</DTS:Property>
  <DTS:Property DTS:Name="ObjectName">SAMPLESUBFOLDER</DTS:Property>

```

```

    <DTS:Property DTS:Name="DTSID">{6E7FB8C5-7F98-454E-87E0-D9BF0D0E06AD}</DTS:Property>
    <DTS:Property DTS:Name="Description"></DTS:Property>
    <DTS:Property DTS:Name="CreationName"></DTS:Property>
    <DTS:VariableValue DTS:DataType="8">S08-StockTasks</DTS:VariableValue>
  </DTS:Variable>
  <DTS:Variable>
    <DTS:Property DTS:Name="Expression"></DTS:Property>
    <DTS:Property DTS:Name="EvaluateAsExpression">0</DTS:Property>
    <DTS:Property DTS:Name="Namespace">SAMPLES</DTS:Property>
    <DTS:Property DTS:Name="ReadOnly">0</DTS:Property>
    <DTS:Property DTS:Name="RaiseChangedEvent">0</DTS:Property>
    <DTS:Property DTS:Name="IncludeInDebugDump">2345</DTS:Property>
    <DTS:Property DTS:Name="ObjectName">SERVERNAME</DTS:Property>
    <DTS:Property DTS:Name="DTSID">{5F9998D0-186D-4C44-A949-66C8477A3CE7}</DTS:Property>
    <DTS:Property DTS:Name="Description"></DTS:Property>
    <DTS:Property DTS:Name="CreationName"></DTS:Property>
    <DTS:VariableValue DTS:DataType="8">.</DTS:VariableValue>
  </DTS:Variable>
  <DTS:Variable>
    <DTS:Property DTS:Name="Expression"></DTS:Property>
    <DTS:Property DTS:Name="EvaluateAsExpression">0</DTS:Property>
    <DTS:Property DTS:Name="Namespace">SAMPLES</DTS:Property>
    <DTS:Property DTS:Name="ReadOnly">0</DTS:Property>
    <DTS:Property DTS:Name="RaiseChangedEvent">0</DTS:Property>
    <DTS:Property DTS:Name="IncludeInDebugDump">2345</DTS:Property>
    <DTS:Property DTS:Name="ObjectName">STOCKQUOTE</DTS:Property>
    <DTS:Property DTS:Name="DTSID">{E084171E-93C0-43BC-BC6C-83833B78109E}</DTS:Property>
    <DTS:Property DTS:Name="Description"></DTS:Property>
    <DTS:Property DTS:Name="CreationName"></DTS:Property>
    <DTS:VariableValue DTS:DataType="8"></DTS:VariableValue>
  </DTS:Variable>
  <DTS:Variable>
    <DTS:Property DTS:Name="Expression"></DTS:Property>
    <DTS:Property DTS:Name="EvaluateAsExpression">0</DTS:Property>
    <DTS:Property DTS:Name="Namespace">SAMPLES</DTS:Property>
    <DTS:Property DTS:Name="ReadOnly">0</DTS:Property>
    <DTS:Property DTS:Name="RaiseChangedEvent">0</DTS:Property>
    <DTS:Property DTS:Name="IncludeInDebugDump">2345</DTS:Property>
    <DTS:Property DTS:Name="ObjectName">TICKERSYMBOL</DTS:Property>
    <DTS:Property DTS:Name="DTSID">{58589E35-3D84-4D07-8A32-A75E6591D7F0}</DTS:Property>
    <DTS:Property DTS:Name="Description"></DTS:Property>
    <DTS:Property DTS:Name="CreationName"></DTS:Property>
    <DTS:VariableValue DTS:DataType="8">MSFT</DTS:VariableValue>
  </DTS:Variable>
  <DTS:LoggingOptions>
    <DTS:Property DTS:Name="LoggingMode">0</DTS:Property>
    <DTS:Property DTS:Name="FilterKind">1</DTS:Property>
    <DTS:Property DTS:Name="EventFilter" DTS:DataType="8"></DTS:Property>
  </DTS:LoggingOptions>
  <DTS:Executable DTS:ExecutableType=
  "Microsoft.SqlServer.Dts.Tasks.WebServiceTask.WebServiceTask,
  Microsoft.SqlServer.WebServiceTask, Version=10.0.0.0, Culture=neutral,
  PublicKeyToken=89845dcd8080cc91"
    DTS:ThreadHint="0">
    <DTS:Property DTS:Name="ExecutionLocation">0</DTS:Property>
    <DTS:Property DTS:Name="ExecutionAddress"></DTS:Property>
    <DTS:Property DTS:Name="TaskContact">
  Web Service Task; Microsoft Corporation; Microsoft SQL Server v9; © 2004 Microsoft
  Corporation; All Rights Reserved;http://www.microsoft.com/sql/support/default.asp;1
  </DTS:Property>
    <DTS:Property DTS:Name="ForceExecValue">0</DTS:Property>
    <DTS:Property DTS:Name="ExecValue" DTS:DataType="3">0</DTS:Property>
    <DTS:Property DTS:Name="ForceExecutionResult">-1</DTS:Property>
    <DTS:Property DTS:Name="Disabled">0</DTS:Property>
    <DTS:Property DTS:Name="FailPackageOnFailure">0</DTS:Property>
    <DTS:Property DTS:Name="FailParentOnFailure">0</DTS:Property>
    <DTS:Property DTS:Name="MaxErrorCount">1</DTS:Property>
    <DTS:Property DTS:Name="ISOLevel">1048576</DTS:Property>
    <DTS:Property DTS:Name="LocaleID">-1</DTS:Property>

```

```

<DTS:Property DTS:Name="TransactionOption">1</DTS:Property>
<DTS:Property DTS:Name="DelayValidation">0</DTS:Property>
<DTS:Property DTS:Name="ObjectName">Get Stock Quote</DTS:Property>
<DTS:Property DTS:Name="DTSID">{6CA7FC7C-AB58-4C39-BD00-3F22B51AAB92}
</DTS:Property>
<DTS:Property DTS:Name="Description">Web Service Task</DTS:Property>
<DTS:Property DTS:Name="CreationName">
Microsoft.SqlServer.Dts.Tasks.WebServiceTask.WebServiceTask,
Microsoft.SqlServer.WebServiceTask, Version=10.0.0.0, Culture=neutral,
PublicKeyToken=89845dcd8080cc91
</DTS:Property>
<DTS:Property DTS:Name="DisableEventHandlers">0</DTS:Property>
<DTS:LoggingOptions>
<DTS:Property DTS:Name="LoggingMode">0</DTS:Property>
<DTS:Property DTS:Name="FilterKind">1</DTS:Property>
<DTS:Property DTS:Name="EventFilter" DTS:DataType="8">
</DTS:Property>
</DTS:LoggingOptions>
<DTS:PropertyExpression DTS:Name="WsdFile">
@[SAMPLES::ROOTWD] + "\\SampleData\\Service.wsdl"</DTS:PropertyExpression>
<DTS:ObjectData>
<WSTask:WebServiceTaskData
WSTask:ConnectionName="{2DA145FD-9C6E-487D-9A50-DD97C1D11763}"
WSTask:Service="LiveStockQuotes"
WSTask:WSDLFile="C:\USERS\username.DOMAIN\MY
DOCUMENTS\SSIS\BOOKSAMPLES2005\SampleData\Service.wsdl"
WSTask:OverwriteWSDLFile="True" WSTask:OutputType="File"
WSTask:OutputLocation="foo"
xmlns:WSTask="www.microsoft.com/sqlserver/dts/tasks/webservicetask">
<WSTask:MethodInfo WSTask:MethodName="liveMarketAsString"
WSTask:MessageName="LiveMarketAsString">
<WSTask:Documentation>&lt;h3&gt;This method can be used if a consumer is
unable to consume liveMarket method. The returned data is XML string.&lt;/h3&gt;
</WSTask:Documentation>
<WSTask:ParamInfo WSTask:Name="stockSymbol"
WSTask:Datatype="string"
WSTask:ParamType="Primitive"
WSTask:SeqNumber="0">
<WSTask:PrimitiveValue></WSTask:PrimitiveValue>
</WSTask:ParamInfo>
</WSTask:MethodInfo>
</WSTask:WebServiceTaskData>
</DTS:ObjectData>
</DTS:Executable>
<DTS:Executable DTS:ExecutableType=
"Microsoft.SqlServer.Dts.Tasks.ScriptTask.ScriptTask, Microsoft.SqlServer.ScriptTask,
Version=10.0.0.0, Culture=neutral, PublicKeyToken=89845dcd8080cc91"
DTS:ThreadHint="0">
<DTS:Property DTS:Name="ExecutionLocation">0</DTS:Property>
<DTS:Property DTS:Name="ExecutionAddress"></DTS:Property>
<DTS:Property DTS:Name="TaskContact"></DTS:Property>
<DTS:Property DTS:Name="ForceExecValue">0</DTS:Property>
<DTS:Property DTS:Name="ExecValue" DTS:DataType="3">0</DTS:Property>
<DTS:Property DTS:Name="ForceExecutionResult">-1</DTS:Property>
<DTS:Property DTS:Name="Disabled">0</DTS:Property>
<DTS:Property DTS:Name="FailPackageOnFailure">0</DTS:Property>
<DTS:Property DTS:Name="FailParentOnFailure">0</DTS:Property>
<DTS:Property DTS:Name="MaxErrorCount">1</DTS:Property>
<DTS:Property DTS:Name="ISOLevel">1048576</DTS:Property>
<DTS:Property DTS:Name="LocaleID">-1</DTS:Property>
<DTS:Property DTS:Name="TransactionOption">1</DTS:Property>
<DTS:Property DTS:Name="DelayValidation">0</DTS:Property>
<DTS:Property DTS:Name="ObjectName">Show Stock Price</DTS:Property>
<DTS:Property DTS:Name="DTSID">{325ba39d-e3ab-46cc-8f27-c28e9a5f9f8f}
</DTS:Property>
<DTS:Property DTS:Name="Description">Script Task</DTS:Property>
<DTS:Property DTS:Name="CreationName">
Microsoft.SqlServer.Dts.Tasks.ScriptTask.ScriptTask, Microsoft.SqlServer.ScriptTask,
Version=10.0.0.0, Culture=neutral, PublicKeyToken=89845dcd8080cc91

```



```

</DTS:Property>
  <DTS:Property DTS:Name="DisableEventHandlers">0</DTS:Property>
  <DTS:LoggingOptions>
    <DTS:Property DTS:Name="LoggingMode">0</DTS:Property>
    <DTS:Property DTS:Name="FilterKind">1</DTS:Property>
    <DTS:Property DTS:Name="EventFilter" DTS:DataType="8"></DTS:Property>
  </DTS:LoggingOptions>
  <DTS:ObjectData>
    <ScriptProject Name="ScriptTask_053aaalde6d84acab80050be0c42b6f2"
      VSTAMajorVersion="2" VSTAMinorVersion="1"
      Language="VisualBasic" EntryPoint="Main"
      ReadOnlyVariables="SAMPLES::STOCKQUOTE,SAMPLES::TICKERSYMBOL"
      ReadWriteVariables="">
    <ProjectItem Name="\my project\assemblyinfo.vb">
      <![CDATA[Imports System
Imports System.Reflection
Imports System.Runtime.InteropServices
' General Information about an assembly is controlled through the following
' set of attributes. Change these attribute values to modify the information
' associated with an assembly.
' Review the values of the assembly attributes
<Assembly: AssemblyTitle("ScriptTask_053aaalde6d84acab80050be0c42b6f2.vbproj")>
<Assembly: AssemblyDescription("")>
<Assembly: AssemblyCompany("MSIT")>
<Assembly: AssemblyProduct("ScriptTask_053aaalde6d84acab80050be0c42b6f2.vbproj")>
<Assembly: AssemblyCopyright("Copyright © MSIT 2008")>
<Assembly: AssemblyTrademark("")>
<Assembly: CLSCompliant(True)>
<Assembly: ComVisible(False)>
' The following GUID is for the ID of the typelib if this project is exposed to COM
<Assembly: Guid("e54931f7-e817-4314-a409-3cdc9702928a")>
' Version information for an assembly consists of the following four values:
'
'     Major Version
'     Minor Version
'     Build Number
'     Revision
'
' You can specify all the values or you can default the Build and Revision Numbers
' by using the '*' as shown below:
' <Assembly: AssemblyVersion("1.0.*")>
<Assembly: AssemblyVersion("1.0.0.0")>
<Assembly: AssemblyFileVersion("1.0.0.0")> ]]>
    </ProjectItem>
    <ProjectItem Name="\my project\settings.designer.vb">
      <![CDATA[-----
' <autogenerated>
'   This code was generated by a tool.
'
'   Changes to this file may cause incorrect behavior and will be lost if
'   the code is regenerated.
' </autogenerated>
-----
Option Strict Off
Option Explicit On
Partial Friend NotInheritable Class MySettings
  Inherits System.Configuration.ApplicationSettingsBase
  Private Shared m_Value As MySettings
  Private Shared m_SyncObject As Object = New Object
  <System.Diagnostics.DebuggerNonUserCode()> _
  Public Shared ReadOnly Property Value() As MySettings
    Get
      If (MySettings.m_Value Is Nothing) Then
        System.Threading.Monitor.Enter (MySettings.m_SyncObject)
        If (MySettings.m_Value Is Nothing) Then
          Try
            MySettings.m_Value = New MySettings
          Finally

```



```

<PropertyGroup Condition=" '$(Configuration)' == 'Release' ">
  <DefineConstants>
  </DefineConstants>
  <DefineDebug>>false</DefineDebug>
  <DefineTrace>>true</DefineTrace>
  <DebugSymbols>>false</DebugSymbols>
  <Optimize>>true</Optimize>
  <OutputPath>bin\</OutputPath>
  <RegisterForComInterop>>false</RegisterForComInterop>
  <RemoveIntegerChecks>>false</RemoveIntegerChecks>
  <NoWarn>42016,42017,42018,42019,42032</NoWarn>
</PropertyGroup>
<!-- This section enables pre- and post-build steps. However,
      it is recommended that MSBuild tasks be used instead of these properties.
-->
<PropertyGroup>
  <PreBuildEvent>
  </PreBuildEvent>
  <PostBuildEvent>
  </PostBuildEvent>
</PropertyGroup>
<!-- This sections specifies references for the project. -->
<ItemGroup>
  <Reference Include="Microsoft.SqlServer.ManagedDTS, Version=10.0.0.0, Culture=neutral,
PublicKeyToken=89845dcd8080cc91, processorArchitecture=MSIL" />
  <Reference Include="Microsoft.SqlServer.ScriptTask, Version=10.0.0.0, Culture=neutral,
PublicKeyToken=89845dcd8080cc91, processorArchitecture=MSIL" />
  <Reference Include="System" />
  <Reference Include="System.AddIn, Version=3.5.0.0, Culture=neutral,
PublicKeyToken=b77a5c561934e089, processorArchitecture=MSIL" />
  <Reference Include="System.Data" />
  <Reference Include="System.Windows.Forms" />
  <Reference Include="System.Xml" />
</ItemGroup>
<!-- Visual Basic supports Importing namespaces (equivalent to using statements in C#).-->
<ItemGroup>
  <Import Include="Microsoft.VisualBasic" />
  <Import Include="System" />
  <Import Include="System.Collections" />
  <Import Include="System.Data" />
  <Import Include="System.Diagnostics" />
  <Import Include="System.Windows.Forms" />
</ItemGroup>
<!-- This section defines the user source files that are part of the
      project.
      Compile - Specifies a source file to compile.
      EmbeddedResource - Specifies a .resx file for embedded resources.
      None - Specifies a file that is not to be passed to the compiler (for instance,
            a text file or XML file).
      AppDesigner - Specifies the directory where the application properties files can
                   be found.
-->
<ItemGroup>
  <AppDesigner Include="My Project\" />
  <Compile Include="My Project\AssemblyInfo.vb">
    <SubType>Code</SubType>
  </Compile>
  <EmbeddedResource Include="My Project\Resources.resx">
    <Generator>VbMyResourcesResXFileCodeGenerator</Generator>
    <LastGenOutput>Resources.Designer.vb</LastGenOutput>
    <CustomToolNamespace>My.Resources</CustomToolNamespace>
  </EmbeddedResource>
  <Compile Include="My Project\Resources.Designer.vb">
    <AutoGen>True</AutoGen>
    <DesignTime>True</DesignTime>
    <DependentUpon>Resources.resx</DependentUpon>
    <SubType>Code</SubType>
  </Compile>
  <None Include="My Project\Settings.settings">

```

```

    <Generator>SettingsSingleFileGenerator</Generator>
    <LastGenOutput>Settings.Designer.vb</LastGenOutput>
  </None>
  <Compile Include="My Project\Settings.Designer.vb">
    <AutoGen>True</AutoGen>
    <DependentUpon>Settings.settings</DependentUpon>
    <SubType>Code</SubType>
  </Compile>
  <Compile Include="ScriptMain.designer.vb">
    <DependentUpon>ScriptMain.Designer.xml</DependentUpon>
  </Compile>
  <Compile Include="ScriptMain.vb">
    <SubType>Code</SubType>
  </Compile>
  <None Include="ScriptMain.Designer.xml">
    <DependentUpon>ScriptMain.vb</DependentUpon>
  </None>
  <!-- Include the default configuration information and metadata files for the add-in.
    These files are copied to the build output directory when the project is
    built, and the path to the configuration file is passed to add-in on the command
    line when debugging.
  -->
</ItemGroup>
<!-- Include the build rules for a VB project.-->
<Import Project="$(MSBuildBinPath)\Microsoft.VisualBasic.targets" />
<!-- This section defines VSTA properties that describe the host-changeable project
properties. -->
  <ProjectExtensions>
    <VisualStudio>
      <FlavorProperties GUID="{A860303F-1F3F-4691-B57E-529FC101A107}">
        <ProjectProperties HostName="VSTAHostName" HostPackage="{C1B21C64-9E6F-4923-A89D-
9F958503C1CE}" ApplicationType="usd" Language="vb" TemplatesPath=""
DebugInfoExeName="#HKEY_LOCAL_MACHINE\SOFTWARE\Microsoft\VisualStudio\9.0\InstallDir#\devenv.
exe" />
        <Host Name="SSIS_ScriptTask">
          <HostItem Name="ScriptMain" Code="ScriptMain.vb" CanonicalName="ScriptMain"
DisplayName="ScriptMain" Blueprint="ScriptMain.Designer.xml"
GeneratedCode="ScriptMain.designer.vb" />
        </Host>
        <ProjectClient>
          <HostIdentifier>SSIS_ScriptTask</HostIdentifier>
        </ProjectClient>
      </FlavorProperties>
    </VisualStudio>
  </ProjectExtensions>
</Project>]]>
  </ProjectItem>
  <ProjectItem Name="\scriptmain.vb">
    <![CDATA[Imports System
Imports System.Data
Imports System.Math
Imports Microsoft.SqlServer.Dts.Runtime
Imports System.Xml
<System.AddIn.AddIn("ScriptMain", Version:="1.0", Publisher:="", Description:="")>
Partial Class ScriptMain
Private Sub ScriptMain_Startup(ByVal sender As Object, ByVal e As System.EventArgs)
End Sub
Private Sub ScriptMain_Shutdown(ByVal sender As Object, ByVal e As System.EventArgs)
Try
' Unlock variables from the read-only and read-write variable collection properties
If (Dts.Variables.Count <> 0) Then
Dts.Variables.Unlock()
End If
Catch ex As Exception
End Try
End Sub
Enum ScriptResults
Success = Microsoft.SqlServer.Dts.Runtime.DTSExecResult.Success
Failure = Microsoft.SqlServer.Dts.Runtime.DTSExecResult.Failure

```

```

End Enum
Public Sub Main()
    Dim last As String = New String("")
    Dim xmlDoc As XmlDocument = New XmlDocument()
    xmlDoc.LoadXml(Dts.Variables("SAMPLES::STOCKQUOTE").Value.ToString())
    If Not IsDBNull(xmlDoc) Then
        Dim list As XmlNodeList
        list = xmlDoc.DocumentElement.GetElementsByTagName("last_trade")
        If list.Count > 0 Then
            last = list.Item(0).InnerText
            MsgBox("The last price for the stock " +
Dts.Variables("SAMPLES::TICKERSYMBOL").Value.ToString() + ": is " + last.ToString(),
MsgBoxStyle.OkOnly, "Webservices Task Sample")
            Dts.TaskResult = ScriptResults.Success
        End If
    End If
End Sub
End Class]]>
</ProjectItem>
<ProjectItem Name="\my project\resources.designer.vb">
    <![CDATA[-----
-----
' <autogenerated>
'   This code was generated by a tool.
'
'   Changes to this file may cause incorrect behavior and will be lost if
'   the code is regenerated.
' </autogenerated>
-----
Option Strict Off
Option Explicit On
Namespace My.Resources
    '''<summary>
    '''   A strongly-typed resource class, for looking up localized strings, etc.
    '''</summary>
    'This class was auto-generated by the Strongly Typed Resource Builder
    'class via a tool like ResGen or Visual Studio.NET.
    'To add or remove a member, edit your .ResX file then rerun ResGen
    'with the /str option, or rebuild your VS project.
    Class MyResources
        Private Shared _resMgr As System.Resources.ResourceManager
        Private Shared _resCulture As System.Globalization.CultureInfo
        Friend Sub New()
            MyBase.New
        End Sub
        '''<summary>
        '''   Returns the cached ResourceManager instance used by this class.
        '''</summary>

<System.ComponentModel.EditorBrowsableAttribute(System.ComponentModel.EditorBrowsableState.Ad
vanced)>
        Public Shared ReadOnly Property ResourceManager() As System.Resources.ResourceManager
            Get
                If ( resMgr Is Nothing) Then
                    Dim temp As System.Resources.ResourceManager = New
System.Resources.ResourceManager("My.Resources.MyResources", GetType(MyResources).Assembly)
                    resMgr = temp
                End If
                Return resMgr
            End Get
        End Property
        '''<summary>
        '''   Overrides the current thread's CurrentUICulture property for all
        '''   resource lookups using this strongly typed resource class.
        '''</summary>

<System.ComponentModel.EditorBrowsableAttribute(System.ComponentModel.EditorBrowsableState.Ad
vanced)>
        Public Shared Property Culture() As System.Globalization.CultureInfo

```

```

        Get
            Return _resCulture
        End Get
        Set
            _resCulture = value
        End Set
    End Property
End Class
End Namespace]]>
</ProjectItem>
<ProjectItem Name="\scriptmain.designer.vb">
    <![CDATA[<System.CLSCompliantAttribute(False)> _
Partial Public Class ScriptMain
Inherits Microsoft.SqlServer.Dts.Tasks.ScriptTask.VSTARTScriptObjectModelBase
End Class]]>
</ProjectItem>
<ProjectItem Name="\my project\resources.resx">
    <![CDATA[<?xml version="1.0" encoding="utf-8"?>
<root>
    <!--
Microsoft ResX Schema
Version 2.0
The primary goals of this format is to allow a simple XML format
that is mostly human readable. The generation and parsing of the
various data types are done through the TypeConverter classes
associated with the data types.
Example:
... ado.net/XML headers & schema ...
<resheader name="resmimetype">text/microsoft-resx</resheader>
<resheader name="version">2.0</resheader>
<resheader name="reader">System.Resources.ResXResourceReader, System.Windows.Forms,
...</resheader>
<resheader name="writer">System.Resources.ResXResourceWriter, System.Windows.Forms,
...</resheader>
<data name="Name1"><value>this is my long string</value><comment>this is a
comment</comment></data>
<data name="Color1" type="System.Drawing.Color, System.Drawing">Blue</data>
<data name="Bitmap1" mimetype="application/x-microsoft.net.object.binary.base64">
    <value>[base64 mime encoded serialized .NET Framework object]</value>
</data>
<data name="Icon1" type="System.Drawing.Icon, System.Drawing" mimetype="application/x-
microsoft.net.object.bytearray.base64">
    <value>[base64 mime encoded string representing a byte array form of the .NET
Framework object]</value>
    <comment>This is a comment</comment>
</data>
There are any number of "resheader" rows that contain simple
name/value pairs.
Each data row contains a name, and value. The row also contains a
type or mimetype. Type corresponds to a .NET class that support
text/value conversion through the TypeConverter architecture.
Classes that don't support this are serialized and stored with the
mimetype set.
The mimetype is used for serialized objects, and tells the
ResXResourceReader how to depersist the object. This is currently not
extensible. For a given mimetype the value must be set accordingly:
Note - application/x-microsoft.net.object.binary.base64 is the format
that the ResXResourceWriter will generate, however the reader can
read any of the formats listed below.
mimetype: application/x-microsoft.net.object.binary.base64
value   : The object must be serialized with
          : System.Serialization.Formatters.Binary.BinaryFormatter
          : and then encoded with base64 encoding.
mimetype: application/x-microsoft.net.object.soap.base64
value   : The object must be serialized with
          : System.Runtime.Serialization.Formatters.Soap.SoapFormatter
          : and then encoded with base64 encoding.
mimetype: application/x-microsoft.net.object.bytearray.base64
value   : The object must be serialized into a byte array

```

```

        : using a System.ComponentModel.TypeConverter
        : and then encoded with base64 encoding.
-->
<xsd:schema id="root" xmlns="" xmlns:xsd="http://www.w3.org/2001/XMLSchema"
xmlns:msdata="urn:schemas-microsoft-com:xml-msdata">
  <xsd:element name="root" msdata:IsDataSet="true">
    <xsd:complexType>
      <xsd:choice maxOccurs="unbounded">
        <xsd:element name="metadata">
          <xsd:complexType>
            <xsd:sequence>
              <xsd:element name="value" type="xsd:string" minOccurs="0" />
            </xsd:sequence>
            <xsd:attribute name="name" type="xsd:string" />
            <xsd:attribute name="type" type="xsd:string" />
            <xsd:attribute name="mimetype" type="xsd:string" />
          </xsd:complexType>
        </xsd:element>
        <xsd:element name="assembly">
          <xsd:complexType>
            <xsd:attribute name="alias" type="xsd:string" />
            <xsd:attribute name="name" type="xsd:string" />
          </xsd:complexType>
        </xsd:element>
        <xsd:element name="data">
          <xsd:complexType>
            <xsd:sequence>
              <xsd:element name="value" type="xsd:string"
                minOccurs="0" msdata:Ordinal="1" />
              <xsd:element name="comment" type="xsd:string"
                minOccurs="0" msdata:Ordinal="2" />
            </xsd:sequence>
            <xsd:attribute name="name" type="xsd:string" msdata:Ordinal="1" />
            <xsd:attribute name="type" type="xsd:string" msdata:Ordinal="3" />
            <xsd:attribute name="mimetype" type="xsd:string" msdata:Ordinal="4" />
          </xsd:complexType>
        </xsd:element>
        <xsd:element name="resheader">
          <xsd:complexType>
            <xsd:sequence>
              <xsd:element name="value" type="xsd:string"
                minOccurs="0" msdata:Ordinal="1" />
            </xsd:sequence>
            <xsd:attribute name="name" type="xsd:string" use="required" />
          </xsd:complexType>
        </xsd:element>
      </xsd:choice>
    </xsd:complexType>
  </xsd:element>
</xsd:schema>
<resheader name="resmimetype">
  <value>text/microsoft-resx</value>
</resheader>
<resheader name="version">
  <value>2.0</value>
</resheader>
<resheader name="reader">
  <value>System.Resources.ResXResourceReader, System.Windows.Forms, Version=2.0.0.0,
Culture=neutral, PublicKeyToken=b77a5c561934e089</value>
</resheader>
<resheader name="writer">
  <value>System.Resources.ResXResourceWriter, System.Windows.Forms, Version=2.0.0.0,
Culture=neutral, PublicKeyToken=b77a5c561934e089</value>
</resheader>
</root>]]>
  </ProjectItem>
  <ProjectItem Name="\my project\settings.settings">
    <![CDATA[<?xml version='1.0' encoding='iso-8859-1'?>

```



```

    </control>
    </layoutobject>
    </ddsxmlobj>
    <property name="LogicalObject" value="{6CA7FC7C-AB58-4C39-BD00-3F22B51AAB92}"
vartype="8" />
    <property name="ShowConnectorSource" value="0" vartype="2" />
    </ddsxmlobj>
    </layoutobject>
    <shape groupshapeid="0" groupnode="0" />
    </ddscontrol>
    <ddscontrol controlprogid="DdsShapes.DdsObjectManagedBridge.2" tooltip="Script Task"
left="1635" top="5097" logicalid="6" controlid="2" masterid="0" hint1="0" hint2="0"
width="3598" height="1164" noresize="0" nomove="0" nodefaultattachpoints="0" autodrag="1"
usedefaulttiddshape="1" selectable="1" showselectionhandles="1" allownudging="1"
isannotation="0" dontautolayout="0" groupcollapsed="0" tabstop="1" visible="1"
snaptogrid="0">
    <control>
    <ddsxmlobjectstreaminitwrapper binary="000800000e0e00008c040000" />
    </control>
    </layoutobject>
    </ddsxmlobj>
    <property name="LogicalObject" value="{325ba39d-e3ab-46cc-8f27-c28e9a5f9f8f}"
vartype="8" />
    <property name="ShowConnectorSource" value="0" vartype="2" />
    </ddsxmlobj>
    </layoutobject>
    <shape groupshapeid="0" groupnode="0" />
    </ddscontrol>
    <ddscontrol controlprogid="MSDDS.Polyline" left="3035" top="3457" logicalid="7"
controlid="3" masterid="0" hint1="0" hint2="0" width="799" height="2140" noresize="0"
nomove="0" nodefaultattachpoints="1" autodrag="0" usedefaulttiddshape="0" selectable="1"
showselectionhandles="0" allownudging="1" isannotation="0" dontautolayout="0"
groupcollapsed="0" tabstop="1" visible="1" snaptogrid="0">
    <control>
    <ddsxmlobj>
    <polyline endtypedst="3" endtypesrc="1" usercolor="32768" linestyle="0"
linerender="2" customendtypedstid="0" customendtypesrcid="0" adornsvisible="1" />
    </ddsxmlobj>
    </control>
    </layoutobject>
    </ddsxmlobj>
    <property name="LogicalObject" value="{F2196320-9345-4773-9EBD-06F12CDDFB06}"
vartype="8" />
    <property name="Virtual" value="0" vartype="11" />
    <property name="VisibleAP" value="0" vartype="3" />
    </ddsxmlobj>
    </layoutobject>
    <connector lineroutestyle="Microsoft.DataWarehouse.Layout.GraphLayout100"
sourceid="1" destid="2" sourceattachpoint="9" destattachpoint="6" segmenteditmode="0"
bendpointeditmode="0" bendpointvisibility="2" relatedid="0" virtual="0">
    <point x="3434" y="3856" />
    <point x="3434" y="5097" />
    </connector>
    </ddscontrol>

</dds> </dwd:Layout> </dwd:PersistedViewPortTop> 1297 </dwd:PersistedViewPort
Top> </dwd:DtsControlFlowDiagram> </Package>
</DTS:Property>
<DTS:Property DTS:Name="Namespace">dts-designer-1.0</DTS:Property>
<DTS:Property DTS:Name="ObjectName">
{6BC04190-25CC-422A-92BE-68ACBD6F59E8}</DTS:Property>
<DTS:Property DTS:Name="DTSID">
{30E4D8CF-FF88-4DBD-892E-D068D5ED9A6C}</DTS:Property>
<DTS:Property DTS:Name="Description"></DTS:Property>
<DTS:Property DTS:Name="CreationName"></DTS:Property>
</DTS:PackageVariable>
<DTS:PackageVariable>
<DTS:Property DTS:Name="PackageVariableValue" DTS:DataType="8">
    <PrecedenceConstraint xmlns:xsd="http://www.w3.org/2001/XMLSchema"

```

```

xmlns:xsi="http://www.w3.org/2001/XMLSchema-instance"
xmlns:ddl2="http://schemas.microsoft.com/analysisservices/2003/engine/2"
xmlns:ddl2_2="http://schemas.microsoft.com/analysisservices/2003/engine/2/2"
xmlns:ddl100_100="http://schemas.microsoft.com/analysisservices/2008/engine/100/100"

xmlns:dwd="http://schemas.microsoft.com/DataWarehouse/Designer/1.0"&gt;&lt;dwd:EvalOp&gt;Constraint&lt;/dwd:EvalOp&gt;&lt;/PrecedenceConstraint&gt;
</DTS:Property>
<DTS:Property DTS:Name="Namespace">dts-designer-1.0</DTS:Property>
<DTS:Property DTS:Name="ObjectName">
  {F2196320-9345-4773-9EBD-06F12CDDFB06}</DTS:Property>
<DTS:Property DTS:Name="DTSID">
  {F52F6517-D928-4565-8E79-89F314FFDF21}</DTS:Property>
<DTS:Property DTS:Name="Description"></DTS:Property>
<DTS:Property DTS:Name="CreationName"></DTS:Property>
</DTS:PackageVariable>
<DTS:PackageVariable>
  <DTS:Property DTS:Name="PackageVariableValue" DTS:DataType="8">
    &lt;Package xmlns:xsd="http://www.w3.org/2001/XMLSchema"
      xmlns:xsi="http://www.w3.org/2001/XMLSchema-instance"
      xmlns:ddl2="http://schemas.microsoft.com/analysisservices/2003/engine/2"
      xmlns:ddl2_2="http://schemas.microsoft.com/analysisservices/2003/engine/2/2"
      xmlns:ddl100_100="http://schemas.microsoft.com/analysisservices/2008/engine/100/100"

      xmlns:dwd="http://schemas.microsoft.com/DataWarehouse/Designer/1.0"&gt;&lt;dwd:DtsControlFlowDiagram&gt;&lt;/dwd:BoundingLeft&gt;1000&lt;/dwd:BoundingLeft&gt;&lt;/dwd:BoundingTop&gt;2297&lt;/dwd:BoundingTop&gt;&lt;/dwd:Layout&gt;&lt;/dds&gt;
      &lt;diagram fontclsid="{0BE35203-8F91-11CE-9DE3-00AA004BB851}"
        mouseiconclsid="{0BE35204-8F91-11CE-9DE3-00AA004BB851}"
        defaultlayout="Microsoft.DataWarehouse.Layout.GraphLayout100"
        defaultlineroute="Microsoft.DataWarehouse.Layout.GraphLayout100" version="7" nextobject="12"
        scale="100" pagebreakanchorx="0" pagebreakanchory="0" pagebreaksizex="0" pagebreaksizey="0"
        scrollleft="0" scrolltop="1297" gridx="150" gridy="150" marginx="1000" marginy="1000"
        zoom="100" x="24156" y="8440" backcolor="15334399" defaultpersistence="2"
        PrintPageNumbersMode="3" PrintMarginTop="0" PrintMarginBottom="635" PrintMarginLeft="0"
        PrintMarginRight="0" marqueeeselectionmode="1" mousepointer="0" snaptogrid="0"
        autotypeannotation="1" showscrollbars="0" viewpagebreaks="0"
        donotforceconnectorsbehindshapes="1" backpictureclsid="{00000000-0000-0000-0000-000000000000}"&gt;
          &lt;font&gt;
            &lt;ddsxmlobjectstreamwrapper binary="01010000900180380100065461686f6d61" /&gt;
          &lt;/font&gt;
          &lt;mouseicon&gt;
            &lt;ddsxmlobjectstreamwrapper binary="6c74000000000000" /&gt;
          &lt;/mouseicon&gt;
          &lt;/diagram&gt;
          &lt;layoutmanager&gt;
            &lt;ddsxmlobj /&gt;
          &lt;/layoutmanager&gt;
          &lt;ddscontrol controlprogid="DdsShapes.DdsObjectManagedBridge.2" tooltip="Web Service Task" left="1000" top="2692" logicalid="5" controlid="1" masterid="0" hint1="0" hint2="0" width="4869" height="1164" noresize="0" nomove="0" nodefaultattachpoints="0" autodrag="1" usedefaultidshape="1" selectable="1" showselectionhandles="1" allownudging="1" isannotation="0" dontautolayout="0" groupcollapsed="0" tabstop="1" visible="1" snaptogrid="0"&gt;
            &lt;control&gt;
              &lt;ddsxmlobjectstreaminitwrapper binary="00080000051300008c040000" /&gt;
            &lt;/control&gt;
            &lt;layoutobject&gt;
              &lt;ddsxmlobj&gt;
                &lt;property name="LogicalObject" value="{6CA7FC7C-AB58-4C39-BD00-3F22B51AAB92}" vartype="8" /&gt;
                &lt;property name="ShowConnectorSource" value="0" vartype="2" /&gt;
              &lt;/ddsxmlobj&gt;
            &lt;/layoutobject&gt;
            &lt;shape groupshapeid="0" groupnode="0" /&gt;
          &lt;/ddscontrol&gt;
          &lt;ddscontrol controlprogid="DdsShapes.DdsObjectManagedBridge.2" tooltip="Script Task" left="1635" top="5097" logicalid="6" controlid="2" masterid="0" hint1="0" hint2="0"

```

```

width="3598" height="1164" noresize="0" nomove="0" nodefaultattachpoints="0" autodrag="1"
usedefaultiddshape="1" selectable="1" showselectionhandles="1" allownudging="1"
isannotation="0" dontautolayout="0" groupcollapsed="0" tabstop="1" visible="1"
snaptogrid="0"&gt;
  &lt;control&gt;
    &lt;ddsxmlobjectstreaminitwrapper binary="000800000e0e00008c040000" /&gt;
  &lt;/control&gt;
  &lt;layoutobject&gt;
    &lt;ddsxmlobj&gt;
      &lt;property name="LogicalObject" value="{325ba39d-e3ab-46cc-8f27-c28e9a5f9f8f}"
vartype="8" /&gt;
      &lt;property name="ShowConnectorSource" value="0" vartype="2" /&gt;
    &lt;/ddsxmlobj&gt;
  &lt;/layoutobject&gt;
  &lt;shape groupshapeid="0" groupnode="0" /&gt;
  &lt;/ddscontrol&gt;
  &lt;ddscontrol controlprogid="MSDDS.Polyline" left="3035" top="3457" logicalid="7"
controlid="3" masterid="0" hint1="0" hint2="0" width="799" height="2140" noresize="0"
nomove="0" nodefaultattachpoints="1" autodrag="0" usedefaultiddshape="0" selectable="1"
showselectionhandles="0" allownudging="1" isannotation="0" dontautolayout="0"
groupcollapsed="0" tabstop="1" visible="1" snaptogrid="0"&gt;
    &lt;control&gt;
      &lt;ddsxmlobj&gt;
        &lt;polyline endtypedst="3" endtypesrc="1" usercolor="32768" linestyle="0"
linerender="2" customendtypedstid="0" customendtypesrcid="0" adornsvvisible="1" /&gt;
      &lt;/ddsxmlobj&gt;
    &lt;/control&gt;
  &lt;layoutobject&gt;
    &lt;ddsxmlobj&gt;
      &lt;property name="LogicalObject" value="{F2196320-9345-4773-9EBD-06F12CDDFB06}"
vartype="8" /&gt;
      &lt;property name="Virtual" value="0" vartype="11" /&gt;
      &lt;property name="VisibleAP" value="0" vartype="3" /&gt;
    &lt;/ddsxmlobj&gt;
  &lt;/layoutobject&gt;
  &lt;connector lineroutestyle="Microsoft.DataWarehouse.Layout.GraphLayout100"
sourceid="1" destid="2" sourceattachpoint="9" destattachpoint="6" segmenteditmode="0"
bendpointeditmode="0" bendpointvisibility="2" relatedid="0" virtual="0"&gt;
    &lt;point x="3434" y="3856" /&gt;
    &lt;point x="3434" y="5097" /&gt;
  &lt;/connector&gt;
  &lt;/ddscontrol&gt;

&lt;/dds&gt; &lt;/dwd:Layout&gt; &lt;/dwd:PersistedViewPortTop&gt; 1297&lt;/dwd:PersistedViewPort
Top&gt; &lt;/dwd:DtsControlFlowDiagram&gt; &lt;/Package&gt;
</DTS:Property>
<DTS:Property DTS:Name="Namespace">dts-designer-1.0</DTS:Property>
<DTS:Property DTS:Name="ObjectName">package-diagram</DTS:Property>
<DTS:Property DTS:Name="DTSID">{1A9A57C2-7F96-4E13-9EAC-FA1B0F0E7E46}</DTS:Property>
<DTS:Property DTS:Name="Description"></DTS:Property>
<DTS:Property DTS:Name="CreationName"></DTS:Property>
</DTS:PackageVariable>
</DTS:Executable>

```

3.3 Custom Component

The following package file contains a custom component. The package file deviates from the specified XSD because of the presence the custom component as described here and as shown in the full package file below.

The **ExecutableType** attribute value is a custom value that is specified by the custom component, as follows.

```
"CustomFileCopyTask.CustomFileCopy, CustomFileCopyTask, Version=1.0.0.0, Culture=neutral,
PublicKeyToken=6d9410f0409e8e15"
```

The **componentClassID** attribute value is a custom value that is specified by the custom component and is not present in the specified XSD.

```
<component id="1" name="CalendarTransform"
  componentClassID="{BF01D463-7089-41EE-8F05-0A6DC17CE633}"
  description="Generates Roman, financial, reporting, manufacturing and IOS8601
calendar data."
  localeId="-1" usesDispositions="false"
  validateExternalMetadata="True" version="0"
  pipelineVersion="0" contactInfo="">
```

Each of the following properties is not a specified property in the XSD and is a custom value that is specified defined by the custom component.

```
<property id="5" name="First day of week"
  dataType="System.String" state="default"
  isArray="false" description="Start day of logical week"
  typeConverter="Microsoft.Samples.SqlServer.Dts.DataFlow.FirstDayOfWeekConverter,
CalendarTransform, Version=1.0.0.0, Culture=neutral, PublicKeyToken=e9fac57941009407"
  UITypeEditor="" containsID="false"
  expressionType="None">Tuesday</property>

<property id="6" name="Fiscal definition"
  dataType="System.String" state="default"
  isArray="false" description=
  "Parameter list defining fiscal calendar"
  typeConverter="" UITypeEditor="" containsID="false"
  expressionType="None">StartDay=1,StartMonth=1,YearDelta=0
</property>

<property id="7" name="Manufacturing definition"
  dataType="System.String" state="default" isArray="false"
  description="Parameter list defining manufacturing calendar"
  typeConverter="" UITypeEditor="" containsID="false"
  expressionType="None">StartMonth=1,StartWeek=1,Quarter=1
</property>
  <property id="8" name="Reporting definition" dataType=
  "System.String" state="default" isArray="false"
  description="Parameter list defining reporting calendar"
  typeConverter="" UITypeEditor="" containsID="false"
  expressionType="None">StartMonth=1,StartWeek=1,Pattern=445
</property>
    <property id="167" name="Attribute Type" dataType=
    "System.String" state="default" isArray=
    "false" description="Time period attribute type"
    typeConverter=
    "Microsoft.Samples.SqlServer.Dts.DataFlow.TimeAttributeTypeConverter,
CalendarTransform, Version=1.0.0.0, Culture=neutral, PublicKeyToken=e9fac57941009407"
    UITypeEditor="" containsID="false"
    expressionType="None">Days</property>
    <property id="168" name="Attribute Part" dataType=
    "System.String" state="default" isArray=
    "false" description="Time period attribute part"
    typeConverter=
    "Microsoft.Samples.SqlServer.Dts.DataFlow.TimeAttributePartConverter,
CalendarTransform, Version=1.0.0.0, Culture=neutral, PublicKeyToken=e9fac57941009407"
    UITypeEditor="" containsID="false"
    expressionType="None">Key</property>
    <property id="169" name="Format" dataType=
```

```

"System.String" state="default"
isArray="false" description=
"Optional format string (output coerced to string)"
typeConverter="" UITypeEditor=""
containsID="false" expressionType="None">
</property>

```

For detailed information about how custom components affect the defined DTSX structure, see [Custom Component](#).

```

<?xml version="1.0"?>
<DTS:Executable xmlns:DTS="www.microsoft.com/SqlServer/Dts"
  DTS:ExecutableType="SSIS.Package.2">
  <DTS:Property DTS:Name="PackageFormatVersion">2</DTS:Property>
  <DTS:Property DTS:Name="VersionComments"></DTS:Property>
  <DTS:Property DTS:Name="CreatorName">DOMAIN\username</DTS:Property>
  <DTS:Property DTS:Name="CreatorComputerName">KEVIRT01</DTS:Property>
  <DTS:Property DTS:Name="CreationDate" DTS:DataType="7">
    11/20/2007 11:29:04 AM</DTS:Property>
  <DTS:Property DTS:Name="PackageType">5</DTS:Property>
  <DTS:Property DTS:Name="ProtectionLevel">1</DTS:Property>
  <DTS:Property DTS:Name="MaxConcurrentExecutables">-1</DTS:Property>
  <DTS:Property DTS:Name="PackagePriorityClass">0</DTS:Property>
  <DTS:Property DTS:Name="VersionMajor">1</DTS:Property>
  <DTS:Property DTS:Name="VersionMinor">0</DTS:Property>
  <DTS:Property DTS:Name="VersionBuild">5</DTS:Property>
  <DTS:Property DTS:Name="VersionGUID">
    {18F30840-EE8E-4119-B16D-85D3DC24B6DC}</DTS:Property>
  <DTS:Property DTS:Name="EnableConfig">0</DTS:Property>
  <DTS:Property DTS:Name="CheckpointFileName"></DTS:Property>
  <DTS:Property DTS:Name="SaveCheckpoints">0</DTS:Property>
  <DTS:Property DTS:Name="CheckpointUsage">0</DTS:Property>
  <DTS:Property DTS:Name="SuppressConfigurationWarnings">0</DTS:Property>
  <DTS:Property DTS:Name="ForceExecValue">0</DTS:Property>
  <DTS:Property DTS:Name="ExecValue" DTS:DataType="3">0</DTS:Property>
  <DTS:Property DTS:Name="ForceExecutionResult">-1</DTS:Property>
  <DTS:Property DTS:Name="Disabled">0</DTS:Property>
  <DTS:Property DTS:Name="FailPackageOnFailure">0</DTS:Property>
  <DTS:Property DTS:Name="FailParentOnFailure">0</DTS:Property>
  <DTS:Property DTS:Name="MaxErrorCount">1</DTS:Property>
  <DTS:Property DTS:Name="ISOLevel">1048576</DTS:Property>
  <DTS:Property DTS:Name="LocaleID">1033</DTS:Property>
  <DTS:Property DTS:Name="TransactionOption">1</DTS:Property>
  <DTS:Property DTS:Name="DelayValidation">0</DTS:Property>
  <DTS:Property DTS:Name="ObjectName">Package</DTS:Property>
  <DTS:Property DTS:Name="DTSID">{61EDFABA-B54F-4EFE-9FF2-DABDD94B9D51}
</DTS:Property>
  <DTS:Property DTS:Name="Description"></DTS:Property>
  <DTS:Property DTS:Name="CreationName">MSDTS.Package.1</DTS:Property>
  <DTS:Property DTS:Name="DisableEventHandlers">0</DTS:Property>
  <DTS:ConnectionManager>
    <DTS:Property DTS:Name="DelayValidation">0</DTS:Property>
    <DTS:Property DTS:Name="ObjectName">Flat File Connection Manager
  </DTS:Property>
  <DTS:Property DTS:Name="DTSID">{4F717107-732B-4C1B-AAF5-A5A31B6FECE8}
  </DTS:Property>
  <DTS:Property DTS:Name="Description"></DTS:Property>
  <DTS:Property DTS:Name="CreationName">FLATFILE</DTS:Property>
  <DTS:ObjectData>
    <DTS:ConnectionManager>
      <DTS:Property DTS:Name="FileUsageType">0</DTS:Property>
      <DTS:Property DTS:Name="Format">FixedWidth</DTS:Property>
      <DTS:Property DTS:Name="LocaleID">1033</DTS:Property>
      <DTS:Property DTS:Name="Unicode">0</DTS:Property>
      <DTS:Property DTS:Name="HeaderRowsToSkip">0</DTS:Property>
      <DTS:Property DTS:Name="HeaderRowDelimiter"

```



```

        xml:space="preserve">_x000D_x000A_</DTS:Property>
<DTS:Property DTS:Name="ColumnNamesInFirstDataRow">0
</DTS:Property>
<DTS:Property DTS:Name="RowDelimiter" xml:space="preserve">
</DTS:Property>
<DTS:Property DTS:Name="DataRowsToSkip">0</DTS:Property>
<DTS:Property DTS:Name="TextQualifier">&lt;none&gt;</DTS:Property>
<DTS:Property DTS:Name="CodePage">1252</DTS:Property>
<DTS:Property DTS:Name="ConnectionString">
C:\Documents and Settings\Administrator\Local Settings\Temp\fl.txt
</DTS:Property>
<DTS:FlatFileColumn>
  <DTS:Property DTS:Name="ColumnType">FixedWidth</DTS:Property>
  <DTS:Property DTS:Name="ColumnDelimiter" xml:space="preserve">
  </DTS:Property>
  <DTS:Property DTS:Name="ColumnWidth">24</DTS:Property>
  <DTS:Property DTS:Name="MaximumWidth">0</DTS:Property>
  <DTS:Property DTS:Name="DataType">4</DTS:Property>
  <DTS:Property DTS:Name="DataPrecision">0</DTS:Property>
  <DTS:Property DTS:Name="DataScale">0</DTS:Property>
  <DTS:Property DTS:Name="TextQualified">-1</DTS:Property>
  <DTS:Property DTS:Name="ObjectName">Column 0</DTS:Property>
  <DTS:Property DTS:Name="DTSID">
    {5EC860DF-B362-4219-A057-FFB39B58905E}</DTS:Property>
  <DTS:Property DTS:Name="Description"></DTS:Property>
  <DTS:Property DTS:Name="CreationName"></DTS:Property>
</DTS:FlatFileColumn>
<DTS:FlatFileColumn>
  <DTS:Property DTS:Name="ColumnType">FixedWidth</DTS:Property>
  <DTS:Property DTS:Name="ColumnDelimiter" xml:space="preserve">
  </DTS:Property>
  <DTS:Property DTS:Name="ColumnWidth">3</DTS:Property>
  <DTS:Property DTS:Name="MaximumWidth">3</DTS:Property>
  <DTS:Property DTS:Name="DataType">129</DTS:Property>
  <DTS:Property DTS:Name="DataPrecision">0</DTS:Property>
  <DTS:Property DTS:Name="DataScale">0</DTS:Property>
  <DTS:Property DTS:Name="TextQualified">-1</DTS:Property>
  <DTS:Property DTS:Name="ObjectName">Column 1</DTS:Property>
  <DTS:Property DTS:Name="DTSID">
{7657CF3B-099A-4DE3-9790-257BC29911D8}</DTS:Property>
  <DTS:Property DTS:Name="Description"></DTS:Property>
  <DTS:Property DTS:Name="CreationName"></DTS:Property>
</DTS:FlatFileColumn>
<DTS:FlatFileColumn>
  <DTS:Property DTS:Name="ColumnType">FixedWidth</DTS:Property>
  <DTS:Property DTS:Name="ColumnDelimiter" xml:space="preserve">
  </DTS:Property>
  <DTS:Property DTS:Name="ColumnWidth">24</DTS:Property>
  <DTS:Property DTS:Name="MaximumWidth">0</DTS:Property>
  <DTS:Property DTS:Name="DataType">4</DTS:Property>
  <DTS:Property DTS:Name="DataPrecision">0</DTS:Property>
  <DTS:Property DTS:Name="DataScale">0</DTS:Property>
  <DTS:Property DTS:Name="TextQualified">-1</DTS:Property>
  <DTS:Property DTS:Name="ObjectName">Column 3</DTS:Property>
  <DTS:Property DTS:Name="DTSID">
{384A703C-66ED-4ACB-9A65-AE1218D1B72F}</DTS:Property>
  <DTS:Property DTS:Name="Description"></DTS:Property>
  <DTS:Property DTS:Name="CreationName"></DTS:Property>
</DTS:FlatFileColumn>
<DTS:FlatFileColumn>
  <DTS:Property DTS:Name="ColumnType">FixedWidth</DTS:Property>
  <DTS:Property DTS:Name="ColumnDelimiter" xml:space="preserve">
  </DTS:Property>
  <DTS:Property DTS:Name="ColumnWidth">23</DTS:Property>
  <DTS:Property DTS:Name="MaximumWidth">0</DTS:Property>
  <DTS:Property DTS:Name="DataType">7</DTS:Property>
  <DTS:Property DTS:Name="DataPrecision">0</DTS:Property>
  <DTS:Property DTS:Name="DataScale">0</DTS:Property>
  <DTS:Property DTS:Name="TextQualified">-1</DTS:Property>

```

```

    <DTS:Property DTS:Name="ObjectName">DateColumn</DTS:Property>
    <DTS:Property DTS:Name="DTSID">
{E58B1BF2-BBC1-4C4E-84CE-EDB786620D1A}</DTS:Property>
    <DTS:Property DTS:Name="Description"></DTS:Property>
    <DTS:Property DTS:Name="CreationName"></DTS:Property>
  </DTS:FlatFileColumn>
  <DTS:FlatFileColumn>
    <DTS:Property DTS:Name="ColumnType">FixedWidth</DTS:Property>
    <DTS:Property DTS:Name="ColumnDelimiter" xml:space="preserve">
  </DTS:Property>
    <DTS:Property DTS:Name="ColumnWidth">30</DTS:Property>
    <DTS:Property DTS:Name="MaximumWidth">0</DTS:Property>
    <DTS:Property DTS:Name="DataType">135</DTS:Property>
    <DTS:Property DTS:Name="DataPrecision">0</DTS:Property>
    <DTS:Property DTS:Name="DataScale">0</DTS:Property>
    <DTS:Property DTS:Name="TextQualified">-1</DTS:Property>
    <DTS:Property DTS:Name="ObjectName">Column</DTS:Property>
    <DTS:Property DTS:Name="DTSID">
{42D205F3-5045-4220-8039-2D901E25061A}</DTS:Property>
    <DTS:Property DTS:Name="Description"></DTS:Property>
    <DTS:Property DTS:Name="CreationName"></DTS:Property>
  </DTS:FlatFileColumn>
</DTS:ConnectionManager>
</DTS:ObjectData>
</DTS:ConnectionManager>
<DTS:ConnectionManager>
  <DTS:Property DTS:Name="DelayValidation">0</DTS:Property>
  <DTS:Property DTS:Name="ObjectName">Sample Flat connection
</DTS:Property>
  <DTS:Property DTS:Name="DTSID">{00F5DC11-75D6-49FC-BE02-C4984643F39A}
</DTS:Property>
  <DTS:Property DTS:Name="Description"></DTS:Property>
  <DTS:Property DTS:Name="CreationName">FLATFILE</DTS:Property>
<DTS:ObjectData>
  <DTS:ConnectionManager>
    <DTS:Property DTS:Name="FileUsageType">0</DTS:Property>
    <DTS:Property DTS:Name="Format">Delimited</DTS:Property>
    <DTS:Property DTS:Name="LocaleID">1033</DTS:Property>
    <DTS:Property DTS:Name="Unicode">0</DTS:Property>
    <DTS:Property DTS:Name="HeaderRowsToSkip">0</DTS:Property>
    <DTS:Property DTS:Name="HeaderRowDelimiter"
  xml:space="preserve"> x000D x000A </DTS:Property>
    <DTS:Property DTS:Name="ColumnNamesInFirstDataRow">0</DTS:Property>
    <DTS:Property DTS:Name="RowDelimiter" xml:space="preserve">
  </DTS:Property>
    <DTS:Property DTS:Name="DataRowsToSkip">0</DTS:Property>
    <DTS:Property DTS:Name="TextQualifier">&lt;none&gt;</DTS:Property>
    <DTS:Property DTS:Name="CodePage">1252</DTS:Property>
    <DTS:Property DTS:Name="ConnectionString">
C:\Documents and Settings\Administrator\Local Settings\Temp\t1.txt
  </DTS:Property>
  <DTS:FlatFileColumn>
    <DTS:Property DTS:Name="ColumnType">Delimited</DTS:Property>
    <DTS:Property DTS:Name="ColumnDelimiter"
  xml:space="preserve">_x0009_</DTS:Property>
    <DTS:Property DTS:Name="ColumnWidth">0</DTS:Property>
    <DTS:Property DTS:Name="MaximumWidth">0</DTS:Property>
    <DTS:Property DTS:Name="DataType">4</DTS:Property>
    <DTS:Property DTS:Name="DataPrecision">0</DTS:Property>
    <DTS:Property DTS:Name="DataScale">0</DTS:Property>
    <DTS:Property DTS:Name="TextQualified">-1</DTS:Property>
    <DTS:Property DTS:Name="ObjectName">Column 0</DTS:Property>
    <DTS:Property DTS:Name="DTSID">
{B595CAF1-EFA8-4F91-9813-E46E9BA0B23C}</DTS:Property>
    <DTS:Property DTS:Name="Description"></DTS:Property>
    <DTS:Property DTS:Name="CreationName"></DTS:Property>
  </DTS:FlatFileColumn>
  <DTS:FlatFileColumn>
    <DTS:Property DTS:Name="ColumnType">Delimited</DTS:Property>

```

```

        <DTS:Property DTS:Name="ColumnDelimiter"
            xml:space="preserve">_x0009_</DTS:Property>
        <DTS:Property DTS:Name="ColumnWidth">0</DTS:Property>
        <DTS:Property DTS:Name="MaximumWidth">3</DTS:Property>
        <DTS:Property DTS:Name="DataType">129</DTS:Property>
        <DTS:Property DTS:Name="DataPrecision">0</DTS:Property>
        <DTS:Property DTS:Name="DataScale">0</DTS:Property>
        <DTS:Property DTS:Name="TextQualified">-1</DTS:Property>
        <DTS:Property DTS:Name="ObjectName">Column 1</DTS:Property>
        <DTS:Property DTS:Name="DTSID">
{68CD7506-DD5C-4D29-BB9E-E35F3AFCE310}</DTS:Property>
        <DTS:Property DTS:Name="Description"></DTS:Property>
        <DTS:Property DTS:Name="CreationName"></DTS:Property>
    </DTS:FlatFileColumn>
    <DTS:FlatFileColumn>
        <DTS:Property DTS:Name="ColumnType">Delimited</DTS:Property>
        <DTS:Property DTS:Name="ColumnDelimiter"
            xml:space="preserve">_x0009_</DTS:Property>
        <DTS:Property DTS:Name="ColumnWidth">0</DTS:Property>
        <DTS:Property DTS:Name="MaximumWidth">0</DTS:Property>
        <DTS:Property DTS:Name="DataType">7</DTS:Property>
        <DTS:Property DTS:Name="DataPrecision">0</DTS:Property>
        <DTS:Property DTS:Name="DataScale">0</DTS:Property>
        <DTS:Property DTS:Name="TextQualified">-1</DTS:Property>
        <DTS:Property DTS:Name="ObjectName">DateColumn</DTS:Property>
        <DTS:Property DTS:Name="DTSID">
{95B6A9B8-2732-42A5-8091-7751E2CBE35A}</DTS:Property>
        <DTS:Property DTS:Name="Description"></DTS:Property>
        <DTS:Property DTS:Name="CreationName"></DTS:Property>
    </DTS:FlatFileColumn>
    <DTS:FlatFileColumn>
        <DTS:Property DTS:Name="ColumnType">Delimited</DTS:Property>
        <DTS:Property DTS:Name="ColumnDelimiter"
            xml:space="preserve">_x000D_</DTS:Property>
        <DTS:Property DTS:Name="ColumnWidth">0</DTS:Property>
        <DTS:Property DTS:Name="MaximumWidth">0</DTS:Property>
        <DTS:Property DTS:Name="DataType">4</DTS:Property>
        <DTS:Property DTS:Name="DataPrecision">0</DTS:Property>
        <DTS:Property DTS:Name="DataScale">0</DTS:Property>
        <DTS:Property DTS:Name="TextQualified">-1</DTS:Property>
        <DTS:Property DTS:Name="ObjectName">Column 3</DTS:Property>
        <DTS:Property DTS:Name="DTSID">
{A3C6406D-E017-44A7-A217-8171E5E04326}</DTS:Property>
        <DTS:Property DTS:Name="Description"></DTS:Property>
        <DTS:Property DTS:Name="CreationName"></DTS:Property>
    </DTS:FlatFileColumn>
</DTS:ConnectionManager>
</DTS:ObjectData>
</DTS:ConnectionManager>
<DTS:LoggingOptions>
    <DTS:Property DTS:Name="LoggingMode">0</DTS:Property>
    <DTS:Property DTS:Name="FilterKind">1</DTS:Property>
    <DTS:Property DTS:Name="EventFilter" DTS:DataType="8"></DTS:Property>
</DTS:LoggingOptions>
<DTS:Executable
    DTS:ExecutableType=
"CustomFileCopyTask.CustomFileCopy, CustomFileCopyTask, Version=1.0.0.0, Culture=neutral,
PublicKeyToken=6d9410f0409e8e15"
    DTS:ThreadHint="0">
    <DTS:Property DTS:Name="ExecutionLocation">0</DTS:Property>
    <DTS:Property DTS:Name="ExecutionAddress"></DTS:Property>
    <DTS:Property DTS:Name="TaskContact">
        CustomFileCopyTask, Copyright (c) Microsoft</DTS:Property>
    <DTS:Property DTS:Name="ForceExecValue">0</DTS:Property>
    <DTS:Property DTS:Name="ExecValue" DTS:DataType="3">0</DTS:Property>
    <DTS:Property DTS:Name="ForceExecutionResult">-1</DTS:Property>
    <DTS:Property DTS:Name="Disabled">0</DTS:Property>
    <DTS:Property DTS:Name="FailPackageOnFailure">0</DTS:Property>
    <DTS:Property DTS:Name="FailParentOnFailure">0</DTS:Property>

```

```

<DTS:Property DTS:Name="MaxErrorCount">1</DTS:Property>
<DTS:Property DTS:Name="ISOLevel">1048576</DTS:Property>
<DTS:Property DTS:Name="LocaleID">-1</DTS:Property>
<DTS:Property DTS:Name="TransactionOption">1</DTS:Property>
<DTS:Property DTS:Name="DelayValidation">0</DTS:Property>
<DTS:Property DTS:Name="ObjectName">CustomFileCopyTask</DTS:Property>
<DTS:Property DTS:Name="DTSID">{E4168410-1CEC-4CC2-975D-9349F44ABEDB}
</DTS:Property>
<DTS:Property DTS:Name="Description">CustomFileCopyTask</DTS:Property>
<DTS:Property DTS:Name="CreationName">
CustomFileCopyTask.CustomFileCopy, CustomFileCopyTask, Version=1.0.0.0, Culture=neutral,
PublicKeyToken=6d9410f0409e8e15
</DTS:Property>
<DTS:Property DTS:Name="DisableEventHandlers">0</DTS:Property>
<DTS:LoggingOptions>
  <DTS:Property DTS:Name="LoggingMode">0</DTS:Property>
  <DTS:Property DTS:Name="FilterKind">1</DTS:Property>
  <DTS:Property DTS:Name="EventFilter" DTS:DataType="8"></DTS:Property>
</DTS:LoggingOptions>
<DTS:ObjectData>
  <InnerObject>
    <DestFileName Type="8" Value="%TEMP%\t1.txt"/>
    <SourceFileName Type="8" Value="%TEMP%\SampleCurrencyData.txt"/>
  </InnerObject>
</DTS:ObjectData>
</DTS:Executable>
<DTS:Executable DTS:ExecutableType="SSIS.Pipeline.2">
  <DTS:Property DTS:Name="ExecutionLocation">0</DTS:Property>
  <DTS:Property DTS:Name="ExecutionAddress"></DTS:Property>
  <DTS:Property DTS:Name="TaskContact">
Performs high-performance data extraction, transformation and loading;Microsoft Corporation;
Microsoft SQL Server v9; (C) 2004 Microsoft Corporation; All Rights
Reserved;http://www.microsoft.com/sql/support/default.asp;1
  </DTS:Property>
  <DTS:Property DTS:Name="ForceExecValue">0</DTS:Property>
  <DTS:Property DTS:Name="ExecValue" DTS:DataType="3">0</DTS:Property>
  <DTS:Property DTS:Name="ForceExecutionResult">-1</DTS:Property>
  <DTS:Property DTS:Name="Disabled">0</DTS:Property>
  <DTS:Property DTS:Name="FailPackageOnFailure">0</DTS:Property>
  <DTS:Property DTS:Name="FailParentOnFailure">0</DTS:Property>
  <DTS:Property DTS:Name="MaxErrorCount">1</DTS:Property>
  <DTS:Property DTS:Name="ISOLevel">1048576</DTS:Property>
  <DTS:Property DTS:Name="LocaleID">-1</DTS:Property>
  <DTS:Property DTS:Name="TransactionOption">1</DTS:Property>
  <DTS:Property DTS:Name="DelayValidation">0</DTS:Property>
  <DTS:Property DTS:Name="ObjectName">Data Flow Task</DTS:Property>
  <DTS:Property DTS:Name="DTSID">{23B174F1-23C2-49F9-8512-03D5A2677E67}
</DTS:Property>
  <DTS:Property DTS:Name="Description">Data Flow Task</DTS:Property>
  <DTS:Property DTS:Name="CreationName">DTS.Pipeline.1</DTS:Property>
  <DTS:Property DTS:Name="DisableEventHandlers">0</DTS:Property>
  <DTS:LoggingOptions>
    <DTS:Property DTS:Name="LoggingMode">0</DTS:Property>
    <DTS:Property DTS:Name="FilterKind">1</DTS:Property>
    <DTS:Property DTS:Name="EventFilter" DTS:DataType="8"></DTS:Property>
  </DTS:LoggingOptions>
  <DTS:ObjectData>
    <pipeline id="0" name="pipelineXml" description="pipelineXml"
      defaultBufferMaxRows="10000" engineThreads="5" defaultBufferSize=
      "10485760" BLOBTempStoragePath="" bufferTempStoragePath=""
      runInOptimizedMode="true">
      <components>
        <component id="20" name="Flat File Source" componentClassID=
          "{5ACD952A-F16A-41D8-A681-713640837664}" description=
          "Flat File Source" localeId="1033" usesDispositions="true"
          validateExternalMetadata="True" version="1" pipelineVersion="0"
          contactInfo=
"Flat File Source;Microsoft Corporation;Microsoft SqlServer v9; (C) 2005 Microsoft
Corporation; All Rights Reserved; http://www.microsoft.com/sql/support;1">

```

```

<properties>
  <property id="26" name="RetainNulls" dataType=
    "System.Boolean" state="default" isArray="false"
    description="Specifies whether zero-length columns
    are treated as null." typeConverter="" UITypeEditor=""
    containsID="false" expressionType="None">>false</property>
  <property id="27" name="FileNameColumnName" dataType="System.String"
    state="default" isArray="false" description="Specifies the name of an output column
    containing the file name. If no name is specified, no output column containing the file name
    will be generated." typeConverter="" UITypeEditor="" containsID="false"
    expressionType="None"></property>
</properties>
<connections>
  <connection id="25" name="FlatFileConnection" description=""
    connectionManagerID="{00F5DC11-75D6-49FC-BE02-C4984643F39A}"/>
</connections>
<outputs>
  <output id="21" name="Flat File Source Output" description
    ="" exclusionGroup="0" synchronousInputId="0"
    deleteOutputOnPathDetached="false" hasSideEffects="false"
    dangling="false" isErrorOut="false" isSorted="false"
    errorOrTruncationOperation="" errorRowDisposition="NotUsed"
    truncationRowDisposition="NotUsed">
    <outputColumns>
      <outputColumn id="45" name="Column 0" description=""
        lineageId="45" precision="0" scale="0" length="0"
        dataType="r4" codePage="0" sortKeyPosition="0"
        comparisonFlags="0" specialFlags="0"
        errorOrTruncationOperation="Conversion"
        errorRowDisposition="FailComponent"
        truncationRowDisposition="FailComponent"
        externalMetadataColumnId="44">
        <properties>
          <property id="46" name="FastParse" dataType=
            "System.Boolean" state="default" isArray="false"
            description="Indicates whether the column uses the faster, locale-neutral parsing routines."
            typeConverter="" UITypeEditor="" containsID="false"
            expressionType="None">>false</property>
          <property id="47" name="UseBinaryFormat" dataType=
            "System.Boolean" state="default" isArray="false"
            description="Indicates whether the data is in binary format."
            typeConverter="" UITypeEditor="" containsID="false"
            expressionType="None">>false</property>
        </properties>
      </outputColumn>
      <outputColumn id="49" name="Column 1" description=""
        lineageId="49" precision="0" scale="0" length="3"
        dataType="str" codePage="1252" sortKeyPosition="0"
        comparisonFlags="0" specialFlags="0"
        errorOrTruncationOperation="Conversion"
        errorRowDisposition="FailComponent"
        truncationRowDisposition="FailComponent"
        externalMetadataColumnId="48">
        <properties>
          <property id="50" name="FastParse" dataType=
            "System.Boolean" state="default" isArray="false"
            description="Indicates whether the column uses the faster, locale-neutral parsing routines."
            typeConverter="" UITypeEditor="" containsID="false"
            expressionType="None">>false</property>
          <property id="51" name="UseBinaryFormat" dataType=
            "System.Boolean" state="default" isArray="false"
            description="Indicates whether the data is in binary format."
            typeConverter="" UITypeEditor="" containsID="false"
            expressionType="None">>false</property>
        </properties>
      </outputColumn>
      <outputColumn id="57" name="Column 3" description=""
        lineageId="57" precision="0" scale="0" length="0"
        dataType="r4" codePage="0" sortKeyPosition="0"

```

```

comparisonFlags="0" specialFlags="0"
errorOrTruncationOperation="Conversion"
errorRowDisposition="FailComponent"
truncationRowDisposition="FailComponent"
externalMetadataColumnId="56">
<properties>
  <property id="58" name="FastParse" dataType=
    "System.Boolean" state="default" isArray="false"
description="Indicates whether the column uses the faster, locale-neutral parsing routines."
    typeConverter="" UITypeEditor="" containsID="false"
    expressionType="None">false</property>
  <property id="59" name="UseBinaryFormat"
    dataType="System.Boolean" state="default" isArray=
    "false" description="Indicates whether the data is in binary format."
    typeConverter="" UITypeEditor="" containsID="false"
    expressionType="None">false</property>
</properties>
</outputColumn>
<outputColumn id="129" name="DateColumn" description=""
lineageId="129" precision="0" scale="0" length="0"
dataType="date" codePage="0" sortKeyPosition="0"
comparisonFlags="0" specialFlags="0"
errorOrTruncationOperation="Conversion"
errorRowDisposition="FailComponent"
truncationRowDisposition="FailComponent"
externalMetadataColumnId="128">
<properties>
  <property id="130" name="FastParse" dataType=
    "System.Boolean" state="default" isArray="false"
description="Indicates whether the column uses the faster, locale-neutral parsing routines."
    typeConverter="" UITypeEditor="" containsID="false"
    expressionType="None">false</property>
  <property id="131" name="UseBinaryFormat" dataType=
    "System.Boolean" state="default" isArray="false"
description="Indicates whether the data is in binary format."
    typeConverter="" UITypeEditor="" containsID="false"
    expressionType="None">false</property>
</properties>
</outputColumn>
</outputColumns>
<externalMetadataColumns isUsed="True">
  <externalMetadataColumn id="44" name="Column 0"
description="" precision="0" scale="0" length="0"
dataType="r4" codePage="0"/>
  <externalMetadataColumn id="48" name="Column 1"
description="" precision="0" scale="0" length="3"
dataType="str" codePage="1252"/>
  <externalMetadataColumn id="56" name="Column 3"
description="" precision="0" scale="0" length="0"
dataType="r4" codePage="0"/>
  <externalMetadataColumn id="128" name="DateColumn"
description="" precision="0" scale="0" length="0"
dataType="date" codePage="0"/>
</externalMetadataColumns>
</output>
<output id="22" name="Flat File Source Error Output"
description="" exclusionGroup="0" synchronousInputId="0"
deleteOutputOnPathDetached="false" hasSideEffects="false"
dangling="false" isErrorOut="true" isSorted="false"
errorOrTruncationOperation="" errorRowDisposition="NotUsed"
truncationRowDisposition="NotUsed">
<outputColumns>
  <outputColumn id="60" name=
    "Flat File Source Error Output Column"
description="Flat File Source Error Output Column"
lineageId="60" precision="0" scale="0" length="0"
dataType="text" codePage="1252" sortKeyPosition="0"
comparisonFlags="0" specialFlags="0"
errorOrTruncationOperation="" errorRowDisposition=

```

```

        "NotUsed" truncationRowDisposition="NotUsed"
        externalMetadataColumnId="0"/>
    <outputColumn id="23" name="ErrorColumn" description=""
        lineageId="23" precision="0" scale="0" length="0"
        dataType="i4" codePage="0" sortKeyPosition="0"
        comparisonFlags="0" specialFlags="1"
        errorOrTruncationOperation=""
        errorRowDisposition="NotUsed" truncationRowDisposition=
        "NotUsed" externalMetadataColumnId="0"/>
    <outputColumn id="24" name="ErrorColumn" description=""
        lineageId="24" precision="0" scale="0" length="0"
        dataType="i4" codePage="0" sortKeyPosition="0"
        comparisonFlags="0" specialFlags="2"
        errorOrTruncationOperation="" errorRowDisposition=
        "NotUsed" truncationRowDisposition="NotUsed"
        externalMetadataColumnId="0"/>
    </outputColumns>
    <externalMetadataColumns isUsed="False"/>
</output>
</outputs>
</component>
<component id="1" name="CalendarTransform"
    componentClassID="{BF01D463-7089-41EE-8F05-0A6DC17CE633}"
    description="Generates Roman, financial, reporting, manufacturing and IOS8601 calendar data."
    localeId="-1" usesDispositions="false"
    validateExternalMetadata="True" version="0"
    pipelineVersion="0" contactInfo="">
    <properties>
        <property id="5" name="First day of week"
            dataType="System.String" state="default"
            isArray="false" description="Start day of logical week"
            typeConverter="Microsoft.Samples.SqlServer.Dts.DataFlow.FirstDayOfWeekConverter,
            CalendarTransform, Version=1.0.0.0, Culture=neutral, PublicKeyToken=e9fac57941009407"
            UITypeEditor="" containsID="false"
            expressionType="None">Tuesday</property>
        <property id="6" name="Fiscal definition"
            dataType="System.String" state="default"
            isArray="false" description=
            "Parameter list defining fiscal calendar"
            typeConverter="" UITypeEditor="" containsID="false"
            expressionType="None">StartDay=1, StartMonth=1, YearDelta=0
        </property>
        <property id="7" name="Manufacturing definition"
            dataType="System.String" state="default" isArray="false"
            description="Parameter list defining manufacturing calendar"
            typeConverter="" UITypeEditor="" containsID="false"
            expressionType="None">StartMonth=1, StartWeek=1, Quarter=1
        </property>
        <property id="8" name="Reporting definition" dataType=
            "System.String" state="default" isArray="false"
            description="Parameter list defining reporting calendar"
            typeConverter="" UITypeEditor="" containsID="false"
            expressionType="None">StartMonth=1, StartWeek=1, Pattern=445
        </property>
        <property id="11" name="UserComponentTypeName"
            dataType="System.String" state="default" isArray="false"
            description="" typeConverter="" UITypeEditor=""
            containsID="false" expressionType="None">
            Microsoft.Samples.SqlServer.Dts.DataFlow.CalendarTransform, CalendarTransform,
            Version=1.0.0.0, Culture=neutral, PublicKeyToken=e9fac57941009407
        </property>
    </properties>
    <inputs>
        <input id="9" name="CalendarInput" description=
            "Synchronous input columns for component"
            hasSideEffects="false" dangling="false"
            errorOrTruncationOperation="" errorRowDisposition=
            "NotUsed" truncationRowDisposition="NotUsed">
        <inputColumns>

```

```

        <inputColumn id="165" name="DateColumn" description=""
            lineageId="129" usageType="readWrite"
            errorOrTruncationOperation=""
            errorRowDisposition="NotUsed"
            truncationRowDisposition="NotUsed"
            externalMetadataColumnId="0"/>
    </inputColumns>
    <externalMetadataColumns isUsed="False"/>
</input>
</inputs>
<outputs>
    <output id="10" name="CalendarOutput"
description="Synchronous output columns for component"
        exclusionGroup="0" synchronousInputId="9"
        deleteOutputOnPathDetached="false" hasSideEffects=
        "false" dangling="false" isErrorOut="false"
        isSorted="false" errorOrTruncationOperation=""
        errorRowDisposition="NotUsed"
        truncationRowDisposition="NotUsed">
    <outputColumns>
        <outputColumn id="166" name="Column" description=""
            lineageId="166" precision="0" scale="0"
            length="0" dataType="dbTimeStamp"
            codePage="0" sortKeyPosition="0"
            comparisonFlags="0" specialFlags="0"
            errorOrTruncationOperation=""
            errorRowDisposition="NotUsed"
            truncationRowDisposition="NotUsed"
            externalMetadataColumnId="0">
            <properties>
                <property id="167" name="Attribute Type" dataType=
                    "System.String" state="default" isArray=
                    "false" description="Time period attribute type"
                    typeConverter=
"Microsoft.Samples.SqlServer.Dts.DataFlow.TimeAttributeTypeConverter, CalendarTransform,
Version=1.0.0.0, Culture=neutral, PublicKeyToken=e9fac57941009407"
                    UITypeEditor="" containsID="false"
                    expressionType="None">Days</property>
                <property id="168" name="Attribute Part" dataType=
                    "System.String" state="default" isArray=
                    "false" description="Time period attribute part"
                    typeConverter=
"Microsoft.Samples.SqlServer.Dts.DataFlow.TimeAttributePartConverter, CalendarTransform,
Version=1.0.0.0, Culture=neutral, PublicKeyToken=e9fac57941009407"
                    UITypeEditor="" containsID="false"
                    expressionType="None">Key</property>
                <property id="169" name="Format" dataType=
                    "System.String" state="default"
                    isArray="false" description=
"Optional format string (output coerced to string)"
                    typeConverter="" UITypeEditor=""
                    containsID="false" expressionType="None">
            </property>
            </properties>
        </outputColumn>
    </outputColumns>
    <externalMetadataColumns isUsed="False"/>
</output>
</outputs>
</component>
<component id="170" name="Flat File Destination"
    componentClassID="{D658C424-8CF0-441C-B3C4-955E183B7FBA}"
    description="Flat File Destination" localeId="1033"
    usesDispositions="false" validateExternalMetadata="True"
    version="0" pipelineVersion="0" contactInfo=
"Flat File Destination;Microsoft Corporation;Microsoft SqlServer v9; (C) 2005 Microsoft
Corporation; All Rights Reserved; http://www.microsoft.com/sql/support;0">
    <properties>
        <property id="173" name="Overwrite" dataType="System.Boolean"

```



```

        state="default" isArray="false" description=
"Specifies whether the data will overwrite or append to the destination file."
        typeConverter="" UITypeEditor="" containsID="false"
        expressionType="None">true</property>
    <property id="174" name="Header" dataType="System.Null"
        state="default" isArray="false" description=
"Specifies the text to write to the destination file before any data is written."
        typeConverter="" UITypeEditor="" containsID="false"
        expressionType="Notify"/>
</properties>
<connections>
    <connection id="172" name="FlatFileConnection" description=""
connectionManagerID="{4F717107-732B-4C1B-AAF5-A5A31B6FECE8}"/>
</connections>
<inputs>
    <input id="171" name="Flat File Destination Input"
        description="" hasSideEffects="true" dangling="false"
        errorOrTruncationOperation="" errorRowDisposition=
        "NotUsed" truncationRowDisposition="NotUsed">
    <inputColumns>
        <inputColumn id="191" name="" description="" lineageId
        ="45" usageType="readOnly"
        errorOrTruncationOperation=""
        errorRowDisposition="NotUsed"
        truncationRowDisposition="NotUsed"
        externalMetadataColumnId="186"/>
        <inputColumn id="192" name="" description=""
        lineageId="49" usageType="readOnly"
        errorOrTruncationOperation=""
        errorRowDisposition="NotUsed"
        truncationRowDisposition="NotUsed"
        externalMetadataColumnId="187"/>
        <inputColumn id="193" name="" description=""
        lineageId="57" usageType="readOnly"
        errorOrTruncationOperation=""
        errorRowDisposition="NotUsed"
        truncationRowDisposition="NotUsed"
        externalMetadataColumnId="188"/>
        <inputColumn id="194" name="" description=""
        lineageId="129" usageType="readOnly"
        errorOrTruncationOperation=""
        errorRowDisposition="NotUsed"
        truncationRowDisposition="NotUsed"
        externalMetadataColumnId="189"/>
        <inputColumn id="195" name="" description=""
        lineageId="166" usageType="readOnly"
        errorOrTruncationOperation=""
        errorRowDisposition="NotUsed"
        truncationRowDisposition="NotUsed"
        externalMetadataColumnId="190"/>
    </inputColumns>
    <externalMetadataColumns isUsed="True">
        <externalMetadataColumn id="186" name="Column 0"
        description="" precision="0" scale="0"
        length="0" dataType="r4" codePage="0"/>
        <externalMetadataColumn id="187" name="Column 1"
        description="" precision="0" scale="0"
        length="3" dataType="str" codePage="1252"/>
        <externalMetadataColumn id="188" name="Column 3"
        description="" precision="0" scale="0"
        length="0" dataType="r4" codePage="0"/>
        <externalMetadataColumn id="189" name="DateColumn"
        description="" precision="0" scale="0"
        length="0" dataType="date" codePage="0"/>
        <externalMetadataColumn id="190" name="Column"
        description="" precision="0" scale="0"
        length="0" dataType="dbTimeStamp"
        codePage="0"/>
    </externalMetadataColumns>

```

```

        </input>
    </inputs>
</component>
</components>
<paths>
    <path id="61" name="Flat File Source Output"
        description="" startId="21" endId="9"/>
    <path id="180" name="CalendarOutput"
        description="" startId="10" endId="171"/>
</paths>
</pipeline>
</DTS:ObjectData>
</DTS:Executable>
<DTS:Executable DTS:ExecutableType=
"Microsoft.SqlServer.Dts.Tasks.FileSystemTask.FileSystemTask,
Microsoft.SqlServer.FileSystemTask, Version=10.0.0.0, Culture=neutral,
PublicKeyToken=89845dcd8080cc91"
    DTS:ThreadHint="0">
    <DTS:Property DTS:Name="ExecutionLocation">0</DTS:Property>
    <DTS:Property DTS:Name="ExecutionAddress"></DTS:Property>
    <DTS:Property DTS:Name="TaskContact">
File System Task;Microsoft Corporation; Microsoft SQL Server v9; © 2004 Microsoft
Corporation; All Rights
Reserved;http://www.microsoft.com/sql/support/default.asp;1</DTS:Property>
    <DTS:Property DTS:Name="ForceExecValue">0</DTS:Property>
    <DTS:Property DTS:Name="ExecValue" DTS:DataType="3">0</DTS:Property>
    <DTS:Property DTS:Name="ForceExecutionResult">-1</DTS:Property>
    <DTS:Property DTS:Name="Disabled">0</DTS:Property>
    <DTS:Property DTS:Name="FailPackageOnFailure">0</DTS:Property>
    <DTS:Property DTS:Name="FailParentOnFailure">0</DTS:Property>
    <DTS:Property DTS:Name="MaxErrorCount">1</DTS:Property>
    <DTS:Property DTS:Name="ISOLevel">1048576</DTS:Property>
    <DTS:Property DTS:Name="LocaleID">-1</DTS:Property>
    <DTS:Property DTS:Name="TransactionOption">1</DTS:Property>
    <DTS:Property DTS:Name="DelayValidation">0</DTS:Property>
    <DTS:Property DTS:Name="ObjectName">File Delete Task</DTS:Property>
    <DTS:Property DTS:Name="DTSID">{36115195-BDBC-4265-977F-5579CB1542CE}
</DTS:Property>
    <DTS:Property DTS:Name="Description">File System Task</DTS:Property>
    <DTS:Property DTS:Name="CreationName">
Microsoft.SqlServer.Dts.Tasks.FileSystemTask.FileSystemTask,
Microsoft.SqlServer.FileSystemTask, Version=9.0.242.0, Culture=neutral,
PublicKeyToken=89845dcd8080cc91
</DTS:Property>
    <DTS:Property DTS:Name="DisableEventHandlers">0</DTS:Property>
    <DTS:LoggingOptions>
    <DTS:Property DTS:Name="LoggingMode">0</DTS:Property>
    <DTS:Property DTS:Name="FilterKind">1</DTS:Property>
    <DTS:Property DTS:Name="EventFilter" DTS:DataType="8"></DTS:Property>
</DTS:LoggingOptions>
    <DTS:ObjectData>
    <FileSystemData TaskOperationType="DeleteFile" OperationName=""
        TaskOverwriteDestFile="False"
        TaskSourcePath="{00F5DC11-75D6-49FC-BE02-C4984643F39A}"
        TaskIsSourceVariable="False" TaskDestinationPath=""
        TaskIsDestinationVariable="False" TaskFileAttributes="Normal"/>
    </DTS:ObjectData>
</DTS:Executable>
<DTS:PrecedenceConstraint>
    <DTS:Property DTS:Name="Value">0</DTS:Property>
    <DTS:Property DTS:Name="EvalOp">2</DTS:Property>
    <DTS:Property DTS:Name="LogicalAnd">-1</DTS:Property>
    <DTS:Property DTS:Name="Expression"></DTS:Property>
    <DTS:Property DTS:Name="ObjectName">Constraint</DTS:Property>
    <DTS:Property DTS:Name="DTSID">
{ECFD7682-860A-4F39-BF2A-37C0C23C8D39}</DTS:Property>
    <DTS:Property DTS:Name="Description"></DTS:Property>
    <DTS:Property DTS:Name="CreationName"></DTS:Property>
    <DTS:Executable IDREF="{E4168410-1CEC-4CC2-975D-9349F44ABEDB}"

```

```

        DTS:IsFrom="-1"/>
    <DTS:Executable IDREF="{23B174F1-23C2-49F9-8512-03D5A2677E67}"
        DTS:IsFrom="0"/>
</DTS:PrecedenceConstraint>
<DTS:PrecedenceConstraint>
    <DTS:Property DTS:Name="Value">0</DTS:Property>
    <DTS:Property DTS:Name="EvalOp">2</DTS:Property>
    <DTS:Property DTS:Name="LogicalAnd">-1</DTS:Property>
    <DTS:Property DTS:Name="Expression"></DTS:Property>
    <DTS:Property DTS:Name="ObjectName">Constraint 1</DTS:Property>
    <DTS:Property DTS:Name="DTSID">{380B124F-4D04-42F1-A9D5-2BA4AF584DB2}
</DTS:Property>
    <DTS:Property DTS:Name="Description"></DTS:Property>
    <DTS:Property DTS:Name="CreationName"></DTS:Property>
    <DTS:Executable IDREF="{23B174F1-23C2-49F9-8512-03D5A2677E67}"
        DTS:IsFrom="-1"/>
    <DTS:Executable IDREF="{36115195-BDBC-4265-977F-5579CB1542CE}"
        DTS:IsFrom="0"/>
</DTS:PrecedenceConstraint>
<DTS:PackageVariable>
    <DTS:Property DTS:Name="PackageVariableValue" DTS:DataType="8">
        &lt;TaskHost xmlns:xsd="http://www.w3.org/2001/XMLSchema"
xmlns:xsi="http://www.w3.org/2001/XMLSchema-instance"
xmlns:ddl2="http://schemas.microsoft.com/analysisisservices/2003/engine/2"
xmlns:ddl2_2="http://schemas.microsoft.com/analysisisservices/2003/engine/2/2"
xmlns:dwd="http://schemas.microsoft.com/DataWarehouse/Designer/1.0"&gt;&lt;dwd:DtsDataFlowDiagram&gt;&lt;dwd:BoundingTop&gt;1000&lt;/dwd:BoundingTop&gt;&lt;dwd:Layout&gt;&lt;dds&gt;
        &lt;diagram fontclsid="{0BE35203-8F91-11CE-9DE3-00AA004BB851}"
mouseiconclsid="{0BE35204-8F91-11CE-9DE3-00AA004BB851}"
defaultlayout="Microsoft.DataWarehouse.Layout.GraphLayout"
defaultlineroute="Microsoft.DataWarehouse.Layout.GraphLayout" version="7" nextobject="15"
scale="100" pagebreakanchorx="0" pagebreakanchory="0" pagebreaksizex="0" pagebreaksizey="0"
scrollleft="-1000" scrolltop="0" gridx="150" gridy="150" marginx="1000" marginy="1000"
zoom="100" x="34131" y="18600" bgcolor="15334399" defaultpersistence="2"
PrintPageNumbersMode="3" PrintMarginTop="0" PrintMarginBottom="635" PrintMarginLeft="0"
PrintMarginRight="0" marqueeeselectionmode="1" mousepointer="0" snaptogrid="0"
autotypeannotation="1" showscrollbars="0" viewpagebreaks="0"
donotforceconnectorsbehindshapes="0" backpictureclsid="{00000000-0000-0000-0000-000000000000}"&gt;
        &lt;font&gt;
        &lt;ddsxmlobjectstreamwrapper binary="01010000900180380100065461686f6d61" /&gt;
        &lt;/font&gt;
        &lt;mouseicon&gt;
        &lt;ddsxmlobjectstreamwrapper binary="6c74000000000000" /&gt;
        &lt;/mouseicon&gt;
        &lt;/diagram&gt;
        &lt;layoutmanager&gt;
        &lt;ddsxmlobj /&gt;
        &lt;/layoutmanager&gt;
        &lt;ddscontrol controlprogid="DdsShapes.DdsObjectManagedBridge.1" tooltip="Generates
Roman, financial, reporting, manufacturing and IOS8601 calendar data." left="1587" top="9260"
logicalid="6" controlid="1" masterid="0" hint1="0" hint2="0" width="3704" height="1164"
noresize="0" nomove="0" nodefaultattachpoints="0" autodrag="1" usedefaultiddshape="1"
selectable="1" showselectionhandles="1" allownudging="1" isannotation="0" dontautolayout="0"
groupcollapsed="0" tabstop="1" visible="1" snaptogrid="0"&gt;
        &lt;control&gt;
        &lt;ddsxmlobjectstreaminitwrapper binary="00080000780e00008c040000" /&gt;
        &lt;/control&gt;
        &lt;layoutobject&gt;
        &lt;ddsxmlobj&gt;
        &lt;property name="LogicalObject" value="{23B174F1-23C2-49F9-8512-
03D5A2677E67}/components/1" vartype="8" /&gt;
        &lt;property name="ShowConnectorSource" value="0" vartype="2" /&gt;
        &lt;/ddsxmlobj&gt;
        &lt;/layoutobject&gt;
        &lt;shape groupshapeid="0" groupnode="0" /&gt;
        &lt;/ddscontrol&gt;
        &lt;ddscontrol controlprogid="DdsShapes.DdsObjectManagedBridge.1" tooltip="Flat File
Source" left="0" top="2328" logicalid="7" controlid="2" masterid="0" hint1="0" hint2="0"

```

```

width="3598" height="1164" noresize="0" nomove="0" nodefaultattachpoints="0" autodrag="1"
usedefaultiddshape="1" selectable="1" showselectionhandles="1" allownudging="1"
isannotation="0" dontautolayout="0" groupcollapsed="0" tabstop="1" visible="1"
snaptogrid="0"&gt;
  &lt;control&gt;
    &lt;ddsxmlobjectstreaminitwrapper binary="000800000e0e00008c040000" /&gt;
  &lt;/control&gt;
  &lt;layoutobject&gt;
    &lt;ddsxmlobj&gt;
      &lt;property name="LogicalObject" value="{23B174F1-23C2-49F9-8512-
03D5A2677E67}/components/20" vartype="8" /&gt;
      &lt;property name="ShowConnectorSource" value="0" vartype="2" /&gt;
    &lt;/ddsxmlobj&gt;
  &lt;/layoutobject&gt;
  &lt;shape groupshapeid="0" groupnode="0" /&gt;
  &lt;/ddscontrol&gt;
  &lt;ddscontrol controlprogid="MSDDS.Polyline" left="1400" top="3093" logicalid="8"
controlid="3" masterid="0" hint1="0" hint2="0" width="2439" height="6667" noresize="0"
nomove="0" nodefaultattachpoints="1" autodrag="0" usedefaultiddshape="0" selectable="1"
showselectionhandles="0" allownudging="1" isannotation="0" dontautolayout="0"
groupcollapsed="0" tabstop="1" visible="1" snaptogrid="0"&gt;
    &lt;control&gt;
      &lt;ddsxmlobj&gt;
        &lt;polyline endtypedst="3" endtypesrc="1" usercolor="32768" linestyle="0"
linerender="1" customendtypedstid="0" customendtypesrcid="0" adornsvisible="1" /&gt;
      &lt;/ddsxmlobj&gt;
    &lt;/control&gt;
  &lt;/layoutobject&gt;
  &lt;ddsxmlobj&gt;
    &lt;property name="LogicalObject" value="{23B174F1-23C2-49F9-8512-
03D5A2677E67}/paths/61" vartype="8" /&gt;
    &lt;property name="Virtual" value="0" vartype="11" /&gt;
    &lt;property name="VisibleAP" value="0" vartype="3" /&gt;
  &lt;/ddsxmlobj&gt;
  &lt;/layoutobject&gt;
  &lt;connector lineroutestyle="Microsoft.DataWarehouse.Layout.GraphLayout" sourceid="2"
destid="1" sourceattachpoint="7" destattachpoint="6" segmenteditmode="0"
bendpointeditmode="0" bendpointvisibility="2" relatedid="0" virtual="0"&gt;
    &lt;point x="1799" y="3492" /&gt;
    &lt;point x="1799" y="6376" /&gt;
    &lt;point x="3439" y="6376" /&gt;
    &lt;point x="3439" y="9260" /&gt;
  &lt;/connector&gt;
  &lt;/ddscontrol&gt;
  &lt;ddscontrol controlprogid="DdsShapes.DdsObjectManagedBridge.1" tooltip="Flat File
Destination" left="4366" top="13944" logicalid="9" controlid="4" masterid="0" hint1="0"
hint2="0" width="3598" height="1164" noresize="0" nomove="0" nodefaultattachpoints="0"
autodrag="1" usedefaultiddshape="1" selectable="1" showselectionhandles="1" allownudging="1"
isannotation="0" dontautolayout="0" groupcollapsed="0" tabstop="1" visible="1"
snaptogrid="0"&gt;
    &lt;control&gt;
      &lt;ddsxmlobjectstreaminitwrapper binary="000800000e0e00008c040000" /&gt;
    &lt;/control&gt;
    &lt;layoutobject&gt;
      &lt;ddsxmlobj&gt;
        &lt;property name="LogicalObject" value="{23B174F1-23C2-49F9-8512-
03D5A2677E67}/components/170" vartype="8" /&gt;
        &lt;property name="ShowConnectorSource" value="0" vartype="2" /&gt;
      &lt;/ddsxmlobj&gt;
    &lt;/layoutobject&gt;
    &lt;shape groupshapeid="0" groupnode="0" /&gt;
    &lt;/ddscontrol&gt;
    &lt;ddscontrol controlprogid="MSDDS.Polyline" left="3040" top="10025" logicalid="10"
controlid="5" masterid="0" hint1="0" hint2="0" width="3525" height="4419" noresize="0"
nomove="0" nodefaultattachpoints="1" autodrag="0" usedefaultiddshape="0" selectable="1"
showselectionhandles="0" allownudging="1" isannotation="0" dontautolayout="0"
groupcollapsed="0" tabstop="1" visible="1" snaptogrid="0"&gt;
      &lt;control&gt;
        &lt;ddsxmlobj&gt;

```

```

        <polyline endtypedst="3" endtypesrc="1" usercolor="32768" linestyle="0"
linerender="1" customendtypedstid="0" customendtypesrcid="0" adornsvisible="1" />
        </ddsxmlobj>
        </control>
        </layoutobject>
        </ddsxmlobj>
        <property name="LogicalObject" value="{23B174F1-23C2-49F9-8512-
03D5A2677E67}/paths/180" vartype="8" />
        <property name="Virtual" value="0" vartype="11" />
        <property name="VisibleAP" value="0" vartype="3" />
        </ddsxmlobj>
        </layoutobject>
        <connector lineroutestyle="Microsoft.DataWarehouse.Layout.GraphLayout" sourceid="1"
destid="4" sourceattachpoint="7" destattachpoint="6" segmenteditmode="0"
bendpointeditmode="0" bendpointvisibility="2" relatedid="0" virtual="0">
        <point x="3439" y="10424" />
        <point x="3439" y="12184" />
        <point x="6165" y="12184" />
        <point x="6165" y="13944" />
        </connector>
        </ddscontrol>
        </dds>
        </dwd:Layout>
        </dwd:PersistedViewPortLeft>
1000</dwd:PersistedViewPortLeft>
</DTS:Property>
<DTS:Property DTS:Name="Namespace">dts-designer-1.0</DTS:Property>
<DTS:Property DTS:Name="ObjectName">
{23B174F1-23C2-49F9-8512-03D5A2677E67}</DTS:Property>
<DTS:Property DTS:Name="DTSID">
{4E58A203-3C53-415B-AC2D-8E70958FDA9C}</DTS:Property>
<DTS:Property DTS:Name="Description"></DTS:Property>
<DTS:Property DTS:Name="CreationName"></DTS:Property>
</DTS:PackageVariable>
<DTS:PackageVariable>
<DTS:Property DTS:Name="PackageVariableValue" DTS:DataType="8">
<PipelinePath xmlns:xsd="http://www.w3.org/2001/XMLSchema"
xmlns:xsi="http://www.w3.org/2001/XMLSchema-instance"
xmlns:ddl2="http://schemas.microsoft.com/analysisisservices/2003/engine/2"
xmlns:ddl2_2="http://schemas.microsoft.com/analysisisservices/2003/engine/2/2"
xmlns:dwd="http://schemas.microsoft.com/DataWarehouse/Designer/1.0">
<dwd:DestinationName>Flat File Destination
Input</dwd:DestinationName>
<dwd:SourceName>CalendarOutput</dwd:SourceName>
</PipelinePath>
</DTS:Property>
<DTS:Property DTS:Name="Namespace">dts-designer-1.0</DTS:Property>
<DTS:Property DTS:Name="ObjectName">{23B174F1-23C2-49F9-8512-03D5A2677E67}-
180</DTS:Property>
<DTS:Property DTS:Name="DTSID">{39EC5E29-C552-4771-A608-54CD23A218E8}</DTS:Property>
<DTS:Property DTS:Name="Description"></DTS:Property>
<DTS:Property DTS:Name="CreationName"></DTS:Property>
</DTS:PackageVariable>
<DTS:PackageVariable>
<DTS:Property DTS:Name="PackageVariableValue" DTS:DataType="8">
<PipelinePath xmlns:xsd="http://www.w3.org/2001/XMLSchema"
xmlns:xsi="http://www.w3.org/2001/XMLSchema-instance"
xmlns:ddl2="http://schemas.microsoft.com/analysisisservices/2003/engine/2"
xmlns:ddl2_2="http://schemas.microsoft.com/analysisisservices/2003/engine/2/2"
xmlns:dwd="http://schemas.microsoft.com/DataWarehouse/Designer/1.0">
<dwd:DestinationName>CalendarInput</dwd:DestinationName>
<dwd:SourceName>Flat File Source
Output</dwd:SourceName>
</PipelinePath>
</DTS:Property>
<DTS:Property DTS:Name="Namespace">dts-designer-1.0</DTS:Property>
<DTS:Property DTS:Name="ObjectName">
{23B174F1-23C2-49F9-8512-03D5A2677E67}-61</DTS:Property>
<DTS:Property DTS:Name="DTSID">
{2C2FBCB9-7EC6-4D0A-A352-0323E0EBE5E6}</DTS:Property>
<DTS:Property DTS:Name="Description"></DTS:Property>
<DTS:Property DTS:Name="CreationName"></DTS:Property>
</DTS:PackageVariable>

```

```

<DTS:PackageVariable>
  <DTS:Property DTS:Name="PackageVariableValue" DTS:DataType="8">
    &lt;PrecedenceConstraint xmlns:xsd="http://www.w3.org/2001/XMLSchema"
xmlns:xsi="http://www.w3.org/2001/XMLSchema-instance"
xmlns:ddl2="http://schemas.microsoft.com/analysisisservices/2003/engine/2"
xmlns:ddl2_2="http://schemas.microsoft.com/analysisisservices/2003/engine/2/2"
xmlns:dwd="http://schemas.microsoft.com/DataWarehouse/Designer/1.0"&gt;&lt;dwd:EvalOp&gt;Cons
traint&lt;/dwd:EvalOp&gt;&lt;/PrecedenceConstraint&gt;
  </DTS:Property>
  <DTS:Property DTS:Name="Namespace">dts-designer-1.0</DTS:Property>
  <DTS:Property DTS:Name="ObjectName">
    {380B124F-4D04-42F1-A9D5-2BA4AF584DB2}</DTS:Property>
  <DTS:Property DTS:Name="DTSID">
    {70E7F0E0-0650-48D3-AD12-02695CEFE9B4}</DTS:Property>
  <DTS:Property DTS:Name="Description"></DTS:Property>
  <DTS:Property DTS:Name="CreationName"></DTS:Property>
</DTS:PackageVariable>
<DTS:PackageVariable>
  <DTS:Property DTS:Name="PackageVariableValue" DTS:DataType="8">
    &lt;Package xmlns:xsd="http://www.w3.org/2001/XMLSchema"
xmlns:xsi="http://www.w3.org/2001/XMLSchema-instance"
xmlns:ddl2="http://schemas.microsoft.com/analysisisservices/2003/engine/2"
xmlns:ddl2_2="http://schemas.microsoft.com/analysisisservices/2003/engine/2/2"
xmlns:dwd="http://schemas.microsoft.com/DataWarehouse/Designer/1.0"&gt;&lt;dwd:DtsControlFlow
Diagram&gt;&lt;dwd:BoundingLeft&gt;1000&lt;/dwd:BoundingLeft&gt;&lt;dwd:BoundingTop&gt;1000&lt;
t;/dwd:BoundingTop&gt;&lt;dwd:Layout&gt;&lt;dds&gt;
  &lt;diagram fontclsid="{0BE35203-8F91-11CE-9DE3-00AA004BB851}"
mouseiconclsid="{0BE35204-8F91-11CE-9DE3-00AA004BB851}"
defaultlayout="Microsoft.DataWarehouse.Layout.GraphLayout"
defaultlineroute="Microsoft.DataWarehouse.Layout.GraphLayout" version="7" nextobject="11"
scale="100" pagebreakanchorx="0" pagebreakanchory="0" pagebreaksize="0" pagebreaksizey="0"
scrollleft="0" scrolltop="0" gridx="150" gridy="150" marginx="1000" marginy="1000" zoom="100"
x="34131" y="19526" backcolor="15334399" defaultpersistence="2" PrintPageNumbersMode="3"
PrintMarginTop="0" PrintMarginBottom="635" PrintMarginLeft="0" PrintMarginRight="0"
marqueeselectionmode="1" mousepointer="0" snaptogrid="0" autotypeannotation="1"
showscrollbars="0" viewpagebreaks="0" donotforceconnectorsbehindshapes="1"
backpictureclsid="{00000000-0000-0000-0000-000000000000}"&gt;
  &lt;font&gt;
  &lt;ddsxmlobjectstreamwrapper binary="01010000900180380100065461686f6d61" /&gt;
  &lt;/font&gt;
  &lt;mouseicon&gt;
  &lt;ddsxmlobjectstreamwrapper binary="6c74000000000000" /&gt;
  &lt;/mouseicon&gt;
  &lt;/diagram&gt;
  &lt;layoutmanager&gt;
  &lt;ddsxmlobj /&gt;
  &lt;/layoutmanager&gt;
  &lt;ddscontrol controlprogid="DdsShapes.DdsObjectManagedBridge.1" tooltip="Data Flow
Task" left="3677" top="4095" logicalid="2" controlid="1" masterid="0" hint1="0" hint2="0"
width="3598" height="1164" noresize="0" nomove="0" nodefaultattachpoints="0" autodrag="1"
usedefaulttiddshape="1" selectable="1" showselectionhandles="1" allownudging="1"
isannotation="0" dontautolayout="0" groupcollapsed="0" tabstop="1" visible="1"
snaptogrid="0"&gt;
  &lt;control&gt;
  &lt;ddsxmlobjectstreaminitwrapper binary="000800000e0e00008c040000" /&gt;
  &lt;/control&gt;
  &lt;layoutobject&gt;
  &lt;ddsxmlobj&gt;
  &lt;property name="LogicalObject" value="{23B174F1-23C2-49F9-8512-03D5A2677E67}"
vartype="8" /&gt;
  &lt;property name="ShowConnectorSource" value="0" vartype="2" /&gt;
  &lt;/ddsxmlobj&gt;
  &lt;/layoutobject&gt;
  &lt;shape groupshapeid="0" groupnode="0" /&gt;
  &lt;/ddscontrol&gt;
  &lt;ddscontrol controlprogid="DdsShapes.DdsObjectManagedBridge.1"
tooltip="CustomFileCopyTask" left="3386" top="1032" logicalid="5" controlid="4" masterid="0"
hint1="0" hint2="0" width="3598" height="1164" noresize="0" nomove="0"
nodefaultattachpoints="0" autodrag="1" usedefaulttiddshape="1" selectable="1"

```

```

showselectionhandles="1" allownudging="1" isannotation="0" dontautolayout="0"
groupcollapsed="0" tabstop="1" visible="1" snaptogrid="0"&gt;
  &lt;&control&gt;
  &lt;&ddsxmlobjectstreaminitwrapper binary="000800000e0e00008c040000" /&gt;
  &lt;/control&gt;
  &lt;&layoutobject&gt;
  &lt;&ddsxmlobj&gt;
  &lt;&property name="LogicalObject" value="{E4168410-1CEC-4CC2-975D-9349F44ABEDB}"
vartype="8" /&gt;
  &lt;&property name="ShowConnectorSource" value="0" vartype="2" /&gt;
  &lt;/ddsxmlobj&gt;
  &lt;/layoutobject&gt;
  &lt;&shape groupshapeid="0" groupnode="0" /&gt;
  &lt;&ddscontrol&gt;
  &lt;&ddscontrol controlprogid="DdsShapes.DdsObjectManagedBridge.1" tooltip="File System
Task" left="3678" top="8334" logicalid="7" controlid="6" masterid="0" hint1="0" hint2="0"
width="3598" height="1164" noresize="0" nomove="0" nodefaultattachpoints="0" autodrag="1"
usedefaultiddshape="1" selectable="1" showselectionhandles="1" allownudging="1"
isannotation="0" dontautolayout="0" groupcollapsed="0" tabstop="1" visible="1"
snaptogrid="0"&gt;
  &lt;&control&gt;
  &lt;&ddsxmlobjectstreaminitwrapper binary="000800000e0e00008c040000" /&gt;
  &lt;/control&gt;
  &lt;&layoutobject&gt;
  &lt;&ddsxmlobj&gt;
  &lt;&property name="LogicalObject" value="{36115195-BDBC-4265-977F-5579CB1542CE}"
vartype="8" /&gt;
  &lt;&property name="ShowConnectorSource" value="0" vartype="2" /&gt;
  &lt;/ddsxmlobj&gt;
  &lt;/layoutobject&gt;
  &lt;&shape groupshapeid="0" groupnode="0" /&gt;
  &lt;&ddscontrol&gt;
  &lt;&ddscontrol controlprogid="MSDDS.Polyline" left="4786" top="1797" logicalid="9"
controlid="8" masterid="0" hint1="0" hint2="0" width="1090" height="2798" noresize="0"
nomove="0" nodefaultattachpoints="1" autodrag="0" usedefaultiddshape="0" selectable="1"
showselectionhandles="0" allownudging="1" isannotation="0" dontautolayout="0"
groupcollapsed="0" tabstop="1" visible="1" snaptogrid="0"&gt;
  &lt;&control&gt;
  &lt;&ddsxmlobj&gt;
  &lt;&polyline endtypedst="3" endtypesrc="1" usercolor="32768" linestyle="0"
linerender="2" customendtypedstid="0" customendtypesrcid="0" adornsvisible="1" /&gt;
  &lt;/ddsxmlobj&gt;
  &lt;/control&gt;
  &lt;&layoutobject&gt;
  &lt;&ddsxmlobj&gt;
  &lt;&property name="LogicalObject" value="{ECFD7682-860A-4F39-BF2A-37C0C23C8D39}"
vartype="8" /&gt;
  &lt;&property name="Virtual" value="0" vartype="11" /&gt;
  &lt;&property name="VisibleAP" value="0" vartype="3" /&gt;
  &lt;/ddsxmlobj&gt;
  &lt;/layoutobject&gt;
  &lt;&connector lineroutestyle="Microsoft.DataWarehouse.Layout.GraphLayout" sourceid="4"
destid="1" sourceattachpoint="7" destattachpoint="6" segmenteditmode="0"
bendpointeditmode="0" endpointvisibility="2" relatedid="0" virtual="0"&gt;
  &lt;&point x="5185" y="2196" /&gt;
  &lt;&point x="5185" y="3145" /&gt;
  &lt;&point x="5476" y="3145" /&gt;
  &lt;&point x="5476" y="4095" /&gt;
  &lt;/connector&gt;
  &lt;&ddscontrol&gt;
  &lt;&ddscontrol controlprogid="MSDDS.Polyline" left="5077" top="4860" logicalid="10"
controlid="9" masterid="0" hint1="0" hint2="0" width="800" height="3974" noresize="0"
nomove="0" nodefaultattachpoints="1" autodrag="0" usedefaultiddshape="0" selectable="1"
showselectionhandles="0" allownudging="1" isannotation="0" dontautolayout="0"
groupcollapsed="0" tabstop="1" visible="1" snaptogrid="0"&gt;
  &lt;&control&gt;
  &lt;&ddsxmlobj&gt;
  &lt;&polyline endtypedst="3" endtypesrc="1" usercolor="32768" linestyle="0"
linerender="2" customendtypedstid="0" customendtypesrcid="0" adornsvisible="1" /&gt;
  &lt;/ddsxmlobj&gt;

```

```

        </control>
        </layoutobject>
        </ddsxmlobj>
        <property name="LogicalObject" value="{380B124F-4D04-42F1-A9D5-2BA4AF584DB2}"
vartype="8" />
        <property name="Virtual" value="0" vartype="11" />
        <property name="VisibleAP" value="0" vartype="3" />
        </ddsxmlobj>
        </layoutobject>
        <connector lineroutestyle="Microsoft.DataWarehouse.Layout.GraphLayout" sourceid="1"
destid="6" sourceattachpoint="7" destattachpoint="6" segmenteditmode="0"
bendpointeditmode="0" bendpointvisibility="2" relatedid="0" virtual="0">
        <point x="5476" y="5259" />
        <point x="5476" y="6796" />
        <point x="5477" y="6796" />
        <point x="5477" y="8334" />
        </connector>
        </ddscontrol>
        </dds>
        </dwd:Layout>
        </dwd:DtsControlFlowDiagram>
        </Package>
    </DTS:Property>
    <DTS:Property DTS:Name="Namespace">dts-designer-1.0</DTS:Property>
    <DTS:Property DTS:Name="ObjectName">
        {61EDFABA-B54F-4EFE-9FF2-DABDD94B9D51}</DTS:Property>
    <DTS:Property DTS:Name="DTSID">
        {05D4BDFA-476A-4364-AF28-B7E789B5B5C4}</DTS:Property>
    <DTS:Property DTS:Name="Description"></DTS:Property>
    <DTS:Property DTS:Name="CreationName"></DTS:Property>
    </DTS:PackageVariable>
    <DTS:PackageVariable>
        <DTS:Property DTS:Name="PackageVariableValue" DTS:DataType="8">
            <PrecedenceConstraint xmlns:xsd="http://www.w3.org/2001/XMLSchema"
xmlns:xsi="http://www.w3.org/2001/XMLSchema-instance"
xmlns:ddl2="http://schemas.microsoft.com/analysisservices/2003/engine/2"
xmlns:ddl2_2="http://schemas.microsoft.com/analysisservices/2003/engine/2/2"
xmlns:dwd="http://schemas.microsoft.com/DataWarehouse/Designer/1.0">
                <dwd:EvalOp>
                    <Constraint>
                        </DTS:Property>
                    <DTS:Property DTS:Name="Namespace">dts-designer-1.0</DTS:Property>
                    <DTS:Property DTS:Name="ObjectName">
                        {ECFD7682-860A-4F39-BF2A-37C0C23C8D39}</DTS:Property>
                    <DTS:Property DTS:Name="DTSID">
                        {0F16D98D-E992-4013-AFB9-179B19A88AAE}</DTS:Property>
                    <DTS:Property DTS:Name="Description"></DTS:Property>
                    <DTS:Property DTS:Name="CreationName"></DTS:Property>
                </DTS:PackageVariable>
            </DTS:Executable>
        </DTS:Property>
    </DTS:PackageVariable>
    </DTS:Executable>

```

4 Security

4.1 Security Considerations for Implementers

DTSX is a clear-text XML format. Therefore, all information that is persisted into the DTSX structure can be read by any person who has access to the file or who gains access to the file, even if such access was not intended. The security of the information can be increased by various methods, including the following:

- Restrict access to the file through use of access control lists (ACLs) or other methods.
- Set the **ProtectionLevel** property to a level that encrypts or hides sensitive information that is contained in the package file. For more information, see [ExecutableTypePackagePropertyNameEnum](#).
- Set the value for the **ProtectionLevel** property to "0". This causes sensitive information to be excluded from package file storage.
- Set the value for the **ProtectionLevel** property to "1" or "4". This causes sensitive information to be encrypted with a user key. For more information, see [Encryption with User Key](#).
- Set the values for the **ProtectionLevel** property to "2" or "3". This causes sensitive information to be encrypted with a password. For more information, see [Encryption with Password](#).
- Omit or encrypt specific element information, such as connection strings and passwords, from any file that is in DTSX format before it is persisted. At run time, a user interface can prompt for a password to access encrypted information or can prompt for the entry of omitted information that was not persisted in the file.

4.1.1 Encryption Implementation for Settings in the ProtectionLevel Property

Depending on the value selected for the **ProtectionLevel** property, one of two encryption algorithms is used: encryption with a user key or encryption with a password.

4.1.1.1 Encryption with User Key

If the **ProtectionLevel** property is set to the value "1" or "4", information is encrypted with a user key. The encryption is implemented by a call to the **CryptProtectData** function [[MSDN-CryptProtectData](#)]. The **CryptProtectData** function operates by including a key within the storage binary large object (BLOB) that opens and decrypts the persisted data only for a user who has the same credentials that were used to store the encrypted data.

4.1.1.2 Encryption with Password

If the **ProtectionLevel** property is set to the value "2" or "3", information is encrypted with a password. When information is encrypted with a password, the encryption algorithm that is used is the XML Encryption standard [[XMLEncSynProc](#)].

4.2 Index of Security Fields

| Security field | Section |
|---------------------------------|---|
| ProtectionLevel property | ExecutableTypePackagePropertyNameEnum |
| PackagePassword property | ExecutePackageTaskObjectDataType |
| PasswordElementType type | PasswordElementType |

| Security field | Section |
|----------------------------|---|
| Sensitive attribute | FtpConnectionType HttpConnectionType Complex Type DMQueryTaskQueryStringContainerType DMQueryBuilderSpecificationType PasswordElementType |
| Encrypted attribute | FtpConnectionType HttpConnectionType DMQueryTaskQueryStringContainerType DMQueryBuilderSpecificationType PasswordElementType |

5 Appendix A: Full DTSX XSD

For ease of implementation, the following sections provide the full DTSX syntax for this file format.

| DTSX syntax | Section |
|-------------------|---------------------|
| DTS | 5.1 |
| WebServiceTask | 5.2 |
| MessageQueueTask | 5.3 |
| SendMailTask | 5.4 |
| ActiveXScriptTask | 5.5 |
| Exec80PackageTask | 5.6 |
| BulkInsertTask | 5.7 |
| SQLTask | 5.8 |

5.1 DTS XSD

```
<?xml version="1.0" encoding="utf-8"?>
<xs:schema xmlns:DTS="www.microsoft.com/SqlServer/Dts"
  xmlns:xs="http://www.w3.org/2001/XMLSchema"
  elementFormDefault="qualified"
  attributeFormDefault="qualified"
  targetNamespace="www.microsoft.com/SqlServer/Dts"
  xmlns:WSTask="www.microsoft.com/sqlserver/dts/tasks/webservicetask"
  xmlns:MessageQueueTask=
    "www.microsoft.com/sqlserver/dts/tasks/messagequeuetask"
  xmlns:SendMailTask="www.microsoft.com/sqlserver/dts/tasks/sendmailtask"
  xmlns:ActiveXScriptTask=
    "www.microsoft.com/sqlserver/dts/tasks/activexscripttask"
  xmlns:Exec80PackageTask=
    "www.microsoft.com/sqlserver/dts/tasks/exec80packagetask"
  xmlns:BulkInsertTask=
    "www.microsoft.com/sqlserver/dts/tasks/bulkinsertrightask"
  xmlns:SQLTask="www.microsoft.com/sqlserver/dts/tasks/sqltask"
  >

  <!--Imports-->

  <xs:import namespace=
    "www.microsoft.com/sqlserver/dts/tasks/webservicetask"
    schemaLocation=".ns_webservicetask.xsd" />
  <xs:import namespace=
    "www.microsoft.com/sqlserver/dts/tasks/messagequeuetask"
    schemaLocation=".ns_messagequeuetask.xsd" />
  <xs:import namespace=
    "www.microsoft.com/sqlserver/dts/tasks/sendmailtask"
    schemaLocation=".ns_sendmailtask.xsd" />
  <xs:import namespace=
    "www.microsoft.com/sqlserver/dts/tasks/activexscripttask"
    schemaLocation=".ns_activexscripttask.xsd" />
  <xs:import namespace=
    "www.microsoft.com/sqlserver/dts/tasks/exec80packagetask"
    schemaLocation=".ns_exec80packagetask.xsd" />
  <xs:import namespace=
    "www.microsoft.com/sqlserver/dts/tasks/bulkinsertrightask"
    schemaLocation=".ns_bulkinsertrightask.xsd" />
```

```

<xs:import namespace=
  "www.microsoft.com/sqlserver/dts/tasks/sqltask"
  schemaLocation="./ns_sqltask.xsd" />

<!--Root Element and Root Executables-->

<xs:element name="Executable" type="DTS:ExecutableTypePackage"/>

<xs:complexType name="ExecutableTypePackage">
  <xs:sequence>
    <xs:element name="Property" maxOccurs="unbounded">
      <xs:complexType>
        <xs:complexContent>
          <xs:extension base="DTS:PropertyElementBaseType">
            <xs:attribute name="Name"
              type="DTS:ExecutableTypePackagePropertyNameEnum"
              use="required"/>
          </xs:extension>
        </xs:complexContent>
      </xs:complexType>
    </xs:element>
    <xs:element name="ConnectionManager" type="DTS:ConnectionManagerType"
      minOccurs="0" maxOccurs="unbounded"/>
    <xs:element name="Configuration" type="DTS:ConfigurationType"
      minOccurs="0" maxOccurs="unbounded"/>
    <xs:element name="LogProvider" type="DTS:LogProviderType"
      minOccurs="0" maxOccurs="unbounded"/>
    <xs:element name="Variable" type="DTS:VariableType"
      minOccurs="0" maxOccurs="unbounded"/>
    <xs:element name="LoggingOptions" type="DTS:LoggingOptionsType" />
    <xs:element name="PropertyExpression"
      type="DTS:PropertyExpressionElementType"
      minOccurs="0" maxOccurs="unbounded"/>
    <xs:element name="Executable" type="DTS:AnyNonPackageExecutableType"
      minOccurs="0" maxOccurs="unbounded"/>
    <xs:element name="PrecedenceConstraint"
      type="DTS:PrecedenceConstraintType"
      minOccurs="0" maxOccurs="unbounded"/>
    <xs:element name="EventHandler" type="DTS:EventHandlerType"
      minOccurs="0" maxOccurs="unbounded"/>
    <xs:element name="PackageVariable" type="DTS:PackageVariableType"
      minOccurs="0" maxOccurs="unbounded"/>
  </xs:sequence>
  <xs:attribute name="ExecutableType" use="required"
    fixed="SSIS.Package.2" />
</xs:complexType>

<xs:complexType name="AnyNonPackageExecutableType">
  <xs:sequence>
    <xs:element name="ForEachEnumerator"
      type="DTS:ForEachEnumeratorType"
      minOccurs="0"/>
    <xs:element name="Property"
      maxOccurs="unbounded">
      <xs:complexType>
        <xs:complexContent>
          <xs:extension base="DTS:PropertyElementBaseType">
            <xs:attribute name="Name"
              type="DTS:AnyNonPackageExecutablePropertyNameEnum"
              use="required"/>
          </xs:extension>
        </xs:complexContent>
      </xs:complexType>
    </xs:element>
    <xs:element name="Variable" type="DTS:VariableType"
      minOccurs="0" maxOccurs="unbounded"/>
    <xs:element name="LoggingOptions" type="DTS:LoggingOptionsType" />
    <xs:element name="PropertyExpression"

```

```

        type="DTS:PropertyExpressionElementType"
        minOccurs="0" maxOccurs="unbounded"/>
<xs:element name="Executable" type="DTS:AnyNonPackageExecutableType"
minOccurs="0" maxOccurs="unbounded"/>
<xs:element name="PrecedenceConstraint"
type="DTS:PrecedenceConstraintType"
minOccurs="0" maxOccurs="unbounded"/>
<xs:element name="ForEachVariableMapping"
type="DTS:ForEachVariableMappingType"
minOccurs="0" maxOccurs="unbounded"/>
<xs:element name="EventHandler" type="DTS:EventHandlerType"
minOccurs="0" maxOccurs="unbounded"/>
<xs:element name="ObjectData" type="DTS:ExecutableObjectDataType"
minOccurs="0"/>
</xs:sequence>
<xs:attribute name="ExecutableType" use="required" type="xs:string"/>
<xs:attribute name="ThreadHint" use="optional" type="xs:int"/>
</xs:complexType>

<!--Package Exe contained types-->

<xs:complexType name="PackageVariableType">
  <xs:sequence>
    <xs:element name="Property"
      maxOccurs="unbounded">
      <xs:complexType>
        <xs:complexContent>
          <xs:extension base="DTS:PropertyElementBaseType">
            <xs:attribute name="Name"
              type="DTS:PackageVariablePropertyNameEnum"
              use="required"/>
          </xs:extension>
        </xs:complexContent>
      </xs:complexType>
    </xs:element>
    <xs:element name="PropertyExpression"
      type="DTS:PropertyExpressionElementType"
      minOccurs="0" maxOccurs="unbounded"/>
  </xs:sequence>
</xs:complexType>

<xs:complexType name="ConfigurationType">
  <xs:sequence>
    <xs:element name="Property"
      maxOccurs="unbounded">
      <xs:complexType>
        <xs:complexContent>
          <xs:extension base="DTS:PropertyElementBaseType">
            <xs:attribute name="Name"
              type="DTS:ConfigurationPropertyNameEnum"
              use="required"/>
          </xs:extension>
        </xs:complexContent>
      </xs:complexType>
    </xs:element>
    <xs:element name="PropertyExpression"
      type="DTS:PropertyExpressionElementType"
      minOccurs="0" maxOccurs="unbounded"/>
  </xs:sequence>
</xs:complexType>

<xs:complexType name="LogProviderType" >
  <xs:sequence>
    <xs:element name="Property"
      maxOccurs="unbounded">
      <xs:complexType>
        <xs:complexContent>
          <xs:extension base="DTS:PropertyElementBaseType">
            <xs:attribute name="Name"

```

```

                type="DTS:LogProviderPropertyNameEnum"
                use="required"/>
            </xs:extension>
        </xs:complexContent>
    </xs:complexType>
</xs:element>
<xs:element name="PropertyExpression"
    type="DTS:PropertyExpressionElementType"
    minOccurs="0" maxOccurs="unbounded"/>
<xs:element name="ObjectData" type="DTS:LogProviderObjectDataType"/>
</xs:sequence>
</xs:complexType>

<xs:complexType name="ConnectionManagerType">
    <xs:sequence>
        <xs:element name="Property"
            maxOccurs="unbounded">
            <xs:complexType>
                <xs:complexContent>
                    <xs:extension base="DTS:PropertyElementBaseType">
                        <xs:attribute name="Name"
                            type="DTS:ConnectionManagerPropertyNameEnum"
                            use="required"/>
                    </xs:extension>
                </xs:complexContent>
            </xs:complexType>
        </xs:element>
        <xs:element name="PropertyExpression"
            type="DTS:PropertyExpressionElementType"
            minOccurs="0" maxOccurs="unbounded"/>
        <xs:element name="ObjectData" type="DTS:ConnectionManagerObjectDataType"/>
    </xs:sequence>
</xs:complexType>

<!--AnyNonPackageExecutable Contained Complex Types-->

<xs:complexType name="PrecedenceConstraintType">
    <xs:sequence>
        <xs:element name="Property"
            maxOccurs="unbounded">
            <xs:complexType>
                <xs:complexContent>
                    <xs:extension base="DTS:PropertyElementBaseType">
                        <xs:attribute name="Name"
                            type="DTS:PrecedenceConstraintPropertyNameEnum"
                            use="required"/>
                    </xs:extension>
                </xs:complexContent>
            </xs:complexType>
        </xs:element>
        <xs:element name="PropertyExpression"
            type="DTS:PropertyExpressionElementType"
            minOccurs="0" maxOccurs="unbounded"/>
        <xs:element name="Executable"
            type="DTS:PrecedenceConstraintExecutableReferenceType"
            minOccurs="1" maxOccurs="unbounded"/>
    </xs:sequence>
</xs:complexType>

<xs:complexType name="PrecedenceConstraintExecutableReferenceType">
    <xs:sequence/>
    <xs:attribute name="IDREF" type="DTS:uuid" form="unqualified"/>
    <xs:attribute name="IsFrom">
        <xs:simpleType>
            <xs:restriction base="xs:int">
                <xs:minInclusive value="-1"/>
                <xs:maxInclusive value="0"/>
            </xs:restriction>
        </xs:simpleType>
    </xs:attribute>
</xs:complexType>

```

```

    </xs:attribute>
  </xs:complexType>

  <xs:complexType name="LoggingOptionsType">
    <xs:sequence>
      <xs:element name="Property"
        type="DTS:LoggingOptionsPropertyElementType"
        maxOccurs="unbounded">
      </xs:element>
      <xs:element name="PropertyExpression"
        type="DTS:PropertyExpressionElementType"
        minOccurs="0" maxOccurs="unbounded"/>
      <xs:element name="SelectedLogProvider" minOccurs="0"
        maxOccurs="unbounded" type="DTS:SelectedLogProviderType"/>
    </xs:sequence>
  </xs:complexType>

  <xs:complexType name="LoggingOptionsPropertyElementType" mixed="true">
    <xs:sequence>
      <xs:element name="Property" minOccurs="0" maxOccurs="unbounded">
        <xs:complexType>
          <xs:simpleContent>
            <xs:extension base="xs:anySimpleType">
              <xs:attribute name="Name"
                type="DTS:ColumnEventFilterPropertyNameEnum"
                use="required"/>
              <xs:attribute name="DataType" type="DTS:DtsDataTypeEnum"/>
            </xs:extension>
          </xs:simpleContent>
        </xs:complexType>
      </xs:element>
    </xs:sequence>
    <xs:attribute name="Name"
      type="DTS:LoggingOptionsPropertyNameEnum"
      use="required"/>
    <xs:attribute name="DataType" type="DTS:DtsDataTypeEnum"/>
    <xs:attribute name="EventName" type="xs:string"/>
  </xs:complexType>

  <xs:complexType name="SelectedLogProviderTypeX">
    <xs:simpleContent>
      <xs:extension base="xs:anySimpleType">
        <xs:attribute name="InstanceID" type="DTS:uuid"/>
      </xs:extension>
    </xs:simpleContent>
  </xs:complexType>

  <xs:complexType name="SelectedLogProviderType">
    <xs:sequence/>
    <xs:attribute name="InstanceID" type="DTS:uuid"/>
  </xs:complexType>

  <xs:complexType name="VariableType">
    <xs:sequence>
      <xs:element name="Property"
        maxOccurs="unbounded">
        <xs:complexType>
          <xs:complexContent>
            <xs:extension base="DTS:PropertyElementBaseType">
              <xs:attribute name="Name"
                type="DTS:VariablePropertyNameEnum"
                use="required"/>
            </xs:extension>
          </xs:complexContent>
        </xs:complexType>
      </xs:element>
      <xs:element name="PropertyExpression"
        type="DTS:PropertyExpressionElementType"
        minOccurs="0" maxOccurs="unbounded"/>
    </xs:sequence>
  </xs:complexType>

```

```

<xs:element name="VariableValue" maxOccurs="unbounded" >
  <xs:complexType mixed="true">
    <xs:sequence>
      <xs:any minOccurs="0" maxOccurs="unbounded" processContents="skip"/>
    </xs:sequence>
    <xs:attribute name="DataType" type="DTS:DtsDataTypeEnum"/>
    <xs:attribute name="DataSubType">
      <xs:simpleType>
        <xs:restriction base="xs:string">
          <xs:enumeration value="ManagedSerializable"/>
        </xs:restriction>
      </xs:simpleType>
    </xs:attribute>
  </xs:complexType>
</xs:element>
</xs:sequence>
</xs:complexType>

<xs:complexType name="EventHandlerType">
  <xs:sequence>
    <xs:element name="Property"
      maxOccurs="unbounded">
      <xs:complexType>
        <xs:complexContent>
          <xs:extension base="DTS:PropertyElementBaseType">
            <xs:attribute name="Name"
              type="DTS:EventHandlerPropertyNameEnum"
              use="required"/>
          </xs:extension>
        </xs:complexContent>
      </xs:complexType>
    </xs:element>
    <xs:element name="PropertyExpression"
      type="DTS:PropertyExpressionElementType"
      minOccurs="0" maxOccurs="unbounded"/>
    <xs:element name="Variable" type="DTS:VariableType"
      minOccurs="0" maxOccurs="unbounded"/>
    <xs:element name="LoggingOptions" type="DTS:LoggingOptionsType"/>
    <xs:element name="Executable" type="DTS:AnyNonPackageExecutableType"
      minOccurs="0" maxOccurs="unbounded"/>
    <xs:element name="PrecedenceConstraint"
      type="DTS:PrecedenceConstraintType"
      minOccurs="0" maxOccurs="unbounded"/>
  </xs:sequence>
</xs:complexType>

<xs:complexType name="ForEachEnumeratorType">
  <xs:sequence>
    <xs:element name="Property"
      maxOccurs="unbounded">
      <xs:complexType>
        <xs:complexContent>
          <xs:extension base="DTS:PropertyElementBaseType">
            <xs:attribute name="Name"
              type="DTS:BasePropertyNameEnum"
              use="required"/>
          </xs:extension>
        </xs:complexContent>
      </xs:complexType>
    </xs:element>
    <xs:element name="PropertyExpression"
      type="DTS:PropertyExpressionElementType"
      minOccurs="0" maxOccurs="unbounded"/>
    <xs:element name="ObjectData"
      type="DTS:ForEachEnumeratorObjectDataType"/>
  </xs:sequence>
</xs:complexType>

<xs:complexType name="ForEachVariableMappingType" >

```



```

<xs:sequence>
  <xs:element name="Property"
    maxOccurs="unbounded">
    <xs:complexType>
      <xs:complexContent>
        <xs:extension base="DTS:PropertyElementBaseType">
          <xs:attribute name="Name"
            type="DTS:ForEachVariableMappingPropertyNameEnum"
            use="required"/>
        </xs:extension>
      </xs:complexContent>
    </xs:complexType>
  </xs:element>
  <xs:element name="PropertyExpression"
    type="DTS:PropertyExpressionElementType"
    minOccurs="0" maxOccurs="unbounded"/>
</xs:sequence>
</xs:complexType>

<!--ObjectData Executable Types-->

<xs:complexType name="ExecutableObjectDataType">
  <xs:choice minOccurs="0">
    <xs:element name="pipeline" type="DTS:pipelineObjectDataType"
      form="unqualified"/>
    <xs:element ref="ActiveXScriptTask:ActiveXScriptTaskData" />
    <xs:element name="ASDdlData" type="DTS:ASDdlDataObjectDataType"
      form="unqualified"/>
    <xs:element name="ASProcessingData" form="unqualified"
      type="DTS:ASProcessingDataObjectDataType"/>
    <xs:element ref="BulkInsertTask:BulkInsertTaskData"/>
    <xs:element name="DMQuertTaskData" form="unqualified"
      type="DTS:DMQueryTaskDataObjectDataType"/>
    <xs:element name="DataProfilingTaskData" form="unqualified"
      type="DTS:DataProfilingTaskDataObjectDataType"/>
    <xs:element ref="Exec80PackageTask:Exec80PackageTaskData"/>
    <xs:element name="ExecutePackageTask" form="unqualified"
      type="DTS:ExecutePackageTaskObjectDataType"/>
    <xs:element name="ExecuteProcessData" form="unqualified"
      type="DTS:ExecuteProcessDataObjectDataType"/>
    <xs:element ref="SQLTask:SqlTaskData"/>
    <xs:element name="FileSystemData" form="unqualified"
      type="DTS:FileSystemDataObjectDataType"/>
    <xs:element name="FtpData" type="DTS:FtpDataObjectDataType"
      form="unqualified"/>
    <xs:element ref="MessageQueueTask:MessageQueueTaskData"/>
    <xs:element name="ScriptProject" type="DTS:ScriptProjectObjectDataType"
      form="unqualified"/>
    <xs:element ref="SendMailTask:SendMailTaskData"/>
    <xs:element name="TransferDatabasesTaskData" form="unqualified"
      type="DTS:TransferDatabasesTaskDataObjectDataType"/>
    <xs:element name="TransferErrorMessagesTaskData" form="unqualified"
      type="DTS:TransferErrorMessagesTaskDataObjectDataType"/>
    <xs:element name="TransferJobsTaskData" form="unqualified"
      type="DTS:TransferJobsTaskDataObjectDataType"/>
    <xs:element name="TransferLoginsTaskData" form="unqualified"
      type="DTS:TransferLoginsTaskDataObjectDataType"/>
    <xs:element name="TransferStoredProceduresTaskData" form="unqualified"
      type="DTS:TransferStoredProceduresTaskDataObjectDataType"/>
    <xs:element name="TransferSqlServerObjectsTaskData" form="unqualified"
      type="DTS:TransferSqlServerObjectsTaskDataObjectDataType"/>
    <xs:element ref="WSTask:WebServiceTaskData"/>
    <xs:element name="WMIDRTaskData" type="DTS:WMIDRTaskDataObjectDataType"
      form="unqualified"/>
    <xs:element name="WMIEWTaskData" type="DTS:WMIEWTaskDataObjectDataType"
      form="unqualified"/>
    <xs:element name="XMLTaskData" type="DTS:XMLTaskDataObjectDataType"
      form="unqualified"/>
    <xs:element name="InnerObject" type="DTS:InnerObjectObjectDataType"

```

```

        form="unqualified"/>
    </xs:choice>
</xs:complexType>

<xs:complexType name="ASDdlDataObjectDataType">
    <xs:sequence/>
    <xs:attribute name="ConnectionName" type="xs:string"
        form="unqualified"/>
    <xs:attribute name="SourceType" form="unqualified"
        type="DTS:SourceTypeEnum"/>
    <xs:attribute name="Source" type="xs:string"
        form="unqualified"/>
</xs:complexType>

<xs:complexType name="ASProcessingDataObjectDataType">
    <xs:sequence/>
    <xs:attribute name="ConnectionName" type="xs:string"
        form="unqualified"/>
    <xs:attribute name="ProcessingCommands" type="xs:string"
        form="unqualified"/>
</xs:complexType>

<xs:complexType name="DMQueryTaskDataObjectDataType">
    <xs:sequence>
        <xs:element name="QueryString" form="unqualified"
            type="DTS:DMQueryTaskQueryStringContainerType"/>
        <xs:element name="QueryBuilderQueryString" form="unqualified"
            type="DTS:DMQueryTaskQueryStringContainerType"/>
        <xs:element name="QueryBuilderSpecification" form="unqualified"
            type="DTS:DMQueryBuilderSpecificationType"/>
    </xs:sequence>
    <xs:attribute name="InputConnection" type="xs:string"
        form="unqualified"/>
    <xs:attribute name="OutputConnection" type="xs:string"
        form="unqualified"/>
    <xs:attribute name="ModelStructureName" type="xs:string"
        form="unqualified"/>
    <xs:attribute name="ModelName" type="xs:string" form="unqualified"/>
    <xs:attribute name="OverwriteOutputTable" form="unqualified">
        <xs:simpleType>
            <xs:restriction base="xs:string">
                <xs:enumeration value="True"/>
                <xs:enumeration value="False"/>
            </xs:restriction>
        </xs:simpleType>
    </xs:attribute>
    <xs:attribute name="OutputTableName" type="xs:string"
        form="unqualified"/>
</xs:complexType>

<xs:complexType name="DMQueryTaskQueryStringContainerType">
    <xs:simpleContent>
        <xs:extension base="xs:string">
            <xs:attribute name="Sensitive" type="xs:boolean"
                form="unqualified"/>
            <xs:attribute name="Encrypted" type="xs:boolean"
                form="unqualified"/>
        </xs:extension>
    </xs:simpleContent>
</xs:complexType>

<xs:complexType name="DMQueryBuilderSpecificationType">
    <xs:sequence>
        <xs:any minOccurs="0" maxOccurs="unbounded"
            namespace="##any" processContents="lax"/>
    </xs:sequence>
    <xs:attribute name="Sensitive" type="xs:boolean"
        form="unqualified"/>
    <xs:attribute name="Encrypted" type="xs:boolean"

```

```

        form="unqualified"/>
</xs:complexType>

<xs:complexType name="DataProfilingTaskDataObjectDataType">
  <xs:sequence>
    <xs:element name="ProfileInput" type="xs:string"
      form="unqualified"/>
  </xs:sequence>
  <xs:attribute name="DestinationType" form="unqualified"
    type="DTS:DestinationTypeEnum" />
  <xs:attribute name="Destination" type="xs:string"
    form="unqualified"/>
  <xs:attribute name="OverwriteDestination" form="unqualified">
    <xs:simpleType>
      <xs:restriction base="xs:string">
        <xs:enumeration value="True"/>
        <xs:enumeration value="False"/>
      </xs:restriction>
    </xs:simpleType>
  </xs:attribute>
</xs:complexType>

<xs:simpleType name="DestinationTypeEnum">
  <xs:restriction base="xs:string">
    <xs:enumeration value="FileConnection"/>
    <xs:enumeration value="Variable"/>
  </xs:restriction>
</xs:simpleType>

<xs:complexType name="ExecutePackageTaskObjectDataType">
  <xs:sequence>
    <xs:element name="ExecuteOutOfProcess" form="unqualified">
      <xs:simpleType>
        <xs:restriction base="xs:string">
          <xs:enumeration value="True"/>
          <xs:enumeration value="False"/>
        </xs:restriction>
      </xs:simpleType>
    </xs:element>
    <xs:element name="PackageName" type="xs:string"
      form="unqualified"/>
    <xs:element name="PackagePassword" type="DTS>PasswordElementType"
      form="unqualified"/>
    <xs:element name="PackageID" type="DTS:uuid" form="unqualified"/>
    <xs:element name="VersionID" type="DTS:uuid" form="unqualified"/>
    <xs:element name="Connection" type="xs:string" form="unqualified"/>
  </xs:sequence>
</xs:complexType>

<xs:complexType name="ExecuteProcessDataObjectDataType">
  <xs:sequence>
  </xs:sequence>
  <xs:attribute name="Executable" type="xs:string" form="unqualified"/>
  <xs:attribute name="RequireFullFileName" form="unqualified">
    <xs:simpleType>
      <xs:restriction base="xs:string">
        <xs:enumeration value="True"/>
        <xs:enumeration value="False"/>
      </xs:restriction>
    </xs:simpleType>
  </xs:attribute>
  <xs:attribute name="Arguments" type="xs:string" form="unqualified"/>
  <xs:attribute name="WorkingDirectory" type="xs:string"
    form="unqualified"/>
  <xs:attribute name="TimeOut" type="xs:string" form="unqualified"/>
  <xs:attribute name="FailTaskIfReturnCodeIsNotSuccessValue"
    form="unqualified">
    <xs:simpleType>
      <xs:restriction base="xs:string">

```

```

        <xs:enumeration value="True"/>
        <xs:enumeration value="False"/>
    </xs:restriction>
</xs:simpleType>
</xs:attribute>
<xs:attribute name="SuccessValue" type="xs:string" form="unqualified"/>
<xs:attribute name="TerminateAfterTimeout" form="unqualified">
    <xs:simpleType>
        <xs:restriction base="xs:string">
            <xs:enumeration value="True"/>
            <xs:enumeration value="False"/>
        </xs:restriction>
    </xs:simpleType>
</xs:attribute>
<xs:attribute name="StandardInputVariable" type="xs:string"
    form="unqualified"/>
<xs:attribute name="StandardOutputVariable" type="xs:string"
    form="unqualified"/>
<xs:attribute name="StandardErrorVariable" type="xs:string"
    form="unqualified"/>
<xs:attribute name="WindowStyle" form="unqualified"
    type="DTS:WindowStyleEnum"/>
</xs:complexType>

<xs:simpleType name="WindowStyleEnum">
    <xs:restriction base="xs:string">
        <xs:enumeration value="Hidden"/>
        <xs:enumeration value="Maximized"/>
        <xs:enumeration value="Minimized"/>
        <xs:enumeration value="Normal"/>
    </xs:restriction>
</xs:simpleType>

<xs:complexType name="FileSystemDataObjectDataType">
    <xs:sequence/>
    <xs:attribute name="TaskOperationType" form="unqualified"
        type="DTS:FileSystemTaskOperationTypeEnum"/>
    <xs:attribute name="OperationName" form="unqualified"
        type="xs:string"/>
    <xs:attribute name="TaskOverwriteDestFile" form="unqualified">
        <xs:simpleType>
            <xs:restriction base="xs:string">
                <xs:enumeration value="False"/>
                <xs:enumeration value="True"/>
            </xs:restriction>
        </xs:simpleType>
    </xs:attribute>
    <xs:attribute name="TaskSourcePath" form="unqualified"
        type="xs:string"/>
    <xs:attribute name="TaskIsSourceVariable" form="unqualified">
        <xs:simpleType>
            <xs:restriction base="xs:string">
                <xs:enumeration value="False"/>
                <xs:enumeration value="True"/>
            </xs:restriction>
        </xs:simpleType>
    </xs:attribute>
    <xs:attribute name="TaskDestinationPath" form="unqualified"
        type="xs:string"/>
    <xs:attribute name="TaskIsDestinationVariable" form="unqualified">
        <xs:simpleType>
            <xs:restriction base="xs:string">
                <xs:enumeration value="False"/>
                <xs:enumeration value="True"/>
            </xs:restriction>
        </xs:simpleType>
    </xs:attribute>
    <xs:attribute name="TaskFileAttributes" form="unqualified"
        type="DTS:FileSystemTaskFileAttributesEnum"/>

```

```

</xs:complexType>

<xs:complexType name="FtpDataObjectDataType">
  <xs:sequence>
  </xs:sequence>
  <xs:attribute name="ConnectionName" type="xs:string"
    form="unqualified"/>
  <xs:attribute name="StopOnFailure" form="unqualified">
    <xs:simpleType>
      <xs:restriction base="xs:string">
        <xs:enumeration value="False"/>
        <xs:enumeration value="True"/>
      </xs:restriction>
    </xs:simpleType>
  </xs:attribute>
  <xs:attribute name="TaskOperationType"
    type="DTS:FtpDataTaskOperationTypeEnum"
    form="unqualified"/>
  <xs:attribute name="TaskOperationName" type="xs:string"
    form="unqualified"/>
  <xs:attribute name="TaskIsLocalPathVar" form="unqualified">
    <xs:simpleType>
      <xs:restriction base="xs:string">
        <xs:enumeration value="False"/>
        <xs:enumeration value="True"/>
      </xs:restriction>
    </xs:simpleType>
  </xs:attribute>
  <xs:attribute name="TaskLocalPath" type="xs:string"
    form="unqualified"/>
  <xs:attribute name="TaskIsRemotePathVar" form="unqualified">
    <xs:simpleType>
      <xs:restriction base="xs:string">
        <xs:enumeration value="False"/>
        <xs:enumeration value="True"/>
      </xs:restriction>
    </xs:simpleType>
  </xs:attribute>
  <xs:attribute name="TaskRemotePath" type="xs:string"
    form="unqualified"/>
  <xs:attribute name="TaskOverwriteDest" form="unqualified">
    <xs:simpleType>
      <xs:restriction base="xs:string">
        <xs:enumeration value="False"/>
        <xs:enumeration value="True"/>
      </xs:restriction>
    </xs:simpleType>
  </xs:attribute>
  <xs:attribute name="TaskTransferAscii" form="unqualified">
    <xs:simpleType>
      <xs:restriction base="xs:string">
        <xs:enumeration value="False"/>
        <xs:enumeration value="True"/>
      </xs:restriction>
    </xs:simpleType>
  </xs:attribute>
</xs:complexType>

<xs:simpleType name="FtpDataTaskOperationTypeEnum">
  <xs:restriction base="xs:string">
    <xs:enumeration value="DeleteLocal"/>
    <xs:enumeration value="DeleteRemote"/>
    <xs:enumeration value="MakeDirLocal"/>
    <xs:enumeration value="MakeDirRemote"/>
    <xs:enumeration value="Receive"/>
    <xs:enumeration value="RemoveDirLocal"/>
    <xs:enumeration value="RemoveDirRemote"/>
    <xs:enumeration value="Send"/>
  </xs:restriction>
</xs:simpleType>

```

```

</xs:simpleType>

<xs:complexType name="ScriptProjectObjectDataType">
  <xs:sequence>
    <xs:element name="ProjectItem"
      type="DTS:ScriptProjectProjectItemType"
      minOccurs="0" maxOccurs="unbounded"
      form="unqualified"/>
    <xs:element name="BinaryItem"
      type="DTS:ScriptProjectBinaryItemType"
      minOccurs="0" form="unqualified"/>
    <xs:element name="Breakpoint"
      type="DTS:ScriptProjectBreakpointType"
      minOccurs="0" maxOccurs="unbounded"
      form="unqualified"/>
  </xs:sequence>
  <xs:attribute name="Name" type="xs:string" form="unqualified"/>
  <xs:attribute name="VSTAMajorVersion" type="xs:int"
    form="unqualified"/>
  <xs:attribute name="VSTAMinorVersion" type="xs:int"
    form="unqualified"/>
  <xs:attribute name="Language" type="DTS:ScriptProjectLanguageEnum"
    form="unqualified"/>
  <xs:attribute name="EntryPoint" type="xs:string"
    form="unqualified"/>
  <xs:attribute name="ReadOnlyVariables" type="xs:string"
    form="unqualified"/>
  <xs:attribute name="ReadWriteVariables" type="xs:string"
    form="unqualified"/>
</xs:complexType>

<xs:complexType name="ScriptProjectProjectItemType">
  <xs:simpleContent>
    <xs:extension base="xs:string">
      <xs:attribute name="Name" type="xs:string"
        form="unqualified"/>
    </xs:extension>
  </xs:simpleContent>
</xs:complexType>

<xs:complexType name="ScriptProjectBinaryItemType">
  <xs:simpleContent>
    <xs:extension base="xs:base64Binary">
      <xs:attribute name="Name" type="xs:string"
        form="unqualified"/>
    </xs:extension>
  </xs:simpleContent>
</xs:complexType>

<xs:complexType name="ScriptProjectBreakpointType">
  <xs:sequence/>
  <xs:attribute name="Name" type="xs:string" form="unqualified"/>
  <xs:attribute name="Enabled" type="xs:string"
    form="unqualified"/>
  <xs:attribute name="Function" type="xs:string"
    form="unqualified"/>
  <xs:attribute name="File" type="xs:string" form="unqualified"/>
  <xs:attribute name="Line" type="xs:int" form="unqualified"/>
  <xs:attribute name="Column" type="xs:int" form="unqualified"/>
  <xs:attribute name="Condition" type="xs:string"
    form="unqualified"/>
  <xs:attribute name="ConditionType"
    type="DTS:ScriptProjectConditionTypeEnum"
    form="unqualified"/>
  <xs:attribute name="Language" type="xs:string"
    form="unqualified"/>
  <xs:attribute name="HitCount" type="xs:int" form="unqualified"/>
  <xs:attribute name="HitCountType" form="unqualified"
    type="DTS:ScriptProjectHitCountTypeEnum"/>

```

```

</xs:complexType>

<xs:simpleType name="ScriptProjectLanguageEnum">
  <xs:restriction base="xs:string">
    <xs:enumeration value="CSharp"/>
    <xs:enumeration value="VisualBasic"/>
  </xs:restriction>
</xs:simpleType>

<xs:simpleType name="ScriptProjectHitCountTypeEnum">
  <xs:restriction base="xs:int">
    <xs:minInclusive value="1"/>
    <xs:maxInclusive value="4"/>
  </xs:restriction>
</xs:simpleType>

<xs:simpleType name="ScriptProjectConditionTypeEnum">
  <xs:restriction base="xs:int">
    <xs:minInclusive value="1"/>
    <xs:maxInclusive value="2"/>
  </xs:restriction>
</xs:simpleType>

<xs:complexType name="TransferDatabasesTaskDataObjectDataType">
  <xs:sequence/>
  <xs:attribute name="SrcConn" type="xs:string" form="unqualified"/>
  <xs:attribute name="DestConn" type="xs:string" form="unqualified"/>
  <xs:attribute name="Action" type="DTS:TransferDatabaseTaskActionEnum"
    form="unqualified"/>
  <xs:attribute name="Method" type="DTS:TransferDatabaseTaskMethodEnum"
    form="unqualified"/>
  <xs:attribute name="SrcDBName" type="xs:string" form="unqualified"/>
  <xs:attribute name="ReattachSrcDB" type="xs:boolean"
    form="unqualified"/>
  <xs:attribute name="SrcDBFiles" type="xs:string"
    form="unqualified"/>
  <xs:attribute name="DestDBName" type="xs:string"
    form="unqualified"/>
  <xs:attribute name="DestDBFiles" type="xs:string"
    form="unqualified"/>
  <xs:attribute name="DestOverwrite" type="xs:boolean"
    form="unqualified"/>
</xs:complexType>

<xs:simpleType name="TransferDatabaseTaskActionEnum">
  <xs:restriction base="xs:int">
    <xs:minInclusive value="0"/>
    <xs:maxInclusive value="1"/>
  </xs:restriction>
</xs:simpleType>

<xs:simpleType name="TransferDatabaseTaskMethodEnum">
  <xs:restriction base="xs:int">
    <xs:minInclusive value="0"/>
    <xs:maxInclusive value="1"/>
  </xs:restriction>
</xs:simpleType>

<xs:complexType name="TransferErrorMessagesTaskDataObjectDataType">
  <xs:sequence/>
  <xs:attribute name="TransferAllErrorMessages" type="xs:boolean"
    form="unqualified"/>
  <xs:attribute name="ErrorMessagesList" type="xs:string"
    form="unqualified"/>
  <xs:attribute name="ErrorMessageLanguagesList" type="xs:string"
    form="unqualified"/>
  <xs:attribute name="IfObjectExists"
    type="DTS:IfObjectExistsEnum"
    form="unqualified"/>

```

```

    <xs:attribute name="SourceConnection" type="xs:string"
        form="unqualified"/>
    <xs:attribute name="DestinationConnection" type="xs:string"
        form="unqualified"/>
</xs:complexType>

<xs:simpleType name="IfObjectExistsEnum">
    <xs:restriction base="xs:string">
        <xs:enumeration value="FailTask"/>
        <xs:enumeration value="Overwrite"/>
        <xs:enumeration value="Skip"/>
    </xs:restriction>
</xs:simpleType>

<xs:complexType name="TransferJobsTaskDataObjectDataType">
    <xs:sequence/>
    <xs:attribute name="TransferAllJobs" type="xs:boolean"
        form="unqualified"/>
    <xs:attribute name="JobsList" type="xs:string"
        form="unqualified"/>
    <xs:attribute name="IfObjectExists" type="DTS:IfObjectExistsEnum"
        form="unqualified"/>
    <xs:attribute name="EnableJobsAtDestination" type="xs:boolean"
        form="unqualified"/>
    <xs:attribute name="SourceConnection" type="xs:string"
        form="unqualified"/>
    <xs:attribute name="DestinationConnection" type="xs:string"
        form="unqualified"/>
</xs:complexType>

<xs:complexType name="TransferLoginsTaskDataObjectDataType">
    <xs:sequence/>
    <xs:attribute name="LoginsToTransfer"
        type="DTS:TransferLoginsTaskLoginsToTransferEnum"
        form="unqualified"/>
    <xs:attribute name="CopySids" type="xs:boolean" form="unqualified"/>
    <xs:attribute name="LoginList" type="xs:string" form="unqualified"/>
    <xs:attribute name="IfObjectExists" type="DTS:IfObjectExistsEnum"
        form="unqualified"/>
    <xs:attribute name="SourceConnection" type="xs:string"
        form="unqualified"/>
    <xs:attribute name="DestinationConnection" type="xs:string"
        form="unqualified"/>
    <xs:attribute name="DatabasesList" type="xs:string"
        form="unqualified"/>
</xs:complexType>

<xs:simpleType name="TransferLoginsTaskLoginsToTransferEnum">
    <xs:restriction base="xs:string">
        <xs:enumeration value="SelectedLogins"/>
        <xs:enumeration value="AllLoginsFromSelectedDatabases"/>
        <xs:enumeration value="AllLogins"/>
    </xs:restriction>
</xs:simpleType>

<xs:complexType name="TransferStoredProceduresTaskDataObjectDataType">
    <xs:sequence/>
    <xs:attribute name="TransferAllStoredProcedures"
        type="xs:boolean" form="unqualified"/>
    <xs:attribute name="StoredProceduresList" type="xs:string"
        form="unqualified"/>
    <xs:attribute name="IfObjectExists" type="DTS:IfObjectExistsEnum"
        form="unqualified"/>
    <xs:attribute name="SourceConnection" type="xs:string"
        form="unqualified"/>
    <xs:attribute name="m_DestinationConnectionID"
        type="xs:string" form="unqualified"/>
</xs:complexType>

```



```

<xs:complexType name="TransferSqlServerObjectsTaskDataObjectDataType">
  <xs:sequence/>
  <xs:attribute name="SourceConnection" type="xs:string"
    form="unqualified"/>
  <xs:attribute name="DestinationConnection" type="xs:string"
    form="unqualified"/>
  <xs:attribute name="SourceDatabase" type="xs:string"
    form="unqualified"/>
  <xs:attribute name="DestinationDatabase" type="xs:string"
    form="unqualified"/>
  <xs:attribute name="CopyAllObjects" type="xs:boolean"
    form="unqualified"/>
  <xs:attribute name="CopyAllRules" type="xs:boolean"
    form="unqualified"/>
  <xs:attribute name="CopyAllTables" type="xs:boolean"
    form="unqualified"/>
  <xs:attribute name="CopyAllViews" type="xs:boolean"
    form="unqualified"/>
  <xs:attribute name="CopyAllStoredProcedures"
    type="xs:boolean" form="unqualified"/>
  <xs:attribute name="CopyAllUserDefinedFunctions"
    type="xs:boolean" form="unqualified"/>
  <xs:attribute name="CopyAllDefaults" type="xs:string"
    form="unqualified"/>
  <xs:attribute name="CopyAllUserDefinedDataTypes"
    type="xs:boolean" form="unqualified"/>
  <xs:attribute name="CopyAllPartitionFunctions" type="xs:boolean"
    form="unqualified"/>
  <xs:attribute name="CopyAllPartitionSchemes" type="xs:boolean"
    form="unqualified"/>
  <xs:attribute name="CopyAllSchemas" type="xs:boolean"
    form="unqualified"/>
  <xs:attribute name="CopyAllSqlAssemblies" type="xs:boolean"
    form="unqualified"/>
  <xs:attribute name="CopyAllUserDefinedAggregates"
    type="xs:boolean" form="unqualified"/>
  <xs:attribute name="CopyAllUserDefinedTypes" type="xs:boolean"
    form="unqualified"/>
  <xs:attribute name="CopyAllXmlSchemaCollections" type="xs:boolean"
    form="unqualified"/>
  <xs:attribute name="LoginsList" type="DTS:ListStringType"
    form="unqualified"/>
  <xs:attribute name="UsersList" type="DTS:ListStringType"
    form="unqualified"/>
  <xs:attribute name="RulesList" type="DTS:ListStringType"
    form="unqualified"/>
  <xs:attribute name="TablesList" type="DTS:ListStringType"
    form="unqualified"/>
  <xs:attribute name="ViewsList" type="DTS:ListStringType"
    form="unqualified"/>
  <xs:attribute name="StoredProceduresList"
    type="DTS:ListStringType" form="unqualified"/>
  <xs:attribute name="UserDefinedFunctionsList"
    type="DTS:ListStringType" form="unqualified"/>
  <xs:attribute name="DefaultsList" type="DTS:ListStringType"
    form="unqualified"/>
  <xs:attribute name="UserDefinedDataTypesList"
    type="DTS:ListStringType" form="unqualified"/>
  <xs:attribute name="PartitionFunctionsList" type="DTS:ListStringType"
    form="unqualified"/>
  <xs:attribute name="PartitionSchemesList" type="DTS:ListStringType"
    form="unqualified"/>
  <xs:attribute name="SchemasList" type="DTS:ListStringType"
    form="unqualified"/>
  <xs:attribute name="SqlAssembliesList" type="DTS:ListStringType"
    form="unqualified"/>
  <xs:attribute name="UserDefinedAggregatesList"
    type="DTS:ListStringType" form="unqualified"/>
  <xs:attribute name="UserDefinedTypesList" type="DTS:ListStringType"

```

```

        form="unqualified"/>
<xs:attribute name="XmlSchemaCollectionsList" type="DTS:ListStringType"
form="unqualified"/>
<xs:attribute name="DropObjectsFirst" type="xs:boolean"
form="unqualified"/>
<xs:attribute name="IncludeDependentObjects"
type="xs:boolean" form="unqualified"/>
<xs:attribute name="IncludeExtendedProperties" type="xs:boolean"
form="unqualified"/>
<xs:attribute name="CopyData" type="xs:boolean"
form="unqualified"/>
<xs:attribute name="ExistingData"
type="DTS:TransferSqlServerObjectsTaskExistingDataEnum"
form="unqualified"/>
<xs:attribute name="CopySchema" type="xs:boolean"
form="unqualified"/>
<xs:attribute name="UseCollation" type="xs:boolean"
form="unqualified"/>
<xs:attribute name="CopyDatabaseUsers" type="xs:boolean"
form="unqualified"/>
<xs:attribute name="CopyDatabaseRoles" type="xs:boolean"
form="unqualified"/>
<xs:attribute name="CopySqlServerLogins" type="xs:boolean"
form="unqualified"/>
<xs:attribute name="CopyObjectLevelPermissions" type="xs:boolean"
form="unqualified"/>
<xs:attribute name="CopyIndexes" type="xs:boolean"
form="unqualified"/>
<xs:attribute name="CopyTriggers" type="xs:boolean"
form="unqualified"/>
<xs:attribute name="CopyFullTextIndexes" type="xs:boolean"
form="unqualified"/>
<xs:attribute name="CopyPrimaryKeys" type="xs:boolean"
form="unqualified"/>
<xs:attribute name="CopyForeignKeys" type="xs:boolean"
form="unqualified"/>
<xs:attribute name="GenerateScriptsInUnicode" type="xs:boolean"
form="unqualified"/>
<xs:attribute name="SourceTranslateChar" type="xs:boolean"
form="unqualified"/>
<xs:attribute name="DestinationTranslateChar" type="xs:boolean"
form="unqualified"/>
<xs:attribute name="CopyAllDRIObjects" type="xs:boolean"
form="unqualified"/>
</xs:complexType>

<xs:simpleType name="ListStringType">
  <xs:restriction base="xs:string">
    <xs:pattern value="[0-9]+,?([0-9]+,\.+){0,}" />
  </xs:restriction>
</xs:simpleType>

<xs:simpleType name="TransferSqlServerObjectsTaskExistingDataEnum">
  <xs:restriction base="xs:string">
    <xs:enumeration value="Replace" />
    <xs:enumeration value="Append" />
  </xs:restriction>
</xs:simpleType>

<xs:complexType name="WMIDRTaskDataObjectDataType">
  <xs:sequence/>
  <xs:attribute name="WQLQuerySourceType" type="DTS:SourceTypeEnum"
form="unqualified"/>
  <xs:attribute name="WQLQuerySource" type="xs:string"
form="unqualified"/>
  <xs:attribute name="DestinationType"
type="DTS:DestinationTypeEnum" form="unqualified"/>
  <xs:attribute name="Destination" type="xs:string"
form="unqualified"/>

```

```

    <xs:attribute name="OverwriteDestination"
      type="DTS:WMITaskDataOverwriteDestinationEnum"
      form="unqualified"/>
    <xs:attribute name="OutputType"
      type="DTS:WMITaskDataOutputTypeEnum"
      form="unqualified"/>
    <xs:attribute name="WMIConnectionName" type="xs:string"
      form="unqualified"/>
  </xs:complexType>

  <xs:simpleType name="WMITaskDataOverwriteDestinationEnum">
    <xs:restriction base="xs:string">
      <xs:enumeration value="KeepOriginal"/>
      <xs:enumeration value="AppendToDestination"/>
      <xs:enumeration value="OverwriteDestination"/>
    </xs:restriction>
  </xs:simpleType>

  <xs:simpleType name="WMITaskDataOutputTypeEnum">
    <xs:restriction base="xs:string">
      <xs:enumeration value="DataTable"/>
      <xs:enumeration value="PropertyNameAndValue"/>
      <xs:enumeration value="PropertyValue"/>
    </xs:restriction>
  </xs:simpleType>

  <xs:complexType name="WMI EWTaskDataObjectDataType">
    <xs:sequence/>
    <xs:attribute name="WMIConnectionName" type="xs:string"
      form="unqualified"/>
    <xs:attribute name="WQLQuerySourceType" type="DTS:SourceTypeEnum"
      form="unqualified"/>
    <xs:attribute name="WQLQuerySource" type="xs:string"
      form="unqualified"/>
    <xs:attribute name="ActionAtEvent"
      type="DTS:WMI EWTaskDataActionAtEventEnum"
      form="unqualified"/>
    <xs:attribute name="AfterEvent"
      type="DTS:WMI EWTaskDataAfterEventEnum"
      form="unqualified"/>
    <xs:attribute name="ActionAtTimeout"
      type="DTS:WMI EWTaskDataActionAtTimeoutEnum"
      form="unqualified"/>
    <xs:attribute name="AfterTimeout"
      type="DTS:WMI EWTaskDataAfterEventEnum"
      form="unqualified"/>
    <xs:attribute name="NumberOfEvents" type="xs:int"
      form="unqualified"/>
    <xs:attribute name="Timeout" type="xs:int" form="unqualified"/>
  </xs:complexType>

  <xs:simpleType name="WMI EWTaskDataActionAtEventEnum">
    <xs:restriction base="xs:string">
      <xs:enumeration value="LogTheEventAndFireDTSEvent"/>
      <xs:enumeration value="LogTheEvent"/>
    </xs:restriction>
  </xs:simpleType>

  <xs:simpleType name="WMI EWTaskDataAfterEventEnum">
    <xs:restriction base="xs:string">
      <xs:enumeration value="WatchfortheEventAgain"/>
      <xs:enumeration value="ReturnWithSuccess"/>
      <xs:enumeration value="ReturnWithFailure"/>
    </xs:restriction>
  </xs:simpleType>

  <xs:simpleType name="WMI EWTaskDataActionAtTimeoutEnum">
    <xs:restriction base="xs:string">

```

```

        <xs:enumeration value="LogTimeoutAndFireDTSEvent"/>
        <xs:enumeration value="LogTimeout"/>
    </xs:restriction>
</xs:simpleType>

<xs:complexType name="XMLTaskDataObjectDataType">
    <xs:sequence>
    </xs:sequence>
    <xs:attribute name="OperationType" form="unqualified"
        type="DTS:XMLTaskOperationTypeEnum"/>
    <xs:attribute name="SourceType" type="DTS:SourceTypeEnum"
        form="unqualified"/>
    <xs:attribute name="Source" type="xs:string" form="unqualified"/>
    <xs:attribute name="SecondOperandType" type="DTS:SourceTypeEnum"
        form="unqualified"/>
    <xs:attribute name="SecondOperand" type="xs:string"
        form="unqualified"/>
    <xs:attribute name="SaveOperationResult" form="unqualified">
        <xs:simpleType>
            <xs:restriction base="xs:string">
                <xs:enumeration value="True"/>
                <xs:enumeration value="False"/>
            </xs:restriction>
        </xs:simpleType>
    </xs:attribute>
    <xs:attribute name="DestinationType"
        type="DTS:DestinationTypeEnum" form="unqualified"/>
    <xs:attribute name="Destination" type="xs:string"
        form="unqualified"/>
    <xs:attribute name="OverwriteDestination" form="unqualified">
        <xs:simpleType>
            <xs:restriction base="xs:string">
                <xs:enumeration value="True"/>
                <xs:enumeration value="False"/>
            </xs:restriction>
        </xs:simpleType>
    </xs:attribute>
    <xs:attribute name="FailOpOnValidationFail" form="unqualified">
        <xs:simpleType>
            <xs:restriction base="xs:string">
                <xs:enumeration value="True"/>
                <xs:enumeration value="False"/>
            </xs:restriction>
        </xs:simpleType>
    </xs:attribute>
    <xs:attribute name="FailOpOnDifference" form="unqualified">
        <xs:simpleType>
            <xs:restriction base="xs:string">
                <xs:enumeration value="True"/>
                <xs:enumeration value="False"/>
            </xs:restriction>
        </xs:simpleType>
    </xs:attribute>
    <xs:attribute name="SaveDiffGram" form="unqualified">
        <xs:simpleType>
            <xs:restriction base="xs:string">
                <xs:enumeration value="True"/>
                <xs:enumeration value="False"/>
            </xs:restriction>
        </xs:simpleType>
    </xs:attribute>
    <xs:attribute name="DiffGramDestinationType" form="unqualified"
        type="DTS:DestinationTypeEnum" />
    <xs:attribute name="DiffGramDestination" form="unqualified"
        type="xs:string" />
    <xs:attribute name="DiffOptions" type="DTS:XMLTaskDiffOptionsType"
        form="unqualified"/>
    <xs:attribute name="DiffAlgorithm" form="unqualified"
        type="DTS:XMLTaskDiffAlgorithmEnum" />

```

```

<xs:attribute name="XPathStringSourceType"
  type="DTS:SourceTypeEnum" form="unqualified"/>
<xs:attribute name="XPathStringSource" type="xs:string"
  form="unqualified"/>
<xs:attribute name="XPathOperation" form="unqualified"
  type="DTS:XMLTaskXPathOperationEnum" />
<xs:attribute name="PutResultInOneNode" form="unqualified">
  <xs:simpleType>
    <xs:restriction base="xs:string">
      <xs:enumeration value="True"/>
      <xs:enumeration value="False"/>
    </xs:restriction>
  </xs:simpleType>
</xs:attribute>
<xs:attribute name="ValidationType"
  type="DTS:XMLTaskValidationTypeEnum"
  form="unqualified"/>
</xs:complexType>

<xs:simpleType name="XMLTaskOperationTypeEnum">
  <xs:restriction base="xs:string">
    <xs:enumeration value="Diff"/>
    <xs:enumeration value="Validate"/>
    <xs:enumeration value="Merge"/>
    <xs:enumeration value="XSLT"/>
    <xs:enumeration value="XPATH"/>
    <xs:enumeration value="Patch"/>
  </xs:restriction>
</xs:simpleType>

<xs:simpleType name="XMLTaskDiffOptionsType">
  <xs:restriction base="xs:int">
    <xs:minInclusive value="0"/>
    <xs:maxInclusive value="255"/>
  </xs:restriction>
</xs:simpleType>

<xs:simpleType name="XMLTaskDiffAlgorithmEnum">
  <xs:restriction base="xs:string">
    <xs:enumeration value="Auto"/>
    <xs:enumeration value="Fast"/>
    <xs:enumeration value="Precise"/>
  </xs:restriction>
</xs:simpleType>

<xs:simpleType name="XMLTaskXPathOperationEnum">
  <xs:restriction base="xs:string">
    <xs:enumeration value="Evaluation"/>
    <xs:enumeration value="NodeList"/>
    <xs:enumeration value="Values"/>
  </xs:restriction>
</xs:simpleType>

<xs:simpleType name="XMLTaskValidationTypeEnum">
  <xs:restriction base="xs:string">
    <xs:enumeration value="DTD"/>
    <xs:enumeration value="XSD"/>
  </xs:restriction>
</xs:simpleType>

<xs:complexType name="InnerObjectObjectDataType">
  <xs:sequence>
    <xs:any minOccurs="0" maxOccurs="unbounded"
      namespace="##any" processContents="skip"/>
  </xs:sequence>
</xs:complexType>

<!--Support Types Contained by ObjectData for Executables-->

```

```

<!--pipelineObjectDataType-->
<xs:complexType name="pipelineObjectDataType">
  <xs:sequence>
    <xs:sequence>
      <xs:element name="components" type="DTS:PipelineComponentsType"
        form="unqualified"/>
      <xs:element name="paths" type="DTS:PipelinePathsType"
        minOccurs="0" form="unqualified"/>
    </xs:sequence>
  </xs:sequence>
  <xs:attribute name="id" type="xs:int" form="unqualified"/>
  <xs:attribute name="name" type="xs:string" form="unqualified"/>
  <xs:attribute name="description" type="xs:string"
    form="unqualified"/>
  <xs:attribute name="defaultBufferMaxRows" type="xs:int"
    form="unqualified"/>
  <xs:attribute name="engineThreads" type="xs:int"
    form="unqualified"/>
  <xs:attribute name="defaultBufferSize" type="xs:int"
    form="unqualified"/>
  <xs:attribute name="BLOBTempStoragePath" type="xs:string"
    form="unqualified"/>
  <xs:attribute name="bufferTempStoragePath" type="xs:string"
    form="unqualified"/>
  <xs:attribute name="runInOptimizedMode" type="xs:boolean"
    form="unqualified"/>
</xs:complexType>

<xs:complexType name="PipelineComponentsType">
  <xs:sequence>
    <xs:element name="Component" type="DTS:PipelineComponentType"
      form="unqualified" maxOccurs="unbounded"/>
  </xs:sequence>
</xs:complexType>

<xs:complexType name="PipelinePathsType">
  <xs:sequence>
    <xs:element name="path" type="DTS:PipelinePathType"
      form="unqualified" minOccurs="0" maxOccurs="unbounded"/>
  </xs:sequence>
</xs:complexType>

<xs:complexType name="PipelineComponentType">
  <xs:sequence>
    <xs:element name="properties" form="unqualified"
      type="DTS:PipelineComponentPropertiesType"
      minOccurs="0"/>
    <xs:element name="connections" form="unqualified"
      type="DTS:PipelineComponentConnectionsType"
      minOccurs="0"/>
    <xs:element name="inputs" form="unqualified"
      type="DTS:PipelineComponentInputsType"
      minOccurs="0"/>
    <xs:element name="outputs" form="unqualified"
      type="DTS:PipelineComponentOutputsType"
      minOccurs="0"/>
  </xs:sequence>
  <xs:attribute name="id" type="xs:int" form="unqualified"/>
  <xs:attribute name="name" type="xs:string" form="unqualified"/>
  <xs:attribute name="componentClassID"
    type="DTS:PipelineComponentComponentClassIDEnum"
    form="unqualified"/>
  <xs:attribute name="description" type="xs:string"
    form="unqualified"/>
  <xs:attribute name="localeId" type="xs:int" form="unqualified"/>
  <xs:attribute name="usesDispositions" type="xs:boolean"
    form="unqualified"/>
  <xs:attribute name="validateExternalMetadata" form="unqualified"/>

```

```

    <xs:simpleType>
      <xs:restriction base="xs:string">
        <xs:enumeration value="True"/>
        <xs:enumeration value="False"/>
      </xs:restriction>
    </xs:simpleType>
  </xs:attribute>
  <xs:attribute name="version" type="xs:int" form="unqualified"/>
  <xs:attribute name="pipelineVersion" type="xs:int"
    form="unqualified"/>
  <xs:attribute name="contactInfo" type="xs:string"
    form="unqualified"/>
</xs:complexType>

<xs:complexType name="PipelineComponentPropertiesType">
  <xs:sequence>
    <xs:element name="property" form="unqualified"
      type="DTS:PipelineComponentPropertyType"
      minOccurs="0" maxOccurs="unbounded"/>
  </xs:sequence>
</xs:complexType>

<xs:complexType name="PipelineComponentOutputPropertiesType">
  <xs:sequence>
    <xs:element name="property" form="unqualified"
      type="DTS:PipelineComponentOutputPropertyType"
      minOccurs="0" maxOccurs="unbounded"/>
  </xs:sequence>
</xs:complexType>

<xs:complexType name="PipelineComponentInputPropertiesType">
  <xs:sequence>
    <xs:element name="property" form="unqualified"
      type="DTS:PipelineComponentInputPropertyType"
      minOccurs="0" maxOccurs="unbounded"/>
  </xs:sequence>
</xs:complexType>

<xs:complexType name="PipelineComponentConnectionsType">
  <xs:sequence>
    <xs:element name="connection" form="unqualified"
      type="DTS:PipelineComponentConnectionType"
      minOccurs="0" maxOccurs="unbounded"/>
  </xs:sequence>
</xs:complexType>

<xs:complexType name="PipelineComponentInputsType">
  <xs:sequence>
    <xs:element name="input" form="unqualified"
      type="DTS:PipelineComponentInputType"
      minOccurs="0" maxOccurs="unbounded"/>
  </xs:sequence>
</xs:complexType>

<xs:complexType name="PipelineComponentOutputsType">
  <xs:sequence>
    <xs:element name="output" form="unqualified"
      type="DTS:PipelineComponentOutputType"
      minOccurs="0" maxOccurs="unbounded"/>
  </xs:sequence>
</xs:complexType>

<xs:complexType name="Test">
  <xs:complexContent>
    <xs:restriction base="xs:anyType">
      <xs:sequence>
        <xs:element name="arrayElements" minOccurs="0">
          <xs:complexType>
            <xs:sequence>

```

```

        <xs:any minOccurs="0" maxOccurs="unbounded"/>
      </xs:sequence>
      <xs:anyAttribute namespace="##any" processContents="lax"/>
    </xs:complexType>
  </xs:element>
</xs:sequence>
<xs:anyAttribute namespace="##any" processContents="lax"/>
</xs:restriction>
</xs:complexContent>
</xs:complexType>

<xs:complexType name="PipelineComponentPropertyType" mixed="true">
  <xs:sequence>
    <xs:element name="arrayElements"
      type="DTS:PipelineComponentArrayElementsType"
      form="unqualified" minOccurs="0"/>
  </xs:sequence>
  <xs:attribute name="name"
    type="DTS:PipelineComponentPropertyNameEnum"
    form="unqualified"/>
  <xs:attributeGroup
    ref="DTS:PipelineComponentPropertyAttributeGroup"/>
</xs:complexType>

<xs:attributeGroup
  name="PipelineComponentPropertyAttributeGroup">
  <xs:attribute name="id" type="xs:int" form="unqualified"/>
  <xs:attribute name="dataType"
    type="DTS:PipelineComponentDataTypeEnum"
    form="unqualified"/>
  <xs:attribute name="state"
    type="DTS:PipelineComponentStateEnum"
    form="unqualified"/>
  <xs:attribute name="isArray" type="xs:boolean"
    form="unqualified"/>
  <xs:attribute name="description" type="xs:string"
    form="unqualified"/>
  <xs:attribute name="typeConverter" type="xs:string"
    form="unqualified"/>
  <xs:attribute name="UITypeEditor" type="xs:string"
    form="unqualified"/>
  <xs:attribute name="containsID" type="xs:boolean"
    form="unqualified"/>
  <xs:attribute name="expressionType"
    type="DTS:PipelineComponentExpressionTypeEnum"
    form="unqualified"/>
</xs:attributeGroup>

<xs:complexType name="PipelineComponentOutputPropertyType"
  mixed="true">
  <xs:sequence>
    <xs:element name="arrayElements"
      type="DTS:PipelineComponentArrayElementsType"
      form="unqualified" minOccurs="0"/>
  </xs:sequence>
  <xs:attributeGroup
    ref="DTS:PipelineComponentPropertyAttributeGroup"/>
  <xs:attribute name="name"
    type="DTS:PipelineComponentOutputPropertyNameEnum"
    form="unqualified"/>
</xs:complexType>

<xs:complexType name="PipelineComponentInputPropertyType"
  mixed="true">
  <xs:sequence>
    <xs:element name="arrayElements"
      type="DTS:PipelineComponentArrayElementsType"
      form="unqualified" minOccurs="0"/>
  </xs:sequence>

```



```

<xs:attributeGroup
  ref="DTS:PipelineComponentPropertyAttributeGroup"/>
<xs:attribute name="name"
  type="DTS:PipelineComponentInputPropertyNameEnum"
  form="unqualified"/>
</xs:complexType>

<xs:complexType name="PipelineComponentArrayElementsType">
  <xs:sequence>
    <xs:element name="arrayElement"
      type="DTS:PipelineComponentArrayElementType"
      form="unqualified" minOccurs="0" maxOccurs="unbounded"/>
  </xs:sequence>
  <xs:attribute name="arrayElementCount" type="xs:int"
    form="unqualified"/>
</xs:complexType>

<xs:complexType name="PipelineComponentArrayElementType">
  <xs:simpleContent>
    <xs:extension base="xs:anySimpleType">
      <xs:attribute name="dataType"
        type="DTS:PipelineComponentDataTypeEnum"
        form="unqualified"/>
    </xs:extension>
  </xs:simpleContent>
</xs:complexType>

<xs:simpleType name="PipelineComponentComponentClassIDEnum">
  <xs:restriction base="DTS:uuid">
    <!--Transforms-->
    <!--Aggregate-->
    <xs:enumeration value="{9ABE8DF3-0052-42DB-8B18-2089E1D1D1B7}"/>
    <!--Audit-->
    <xs:enumeration value="{32711D35-7D9D-44E5-B57E-A17D33D5C38C}"/>
    <!--Cache Transform-->
    <xs:enumeration value="{A236DD44-4409-433E-A1CE-283DA18F4E0F}"/>
    <!--Character Map-->
    <xs:enumeration value="{DEC33219-BA68-4FEB-AC98-9C1B1E577A8D}"/>
    <!--Conditional Split-->
    <xs:enumeration value="{3AE878C6-0D6C-4F48-8128-40E00E9C1B7D}"/>
    <!--Copy Column-->
    <xs:enumeration value="{98F16A65-E02F-4B0F-87D4-C217EA074619}"/>
    <!--Data Conversion-->
    <xs:enumeration value="{BD06A22E-BC69-4AF7-A69B-C44C2EF684BB}"/>
    <!--Data Mining Query-->
    <xs:enumeration value="{9C58B013-AF30-455F-B809-50F425AFBCAC}"/>
    <!--Derived Column-->
    <xs:enumeration value="{2932025B-AB99-40F6-B5B8-783A73F80E24}"/>
    <!--Export Column-->
    <xs:enumeration value="{86151302-DCDB-49FB-92FE-772EC02712B6}"/>
    <!--Fuzzy Grouping-->
    <xs:enumeration value="{0A1BDBA0-9C6E-4AD7-97B1-E0E79E462629}"/>
    <!--Fuzzy Lookup-->
    <xs:enumeration value="{5056651F-F227-4978-94DF-53CDF9E8CCB6}"/>
    <!--Import Column-->
    <xs:enumeration value="{C8AEEE54-67A0-41A8-821D-D1C8BED62C68}"/>
    <!--Lookup-->
    <xs:enumeration value="{27648839-180F-45E6-838D-AFF53DF682D2}"/>
    <!--Merge-->
    <xs:enumeration value="{D3FC84FA-748F-40B4-A967-F1574F917BE5}"/>
    <!--MergeJoin-->
    <xs:enumeration value="{A18A4D58-7C7A-4448-8B98-AE2CEFE81B4C}"/>
    <!--Multicast-->
    <xs:enumeration value="{1ACA4459-ACE0-496F-814A-8611F9C27E23}"/>
    <!--OLE DB Command-->
    <xs:enumeration value="{8E61C8F6-C91D-43B6-97EB-3423C06571CC}"/>
    <!--Percentage Sampling-->
    <xs:enumeration value="{CEFEB125-5BB5-4F91-A349-94B8961C641B}"/>
    <!--Pivot-->
  </xs:restriction>

```

```

<xs:enumeration value="{DD5A6456-8430-422B-9F50-7EF5A1B63CA8}"/>
<!--RowCount-->
<xs:enumeration value="{150E6007-7C6A-4CC3-8FF3-FC73783A972E}"/>
<!--Row Sampling-->
<xs:enumeration value="{A44C46A3-0A3F-454B-B3BD-0BC23D4BCE94}"/>
<!--Script Component, ADO.Net source, XML Source,ADO.Net
Destination, DataReader Destination, SQL Server Compact Destination-->
<xs:enumeration value="{2E42D45B-F83C-400F-8D77-61DDE6A7DF29}"/>
<!--Slowly Changing Dimension-->
<xs:enumeration value="{70909A92-ECE9-486D-B17E-30EDE908849E}"/>
<!--Sort-->
<xs:enumeration value="{07127A7C-164B-422A-AD1F-24BE39B4DB38}"/>
<!--Term Extraction-->
<xs:enumeration value="{119D450D-E2A3-4DB0-A7BC-ACDE2536673E}"/>
<!--Term Lookup-->
<xs:enumeration value="{4CC3A325-9885-48B4-B451-147C2D523646}"/>
<!--Union All-->
<xs:enumeration value="{4D9F9B7C-84D9-4335-ADB0-2542A7E35422}"/>
<!--Unpivot-->
<xs:enumeration value="{8F25687E-2ACA-4EF3-88A3-53099FDAAF43}"/>

<!--Destinations-->
<!--Excel Destination-->
<xs:enumeration value="{C9269E28-EBDE-4DED-91EB-0BF42842F9F4}"/>
<!--Flat File Destination-->
<xs:enumeration value="{D658C424-8CF0-441C-B3C4-955E183B7FBA}"/>
<!--OLE DB Destination-->
<xs:enumeration value="{5A0B62E8-D91D-49F5-94A5-7BE58DE508F0}"/>
<!--Data Mining Model Training-->
<xs:enumeration value="{0183D6BA-8792-4602-A6AB-6DF19E7F9979}"/>
<!--Dimension Processing-->
<xs:enumeration value="{7D1B6DD6-C1A9-416E-9E7F-31400E3F7249}"/>
<!--Partition Processing-->
<xs:enumeration value="{DCDA2491-C4A4-4C84-9253-119AEF1A4CD7}"/>
<!--Raw File Destination-->
<xs:enumeration value="{485E7329-8754-42B4-AA5B-29C5DA09CAD5}"/>
<!--RecordSet Destination-->
<xs:enumeration value="{167AF7E9-BA81-425F-B73D-E30C2DCC0F09}"/>
<!--SQL Server Destination-->
<xs:enumeration value="{E4B61516-847B-4BDF-9CC6-1968A2D43E73}"/>

<!--Sources-->
<!--Excel Source-->
<xs:enumeration value="{A4B1E1C8-17F3-46C8-AAD0-34F0C6FE42DE}"/>
<!--Flat File Source-->
<xs:enumeration value="{5ACD952A-F16A-41D8-A681-713640837664}"/>
<!--OLE DB Source-->
<xs:enumeration value="{BCEFE59B-6819-47F7-A125-63753B33ABB7}"/>
<!--Raw File Source-->
<xs:enumeration value="{51DC0B24-7421-45C3-B4AB-9481A683D91D}"/>
</xs:restriction>
</xs:simpleType>

<xs:simpleType name="PipelineComponentPropertyNameEnum">
  <xs:restriction base="xs:string">
    <!--Transforms-->
    <!--Aggregate Task-->
    <xs:enumeration value="KeyScale"/>
    <xs:enumeration value="Keys"/>
    <xs:enumeration value="CountDistinctScale"/>
    <xs:enumeration value="CountDistinctKeys"/>
    <xs:enumeration value="AutoExtendFactor"/>
    <!--Audit (none)-->
    <!--Cache Transform (none)-->
    <!--Character Map (none)-->
    <!--Conditional Split (none)-->
    <!--Copy Column (none)-->
    <!--Data Conversion (none)-->
    <!--Data Mining Query-->

```

```

<xs:enumeration value="ObjectRef"/>
<xs:enumeration value="QueryText"/>
<xs:enumeration value="CatalogName"/>
<!--Derived Column Query (none)-->
<!--Export Column Query (none)-->
<!--Fuzzy Grouping-->
<xs:enumeration value="MinSimilarity"/>
<xs:enumeration value="Delimiters"/>
<xs:enumeration value="MaxMemoryUsage"/>
<xs:enumeration value="Exhaustive"/>
<!--Fuzzy Lookup-->
<xs:enumeration value="MatchIndexOptions"/>
<xs:enumeration value="MaxMemoryUsage"/>
<xs:enumeration value="MatchIndexName"/>
<xs:enumeration value="ReferenceTableName"/>
<xs:enumeration value="DropExistingMatchIndex"/>
<xs:enumeration value="CopyReferenceTable"/>
<xs:enumeration value="MaxOutputMatchesPerInput"/>
<xs:enumeration value="MinSimilarity"/>
<xs:enumeration value="Delimiters"/>
<xs:enumeration value="ReferenceMetadataXml"/>
<xs:enumeration value="Exhaustive"/>
<xs:enumeration value="WarmCaches"/>
<!--Import Column (none)-->
<!--Lookup-->
<xs:enumeration value="SqlCommand"/>
<xs:enumeration value="SqlCommandParam"/>
<xs:enumeration value="ConnectionType"/>
<xs:enumeration value="CacheType"/>
<xs:enumeration value="NoMatchBehavior"/>
<xs:enumeration value="NoMatchCachePercentage"/>
<xs:enumeration value="MaxMemoryUsage"/>
<xs:enumeration value="MaxMemoryUsage64"/>
<xs:enumeration value="ReferenceMetadataXml"/>
<xs:enumeration value="ParameterMap"/>
<xs:enumeration value="DefaultCodePage"/>
<!--Merge (none)-->
<!--MergeJoin (none)-->
<xs:enumeration value="JoinType"/>
<xs:enumeration value="NumKeyColumns"/>
<xs:enumeration value="TreatNullsAsEqual"/>
<xs:enumeration value="MaxBuffersPerInput"/>
<!--Multicast (none)-->
<!--OLE DB Command-->
<xs:enumeration value="CommandTimeout"/>
<xs:enumeration value="SqlCommand"/>
<xs:enumeration value="DefaultCodePage"/>
<!--Percentage Sampling-->
<xs:enumeration value="SamplingValue"/>
<xs:enumeration value="SamplingSeed"/>
<!--Pivot (none)-->
<!--RowCount-->
<xs:enumeration value="VariableName"/>
<!--Row Sampling-->
<xs:enumeration value="SamplingValue"/>
<xs:enumeration value="SamplingSeed"/>
<!--Script Component-->
<xs:enumeration value="SourceCode"/>
<xs:enumeration value="BinaryCode"/>
<xs:enumeration value="VSTAProjectName"/>
<xs:enumeration value="ScriptLanguage"/>
<xs:enumeration value="ReadOnlyVariables"/>
<xs:enumeration value="ReadWriteVariables"/>
<xs:enumeration value="BreakpointCollection"/>
<xs:enumeration value="UserComponentTypeName"/>
<!--Slowly Changing Dimension-->
<xs:enumeration value="SqlCommand"/>
<xs:enumeration value="CurrentRowWhere"/>
<xs:enumeration value="UpdateChangingAttributeHistory"/>

```

```

<xs:enumeration value="FailOnFixedAttributeChange"/>
<xs:enumeration value="InferredMemberIndicator"/>
<xs:enumeration value="EnableInferredMember"/>
<xs:enumeration value="FailOnLookupFailure"/>
<xs:enumeration value="IncomingRowChangeType"/>
<xs:enumeration value="DefaultCodePage"/>
<!--Sort-->
<xs:enumeration value="EliminateDuplicates"/>
<xs:enumeration value="MaximumThreads"/>
<!--Term Extraction-->
<xs:enumeration value="NeedReferenceData"/>
<xs:enumeration value="OutTermTable"/>
<xs:enumeration value="OutTermColumn"/>
<xs:enumeration value="WordOrPhrase"/>
<xs:enumeration value="ScoreType"/>
<xs:enumeration value="FrequencyThreshold"/>
<xs:enumeration value="MaxLengthOfTerm"/>
<xs:enumeration value="IsCaseSensitive"/>
<!--Term Lookup-->
<xs:enumeration value="RefTermTable"/>
<xs:enumeration value="RefTermColumn"/>
<xs:enumeration value="IsCaseSensitive"/>
<!--UnionAll (none)-->
<!--Unpivot (none)-->

<!--Data Destinations-->
<!--ADO.Net Destination-->
<xs:enumeration value="TableOrViewName"/>
<xs:enumeration value="BatchSize"/>
<xs:enumeration value="CommandTimeout"/>
<xs:enumeration value="UserComponentTypeName"/>
<!--Excel Destination-->
<xs:enumeration value="CommandTimeout"/>
<xs:enumeration value="OpenRowset"/>
<xs:enumeration value="OpenRowsetVariable"/>
<xs:enumeration value="SqlCommand"/>
<xs:enumeration value="AccessMode"/>
<xs:enumeration value="FastLoadKeepIdentity"/>
<xs:enumeration value="FastLoadKeepNulls"/>
<xs:enumeration value="FastLoadOptions"/>
<xs:enumeration value="FastLoadMaxInsertCommitSize"/>
<!--Flat File Destination-->
<xs:enumeration value="Overwrite"/>
<xs:enumeration value="Header"/>
<!--OLE DB Destination-->
<xs:enumeration value="CommandTimeout"/>
<xs:enumeration value="OpenRowset"/>
<xs:enumeration value="OpenRowsetVariable"/>
<xs:enumeration value="SqlCommand"/>
<xs:enumeration value="DefaultCodePage"/>
<xs:enumeration value="AlwaysUseDefaultCodePage"/>
<xs:enumeration value="AccessMode"/>
<xs:enumeration value="FastLoadKeepIdentity"/>
<xs:enumeration value="FastLoadKeepNulls"/>
<xs:enumeration value="FastLoadOptions"/>
<xs:enumeration value="FastLoadMaxInsertCommitSize"/>
<!--Raw File Destination-->
<xs:enumeration value="AccessMode"/>
<xs:enumeration value="FileName"/>
<xs:enumeration value="FileNameVariable"/>
<xs:enumeration value="WriteOption"/>
<!--DataReader Destination-->
<xs:enumeration value="ReadTimeout"/>
<xs:enumeration value="DataReader"/>
<xs:enumeration value="FailOnTimeout"/>
<xs:enumeration value="UserComponentTypeName"/>
<!--Data Mining Model Training-->
<xs:enumeration value="ObjectRef"/>
<!--Dimension Processing-->

```

```

<xs:enumeration value="ObjectRef"/>
<xs:enumeration value="UseDefaultConfiguration"/>
<xs:enumeration value="KeyErrorLimit"/>
<xs:enumeration value="KeyErrorLogFile"/>
<xs:enumeration value="KeyErrorAction"/>
<xs:enumeration value="KeyErrorLimitAction"/>
<xs:enumeration value="KeyNotFound"/>
<xs:enumeration value="KeyDuplicate"/>
<xs:enumeration value="NullKeyConvertedToUnknown"/>
<xs:enumeration value="NullKeyNotAllowed"/>
<xs:enumeration value="ProcessType"/>
<!--Partition Processing-->
<xs:enumeration value="ObjectRef"/>
<xs:enumeration value="UseDefaultConfiguration"/>
<xs:enumeration value="KeyErrorLimit"/>
<xs:enumeration value="KeyErrorLogFile"/>
<xs:enumeration value="KeyErrorAction"/>
<xs:enumeration value="KeyErrorLimitAction"/>
<xs:enumeration value="KeyNotFound"/>
<xs:enumeration value="KeyDuplicate"/>
<xs:enumeration value="NullKeyConvertedToUnknown"/>
<xs:enumeration value="NullKeyNotAllowed"/>
<xs:enumeration value="ProcessType"/>
<!--RecordSet Destination-->
<xs:enumeration value="VariableName"/>
<!--SQL Server Compact Destination-->
<xs:enumeration value="Table Name"/>
<xs:enumeration value="UserComponentTypeName"/>
<!--SQL Server Destination-->
<xs:enumeration value="DefaultCodePage"/>
<xs:enumeration value="AlwaysUseDefaultCodePage"/>
<xs:enumeration value="BulkInsertTableName"/>
<xs:enumeration value="BulkInsertCheckConstraints"/>
<xs:enumeration value="BulkInsertFirstRow"/>
<xs:enumeration value="BulkInsertFireTriggers"/>
<xs:enumeration value="BulkInsertKeepIdentity"/>
<xs:enumeration value="BulkInsertKeepNulls"/>
<xs:enumeration value="BulkInsertLastRow"/>
<xs:enumeration value="BulkInsertMaxErrors"/>
<xs:enumeration value="BulkInsertOrder"/>
<xs:enumeration value="BulkInsertTablock"/>
<xs:enumeration value="Timeout"/>
<xs:enumeration value="MaxInsertCommitSize"/>

<!--Data Sources-->
<!--ADO.Net Source-->
<xs:enumeration value="SqlCommand"/>
<xs:enumeration value="CommandTimeout"/>
<xs:enumeration value="AllowImplicitStringConversion"/>
<xs:enumeration value="TableOrViewName"/>
<xs:enumeration value="AccessMode"/>
<xs:enumeration value="UserComponentTypeName"/>
<!--Excel Source-->
<xs:enumeration value="CommandTimeout"/>
<xs:enumeration value="OpenRowset"/>
<xs:enumeration value="OpenRowsetVariable"/>
<xs:enumeration value="SqlCommand"/>
<xs:enumeration value="SqlCommandVariable"/>
<xs:enumeration value="AccessMode"/>
<xs:enumeration value="ParameterMapping"/>
<!--Flat File Source-->
<xs:enumeration value="RetainNulls"/>
<xs:enumeration value="FileNameColumnName"/>
<!--OLEDB Source Task-->
<xs:enumeration value="CommandTimeout"/>
<xs:enumeration value="OpenRowset"/>
<xs:enumeration value="OpenRowsetVariable"/>
<xs:enumeration value="SqlCommand"/>
<xs:enumeration value="SqlCommandVariable"/>

```

```

    <xs:enumeration value="DefaultCodePage"/>
    <xs:enumeration value="AlwaysUseDefaultCodePage"/>
    <xs:enumeration value="AccessMode"/>
    <xs:enumeration value="ParameterMapping"/>
    <!--Raw File Source-->
    <xs:enumeration value="AccessMode"/>
    <xs:enumeration value="FileName"/>
    <xs:enumeration value="FileNameVariable"/>
    <!--XML Source-->
    <xs:enumeration value="UserComponentTypeName"/>
    <xs:enumeration value="XMLData"/>
    <xs:enumeration value="XMLDataVariable"/>
    <xs:enumeration value="AccessMode"/>
    <xs:enumeration value="XMLSchemaDefinition"/>
    <xs:enumeration value="UseInlineSchema"/>

  </xs:restriction>
</xs:simpleType>

<xs:simpleType name="PipelineComponentOutputPropertyNameEnum">
  <xs:restriction base="xs:string">
    <!--Transforms-->
    <!--Aggregate Task-->
    <xs:enumeration value="KeyScale"/>
    <xs:enumeration value="Keys"/>
    <!--Audit (none)-->
    <!--Cache Transform (none)-->
    <!--Character Map (none)-->
    <!--Conditional Split-->
    <xs:enumeration value="Expression"/>
    <xs:enumeration value="FriendlyExpression"/>
    <xs:enumeration value="EvaluationOrder"/>
    <xs:enumeration value="IsDefaultOut"/>
    <!--Copy Column (none)-->
    <!--Data Conversion (none)-->
    <!--Data Mining Query (none)-->
    <!--Derived Column Query (none)-->
    <!--Export Column Query (none)-->
    <!--Fuzzy Grouping (none)-->
    <!--Fuzzy Lookup (none)-->
    <!--Import Column (none)-->
    <!--Lookup (none)-->
    <!--Merge (none)-->
    <!--MergeJoin (none)-->
    <!--Multicast (none)-->
    <!--OLE DB Command (none)-->
    <!--Percentage Sampling-->
    <xs:enumeration value="Selected"/>
    <!--Pivot (none)-->
    <!--RowCount (none)-->
    <!--Row Sampling-->
    <xs:enumeration value="Selected"/>
    <!--Script Component (none)-->
    <!--Slowly Changing Dimension (none)-->
    <!--Sort (none)-->
    <!--Term Extraction (none)-->
    <!--Term Lookup (none)-->
    <!--UnionAll (none)-->
    <!--Unpivot (none)-->

    <!--Data Sources (none)-->
    <!--ADO.Net Source (none)-->
    <!--Excel Source (none)-->
    <!--Flat File Source (none)-->
    <!--OLEDB Source Task (none)-->
    <!--Raw File Source (none)-->
    <!--XML Source-->
    <xs:enumeration value="RowsetID"/>
  </xs:restriction>

```

```

</xs:simpleType>

<xs:simpleType name="PipelineComponentInputPropertyNameEnum">
  <xs:restriction base="xs:string">
    </xs:restriction>
    <!--None of the components have defined properties for
the Input element-->
  </xs:simpleType>

<xs:simpleType name="PipelineComponentOutputColumnPropertyNameEnum">
  <xs:restriction base="xs:string">
    <!--Transforms-->
    <!--Aggregate Task-->
    <xs:enumeration value="AggregationColumnId"/>
    <xs:enumeration value="AggregationType"/>
    <xs:enumeration value="IsBig"/>
    <xs:enumeration value="AggregationComparisonFlags"/>
    <xs:enumeration value="CountDistinctKey"/>
    <xs:enumeration value="CountDistinctScale"/>
    <!--Audit-->
    <xs:enumeration value="LineageItemSelected"/>
    <!--Cache Transform (none)-->
    <!--Character Map (none)-->
    <!--Conditional Split (none)-->
    <!--Copy Column (none)-->
    <xs:enumeration value="CopyColumnId"/>
    <!--Data Conversion (none)-->
    <xs:enumeration value="SourceInputColumnLineageID"/>
    <xs:enumeration value="FastParse"/>
    <!--Data Mining Query-->
    <!--Derived Column Query (none)-->
    <xs:enumeration value="Expression"/>
    <xs:enumeration value="FriendlyExpression"/>
    <!--Export Column Query (none)-->
    <!--Fuzzy Grouping-->
    <xs:enumeration value="ColumnType"/>
    <xs:enumeration value="InputId"/>
    <!--Fuzzy Lookup-->
    <xs:enumeration value="CopyFromReferenceColumn"/>
    <xs:enumeration value="SourceInputColumnLineageID"/>
    <xs:enumeration value="ColumnType"/>
    <!--Import Column (none)-->
    <!--Lookup-->
    <xs:enumeration value="CopyFromReferenceColumn"/>
    <!--Merge (none)-->
    <!--MergeJoin-->
    <xs:enumeration value="InputColumnID"/>
    <!--Multicast (none)-->
    <!--OLE DB Command (none)-->
    <!--Percentage Sampling (none)-->
    <!--Pivot-->
    <xs:enumeration value="SourceColumn"/>
    <xs:enumeration value="PivotKeyValue"/>
    <!--RowCount (none)-->
    <!--Row Sampling-->
    <xs:enumeration value="InputColumnLineageID"/>
    <!--Script Component (none)-->
    <!--Slowly Changing Dimension (none)-->
    <!--Sort-->
    <xs:enumeration value="SortColumnId"/>
    <!--Term Extraction (none)-->
    <!--Term Lookup-->
    <xs:enumeration value="CustomLineageID"/>
    <!--UnionAll (none)-->
    <!--Unpivot (none)-->
    <xs:enumeration value="PivotKey"/>

    <!--Data Sources-->
    <!--ADO.Net Source (none)-->

```

```

    <!--Excel Source (none)-->
    <!--Flat File Source-->
    <xs:enumeration value="FastParse"/>
    <xs:enumeration value="UseBinaryFormat"/>
    <!--OLEDB Source Task (none)-->
    <!--Raw File Source (none)-->
    <!--XML Source (none)-->
  </xs:restriction>
</xs:simpleType>

<xs:simpleType name="PipelineComponentInputColumnNameEnum">
  <xs:restriction base="xs:string">
    <!--Transforms-->
    <!--Aggregate Task-->
    <!--Audit (none)-->
    <!--Cache Transform-->
    <xs:enumeration value="CacheColumnName"/>
    <!--Character Map-->
    <xs:enumeration value="MapFlags"/>
    <!--Conditional Split (none)-->
    <!--Copy Column (none)-->
    <!--Data Conversion (none)-->
    <!--Data Mining Query (none)-->
    <!--Derived Column Query-->
    <xs:enumeration value="Expression"/>
    <xs:enumeration value="FriendlyExpression"/>
    <!--Export Column-->
    <xs:enumeration value="FileDataColumnID"/>
    <xs:enumeration value="WriteBOM"/>
    <xs:enumeration value="ForceTruncate"/>
    <xs:enumeration value="AllowAppend"/>
    <!--Fuzzy Grouping, Fuzzy Lookup-->
    <xs:enumeration value="ToBeCleaned"/>
    <xs:enumeration value="ExactFuzzy"/>
    <xs:enumeration value="LeadingTrailingNumeralsSignificant"/>
    <xs:enumeration value="MinSimilarity"/>
    <xs:enumeration value="FuzzyComparisonFlags"/>
    <!--Import Column-->
    <xs:enumeration value="FileDataColumnID"/>
    <xs:enumeration value="ExpectBOM"/>
    <!--Lookup-->
    <xs:enumeration value="JoinToReferenceColumn"/>
    <xs:enumeration value="CopyFromReferenceColumn"/>
    <!--Merge-->
    <xs:enumeration value="OutputColumnLineageID"/>
    <!--MergeJoin (none)-->
    <!--Multicast (none)-->
    <!--OLE DB Command (none)-->
    <!--Percentage Sampling (none)-->
    <!--Pivot-->
    <xs:enumeration value="PivotUsage"/>
    <!--RowCount (none)-->
    <!--Row Sampling (none)-->
    <!--Script Component (none)-->
    <!--Slowly Changing Dimension-->
    <xs:enumeration value="ColumnType"/>
    <!--Sort-->
    <xs:enumeration value="NewComparisonFlags"/>
    <xs:enumeration value="NewSortKeyPosition"/>
    <!--Term Extraction (none)-->
    <!--Term Lookup-->
    <xs:enumeration value="InputColumnType"/>
    <!--UnionAll-->
    <xs:enumeration value="OutputColumnLineageID"/>
    <!--Unpivot-->
    <xs:enumeration value="DestinationColumn"/>
    <xs:enumeration value="PivotKeyValue"/>

    <!--Data Destinations-->
  </xs:restriction>
</xs:simpleType>

```



```

    <!--ADO.Net Destination(none)-->
    <!--Excel Destination(none)-->
    <!--Flat File Destination(none)-->
    <!--OLE DB Destination(none)-->
    <!--Raw File Destination(none)-->
    <!--DataReader Destination(none)-->
    <!--Data Mining Model Training(none)-->
    <!--Dimension Processing(none)-->
    <!--Partition Processing(none)-->
    <!--RecordSet Destination(none)-->
    <!--SQL Server Compact Destination(none)-->
    <!--SQL Server Destination(none)-->
  </xs:restriction>
</xs:simpleType>

<xs:simpleType name="PipelineComponentDataTypeEnum">
  <xs:restriction base="xs:string">
    <xs:enumeration value="System.Boolean"/>
    <xs:enumeration value="System.Byte"/>
    <xs:enumeration value="System.SByte"/>
    <xs:enumeration value="System.Decimal"/>
    <xs:enumeration value="System.Double"/>
    <xs:enumeration value="System.Single"/>
    <xs:enumeration value="System.Int32"/>
    <xs:enumeration value="System.UInt32"/>
    <xs:enumeration value="System.Int64"/>
    <xs:enumeration value="System.UInt64"/>
    <xs:enumeration value="System.Int16"/>
    <xs:enumeration value="System.UInt16"/>
    <xs:enumeration value="System.String"/>
    <xs:enumeration value="System.Null"/>
    <xs:enumeration value="System.DateTime"/>
    <xs:enumeration value="System.Object"/>
  </xs:restriction>
</xs:simpleType>

<xs:simpleType name="PipelineComponentStateEnum">
  <xs:restriction base="xs:string">
    <xs:enumeration value="cdata"/>
    <xs:enumeration value="escaped"/>
    <xs:enumeration value="default"/>
  </xs:restriction>
</xs:simpleType>

<xs:simpleType name="PipelineComponentExpressionTypeEnum">
  <xs:restriction base="xs:string">
    <xs:enumeration value="None"/>
    <xs:enumeration value="Notify"/>
  </xs:restriction>
</xs:simpleType>

<xs:complexType name="PipelineComponentConnectionType">
  <xs:sequence/>
  <xs:attribute name="id" type="xs:int" form="unqualified"/>
  <xs:attribute name="name" type="xs:string" form="unqualified"/>
  <xs:attribute name="description" type="xs:string"
    form="unqualified"/>
  <xs:attribute name="connectionManagerID" type="DTS:uuid"
    form="unqualified"/>
</xs:complexType>

<xs:complexType name="PipelineComponentInputType">
  <xs:sequence>
    <xs:element name="properties"
      type="DTS:PipelineComponentInputPropertiesType"
      minOccurs="0" form="unqualified"/>
    <xs:element name="inputColumns"
      type="DTS:PipelineComponentInputColumnsType"
      minOccurs="0" form="unqualified"/>
  </xs:sequence>
</xs:complexType>

```

```

        <xs:element name="externalMetadataColumns"
            type="DTS:PipelineComponentMetadataColumnsType"
            minOccurs="0" form="unqualified"/>
    </xs:sequence>
    <xs:attributeGroup
        ref="DTS:PipelineComponentInputOutputElementAttributeGroup"/>
</xs:complexType>

<xs:complexType name="PipelineComponentInputColumnsType">
    <xs:sequence>
        <xs:element name="inputColumn"
            type="DTS:PipelineComponentInputColumnType"
            minOccurs="0" maxOccurs="unbounded" form="unqualified"/>
    </xs:sequence>
</xs:complexType>

<xs:complexType name="PipelineComponentInputColumnType">
    <xs:sequence>
        <xs:element name="properties"
            type="DTS:PipelineComponentInputColumnPropertiesType"
            form="unqualified" minOccurs="0" maxOccurs="unbounded"/>
    </xs:sequence>
    <xs:attributeGroup
        ref="DTS:PipelineComponentAllColumnBaseAttributeGroup"/>
    <xs:attributeGroup
        ref="DTS:PipelineComponentIOColumnBaseAttributeGroup"/>
    <xs:attribute name="usageType" form="unqualified"
        type="DTS:PipelineComponentUsageTypeEnum"/>
</xs:complexType>

<xs:complexType name="PipelineComponentInputColumnPropertiesType">
    <xs:sequence>
        <xs:element name="property" form="unqualified"
            type="DTS:PipelineComponentInputColumnPropertyType"
            minOccurs="0" maxOccurs="unbounded"/>
    </xs:sequence>
</xs:complexType>

<xs:complexType name="PipelineComponentInputColumnPropertyType">
    <xs:simpleContent>
        <xs:extension base="xs:anySimpleType">
            <xs:attributeGroup
                ref="DTS:PipelineComponentPropertyAttributeGroup"/>
            <xs:attribute name="name" form="unqualified"
                type="DTS:PipelineComponentInputColumnPropertyNameEnum"/>
        </xs:extension>
    </xs:simpleContent>
</xs:complexType>

<xs:complexType name="PipelineComponentOutputColumnPropertiesType">
    <xs:sequence>
        <xs:element name="property" form="unqualified"
            type="DTS:PipelineComponentOutputColumnPropertyType"
            minOccurs="0" maxOccurs="unbounded"/>
    </xs:sequence>
</xs:complexType>

<xs:complexType name="PipelineComponentOutputColumnPropertyType">
    <xs:simpleContent>
        <xs:extension base="xs:anySimpleType">
            <xs:attributeGroup
                ref="DTS:PipelineComponentPropertyAttributeGroup"/>
            <xs:attribute name="name" form="unqualified"
                type="DTS:PipelineComponentOutputColumnPropertyNameEnum"/>
        </xs:extension>
    </xs:simpleContent>
</xs:complexType>

<xs:simpleType name="PipelineComponentUsageTypeEnum">

```

```

    <xs:restriction base="xs:string">
      <xs:enumeration value="readOnly"/>
      <xs:enumeration value="readWrite"/>
      <xs:enumeration value="Ignored"/>
    </xs:restriction>
  </xs:simpleType>

  <xs:complexType name="PipelineComponentOutputType">
    <xs:sequence>
      <xs:element name="properties"
        type="DTS:PipelineComponentOutputPropertiesType"
        minOccurs="0" form="unqualified"/>
      <xs:element name="outputColumns"
        type="DTS:PipelineComponentOutputColumnsType"
        minOccurs="0" form="unqualified"/>
      <xs:element name="externalMetadataColumns"
        type="DTS:PipelineComponentMetadataColumnsType"
        minOccurs="0" form="unqualified"/>
    </xs:sequence>
    <xs:attributeGroup
      ref="DTS:PipelineComponentInputOutputElementAttributeGroup"/>
    <xs:attribute name="exclusionGroup" type="xs:int"
      form="unqualified"/>
    <xs:attribute name="synchronousInputId" type="xs:string"
      form="unqualified"/>
    <xs:attribute name="deleteOutputOnPathDetached" type="xs:boolean"
      form="unqualified"/>
    <xs:attribute name="isErrorOut" type="xs:boolean"
      form="unqualified"/>
    <xs:attribute name="isSorted" type="xs:boolean" form="unqualified"/>
  </xs:complexType>

  <xs:complexType name="PipelineComponentMetadataColumnsType">
    <xs:sequence>
      <xs:element name="externalMetadataColumn"
        type="DTS:PipelineComponentMetadataColumnType"
        minOccurs="0" maxOccurs="unbounded" form="unqualified"/>
    </xs:sequence>
    <xs:attribute name="isUsed" form="unqualified">
      <xs:simpleType>
        <xs:restriction base="xs:string">
          <xs:enumeration value="True"/>
          <xs:enumeration value="False"/>
        </xs:restriction>
      </xs:simpleType>
    </xs:attribute>
  </xs:complexType>

  <xs:complexType name="PipelineComponentMetadataColumnType">
    <xs:sequence>
      <xs:element name="properties"
        type="DTS:PipelineComponentMetadataColumnPropertiesType"
        minOccurs="0" form="unqualified"/>
    </xs:sequence>
    <xs:attributeGroup
      ref="DTS:PipelineComponentAllColumnBaseAttributeGroup"/>
    <xs:attributeGroup
      ref="DTS:PipelineComponentColumnExtendedAttributeGroup"/>
  </xs:complexType>

  <xs:complexType name="PipelineComponentMetadataColumnPropertiesType">
    <xs:sequence>
      <xs:element name="property"
        type="DTS:PipelineComponentMetadataColumnPropertyType"
        minOccurs="0" maxOccurs="unbounded" form="unqualified"/>
    </xs:sequence>
  </xs:complexType>

  <xs:complexType name="PipelineComponentMetadataColumnPropertyType">

```

```

<xs:simpleContent>
  <xs:extension base="xs:anySimpleType">
    <xs:attributeGroup
      ref="DTS:PipelineComponentPropertyAttributeGroup"/>
    <xs:attribute name="name" form="unqualified"
      type="DTS:PipelineComponentMetadataColumnNamePropertyTypeEnum"/>
  </xs:extension>
</xs:simpleContent>
</xs:complexType>

<xs:simpleType name="PipelineComponentMetadataColumnNamePropertyTypeEnum">
  <xs:restriction base="xs:string">
    <!--OLE DB Command-->
    <xs:enumeration value="DBParamInfoFlags"/>
    <!--XML Source-->
    <xs:enumeration value="CLRType"/>
  </xs:restriction>
</xs:simpleType>

<xs:attributeGroup
  name="PipelineComponentInputOutputElementAttributeGroup">
  <xs:attribute name="id" type="xs:int" form="unqualified"/>
  <xs:attribute name="name" type="xs:string" form="unqualified"/>
  <xs:attribute name="description" type="xs:string"
    form="unqualified"/>
  <xs:attribute name="hasSideEffects" type="xs:boolean"
    form="unqualified"/>
  <xs:attribute name="dangling" type="xs:boolean"
    form="unqualified"/>
  <xs:attribute name="errorOrTruncationOperation" type="xs:string"
    form="unqualified"/>
  <xs:attribute name="errorRowDisposition" form="unqualified"
    type="DTS:PipelineComponentRowDispositionEnum"/>
  <xs:attribute name="truncationRowDisposition" form="unqualified"
    type="DTS:PipelineComponentRowDispositionEnum" />
</xs:attributeGroup>

<xs:attributeGroup name="PipelineComponentAllColumnBaseAttributeGroup">
  <xs:attribute name="id" type="xs:int" form="unqualified"/>
  <xs:attribute name="name" type="xs:string" form="unqualified"/>
  <xs:attribute name="description" type="xs:string" form="unqualified"/>
  <xs:attribute name="mappedColumnId" type="xs:int" form="unqualified"/>
</xs:attributeGroup>

<xs:attributeGroup name="PipelineComponentIOColumnBaseAttributeGroup">
  <xs:attribute name="errorOrTruncationOperation" type="xs:string"
    form="unqualified"/>
  <xs:attribute name="errorRowDisposition"
    type="DTS:PipelineComponentRowDispositionEnum"
    form="unqualified"/>
  <xs:attribute name="truncationRowDisposition"
    type="DTS:PipelineComponentRowDispositionEnum"
    form="unqualified"/>
  <xs:attribute name="externalMetadataColumnId" type="xs:int"
    form="unqualified"/>
  <xs:attribute name="lineageId" type="xs:int" form="unqualified"/>
</xs:attributeGroup>

<xs:attributeGroup name="PipelineComponentColumnExtendedAttributeGroup">
  <xs:attribute name="precision" type="xs:int" form="unqualified"/>
  <xs:attribute name="scale" type="xs:int" form="unqualified"/>
  <xs:attribute name="length" type="xs:int" form="unqualified"/>
  <xs:attribute name="dataType"
    type="DTS:PipelineComponentColumnDataTypeEnum"
    form="unqualified"/>
  <xs:attribute name="codePage" type="xs:int" form="unqualified"/>
</xs:attributeGroup>

<xs:complexType name="PipelineComponentOutputColumnsType">

```

```

<xs:sequence>
  <xs:element name="outputColumn"
    type="DTS:PipelineComponentOutputColumnType"
    minOccurs="0" maxOccurs="unbounded" form="unqualified"/>
</xs:sequence>
</xs:complexType>

<xs:complexType name="PipelineComponentOutputColumnType">
  <xs:sequence>
    <xs:element name="properties"
      type="DTS:PipelineComponentOutputColumnPropertiesType"
      form="unqualified" minOccurs="0" maxOccurs="unbounded"/>
  </xs:sequence>
  <xs:attributeGroup
    ref="DTS:PipelineComponentAllColumnBaseAttributeGroup"/>
  <xs:attributeGroup
    ref="DTS:PipelineComponentIOColumnBaseAttributeGroup"/>
  <xs:attributeGroup
    ref="DTS:PipelineComponentColumnExtendedAttributeGroup"/>
  <xs:attribute name="sortKeyPosition" type="xs:int"
    form="unqualified"/>
  <xs:attribute name="comparisonFlags" type="xs:int"
    form="unqualified"/>
  <xs:attribute name="specialFlags" form="unqualified">
    <xs:simpleType>
      <xs:restriction base="xs:int">
        <xs:minInclusive value="0"/>
        <xs:maxInclusive value="2"/>
      </xs:restriction>
    </xs:simpleType>
  </xs:attribute>
</xs:complexType>

<xs:simpleType name="PipelineComponentColumnDataTypeEnum">
  <xs:restriction base="xs:string">
    <xs:enumeration value="i1"/>
    <xs:enumeration value="ui1"/>
    <xs:enumeration value="i2"/>
    <xs:enumeration value="i4"/>
    <xs:enumeration value="r4"/>
    <xs:enumeration value="r8"/>
    <xs:enumeration value="cy"/>
    <xs:enumeration value="date"/>
    <xs:enumeration value="bool"/>
    <xs:enumeration value="variant"/>
    <xs:enumeration value="decimal"/>
    <xs:enumeration value="ui2"/>
    <xs:enumeration value="ui4"/>
    <xs:enumeration value="i8"/>
    <xs:enumeration value="ui8"/>
    <xs:enumeration value="guid"/>
    <xs:enumeration value="bytes"/>
    <xs:enumeration value="str"/>
    <xs:enumeration value="wstr"/>
    <xs:enumeration value="numeric"/>
    <xs:enumeration value="dbDate"/>
    <xs:enumeration value="dateTime"/>
    <xs:enumeration value="dbTime"/>
    <xs:enumeration value="dbTimeStamp"/>
    <xs:enumeration value="image"/>
    <xs:enumeration value="text"/>
    <xs:enumeration value="nText"/>
    <xs:enumeration value="dbTime2"/>
    <xs:enumeration value="dbTimeStamp2"/>
    <xs:enumeration value="dbTimeStampOffset"/>
  </xs:restriction>
</xs:simpleType>

<xs:simpleType name="PipelineComponentRowDispositionEnum">

```

```

    <xs:restriction base="xs:string">
      <xs:enumeration value="NotUsed"/>
      <xs:enumeration value="IgnoreFailure"/>
      <xs:enumeration value="FailComponent"/>
      <xs:enumeration value="RedirectRow"/>
    </xs:restriction>
  </xs:simpleType>

  <xs:complexType name="PipelinePathType">
    <xs:sequence>
      <xs:attribute name="id" type="xs:int" form="unqualified"/>
      <xs:attribute name="name" type="xs:string" form="unqualified"/>
      <xs:attribute name="description" type="xs:string"
        form="unqualified"/>
      <xs:attribute name="startId" type="xs:int" form="unqualified"/>
      <xs:attribute name="endId" type="xs:int" form="unqualified"/>
    </xs:complexType>

  <!--ObjectData for non-Executables-->

  <xs:complexType name="LogProviderObjectDataType">
    <xs:sequence>
      <xs:element name="InnerObject" form="unqualified"
        type="DTS:InnerObjectObjectDataType"/>
    </xs:sequence>
  </xs:complexType>

  <xs:complexType name="ForEachEnumeratorObjectDataType">
    <xs:choice>
      <xs:element name="FEIEItems" type="DTS:FEIEItemsType"
        form="unqualified"/>
      <xs:element name="ForEachFileEnumeratorProperties"
        type="DTS:ForEachFileEnumeratorPropertiesType"
        form="unqualified"/>
      <xs:element name="FEEADO" type="DTS:FEEADOType"
        form="unqualified"/>
      <xs:element name="FEESchemaRowset" type="DTS:FEESchemaRowsetType"
        form="unqualified"/>
      <xs:element name="FEEFVE" type="DTS:FEEFVEType" form="unqualified"/>
      <xs:element name="FEENODELIST" type="DTS:FEENODELISTType"
        form="unqualified"/>
      <xs:element name="FEESMO" type="DTS:FEESMOType" form="unqualified"/>
    </xs:choice>
  </xs:complexType>

  <xs:complexType name="FEIEItemsType">
    <xs:sequence>
      <xs:element name="FEIEItem" type="DTS:FEIEItemType"
        maxOccurs="unbounded" form="unqualified"/>
    </xs:sequence>
  </xs:complexType>

  <xs:complexType name="FEIEItemType">
    <xs:sequence>
      <xs:element name="FEIEItemValue" maxOccurs="unbounded"
        form="unqualified" type="DTS:FEIEItemValueType"/>
    </xs:sequence>
  </xs:complexType>

  <xs:complexType name="FEIEItemValueType">
    <xs:sequence/>
    <xs:attribute name="Type" type="DTS:DtsDataTypeEnum"
      use="required" form="unqualified"/>
    <xs:attribute name="Value" type="xs:string"
      use="required" form="unqualified"/>
  </xs:complexType>

  <xs:complexType name="ForEachFileEnumeratorPropertiesType">
    <xs:sequence>

```

```

<xs:element name="FEFEProperty" maxOccurs="unbounded" form="unqualified">
  <xs:complexType>
    <xs:sequence/>
    <xs:attribute name="Folder" form="unqualified"/>
    <xs:attribute name="FileSpec" form="unqualified"/>
    <xs:attribute name="FileNameRetrievalType" form="unqualified">
      <xs:simpleType>
        <xs:restriction base="xs:int">
          <xs:minInclusive value="0"/>
          <xs:maxInclusive value="2"/>
        </xs:restriction>
      </xs:simpleType>
    </xs:attribute>
    <xs:attribute name="Recurse" form="unqualified">
      <xs:simpleType>
        <xs:restriction base="xs:int">
          <xs:minInclusive value="-1"/>
          <xs:maxInclusive value="0"/>
        </xs:restriction>
      </xs:simpleType>
    </xs:attribute>
  </xs:complexType>
</xs:element>
</xs:sequence>
</xs:complexType>

<xs:complexType name="FEEADOType">
  <xs:sequence/>
  <xs:attribute name="EnumType" use="required" form="unqualified"
    type="DTS:FEEADOEnumType"/>
  <xs:attribute name="VarName" type="xs:string"
    use="required" form="unqualified"/>
</xs:complexType>

<xs:simpleType name="FEEADOEnumType">
  <xs:restriction base="xs:string">
    <xs:enumeration value="EnumerateRowsInFirstTable"/>
    <xs:enumeration value="EnumerateAllRows"/>
    <xs:enumeration value="EnumerateTables"/>
  </xs:restriction>
</xs:simpleType>

<xs:complexType name="FEESchemaRowsetType">
  <xs:sequence>
    <xs:element name="Restriction" maxOccurs="unbounded"
      form="unqualified" type="DTS:RestrictionElementType"/>
  </xs:sequence>
  <xs:attribute name="Connection" type="xs:string"
    use="required" form="unqualified"/>
  <xs:attribute name="Schema" type="DTS:uuid"
    use="required" form="unqualified"/>
</xs:complexType>

<xs:complexType name="RestrictionElementType">
  <xs:sequence/>
  <xs:attribute name="Index" type="xs:int" use="required"
    form="unqualified"/>
  <xs:attribute name="Value" type="xs:string" use="required"
    form="unqualified"/>
</xs:complexType>

<xs:complexType name="FEEFVEType">
  <xs:sequence/>
  <xs:attribute name="VariableName" type="xs:string" form="unqualified" use="required"/>
</xs:complexType>

<xs:complexType name="FEENODELISTType">
  <xs:sequence/>
  <xs:attribute name="EnumerationType"

```

```

        type="DTS:NodelistEnumerationTypeEnum"
        form="unqualified" use="required"/>
<xs:attribute name="OuterXPathSourceType" form="unqualified"
use="required" type="DTS:SourceTypeEnum"/>
<xs:attribute name="OuterXPathString" type="xs:string"
form="unqualified" use="required"/>
<xs:attribute name="InnerElementType"
type="DTS:NodelistInnerElementEnumerationTypeEnum"
use="required" form="unqualified"/>
<xs:attribute name="InnerXPathSourceType" form="unqualified"
use="required" type="DTS:SourceTypeEnum"/>
<xs:attribute name="InnerXPathString" type="xs:string"
form="unqualified" use="required"/>
<xs:attribute name="SourceType" form="unqualified"
use="required" type="DTS:SourceTypeEnum"/>
<xs:attribute name="SourceDocument" type="xs:string"
use="required" form="unqualified"/>
</xs:complexType>

<xs:simpleType name="NodelistInnerElementEnumerationTypeEnum">
  <xs:restriction base="xs:string">
    <xs:enumeration value="Navigator"/>
    <xs:enumeration value="Node"/>
    <xs:enumeration value="NodeText"/>
  </xs:restriction>
</xs:simpleType>

<xs:simpleType name="NodelistEnumerationTypeEnum">
  <xs:restriction base="xs:string">
    <xs:enumeration value="Navigator"/>
    <xs:enumeration value="Node"/>
    <xs:enumeration value="NodeText"/>
    <xs:enumeration value="ElementCollection"/>
  </xs:restriction>
</xs:simpleType>

<xs:complexType name="FEESMOType">
  <xs:sequence/>
  <xs:attribute name="EnumURN" type="xs:string" form="unqualified" use="required"/>
</xs:complexType>

<xs:complexType name="ConnectionManagerObjectDataType">
  <xs:choice>
    <xs:element name="ConnectionManager" type=
      "DTS:ConnectionManagerObjectDataConnectionManagerType"/>
    <xs:element name="MsmqConnectionManager" type=
      "DTS:ConnectionManagerObjectDataMsmqConnectionManagerType"
      form="unqualified"/>
    <xs:element name="SMOServerConnectionManager" type=
      "DTS:ConnectionManagerObjectDataSMOServerConnectionManagerType"
      form="unqualified"/>
    <xs:element name="SmtplibConnectionManager" type=
      "DTS:ConnectionManagerObjectDataSmtplibConnectionManagerType"
      form="unqualified"/>
    <xs:element name="WmiConnectionManager" type=
      "DTS:ConnectionManagerObjectDataWmiConnectionManagerType"
      form="unqualified"/>
  </xs:choice>
</xs:complexType>

<xs:complexType
name="ConnectionManagerObjectDataConnectionManagerType">
  <xs:sequence>
    <xs:element name="Property"
      minOccurs="0" maxOccurs="unbounded">
      <xs:complexType>
        <xs:complexContent>
          <xs:extension base="DTS:PropertyElementBaseType">
            <xs:attribute name="Name"

```



```

        type="DTS:ConnectionManagerObjectDataPropertyNameEnum"
        use="required"/>
    </xs:extension>
</xs:complexContent>
</xs:complexType>
</xs:element>
<xs:choice minOccurs="0">
    <xs:element name="FlatFileColumn" type="DTS:FlatFileColumnType"
        minOccurs="0" maxOccurs="unbounded"/>
    <xs:element name="CacheColumn" type="DTS:CacheColumnType"
        minOccurs="0" maxOccurs="unbounded"/>
    <xs:element name="FtpConnection" type="DTS:FtpConnectionType"/>
    <xs:element name="HttpConnection" type="DTS:HttpConnectionType"/>
</xs:choice>
</xs:sequence>
</xs:complexType>

<xs:complexType name="FlatFileColumnType">
    <xs:sequence>
        <xs:element name="Property"
            minOccurs="0" maxOccurs="unbounded">
            <xs:complexType>
                <xs:complexContent>
                    <xs:extension base="DTS:PropertyElementBaseType">
                        <xs:attribute name="Name"
                            type="DTS:FlatFileColumnPropertyNameEnum"
                            use="required"/>
                    </xs:extension>
                </xs:complexContent>
            </xs:complexType>
        </xs:element>
    </xs:sequence>
</xs:complexType>

<xs:complexType name="CacheColumnType">
    <xs:sequence>
        <xs:element name="Property"
            minOccurs="0" maxOccurs="unbounded">
            <xs:complexType>
                <xs:complexContent>
                    <xs:extension base="DTS:PropertyElementBaseType">
                        <xs:attribute name="Name"
                            type="DTS:CacheColumnPropertyNameEnum"
                            use="required"/>
                    </xs:extension>
                </xs:complexContent>
            </xs:complexType>
        </xs:element>
    </xs:sequence>
</xs:complexType>

<xs:complexType name="FtpConnectionType">
    <xs:sequence>
        <xs:element name="Property"
            minOccurs="0" maxOccurs="unbounded">
            <xs:complexType>
                <xs:complexContent>
                    <xs:extension base="DTS:PropertyElementBaseType">
                        <xs:attribute name="Name"
                            type="DTS:FtpConnectionPropertyNameEnum"
                            use="required"/>
                        <xs:attribute name="Sensitive" form="unqualified">
                            <xs:simpleType>
                                <xs:restriction base="xs:int">
                                    <xs:minInclusive value="0"/>
                                    <xs:maxInclusive value="1"/>
                                </xs:restriction>
                            </xs:simpleType>
                        </xs:attribute>
                    </xs:extension>
                </xs:complexContent>
            </xs:complexType>
        </xs:element>
    </xs:sequence>
</xs:complexType>

```

```

        <xs:attribute name="Encrypted" form="unqualified">
          <xs:simpleType>
            <xs:restriction base="xs:int">
              <xs:minInclusive value="0"/>
              <xs:maxInclusive value="1"/>
            </xs:restriction>
          </xs:simpleType>
        </xs:attribute>
      </xs:extension>
    </xs:complexContent>
  </xs:complexType>
</xs:element>
</xs:sequence>
</xs:complexType>

<xs:complexType name="HttpConnectionType">
  <xs:sequence>
    <xs:element name="Property"
      minOccurs="0" maxOccurs="unbounded">
      <xs:complexType>
        <xs:complexContent>
          <xs:extension base="DTS:PropertyElementBaseType">
            <xs:attribute name="Name"
              type="DTS:HttpConnectionPropertyNameEnum"
              use="required"/>
            <xs:attribute name="Sensitive" form="unqualified">
              <xs:simpleType>
                <xs:restriction base="xs:int">
                  <xs:minInclusive value="0"/>
                  <xs:maxInclusive value="1"/>
                </xs:restriction>
              </xs:simpleType>
            </xs:attribute>
            <xs:attribute name="Encrypted" form="unqualified">
              <xs:simpleType>
                <xs:restriction base="xs:int">
                  <xs:minInclusive value="0"/>
                  <xs:maxInclusive value="1"/>
                </xs:restriction>
              </xs:simpleType>
            </xs:attribute>
          </xs:extension>
        </xs:complexContent>
      </xs:complexType>
    </xs:element>
  </xs:sequence>
</xs:complexType>

<xs:complexType
  name="ConnectionManagerObjectDataMsmqConnectionManagerType">
  <xs:sequence/>
  <xs:attribute name="ConnectionString" type="xs:string"
    form="unqualified"/>
</xs:complexType>

<xs:complexType
  name="ConnectionManagerObjectDataSMOServerConnectionManagerType">
  <xs:sequence>
    <xs:element name="PassWord" type=
      "DTS>PasswordElementType"
      form="unqualified"/>
  </xs:sequence>
  <xs:attribute name="ConnectionString" type="xs:string"
    form="unqualified" use="required"/>
</xs:complexType>

<xs:complexType name="PasswordElementType">
  <xs:simpleContent>
    <xs:extension base="xs:string">

```

```

    <xs:attribute name="Sensitive" form="unqualified">
      <xs:simpleType>
        <xs:restriction base="xs:int">
          <xs:minInclusive value="0"/>
          <xs:maxInclusive value="1"/>
        </xs:restriction>
      </xs:simpleType>
    </xs:attribute>
    <xs:attribute name="Encrypted" form="unqualified">
      <xs:simpleType>
        <xs:restriction base="xs:int">
          <xs:minInclusive value="0"/>
          <xs:maxInclusive value="1"/>
        </xs:restriction>
      </xs:simpleType>
    </xs:attribute>
  </xs:extension>
</xs:simpleContent>
</xs:complexType>

<xs:complexType
  name="ConnectionManagerObjectDataSmtplibConnectionManagerType">
  <xs:sequence/>
  <xs:attribute name="ConnectionString" type="xs:string"
    form="unqualified"/>
</xs:complexType>

<xs:complexType
  name="ConnectionManagerObjectDataWmiConnectionManagerType">
  <xs:sequence>
    <xs:element name="PassWord" type=
      "DTS:PasswordElementType"
      form="unqualified"/>
  </xs:sequence>
  <xs:attribute name="ConnectionString" type="xs:string"
    form="unqualified"/>
</xs:complexType>

<!--Property Element Types-->

<xs:complexType name="PropertyElementBaseType">
  <xs:simpleContent>
    <xs:extension base="xs:anySimpleType">
      <xs:attribute name="DataType" type="DTS:DtsDataTypeEnum"/>
    </xs:extension>
  </xs:simpleContent>
</xs:complexType>

<xs:complexType name="PropertyExpressionElementType">
  <xs:simpleContent>
    <xs:extension base="xs:anySimpleType">
      <xs:attribute name="Name" type="xs:string" use="required"/>
    </xs:extension>
  </xs:simpleContent>
</xs:complexType>

<!--Enumeration Types-->

<xs:simpleType name="BasePropertyNameEnum">
  <xs:restriction base="xs:string">
    <xs:enumeration value="Description"/>
    <xs:enumeration value="DTSID"/>
    <xs:enumeration value="CreationName"/>
    <xs:enumeration value="ObjectName"/>
  </xs:restriction>
</xs:simpleType>

<xs:simpleType name="DtsDataTypeEnum">
  <xs:restriction base="xs:int">

```

```

    <xs:enumeration value="2"/>
    <xs:enumeration value="3"/>
    <xs:enumeration value="4"/>
    <xs:enumeration value="5"/>
    <xs:enumeration value="6"/>
    <xs:enumeration value="7"/>
    <xs:enumeration value="8"/>
    <xs:enumeration value="11"/>
    <xs:enumeration value="13"/>
    <xs:enumeration value="16"/>
    <xs:enumeration value="17"/>
    <xs:enumeration value="18"/>
    <xs:enumeration value="19"/>
    <xs:enumeration value="20"/>
    <xs:enumeration value="21"/>
    <xs:enumeration value="22"/>
    <xs:enumeration value="23"/>
  </xs:restriction>
</xs:simpleType>

<xs:simpleType name="AllExecutablePropertyNameEnum">
  <xs:union memberTypes="DTS:BaseExecutablePropertyNameEnum">
    <xs:simpleType>
      <xs:restriction base="xs:string">
        <xs:enumeration value="DisableEventHandlers"/>
      </xs:restriction>
    </xs:simpleType>
  </xs:union>
</xs:simpleType>

<xs:simpleType name="BaseExecutablePropertyNameEnum">
  <xs:union memberTypes="DTS:BasePropertyNameEnum">
    <xs:simpleType>
      <xs:restriction base="xs:string">
        <xs:enumeration value="ForceExecValue"/>
        <xs:enumeration value="ExecValue"/>
        <xs:enumeration value="ForceExecutionResult"/>
        <xs:enumeration value="Disabled"/>
        <xs:enumeration value="FailPackageOnFailure"/>
        <xs:enumeration value="FailParentOnFailure"/>
        <xs:enumeration value="MaxErrorCount"/>
        <xs:enumeration value="ISOLevel"/>
        <xs:enumeration value="LocaleID"/>
        <xs:enumeration value="TransactionOption"/>
        <xs:enumeration value="DelayValidation"/>
      </xs:restriction>
    </xs:simpleType>
  </xs:union>
</xs:simpleType>

<xs:simpleType name="ExecutableTypePackagePropertyNameEnum">
  <xs:union memberTypes="DTS:AllExecutablePropertyNameEnum">
    <xs:simpleType>
      <xs:restriction base="xs:string">
        <xs:enumeration value="PackageFormatVersion"/>
        <xs:enumeration value="VersionComments"/>
        <xs:enumeration value="CreatorName"/>
        <xs:enumeration value="CreatorComputerName"/>
        <xs:enumeration value="CreationDate"/>
        <xs:enumeration value="PackageType"/>
        <xs:enumeration value="ProtectionLevel"/>
        <xs:enumeration value="MaxConcurrentExecutables"/>
        <xs:enumeration value="PackagePriorityClass"/>
        <xs:enumeration value="VersionMajor"/>
        <xs:enumeration value="VersionMinor"/>
        <xs:enumeration value="VersionBuild"/>
        <xs:enumeration value="VersionGUID"/>
        <xs:enumeration value="EnableConfig"/>
        <xs:enumeration value="CheckpointFileName"/>
      </xs:restriction>
    </xs:simpleType>
  </xs:union>
</xs:simpleType>

```

```

        <xs:enumeration value="SaveCheckpoints"/>
        <xs:enumeration value="CheckpointUsage"/>
        <xs:enumeration value="SuppressConfigurationWarnings"/>
        <xs:enumeration value="LastModifiedProductVersion"/>
    </xs:restriction>
</xs:simpleType>
</xs:union>
</xs:simpleType>

<xs:simpleType name="AnyNonPackageExecutablePropertyNameEnum">
    <xs:union memberTypes="DTS:AllExecutablePropertyNameEnum">
        <xs:simpleType>
            <xs:restriction base="xs:string">
                <!--Pipeline & Tasks use these values-->
                <xs:enumeration value="ExecutionLocation"/>
                <xs:enumeration value="ExecutionAddress"/>
                <xs:enumeration value="TaskContact"/>
                <xs:enumeration value="SqlStatementSource"/>
                <!--ForLoop uses these values-->
                <xs:enumeration value="InitExpression"/>
                <xs:enumeration value="EvalExpression"/>
                <xs:enumeration value="AssignExpression"/>
                <!--ForLoop and ForEachLoop use this value-->
                <xs:enumeration value="MaxConcurrent"/>
                <!--Sequence uses this value-->
                <xs:enumeration value="LockName"/>
                <!--Web Service Task uses this value-->
                <xs:enumeration value="WsdlFile"/>
            </xs:restriction>
        </xs:simpleType>
    </xs:union>
</xs:simpleType>

<xs:simpleType name="LogProviderPropertyNameEnum">
    <xs:union memberTypes="DTS:BasePropertyNameEnum">
        <xs:simpleType>
            <xs:restriction base="xs:string">
                <xs:enumeration value="DelayValidation"/>
                <xs:enumeration value="ConfigString"/>
            </xs:restriction>
        </xs:simpleType>
    </xs:union>
</xs:simpleType>

<xs:simpleType name="PackageVariablePropertyNameEnum">
    <xs:union memberTypes="DTS:BasePropertyNameEnum">
        <xs:simpleType>
            <xs:restriction base="xs:string">
                <xs:enumeration value="PackageVariableValue"/>
                <xs:enumeration value="PackageVariable"/>
                <xs:enumeration value="Namespace"/>
            </xs:restriction>
        </xs:simpleType>
    </xs:union>
</xs:simpleType>

<xs:simpleType name="ConfigurationPropertyNameEnum">
    <xs:union memberTypes="DTS:BasePropertyNameEnum">
        <xs:simpleType>
            <xs:restriction base="xs:string">
                <xs:enumeration value="ConfigurationType"/>
                <xs:enumeration value="ConfigurationString"/>
                <xs:enumeration value="ConfigurationVariable"/>
            </xs:restriction>
        </xs:simpleType>
    </xs:union>
</xs:simpleType>

<xs:simpleType name="PrecedenceConstraintPropertyNameEnum">

```

```

<xs:union memberTypes="DTS:BasePropertyNameEnum">
  <xs:simpleType>
    <xs:restriction base="xs:string">
      <xs:enumeration value="Value"/>
      <xs:enumeration value="EvalOp"/>
      <xs:enumeration value="LogicalAnd"/>
      <xs:enumeration value="Expression"/>
    </xs:restriction>
  </xs:simpleType>
</xs:union>
</xs:simpleType>

<xs:simpleType name="LoggingOptionsPropertyNameEnum">
  <xs:restriction base="xs:string">
    <xs:enumeration value="LoggingMode"/>
    <xs:enumeration value="FilterKind"/>
    <xs:enumeration value="EventFilter"/>
    <xs:enumeration value="ColumnFilter"/>
  </xs:restriction>
</xs:simpleType>

<xs:simpleType name="ColumnEventFilterPropertyNameEnum">
  <xs:restriction base="xs:string">
    <xs:enumeration value="Computer"/>
    <xs:enumeration value="Operator"/>
    <xs:enumeration value="SourceName"/>
    <xs:enumeration value="SourceID"/>
    <xs:enumeration value="ExecutionID"/>
    <xs:enumeration value="MessageText"/>
    <xs:enumeration value="DataBytes"/>
  </xs:restriction>
</xs:simpleType>

<xs:simpleType name="ForEachVariableMappingPropertyNameEnum">
  <xs:union memberTypes="DTS:BasePropertyNameEnum">
    <xs:simpleType>
      <xs:restriction base="xs:string">
        <xs:enumeration value="VariableName"/>
        <xs:enumeration value="ValueIndex"/>
      </xs:restriction>
    </xs:simpleType>
  </xs:union>
</xs:simpleType>

<xs:simpleType name="VariablePropertyNameEnum">
  <xs:union memberTypes="DTS:BasePropertyNameEnum">
    <xs:simpleType>
      <xs:restriction base="xs:string">
        <xs:enumeration value="Namespace"/>
        <xs:enumeration value="Expression"/>
        <xs:enumeration value="EvaluateAsExpression"/>
        <xs:enumeration value="ReadOnly"/>
        <xs:enumeration value="RaiseChangedEvent"/>
        <xs:enumeration value="IncludeInDebugDump"/>
        <xs:enumeration value="Expression"/>
      </xs:restriction>
    </xs:simpleType>
  </xs:union>
</xs:simpleType>

<xs:simpleType name="ConnectionManagerPropertyNameEnum">
  <xs:union memberTypes="DTS:BasePropertyNameEnum">
    <xs:simpleType>
      <xs:restriction base="xs:string">
        <xs:enumeration value="DelayValidation"/>
      </xs:restriction>
    </xs:simpleType>
  </xs:union>

```

```

</xs:simpleType>

<xs:simpleType name="ConnectionManagerObjectDataPropertyNameEnum">
  <xs:restriction base="xs:string">
    <xs:enumeration value="Retain"/>
    <xs:enumeration value="ConnectionString"/>
    <xs:enumeration value="FileUsageType"/>
    <xs:enumeration value="Format"/>
    <xs:enumeration value="LocaleID"/>
    <xs:enumeration value="Unicode"/>
    <xs:enumeration value="HeaderRowsToSkip"/>
    <xs:enumeration value="HeaderRowDelimiter"/>
    <xs:enumeration value="ColumnNamesInFirstDataRow"/>
    <xs:enumeration value="RowDelimiter"/>
    <xs:enumeration value="DataRowsToSkip"/>
    <xs:enumeration value="TextQualifier"/>
    <xs:enumeration value="CodePage"/>
    <xs:enumeration value="ServerName"/>
    <xs:enumeration value="UseFile"/>
    <xs:enumeration value="UseEncryption"/>
    <xs:enumeration value="RetainData"/>
  </xs:restriction>
</xs:simpleType>

<xs:simpleType name="FlatFileColumnPropertyNameEnum">
  <xs:union memberTypes="DTS:BasePropertyNameEnum">
    <xs:simpleType>
      <xs:restriction base="xs:string">
        <xs:enumeration value="ColumnType"/>
        <xs:enumeration value="ColumnDelimiter"/>
        <xs:enumeration value="ColumnWidth"/>
        <xs:enumeration value="MaximumWidth"/>
        <xs:enumeration value="DataType"/>
        <xs:enumeration value="DataPrecision"/>
        <xs:enumeration value="DataScale"/>
        <xs:enumeration value="TextQualified"/>
      </xs:restriction>
    </xs:simpleType>
  </xs:union>
</xs:simpleType>

<xs:simpleType name="CacheColumnPropertyNameEnum">
  <xs:union memberTypes="DTS:BasePropertyNameEnum">
    <xs:simpleType>
      <xs:restriction base="xs:string">
        <xs:enumeration value="DataType"/>
        <xs:enumeration value="Length"/>
        <xs:enumeration value="Precision"/>
        <xs:enumeration value="Scale"/>
        <xs:enumeration value="CodePage"/>
        <xs:enumeration value="IndexPosition"/>
      </xs:restriction>
    </xs:simpleType>
  </xs:union>
</xs:simpleType>

<xs:simpleType name="FtpConnectionPropertyNameEnum">
  <xs:restriction base="xs:string">
    <xs:enumeration value="ServerName"/>
    <xs:enumeration value="ServerPort"/>
    <xs:enumeration value="ServerUserName"/>
    <xs:enumeration value="ServerPassword"/>
    <xs:enumeration value="ChunkSize"/>
    <xs:enumeration value="TimeOut"/>
    <xs:enumeration value="Retries"/>
    <xs:enumeration value="UsePassiveMode"/>
  </xs:restriction>
</xs:simpleType>

```

```

<xs:simpleType name="HttpConnectionPropertyNameEnum">
  <xs:restriction base="xs:string">
    <xs:enumeration value="ServerURL"/>
    <xs:enumeration value="UseServerCredentials"/>
    <xs:enumeration value="ServerUserName"/>
    <xs:enumeration value="ServerPassword"/>
    <xs:enumeration value="ServerDomain"/>
    <xs:enumeration value="UseSecureConnection"/>
    <xs:enumeration value="CertificateIdentifier"/>
    <xs:enumeration value="Certificate"/>
    <xs:enumeration value="TimeOut"/>
    <xs:enumeration value="ChunkSize"/>
    <xs:enumeration value="UseProxy"/>
    <xs:enumeration value="ProxyURL"/>
    <xs:enumeration value="BypassProxyOnLocal"/>
    <xs:enumeration value="UseProxyCredentials"/>
    <xs:enumeration value="ProxyUserName"/>
    <xs:enumeration value="ProxyPassword"/>
    <xs:enumeration value="ProxyDomain"/>
    <xs:enumeration value="BypassList"/>
  </xs:restriction>
</xs:simpleType>

<xs:simpleType name="EventHandlerPropertyNameEnum">
  <xs:union memberTypes="DTS:BaseExecutablePropertyNameEnum">
    <xs:simpleType>
      <xs:restriction base="xs:string">
        <xs:enumeration value="EventID"/>
        <xs:enumeration value="EventName"/>
      </xs:restriction>
    </xs:simpleType>
  </xs:union>
</xs:simpleType>

<xs:simpleType name="FileSystemTaskOperationTypeEnum">
  <xs:restriction base="xs:string">
    <xs:enumeration value="CopyFile" />
    <xs:enumeration value="CreateDirectory" />
    <xs:enumeration value="DeleteDirectory" />
    <xs:enumeration value="DeleteFile" />
    <xs:enumeration value="MoveDirectory" />
    <xs:enumeration value="MoveFile" />
    <xs:enumeration value="RenameFile" />
    <xs:enumeration value="SetAttributes" />
    <xs:enumeration value="DeleteDirectoryContent" />
    <xs:enumeration value="CopyDirectory" />
  </xs:restriction>
</xs:simpleType>

<xs:simpleType name="FileSystemTaskFileAttributesEnum">
  <xs:restriction base="xs:string">
    <xs:enumeration value="Archive" />
    <xs:enumeration value="Hidden" />
    <xs:enumeration value="Normal" />
    <xs:enumeration value="ReadOnly" />
    <xs:enumeration value="System" />
  </xs:restriction>
</xs:simpleType>

<xs:simpleType name="SourceTypeEnum">
  <xs:restriction base="xs:string">
    <xs:enumeration value="DirectInput"/>
    <xs:enumeration value="FileConnection"/>
    <xs:enumeration value="Variable"/>
  </xs:restriction>
</xs:simpleType>

<!--Other Misc Types-->

```



```

<xs:simpleType name="uuid">
  <xs:restriction base="xs:string">
    <xs:pattern value="\{[0-9a-zA-Z]{8}-[0-9a-zA-Z]{4}-[0-9a-zA-Z]{4}-[0-9a-zA-Z]{4}-[0-9a-
zA-Z]{12}\}" />
    <xs:pattern value=""/>
  </xs:restriction>
</xs:simpleType>

</xs:schema>

```

5.2 WebServiceTask XSD

```

<?xml version="1.0" encoding="utf-8"?>
<xs:schema xmlns:WSTask=
  "www.microsoft.com/sqlserver/dts/tasks/webservicetask"
  xmlns:xs="http://www.w3.org/2001/XMLSchema"
  targetNamespace=
  "www.microsoft.com/sqlserver/dts/tasks/webservicetask"
  elementFormDefault="qualified"
  attributeFormDefault="qualified"
  >

  <xs:element name="WebServiceTaskData"
    type="WSTask:WSTaskDataType"/>

  <xs:complexType name="WSTaskDataType">
    <xs:sequence>
      <xs:element name="MethodInfo"
        type="WSTask:WebServiceTaskDataMethodInfoType"/>
    </xs:sequence>
    <xs:attribute name="ConnectionName" type="xs:string"/>
    <xs:attribute name="Service" type="xs:string"/>
    <xs:attribute name="WSDLFile" type="xs:string"/>
    <xs:attribute name="OverwriteWSDLFile">
      <xs:simpleType>
        <xs:restriction base="xs:string">
          <xs:enumeration value="True"/>
          <xs:enumeration value="False"/>
        </xs:restriction>
      </xs:simpleType>
    </xs:attribute>
    <xs:attribute name="OutputType"
      type="WSTask:WebServiceTaskDataOutputTypeEnum"/>
    <xs:attribute name="OutputLocation" type="xs:string"/>
  </xs:complexType>

  <xs:complexType name="WebServiceTaskDataMethodInfoType">
    <xs:sequence>
      <xs:element name="Documentation" type="xs:string"
        minOccurs="0" maxOccurs="1"/>
      <xs:element name="ParamInfo"
        type="WSTask:WebServiceTaskDataParamInfoType"
        maxOccurs="unbounded"/>
    </xs:sequence>
    <xs:attribute name="MethodName" type="xs:string"/>
    <xs:attribute name="MessageName" type="xs:string"/>
  </xs:complexType>

  <xs:complexType name="WebServiceTaskDataParamInfoType">
    <xs:sequence>
      <xs:element name="VariableValue" type="xs:string"
        minOccurs="0" maxOccurs="1"/>
      <xs:element name="PrimitiveValue" type="xs:anySimpleType"
        minOccurs="0" maxOccurs="1"/>
    </xs:sequence>
    <xs:attribute name="Name" type="xs:string"/>
  </xs:complexType>

```

```

    <xs:attribute name="Datatype" type="xs:string"/>
    <xs:attribute name="ParamType" type="WSTask:ParamTypeEnum"/>
    <xs:attribute name="SeqNumber" type="xs:int"/>
  </xs:complexType>

  <xs:simpleType name="WebServiceTaskDataOutputTypeEnum">
    <xs:restriction base="xs:string">
      <xs:enumeration value="FileConnection"/>
      <xs:enumeration value="Variable"/>
    </xs:restriction>
  </xs:simpleType>

  <xs:simpleType name="ParamTypeEnum">
    <xs:restriction base="xs:string">
      <xs:enumeration value="Variable"/>
      <xs:enumeration value="Primitive"/>
    </xs:restriction>
  </xs:simpleType>
</xs:schema>

```

5.3 MessageQueueTask XSD

```

<?xml version="1.0" encoding="utf-8"?>
<xs:schema xmlns:MessageQueueTask=
  "www.microsoft.com/sqlserver/dts/tasks/messagequeuetask"
  xmlns:xs="http://www.w3.org/2001/XMLSchema"
  targetNamespace=
  "www.microsoft.com/sqlserver/dts/tasks/messagequeuetask"
  elementFormDefault="qualified"
  attributeFormDefault="qualified"
  xmlns:DTS="www.microsoft.com/SqlServer/Dts"
  >

  <xs:import namespace="www.microsoft.com/SqlServer/Dts"
    schemaLocation="./DTSX.xsd" />

  <xs:element name="MessageQueueTaskData"
    type="MessageQueueTask:MessageQueueTaskType"/>

  <xs:complexType name="MessageQueueTaskType">
    <xs:sequence>
    </xs:sequence>
    <xs:attribute name="CurrentPackageID" type="DTS:uuid"/>
    <xs:attribute name="TaskDescription" type="xs:string"/>
    <xs:attribute name="DataFileOverWritable">
      <xs:simpleType>
        <xs:restriction base="xs:string">
          <xs:enumeration value="False"/>
          <xs:enumeration value="True"/>
        </xs:restriction>
      </xs:simpleType>
    </xs:attribute>
    <xs:attribute name="DTSMessageLineageID" type="xs:string"/>
    <xs:attribute name="DTSMessagePackageID" type="xs:string"/>
    <xs:attribute name="DTSMessageVersionID" type="xs:string"/>
    <xs:attribute name="ErrorIfMessageTimeOut">
      <xs:simpleType>
        <xs:restriction base="xs:string">
          <xs:enumeration value="False"/>
          <xs:enumeration value="True"/>
        </xs:restriction>
      </xs:simpleType>
    </xs:attribute>
    <xs:attribute name="QueuePath" type="xs:string"/>
    <xs:attribute name="ReceiveMessageTimeOut" type="xs:int"/>
    <xs:attribute name="ReceiveMessageType"

```

```

        type="MessageQueueTask:MSMQMessageTypeEnum"/>
<xs:attribute name="RemoveFromQueue">
  <xs:simpleType>
    <xs:restriction base="xs:string">
      <xs:enumeration value="False"/>
      <xs:enumeration value="True"/>
    </xs:restriction>
  </xs:simpleType>
</xs:attribute>
<xs:attribute name="SaveDataFileName" type="xs:string"/>
<xs:attribute name="StringCompareType"
  type="MessageQueueTask:MSMQStringCompareTypeEnum"/>
<xs:attribute name="StringCompareValue" type="xs:string"/>
<xs:attribute name="StringMessageToVariableName" type="xs:string"/>
<xs:attribute name="ReceiveVariableMessage" type="xs:string"/>
<xs:attribute name="TaskType"
  type="MessageQueueTask:MSMQTaskTypeEnum"/>
<xs:attribute name="UseEncryption">
  <xs:simpleType>
    <xs:restriction base="xs:string">
      <xs:enumeration value="False"/>
      <xs:enumeration value="True"/>
    </xs:restriction>
  </xs:simpleType>
</xs:attribute>
<xs:attribute name="EncryptionAlgorithm"
  type="MessageQueueTask:MSMQEncryptionAlgorithmEnum"/>
<xs:attribute name="Use2000Format">
  <xs:simpleType>
    <xs:restriction base="xs:string">
      <xs:enumeration value="False"/>
      <xs:enumeration value="True"/>
    </xs:restriction>
  </xs:simpleType>
</xs:attribute>
<xs:attribute name="DataFileName" type="xs:string"/>
<xs:attribute name="StringMessage" type="xs:string"/>
<xs:attribute name="VariableMessage" type="xs:string"/>
<xs:attribute name="MessageType"
  type="MessageQueueTask:MSMQMessageTypeEnum"/>
</xs:complexType>

<xs:simpleType name="MSMQStringCompareTypeEnum">
  <xs:restriction base="xs:string">
    <xs:enumeration value="DTSMQStringMessageCompare_Contains"/>
    <xs:enumeration value="DTSMQStringMessageCompare_Exact"/>
    <xs:enumeration value="DTSMQStringMessageCompare_IgnoreCase"/>
    <xs:enumeration value="DTSMQStringMessageCompare_None"/>
  </xs:restriction>
</xs:simpleType>

<xs:simpleType name="MSMQTaskTypeEnum">
  <xs:restriction base="xs:string">
    <xs:enumeration value="DTSMQType_Receiver"/>
    <xs:enumeration value="DTSMQType_Sender"/>
  </xs:restriction>
</xs:simpleType>

<xs:simpleType name="MSMQMessageTypeEnum">
  <xs:restriction base="xs:string">
    <xs:enumeration value="DTSMQMessage_Type_StringMessageToVariable"/>
    <xs:enumeration value="DTSMQMessage_Type_DataFile"/>
    <xs:enumeration value="DTSMQMessage_Type_String"/>
    <xs:enumeration value="DTSMQMessage_Type_Variables"/>
  </xs:restriction>
</xs:simpleType>

<xs:simpleType name="MSMQEncryptionAlgorithmEnum">
  <xs:restriction base="xs:string">

```

```

        <xs:enumeration value="Rc2"/>
        <xs:enumeration value="Rc4"/>
    </xs:restriction>
</xs:simpleType>

</xs:schema>

```

5.4 SendMailTask XSD

```

<?xml version="1.0" encoding="utf-8"?>
<xs:schema
  xmlns:SendMailTask="www.microsoft.com/sqlserver/dts/tasks/sendmailtask"
  xmlns:xs="http://www.w3.org/2001/XMLSchema"
  targetNamespace=
    "www.microsoft.com/sqlserver/dts/tasks/sendmailtask"
  elementFormDefault="qualified"
  attributeFormDefault="qualified"
  xmlns:DTS="www.microsoft.com/SqlServer/Dts"
  >

  <xs:import namespace="www.microsoft.com/SqlServer/Dts"
    schemaLocation="./DTSX.xsd" />

  <xs:element name="SendMailTaskData"
    type="SendMailTask:SendMailTaskType"/>

  <xs:complexType name="SendMailTaskType">
    <xs:sequence>
      <xs:element name="Attachments" minOccurs="0"
        type="SendMailTask:AttachmentsElementType"/>
    </xs:sequence>
    <xs:attribute name="SMTPServer" type="DTS:uuid"/>
    <xs:attribute name="From" type="xs:string"/>
    <xs:attribute name="To" type="xs:string"/>
    <xs:attribute name="CC" type="xs:string"/>
    <xs:attribute name="BCC" type="xs:string"/>
    <xs:attribute name="Subject" type="xs:string"/>
    <xs:attribute name="Priority"
      type="SendMailTask:SendMailPriorityEnum"/>
    <xs:attribute name="MessageSourceType"
      type="DTS:SourceTypeEnum"/>
    <xs:attribute name="MessageSource" type="xs:string"/>
  </xs:complexType>

  <xs:simpleType name="SendMailPriorityEnum">
    <xs:restriction base="xs:string">
      <xs:enumeration value="High"/>
      <xs:enumeration value="Low"/>
      <xs:enumeration value="Normal"/>
    </xs:restriction>
  </xs:simpleType>

  <xs:complexType name="AttachmentsElementType">
    <xs:sequence/>
    <xs:attribute name="FileName" type="xs:string"/>
  </xs:complexType>

</xs:schema>

```

5.5 ActiveXScriptTask XSD

```

<?xml version="1.0" encoding="utf-8"?>

```

```

<xs:schema xmlns:ActiveXScriptTask=
  "www.microsoft.com/sqlserver/dts/tasks/activexscripttask"
  xmlns:xs="http://www.w3.org/2001/XMLSchema"
  targetNamespace=
  "www.microsoft.com/sqlserver/dts/tasks/activexscripttask"
  elementFormDefault="qualified"
  attributeFormDefault="qualified"
  >

  <xs:element name="ActiveXScriptTaskData"
    type="ActiveXScriptTask:ActiveXScriptTaskDataType"/>

  <xs:complexType name="ActiveXScriptTaskDataType">
    <xs:sequence/>
    <xs:attribute name="ScriptingLanguage"
      type="ActiveXScriptTask:ScriptingLanguageEnum"/>
    <xs:attribute name="ScriptText" type="xs:string"/>
    <xs:attribute name="EntryMethod" type="xs:string"/>
  </xs:complexType>

  <xs:simpleType name="ScriptingLanguageEnum">
    <xs:restriction base="xs:string">
      <xs:enumeration value="VBScript"/>
      <xs:enumeration value="JScript.Compact"/>
      <xs:enumeration value="JScript"/>
    </xs:restriction>
  </xs:simpleType>

</xs:schema>

```

5.6 Exec80PackageTask XSD

```

<?xml version="1.0" encoding="utf-8"?>
<xs:schema xmlns:Exec80PackageTask=
  "www.microsoft.com/sqlserver/dts/tasks/exec80packagetask"
  xmlns:xs="http://www.w3.org/2001/XMLSchema"
  targetNamespace=
  "www.microsoft.com/sqlserver/dts/tasks/exec80packagetask"
  elementFormDefault="qualified"
  attributeFormDefault="qualified"
  xmlns:DTS="www.microsoft.com/SqlServer/Dts"
  >
  <xs:import namespace="www.microsoft.com/SqlServer/Dts"
    schemaLocation="./DTSX.xsd" />

  <xs:element name="Exec80PackageTaskData"
    type="Exec80PackageTask:Exec80PackageTaskType"/>

  <xs:complexType name="Exec80PackageTaskType">
    <xs:sequence>
      <xs:element name="DTS2000Package" type="xs:base64Binary"
        minOccurs="0" form="unqualified"/>
    </xs:sequence>
    <xs:attribute name="Location"
      type="Exec80PackageTask:Exec80PackageTaskLocationEnum"/>
    <xs:attribute name="PackageName" type="xs:string"/>
    <xs:attribute name="PackageID" type="DTS:uuid"/>
    <xs:attribute name="PackageVersionGUID" type="DTS:uuid"/>
    <xs:attribute name="SQLServer" type="xs:string"/>
    <xs:attribute name="SQLUsername" type="xs:string"/>
    <xs:attribute name="WindowsAuthentication">
      <xs:simpleType>
        <xs:restriction base="xs:string">
          <xs:enumeration value="True"/>
          <xs:enumeration value="False"/>
        </xs:restriction>
      </xs:simpleType>
    </xs:attribute>
  </xs:complexType>

```

```

    </xs:simpleType>
  </xs:attribute>
  <xs:attribute name="Filename" type="xs:string"/>
  <xs:attribute name="InnerGlobalVariables" type="xs:string"/>
  <xs:attribute name="OuterGlobalVariables" type="xs:string"/>
</xs:complexType>

<xs:simpleType name="Exec80PackageTaskLocationEnum">
  <xs:restriction base="xs:string">
    <xs:enumeration value="SqlServer"/>
    <xs:enumeration value="EmbeddedInTask"/>
    <xs:enumeration value="StorageFile"/>
  </xs:restriction>
</xs:simpleType>

</xs:schema>

```

5.7 BulkInsertTask XSD

```

<?xml version="1.0" encoding="utf-8"?>
<xs:schema xmlns:BulkInsertTask=
  "www.microsoft.com/sqlserver/dts/tasks/bulkinserttask"
  xmlns:xs="http://www.w3.org/2001/XMLSchema"
  targetNamespace=
  "www.microsoft.com/sqlserver/dts/tasks/bulkinserttask"
  elementFormDefault="qualified"
  attributeFormDefault="qualified"
  >

  <xs:element name="BulkInsertTaskData"
    type="BulkInsertTask:BulkInsertTaskDataType"/>

  <xs:complexType name="BulkInsertTaskDataType">
    <xs:sequence/>
    <xs:attribute name="BatchSize" type="BulkInsertTask:CodePageType"/>
    <xs:attribute name="CheckConstraints">
      <xs:simpleType>
        <xs:restriction base="xs:string">
          <xs:enumeration value="True"/>
          <xs:enumeration value="False"/>
        </xs:restriction>
      </xs:simpleType>
    </xs:attribute>
    <xs:attribute name="CodePage" type="xs:string"/>
    <xs:attribute name="SourceConnectionName" type="xs:string"/>
    <xs:attribute name="DestinationConnectionName" type="xs:string"/>
    <xs:attribute name="DataFileType"
      type="BulkInsertTask:DataFileTypeEnum"/>
    <xs:attribute name="DestinationTableName" type="xs:string"/>
    <xs:attribute name="FirstRow" type="xs:int"/>
    <xs:attribute name="LastRow" type="xs:int"/>
    <xs:attribute name="UseFormatFile">
      <xs:simpleType>
        <xs:restriction base="xs:string">
          <xs:enumeration value="True"/>
          <xs:enumeration value="False"/>
        </xs:restriction>
      </xs:simpleType>
    </xs:attribute>
    <xs:attribute name="FormatFile" type="xs:string"/>
    <xs:attribute name="SortedData" type="xs:string"/>
    <xs:attribute name="TableLock">
      <xs:simpleType>
        <xs:restriction base="xs:string">
          <xs:enumeration value="True"/>
          <xs:enumeration value="False"/>
        </xs:restriction>
      </xs:simpleType>
    </xs:attribute>
  </xs:complexType>

```

```

    </xs:simpleType>
  </xs:attribute>
  <xs:attribute name="KeepIdentity">
    <xs:simpleType>
      <xs:restriction base="xs:string">
        <xs:enumeration value="True"/>
        <xs:enumeration value="False"/>
      </xs:restriction>
    </xs:simpleType>
  </xs:attribute>
  <xs:attribute name="KeepNulls">
    <xs:simpleType>
      <xs:restriction base="xs:string">
        <xs:enumeration value="True"/>
        <xs:enumeration value="False"/>
      </xs:restriction>
    </xs:simpleType>
  </xs:attribute>
  <xs:attribute name="FieldTerminator"
    type="BulkInsertTask:BulkInsertTaskTerminatorEnum"/>
  <xs:attribute name="RowTerminator"
    type="BulkInsertTask:BulkInsertTaskTerminatorEnum"/>
  <xs:attribute name="FireTriggers">
    <xs:simpleType>
      <xs:restriction base="xs:string">
        <xs:enumeration value="True"/>
        <xs:enumeration value="False"/>
      </xs:restriction>
    </xs:simpleType>
  </xs:attribute>
  <xs:attribute name="MaximumErrors" type="xs:int"/>
</xs:complexType>

<xs:simpleType name="DataFileTypeEnum">
  <xs:restriction base="xs:string">
    <xs:enumeration value="DTSBulkInsert DataFileType Char"/>
    <xs:enumeration value="DTSBulkInsert DataFileType Native"/>
    <xs:enumeration value="DTSBulkInsert DataFileType WideChar"/>
    <xs:enumeration value="DTSBulkInsert DataFileType WideNative"/>
  </xs:restriction>
</xs:simpleType>

<xs:simpleType name="CodePageType">
  <xs:union memberTypes="xs:int">
    <xs:simpleType>
      <xs:restriction base="xs:string">
        <xs:enumeration value="ACP"/>
        <xs:enumeration value="OEM"/>
        <xs:enumeration value="RAW"/>
      </xs:restriction>
    </xs:simpleType>
  </xs:union>
</xs:simpleType>

<xs:simpleType name="BulkInsertTaskTerminatorEnum">
  <xs:restriction base="xs:string">
    <xs:enumeration value="{CR}{LF}"/>
    <xs:enumeration value="{CR}"/>
    <xs:enumeration value="{LF}"/>
    <xs:enumeration value="Semicolon {; }"/>
    <xs:enumeration value="Comma {, }"/>
    <xs:enumeration value="Tab"/>
    <xs:enumeration value="Vertical Bar {|}"/>
  </xs:restriction>
</xs:simpleType>
</xs:schema>

```

5.8 SQLTask XSD

```
<?xml version="1.0" encoding="utf-8"?>
<xs:schema xmlns:SQLTask="www.microsoft.com/sqlserver/dts/tasks/sqltask"
  xmlns:xs="http://www.w3.org/2001/XMLSchema"
  targetNamespace="www.microsoft.com/sqlserver/dts/tasks/sqltask"
  elementFormDefault="qualified"
  attributeFormDefault="qualified"
  xmlns:DTS="www.microsoft.com/SqlServer/Dts"
  >

  <xs:import namespace="www.microsoft.com/SqlServer/Dts"
    schemaLocation="./DTSX.xsd" />

  <xs:element name="SqlTaskData"
    type="SQLTask:SqlTaskDataElementBackupTaskType"/>

  <xs:complexType name="SqlTaskDataType">
    <xs:sequence>
      <xs:element name="SelectedDatabases"
        type="SQLTask:SelectedDatabasesType"
        minOccurs="0" maxOccurs="unbounded"/>
      <xs:element name="OperatorNotifyList"
        type="SQLTask:OperatorNotifyListType"
        minOccurs="0" maxOccurs="unbounded"/>
      <xs:element name="ParameterBinding"
        type="SQLTask:SqlTaskParameterBindingType"
        minOccurs="0" maxOccurs="unbounded"/>
      <xs:element name="ResultBinding"
        type="SQLTask:SqlTaskResultBindingType"
        minOccurs="0" maxOccurs="1"/>
      <xs:element name="BackupDestinationList"
        type="SQLTask:BackupDestinationListType"
        minOccurs="0" maxOccurs="unbounded"/>
    </xs:sequence>
    <xs:attributeGroup
      ref="SQLTask:SqlTaskBaseAttributeGroup"/>
    <xs:attributeGroup
      ref="SQLTask:MaintenanceTaskBaseAttributeGroup"/>
    <xs:attributeGroup
      ref="SQLTask:BackupTaskAttributeGroup"/>
    <xs:attributeGroup
      ref="SQLTask:CheckIntegrityTaskAttributeGroup"/>
    <xs:attributeGroup
      ref="SQLTask:AgentJobTaskAttributeGroup"/>
    <xs:attributeGroup
      ref="SQLTask:HistoryCleanupTaskAttributeGroup"/>
    <xs:attributeGroup
      ref="SQLTask:MaintenanceFileCleanupTaskAttributeGroup"/>
    <xs:attributeGroup
      ref="SQLTask:NotifyOperatorTaskAttributeGroup"/>
    <xs:attributeGroup
      ref="SQLTask:RebuildIndexTaskAttributeGroup"/>
    <xs:attributeGroup
      ref="SQLTask:ReorganizeIndexTaskAttributeGroup"/>
    <xs:attributeGroup
      ref="SQLTask:ShrinkDBTaskAttributeGroup"/>
    <xs:attributeGroup
      ref="SQLTask:UpdateStatisticsTaskAttributeGroup"/>
    <xs:attribute name="RemoveOlderThan" type="xs:int"/>
    <xs:attribute name="TimeUnitsType"
      type="SQLTask:SqlTaskTimeUnitsTypeEnum"/>
    <xs:attribute name="DatabaseSelectionType"
      type="SQLTask:SqlTaskDatabaseSelectionTypeEnum"/>
  </xs:complexType>

  <xs:simpleType name="SqlResultTypeEnum">
    <xs:restriction base="xs:string">
      <xs:enumeration value="ResultSetType_None"/>
    </xs:restriction>
  </xs:simpleType>

```



```

    <xs:enumeration value="ResultSetType_Rowset"/>
    <xs:enumeration value="ResultSetType_SingleRow"/>
    <xs:enumeration value="ResultSetType_XML"/>
  </xs:restriction>
</xs:simpleType>

<xs:complexType name="SelectedDatabasesType">
  <xs:sequence/>
  <xs:attribute name="DatabaseName" type="xs:string"/>
</xs:complexType>

<xs:complexType name="OperatorNotifyListType">
  <xs:sequence/>
  <xs:attribute name="OperatorNotify" type="xs:string"/>
</xs:complexType>

<xs:complexType name="SqlTaskParameterBindingType">
  <xs:sequence/>
  <xs:attribute name="ParameterName" type="xs:string"/>
  <xs:attribute name="DtsVariableName" type="xs:string"/>
  <xs:attribute name="ParameterDirection"
    type="SQLTask:ParameterDirectionEnum"/>
  <xs:attribute name="DataType" type="DTS:DtsDataTypeEnum"/>
  <xs:attribute name="ParameterSize" type="xs:int"/>
</xs:complexType>

<xs:simpleType name="ParameterDirectionEnum">
  <xs:restriction base="xs:string">
    <xs:enumeration value="Input"/>
    <xs:enumeration value="Output"/>
    <xs:enumeration value="ReturnValue"/>
  </xs:restriction>
</xs:simpleType>

<xs:complexType name="SqlTaskResultBindingType">
  <xs:sequence/>
  <xs:attribute name="ResultName" type="xs:string"/>
  <xs:attribute name="DtsVariableName" type="xs:string"/>
</xs:complexType>

<xs:complexType name="BackupDestinationListType">
  <xs:sequence/>
  <xs:attribute name="BackupDestinationLocation"
    type="xs:string"/>
</xs:complexType>

<!--Attribute Groups-->

<xs:attributeGroup name="SqlTaskBaseAttributeGroup">
  <xs:attribute name="Connection" type="DTS:uuid"/>
  <xs:attribute name="TimeOut" type="xs:int"/>
  <xs:attribute name="IsStoredProc">
    <xs:simpleType>
      <xs:restriction base="xs:string">
        <xs:enumeration value="True"/>
        <xs:enumeration value="False"/>
      </xs:restriction>
    </xs:simpleType>
  </xs:attribute>
  <xs:attribute name="BypassPrepare">
    <xs:simpleType>
      <xs:restriction base="xs:string">
        <xs:enumeration value="True"/>
        <xs:enumeration value="False"/>
      </xs:restriction>
    </xs:simpleType>
  </xs:attribute>
  <xs:attribute name="SqlStmtSourceType"

```

```

        type="DTS:SourceTypeEnum"/>
    <xs:attribute name="SqlStatementSource"
        type="xs:string"/>
    <xs:attribute name="CodePage" type="xs:int"/>
    <xs:attribute name="ResultType"
        type="SQLTask:SqlResultTypeEnum"/>
</xs:attributeGroup>

<xs:attributeGroup name="MaintenanceTaskBaseAttributeGroup">
    <xs:attribute name="ServerVersion" type="xs:int"/>
    <xs:attribute name="ExtendedLogging">
        <xs:simpleType>
            <xs:restriction base="xs:string">
                <xs:enumeration value="True"/>
                <xs:enumeration value="False"/>
            </xs:restriction>
        </xs:simpleType>
    </xs:attribute>
    <xs:attribute name="LocalConnectionForLogging" type="xs:string"/>
    <xs:attribute name="TaskName" type="xs:string"/>
    <xs:attribute name="IgnoreDatabasesInNotOnlineState">
        <xs:simpleType>
            <xs:restriction base="xs:string">
                <xs:enumeration value="True"/>
                <xs:enumeration value="False"/>
            </xs:restriction>
        </xs:simpleType>
    </xs:attribute>
</xs:attributeGroup>

<xs:attributeGroup name="BackupTaskAttributeGroup">
    <xs:attribute name="BackupAction" type="SQLTask:BackupActionEnum"/>
    <xs:attribute name="BackupIsIncremental">
        <xs:simpleType>
            <xs:restriction base="xs:string">
                <xs:enumeration value="True"/>
                <xs:enumeration value="False"/>
            </xs:restriction>
        </xs:simpleType>
    </xs:attribute>
    <xs:attribute name="BackupFileGroupsFiles" type="xs:string"/>
    <xs:attribute name="BackupDeviceType"
        type="SQLTask:BackupDeviceTypeEnum"/>
    <xs:attribute name="BackupPhisycalDestinationType"
        type="SQLTask:BackupPhisycalDestinationTypeEnum"/>
    <xs:attribute name="BackupDestinationType"
        type="SQLTask:DestinationTypeEnum"/>
    <xs:attribute name="BackupDestinationAutoFolderPath"
        type="xs:string"/>
    <xs:attribute name="BackupActionForExistingBackups"
        type="SQLTask:BackupActionForExistingBackupsEnum"/>
    <xs:attribute name="BackupCreateSubFolder">
        <xs:simpleType>
            <xs:restriction base="xs:string">
                <xs:enumeration value="True"/>
                <xs:enumeration value="False"/>
            </xs:restriction>
        </xs:simpleType>
    </xs:attribute>
    <xs:attribute name="BackupFileExtension" type="xs:string"/>
    <xs:attribute name="BackupVerifyIntegrity">
        <xs:simpleType>
            <xs:restriction base="xs:string">
                <xs:enumeration value="True"/>
                <xs:enumeration value="False"/>
            </xs:restriction>
        </xs:simpleType>
    </xs:attribute>
    <xs:attribute name="ExpireDate" type="xs:dateTime"/>

```

```

<xs:attribute name="RetainDays" type="xs:int"/>
<xs:attribute name="InDays">
  <xs:simpleType>
    <xs:restriction base="xs:string">
      <xs:enumeration value="True"/>
      <xs:enumeration value="False"/>
    </xs:restriction>
  </xs:simpleType>
</xs:attribute>
<xs:attribute name="UseExpiration">
  <xs:simpleType>
    <xs:restriction base="xs:string">
      <xs:enumeration value="True"/>
      <xs:enumeration value="False"/>
    </xs:restriction>
  </xs:simpleType>
</xs:attribute>
<xs:attribute name="BackupCompressionAction"
  type="SQLTask:BackupCompressionActionEnum"/>
<xs:attribute name="BackupTailLog">
  <xs:simpleType>
    <xs:restriction base="xs:string">
      <xs:enumeration value="True"/>
      <xs:enumeration value="False"/>
    </xs:restriction>
  </xs:simpleType>
</xs:attribute>
</xs:attributeGroup>

<xs:simpleType name="BackupActionEnum">
  <xs:restriction base="xs:int">
    <xs:minInclusive value="0"/>
    <xs:maxInclusive value="2"/>
  </xs:restriction>
</xs:simpleType>

<xs:simpleType name="BackupDeviceTypeEnum">
  <xs:restriction base="xs:int">
    <xs:minInclusive value="0"/>
    <xs:maxInclusive value="4"/>
  </xs:restriction>
</xs:simpleType>

<xs:simpleType name="BackupPhisycalDestinationTypeEnum">
  <xs:restriction base="xs:int">
    <!--QQQ Need Enum-->
  </xs:restriction>
</xs:simpleType>

<xs:simpleType name="DestinationTypeEnum">
  <xs:restriction base="xs:int">
    <xs:minInclusive value="0"/>
    <xs:maxInclusive value="1"/>
  </xs:restriction>
</xs:simpleType>

<xs:simpleType name="BackupActionForExistingBackupsEnum">
  <xs:restriction base="xs:int">
    <xs:minInclusive value="0"/>
    <xs:maxInclusive value="1"/>
  </xs:restriction>
</xs:simpleType>

<xs:simpleType name="BackupCompressionActionEnum">
  <xs:restriction base="xs:int">
    <xs:minInclusive value="0"/>
    <xs:maxInclusive value="2"/>
  </xs:restriction>
</xs:simpleType>

```

```

<xs:attributeGroup name="CheckIntegrityTaskAttributeGroup">
  <xs:attribute name="IncludeIndexes">
    <xs:simpleType>
      <xs:restriction base="xs:string">
        <xs:enumeration value="True"/>
        <xs:enumeration value="False"/>
      </xs:restriction>
    </xs:simpleType>
  </xs:attribute>
</xs:attributeGroup>

<xs:simpleType name="SqlTaskDatabaseSelectionTypeEnum">
  <xs:restriction base="xs:int">
    <xs:minInclusive value="1"/>
    <xs:maxInclusive value="4"/>
  </xs:restriction>
</xs:simpleType>

<xs:attributeGroup name="AgentJobTaskAttributeGroup">
  <xs:attribute name="AgentJobID" type="xs:string"/>
</xs:attributeGroup>

<xs:attributeGroup name="HistoryCleanupTaskAttributeGroup">
  <xs:attribute name="RemoveBackupRestoreHistory">
    <xs:simpleType>
      <xs:restriction base="xs:string">
        <xs:enumeration value="True"/>
        <xs:enumeration value="False"/>
      </xs:restriction>
    </xs:simpleType>
  </xs:attribute>
  <xs:attribute name="RemoveAgentHistory">
    <xs:simpleType>
      <xs:restriction base="xs:string">
        <xs:enumeration value="True"/>
        <xs:enumeration value="False"/>
      </xs:restriction>
    </xs:simpleType>
  </xs:attribute>
  <xs:attribute name="RemoveDbMaintHistory">
    <xs:simpleType>
      <xs:restriction base="xs:string">
        <xs:enumeration value="True"/>
        <xs:enumeration value="False"/>
      </xs:restriction>
    </xs:simpleType>
  </xs:attribute>
</xs:attributeGroup>

<xs:simpleType name="SqlTaskTimeUnitsTypeEnum">
  <xs:restriction base="xs:int">
    <xs:enumeration value="0"/>
    <xs:enumeration value="1"/>
    <xs:enumeration value="2"/>
    <xs:enumeration value="3"/>
    <xs:enumeration value="5"/>
  </xs:restriction>
</xs:simpleType>

<xs:attributeGroup name="MaintenanceFileCleanupTaskAttributeGroup">
  <xs:attribute name="FileTypeSelected" type="xs:string"/>
  <xs:attribute name="FilePath" type="xs:string"/>
  <xs:attribute name="FolderPath" type="xs:string"/>
  <xs:attribute name="CleanSubFolders">
    <xs:simpleType>
      <xs:restriction base="xs:string">
        <xs:enumeration value="True"/>
        <xs:enumeration value="False"/>
      </xs:restriction>
    </xs:simpleType>
  </xs:attribute>
</xs:attributeGroup>

```

```

        </xs:restriction>
    </xs:simpleType>
</xs:attribute>
<xs:attribute name="FileExtension" type="xs:string"/>
<xs:attribute name="AgeBased">
    <xs:simpleType>
        <xs:restriction base="xs:string">
            <xs:enumeration value="True"/>
            <xs:enumeration value="False"/>
        </xs:restriction>
    </xs:simpleType>
</xs:attribute>
<xs:attribute name="DeleteSpecificFile">
    <xs:simpleType>
        <xs:restriction base="xs:string">
            <xs:enumeration value="True"/>
            <xs:enumeration value="False"/>
        </xs:restriction>
    </xs:simpleType>
</xs:attribute>
</xs:attributeGroup>

<xs:simpleType name="SqlTaskFileTypeSelectedEnum">
    <xs:restriction base="xs:int">
        <xs:minInclusive value="0"/>
        <xs:maxInclusive value="1"/>
    </xs:restriction>
</xs:simpleType>

<xs:attributeGroup name="NotifyOperatorTaskAttributeGroup">
    <xs:attribute name="Message" type="xs:string"/>
    <xs:attribute name="Profile" type="xs:string"/>
    <xs:attribute name="Subject" type="xs:string"/>
</xs:attributeGroup>

<xs:attributeGroup name="RebuildIndexTaskAttributeGroup">
    <xs:attribute name="UseOriginalAmount">
        <xs:simpleType>
            <xs:restriction base="xs:string">
                <xs:enumeration value="True"/>
                <xs:enumeration value="False"/>
            </xs:restriction>
        </xs:simpleType>
    </xs:attribute>
    <xs:attribute name="Percentage" type="xs:int"/>
    <xs:attribute name="Sort">
        <xs:simpleType>
            <xs:restriction base="xs:string">
                <xs:enumeration value="True"/>
                <xs:enumeration value="False"/>
            </xs:restriction>
        </xs:simpleType>
    </xs:attribute>
    <xs:attribute name="KeepOnline">
        <xs:simpleType>
            <xs:restriction base="xs:string">
                <xs:enumeration value="True"/>
                <xs:enumeration value="False"/>
            </xs:restriction>
        </xs:simpleType>
    </xs:attribute>
</xs:attributeGroup>

<xs:attributeGroup name="ReorganizeIndexTaskAttributeGroup">
    <xs:attribute name="CompactLargeObjects">
        <xs:simpleType>
            <xs:restriction base="xs:string">
                <xs:enumeration value="True"/>
                <xs:enumeration value="False"/>
            </xs:restriction>
        </xs:simpleType>
    </xs:attribute>
</xs:attributeGroup>

```

```

        </xs:restriction>
    </xs:simpleType>
</xs:attribute>
</xs:attributeGroup>

<xs:attributeGroup name="ShrinkDBTaskAttributeGroup">
    <xs:attribute name="DatabaseSizeLimit" type="xs:int"/>
    <xs:attribute name="DatabasePercentLimit" type="xs:int"/>
    <xs:attribute name="DatabaseReturnFreeSpace">
        <xs:simpleType>
            <xs:restriction base="xs:string">
                <xs:enumeration value="True"/>
                <xs:enumeration value="False"/>
            </xs:restriction>
        </xs:simpleType>
    </xs:attribute>
</xs:attributeGroup>

<xs:attributeGroup name="UpdateStatisticsTaskAttributeGroup">
    <xs:attribute name="UpdateStatisticsType"
        type="SQLTask:SqlTaskUpdateStatisticsTypeEnum"/>
    <xs:attribute name="UpdateScanType"
        type="SQLTask:SqlTaskUpdateScanTypeEnum"/>
    <xs:attribute name="UpdateSampleValue" type="xs:int"/>
</xs:attributeGroup>

<xs:simpleType name="SqlTaskUpdateStatisticsTypeEnum">
    <xs:restriction base="xs:int">
        <xs:minInclusive value="0"/>
        <xs:maxInclusive value="2"/>
    </xs:restriction>
</xs:simpleType>

<xs:simpleType name="SqlTaskUpdateScanTypeEnum">
    <xs:restriction base="xs:int">
        <xs:minInclusive value="2"/>
        <xs:maxInclusive value="3"/>
    </xs:restriction>
</xs:simpleType>

<!--The following complex types are not accessed by the formal XSD.
They are used for copy/paste into section 2.6.4.x to document behavior
of specific ExecutableType types-->

<xs:complexType name="SqlTaskDataElementSqlTaskType">
    <xs:sequence/>
    <xs:attributeGroup
        ref="SQLTask:SqlTaskBaseAttributeGroup"/>
</xs:complexType>

<xs:complexType name="SqlTaskDataElementBackupTaskType">
    <xs:sequence>
        <xs:element name="SelectedDatabases"
            type="SQLTask:SelectedDatabasesType"
            minOccurs="0" maxOccurs="unbounded"/>
    </xs:sequence>
    <xs:attributeGroup
        ref="SQLTask:SqlTaskBaseAttributeGroup"/>
    <xs:attributeGroup
        ref="SQLTask:MaintenanceTaskBaseAttributeGroup"/>
    <xs:attributeGroup
        ref="SQLTask:BackupTaskAttributeGroup"/>
    <!--Need to ck elements and other attr for backup task-->
</xs:complexType>

<xs:complexType name="SqlTaskDataElementCheckIntegrityTaskType">
    <xs:sequence>
        <xs:element name="SelectedDatabases"
            type="SQLTask:SelectedDatabasesType"

```

```

        minOccurs="0" maxOccurs="unbounded"/>
    <xs:element name="BackupDestinationList"
        type="SQLTask:BackupDestinationListType"
        minOccurs="0" maxOccurs="unbounded"/>
</xs:sequence>
<xs:attributeGroup
    ref="SQLTask:SqlTaskBaseAttributeGroup"/>
<xs:attributeGroup
    ref="SQLTask:MaintenanceTaskBaseAttributeGroup"/>
<xs:attributeGroup
    ref="SQLTask:CheckIntegrityTaskAttributeGroup"/>
<xs:attribute name="DatabaseSelectionType"
    type="SQLTask:SqlTaskDatabaseSelectionTypeEnum"/>
</xs:complexType>

<xs:complexType name="SqlTaskDataElementAgentJobTaskType">
    <xs:sequence/>
    <xs:attributeGroup
        ref="SQLTask:SqlTaskBaseAttributeGroup"/>
    <xs:attributeGroup
        ref="SQLTask:MaintenanceTaskBaseAttributeGroup"/>
    <xs:attributeGroup
        ref="SQLTask:AgentJobTaskAttributeGroup"/>
</xs:complexType>

<xs:complexType name="SqlTaskDataElementHistoryCleanupTaskType">
    <xs:sequence/>
    <xs:attributeGroup
        ref="SQLTask:SqlTaskBaseAttributeGroup"/>
    <xs:attributeGroup
        ref="SQLTask:MaintenanceTaskBaseAttributeGroup"/>
    <xs:attributeGroup
        ref="SQLTask:HistoryCleanupTaskAttributeGroup"/>
    <xs:attribute name="RemoveOlderThan" type="xs:int"/>
    <xs:attribute name="TimeUnitsType"
        type="SQLTask:SqlTaskTimeUnitsTypeEnum"/>
</xs:complexType>

<xs:complexType
    name="SqlTaskDataElementMaintenanceFileCleanupTaskType">
    <xs:sequence/>
    <xs:attributeGroup
        ref="SQLTask:SqlTaskBaseAttributeGroup"/>
    <xs:attributeGroup
        ref="SQLTask:MaintenanceTaskBaseAttributeGroup"/>
    <xs:attributeGroup
        ref="SQLTask:MaintenanceFileCleanupTaskAttributeGroup"/>
    <xs:attribute name="RemoveOlderThan" type="xs:int"/>
    <xs:attribute name="TimeUnitsType"
        type="SQLTask:SqlTaskTimeUnitsTypeEnum"/>
</xs:complexType>

<xs:complexType name="SqlTaskDataElementNotifyOperatorTaskType">
    <xs:sequence>
        <xs:element name="OperatorNotifyList"
            type="SQLTask:OperatorNotifyListType"
            minOccurs="0" maxOccurs="unbounded"/>
    </xs:sequence>
    <xs:attributeGroup
        ref="SQLTask:SqlTaskBaseAttributeGroup"/>
    <xs:attributeGroup
        ref="SQLTask:MaintenanceTaskBaseAttributeGroup"/>
    <xs:attributeGroup
        ref="SQLTask:NotifyOperatorTaskAttributeGroup"/>
</xs:complexType>

<xs:complexType name="SqlTaskDataElementRebuildIndexTaskType">
    <xs:sequence>
        <xs:element name="SelectedDatabases"

```

```

        type="SQLTask:SelectedDatabasesType"
        minOccurs="0" maxOccurs="unbounded"/>
</xs:sequence>
<xs:attributeGroup
  ref="SQLTask:SqlTaskBaseAttributeGroup"/>
<xs:attributeGroup
  ref="SQLTask:MaintenanceTaskBaseAttributeGroup"/>
<xs:attributeGroup
  ref="SQLTask:RebuildIndexTaskAttributeGroup"/>
<xs:attribute name="DatabaseSelectionType"
  type="SQLTask:SqlTaskDatabaseSelectionTypeEnum"/>
</xs:complexType>

<xs:complexType
  name="SqlTaskDataElementReorganizeIndexTaskType">
  <xs:sequence>
    <xs:element name="SelectedDatabases"
      type="SQLTask:SelectedDatabasesType"
      minOccurs="0" maxOccurs="unbounded"/>
  </xs:sequence>
  <xs:attributeGroup
    ref="SQLTask:SqlTaskBaseAttributeGroup"/>
  <xs:attributeGroup
    ref="SQLTask:MaintenanceTaskBaseAttributeGroup"/>
  <xs:attributeGroup
    ref="SQLTask:ReorganizeIndexTaskAttributeGroup"/>
  <xs:attribute name="DatabaseSelectionType"
    type="SQLTask:SqlTaskDatabaseSelectionTypeEnum"/>
</xs:complexType>

<xs:complexType
  name="SqlTaskDataElementShrinkDatabaseTaskType">
  <xs:sequence>
    <xs:element name="SelectedDatabases"
      type="SQLTask:SelectedDatabasesType"
      minOccurs="0" maxOccurs="unbounded"/>
  </xs:sequence>
  <xs:attributeGroup
    ref="SQLTask:SqlTaskBaseAttributeGroup"/>
  <xs:attributeGroup
    ref="SQLTask:MaintenanceTaskBaseAttributeGroup"/>
  <xs:attributeGroup
    ref="SQLTask:ShrinkDBTaskAttributeGroup"/>
  <xs:attribute name="DatabaseSelectionType"
    type="SQLTask:SqlTaskDatabaseSelectionTypeEnum"/>
</xs:complexType>

<xs:complexType
  name="SqlTaskDataElementUpdateStatisticsTaskType">
  <xs:sequence>
    <xs:element name="SelectedDatabases"
      type="SQLTask:SelectedDatabasesType"
      minOccurs="0" maxOccurs="unbounded"/>
  </xs:sequence>
  <xs:attributeGroup
    ref="SQLTask:SqlTaskBaseAttributeGroup"/>
  <xs:attributeGroup
    ref="SQLTask:MaintenanceTaskBaseAttributeGroup"/>
  <xs:attributeGroup
    ref="SQLTask:UpdateStatisticsTaskAttributeGroup"/>
  <xs:attribute name="DatabaseSelectionType"
    type="SQLTask:SqlTaskDatabaseSelectionTypeEnum"/>
</xs:complexType>

<xs:complexType name="SqlTaskDataElementTSQLExecuteTaskType">
  <xs:sequence/>
  <xs:attributeGroup
    ref="SQLTask:SqlTaskBaseAttributeGroup"/>
  <xs:attributeGroup

```



```
    ref="SQLTask:MaintenanceTaskBaseAttributeGroup"/>  
</xs:complexType>  
</xs:schema>
```

6 Appendix B: Product Behavior

The information in this specification is applicable to the following Microsoft products or supplemental software. References to product versions include updates to those products.

- Microsoft SQL Server 2008
- Microsoft SQL Server 2008 R2
- Microsoft SQL Server 2012
- Microsoft SQL Server 2014
- Microsoft SQL Server 2016
- Microsoft SQL Server 2017
- Microsoft SQL Server 2019

Exceptions, if any, are noted in this section. If an update version, service pack or Knowledge Base (KB) number appears with a product name, the behavior changed in that update. The new behavior also applies to subsequent updates unless otherwise specified. If a product edition appears with the product version, behavior is different in that product edition.

Unless otherwise specified, any statement of optional behavior in this specification that is prescribed using the terms "SHOULD" or "SHOULD NOT" implies product behavior in accordance with the SHOULD or SHOULD NOT prescription. Unless otherwise specified, the term "MAY" implies that the product does not follow the prescription.

[<1> Section 2](#): Integration Services provides user options for encryption. The default is that sensitive properties are not included in the clear text file. Options are provided to include sensitive information in the structure file in encrypted form.

[<2> Section 2.1.2](#): In the Integration Services system, elements can appear in any order within the <xs:sequence> tags. The Integration Services user interface generates package files that do not adhere to the sequence that is stated in the XSD.

[<3> Section 2.4.3.2](#): In Microsoft implementations, the **InnerObject** element is always empty.

[<4> Section 2.4.4.2.1.1](#): The value of the **RowDelimiter** property is not used by Integration Services.

[<5> Section 2.4.4.2.1.1](#): The **RetainData** enumeration value is not used by Integration Services.

[<6> Section 2.4.4.2.3](#): The SMO object model is available only on the SQL Server database.

[<7> Section 2.4.5](#): The value of this property is not processed by Integration Services.

[<8> Section 2.4.5](#): The value of this property is not processed by Integration Services. By default, the Integration Services UI places the domain-qualified logon name of the package creator in this field.

[<9> Section 2.4.5](#): The value of this property is not processed by Integration Services.

[<10> Section 2.4.5](#): This field is for documentation and is not processed by Integration Services.

[<11> Section 2.4.5](#): The **VersionBuild** value is incremented every time the package is saved when operating in the Integration Services UI or through the Integration Services runtime object model.

[<12> Section 2.4.5](#): In Microsoft implementations, the **VersionGUID** value changes every time the package is saved.

<13> [Section 2.4.5](#): The Integration Services UI sets this property to the version of the installed version of SQL server that is present on the local machine.

<14> [Section 2.5](#): This integer value is not currently used by the Integration Services system.

<15> [Section 2.5.3](#): Integration Services sets the **ExecutionLocation** value to 0.

<16> [Section 2.5.3](#): Integration Services sets the **ExecutionAddress** value to EMPTY.

<17> [Section 2.5.3](#): Integration Services sets **MaxConcurrent** to 1.

<18> [Section 2.5.3](#): The **LockName** property is left blank by Integration Services. If a value is present, it is ignored by Integration Services.

<19> [Section 2.7.1.1](#): In Microsoft implementations, the default for the **defaultBufferMaxRows** attribute value is 10,000 rows.

<20> [Section 2.7.1.1](#): In Microsoft implementations, the default value for the **engineThreads** attribute is 5. The data flow engine can, in some circumstances, exceed the **engineThreads** value. If the value is set higher than the data flow engine needs, the data flow engine only uses the number of threads that it needs.

<21> [Section 2.7.1.1](#): In Microsoft implementations, the default for the **defaultBufferSize** attribute is 10 megabytes.

<22> [Section 2.7.1.1](#): In Microsoft implementations, the default value that is used for the **BLOBTempStoragePath** attribute value is the folder that the Windows TMP environment variable points to.

<23> [Section 2.7.1.1](#): In Microsoft implementations, the default value that is used for the **bufferTempStoragePath** attribute value is the folder that the Windows TEMP environment variable points to.

<24> [Section 2.7.1.1.1.1](#): In Microsoft implementations, the **validateExternalMetadata** attribute specifies whether the Visual Studio UI validates column data against its external data source at design time.

TRUE specifies that the UI validates column data against external data sources at design time.

FALSE specifies that the UI does not validate external metadata against its external data source at design time.

<25> [Section 2.7.1.1.1.1](#): The Integration Services system does not process the contents of the **contactInfo** attribute value.

<26> [Section 2.7.1.1.1.1.1.2](#): A value of 0 for the **MaxMemoryUsageproperty** element value indicates that the system dynamically sets the memory usage.

<27> [Section 2.7.1.1.1.1.1.2](#): In Microsoft implementations, a value of 0 for the **MaxMemoryUsage** attribute specifies that the cache size has no limit.

<28> [Section 2.7.1.1.1.1.1.2](#): Microsoft implementations require this value to be a valid SQL Server identifier name.

<29> [Section 2.7.1.1.1.1.1.2](#): The **ReferenceMetadataXml** attribute value is not used by Integration Services.

<30> [Section 2.7.1.1.1.1.1.2](#): The **ReferenceMetadataXml** attribute value is not used by Integration Services.

<31> [Section 2.7.1.1.1.1.1.1.2](#): In Microsoft implementations, the **VSTAProjectName** attribute is the project name of the Visual Studio project.

<32> [Section 2.7.1.1.1.1.1.1.2](#): In Microsoft implementations, a value of 0 for the **MaximumThreads** attribute specifies that the maximum number of threads is unlimited.

<33> [Section 2.7.1.1.1.1.1.1.2](#): In Microsoft implementations, the value of 0 for the **BatchSize** attribute indicates that the batch size is set to the internal buffer size.

<34> [Section 2.7.1.1.1.1.1.1.2](#): In Microsoft implementations, the value of 0 for the **CommandTimeout** attribute indicates that there is no timeout.

<35> [Section 2.7.1.1.1.1.1.1.2](#): In Microsoft implementations, the value of 0 for the **CommandTimeout** attribute indicates that there is no timeout.

<36> [Section 2.7.1.1.1.1.1.1.2](#): The **FastLoadOptions** property applies to Microsoft products such as Microsoft SQL Server and Microsoft Office Excel. It might not be applicable to servers or to applications from other vendors.

<37> [Section 2.7.1.1.1.1.1.1.2](#): In Microsoft implementations, the value of 0 for the **CommandTimeout** attribute indicates that there is no timeout.

<38> [Section 2.7.1.1.1.1.1.1.2](#): The **FastLoadOptions** property applies to Microsoft products such as SQL Server and Office Excel. It might not be applicable to servers or to applications from other vendors.

<39> [Section 2.7.1.1.1.1.1.1.2](#): The contents of the **ObjectRef** string apply only to the Microsoft Object Model, AMO.

<40> [Section 2.7.1.1.1.1.1.1.2](#): For an explanation of Analysis Services processing types, see [\[MSDN-POS\]](#).

<41> [Section 2.7.1.1.1.1.1.1.2](#): The contents of the **ObjectRef** string apply only to the Microsoft Object Model, AMO.

<42> [Section 2.7.1.1.1.1.1.1.2](#): For an explanation of Analysis Services processing types, see [\[MSDN-POS\]](#).

<43> [Section 2.7.1.1.1.1.1.1.2](#): In Microsoft implementations, the value -1 indicates that no value is assigned to the **BulkInsertFirstRow** attribute.

<44> [Section 2.7.1.1.1.1.1.1.2](#): In Microsoft implementations, if the **LastRow** attribute is set to -1, the value is not set.

<45> [Section 2.7.1.1.1.1.1.1.2](#): In Microsoft implementations, the value 0 for the **Timeout** attribute indicates that SQL Server does not time out.

<46> [Section 2.7.1.1.1.1.1.1.2](#): In Microsoft implementations, when the **MaxInsertCommitSize** attribute value is set to 0, all rows are inserted in a single batch.

<47> [Section 2.7.1.1.1.1.1.1.2](#): In Microsoft implementations, the value of 0 for the **CommandTimeout** attribute indicates that there is no timeout.

<48> [Section 2.7.1.1.1.1.1.1.2](#): For more information about how Integration Services converts external types to strings, see [\[MSDN-ADONETSRC\]](#).

<49> [Section 2.7.1.1.1.1.1.1.2](#): In Microsoft implementations, the value of 0 for the **CommandTimeout** attribute indicates that there is no timeout.

<50> [Section 2.7.1.1.1.1.1.1.2](#): In Microsoft implementations, the value of 0 for the **CommandTimeout** attribute indicates that there is no timeout.

<51> [Section 2.7.1.1.1.3.1.3](#): In Microsoft implementations, a value of -1 for the **DestinationColumn** property indicates that the column is not mapped to an output column.

<52> [Section 2.7.1.1.1.4.1.1](#): In Microsoft implementations, a value of -1 for the **SourceColumn** attribute indicates that the column is not used for pivoting.

<53> [Section 2.7.1.1.1.5](#): In Microsoft implementations, the list of components for the **PipelineComponentClassIDEnum** value of "{2E42D45B-F83C-400F-8D77-61DDE6A7DF29}" can be distinguished by the **UserComponentTypeName** attribute value on the component element.

<54> [Section 2.7.1.1.1.6.5](#): This value is assigned by the Integration Services engine when a column is created and is used internally by the Integration Services engine to track the relationships between input columns and output columns that are downstream from this column and that reference this column.

<55> [Section 2.7.1.5.1.1.1](#): In Microsoft implementations, the value 0 for **BatchSize** indicates default behavior, which is that all rows in the data file are processed as one transaction.

<56> [Section 2.7.1.5.1.1.1](#): In Microsoft implementations, the value 0 for **LastRow** indicates default behavior, which is to process to the end of the file.

<57> [Section 2.7.1.5.1.1.1.1](#): In SQL Server, for the **DTSBulkInsert_DataFileType_Native** enumeration value, the data file to load is created by bulk copying SQL Server data by using the **bcp utility**. For more information about the bcp utility, see [\[MSDN-BCPU\]](#).

<58> [Section 2.7.1.5.1.1.1.1](#): In SQL Server, for the **DTSBulkInsert_DataFileType_WideNative** enumeration value, the data file to load is created by bulk copying SQL Server data by using the bcp utility.

<59> [Section 2.7.1.5.1.1.1.2](#): The Bulk Insert Task works only in conjunction with SQL Server as the server. When the **CodePageType** attribute is set to the value "ACP", the code page is converted from the ANSI code page to the SQL Server code page.

<60> [Section 2.7.1.5.1.1.1.2](#): The Bulk Insert Task works only in conjunction with SQL Server as the server. When the **CodePageType** attribute is set to the value "OEM", the code page is converted to the SQL Server code page.

<61> [Section 2.7.1.6](#): In Microsoft implementations, this string is in the Data Mining Extensions (DMX) [\[MSDN-DMXR\]](#) language.

<62> [Section 2.7.1.7.1.1.1](#): The contents of the **DataSourcesType** type are dynamically generated by Integration Services and contain a reference to each ConnectionManager in the Integration Services Package file. If any contents are present in this element in the package file, the content is ignored and dynamically regenerated as just stated.

<63> [Section 2.7.1.7.1.1.2](#): Integration Services requires the **ProfileMode** element to be set to the value "Exact". Fast mode is not supported.

<64> [Section 2.7.1.7.1.1.2.2](#): Integration Services sets the FrequentValueThreshold value to 0.001 by default if the FrequentValueThreshold value is not specified.

<65> [Section 2.7.1.7.1.1.2.2](#): In Microsoft implementations, if the **MaxNumberOfPatterns** element is not specified, the default value is 10.

<66> [Section 2.7.1.7.1.1.2.2](#): In Microsoft implementations, if the **PercentageDataCoverageDesired** element is not specified, the default value is 95.

<67> [Section 2.7.1.7.1.1.2.2](#): In Microsoft implementations, if the **CaseSensitive** element is not specified, the default value is FALSE.

<68> [Section 2.7.1.7.1.1.2.2.2](#): By default, in Microsoft implementations, the list of **Delimiter** elements contains the following characters: the space, horizontal tab (\t), new line (\n), and carriage return (\r). Additional **Delimiter** elements can be specified, but the default delimiters cannot be removed.

<69> [Section 2.7.1.7.1.1.2.2.2](#): By default, in Microsoft implementations, the list of symbols contains the following characters: , . ; : - " ' ` ~ = & / \ @ ! ? () < > [] { } | # * ^ %

<70> [Section 2.7.1.7.1.1.2.2.2](#): In Microsoft implementations, the default value of 0.95 is used for the **KeyStrengthThreshold** element value if the **KeyStrengthThreshold** element value is not specified.

<71> [Section 2.7.1.7.1.1.2.2.2](#): Integration Services supports the value FALSE only for the **VerifyOutputInFastMode** element.

<72> [Section 2.7.1.7.1.1.2.2.2](#): In Microsoft implementations, the default value for the **MaxNumberOfViolations** element is 100.

<73> [Section 2.7.1.7.1.1.2.2.2](#): In Microsoft implementations, the default value of 0.95 is used for the value of the **FDStrengthThreshold** element if the value of the **FDStrengthThreshold** element is not specified.

<74> [Section 2.7.1.7.1.1.2.2.2](#): Integration Services supports the value FALSE only for the **VerifyOutputInFastMode** element.

<75> [Section 2.7.1.7.1.1.2.2.2](#): In Microsoft implementations, the default value for the **MaxNumberOfViolations** element is 100.

<76> [Section 2.7.1.7.1.1.2.2.2](#): Microsoft implementations require the **SupersetDataSourceID** attribute to be equal to the **SubsetDataSourceID** attribute.

<77> [Section 2.7.1.7.1.1.2.2.2](#): In Microsoft implementations, the default value of 0.95 is used for the value of the **InclusionStrengthThreshold** element if the value of the **InclusionStrengthThreshold** element is not specified.

<78> [Section 2.7.1.7.1.1.2.2.2](#): In Microsoft implementations, the default value of 0.95 is used for the value of the **SupersetColumnsKeyThreshold** element if the value of the **SupersetColumnsKeyThreshold** element is not specified.

<79> [Section 2.7.1.7.1.1.2.2.2](#): Integration Services supports the value FALSE only for the **VerifyOutputInFastMode** element.

<80> [Section 2.7.1.7.1.1.2.2.2](#): In Microsoft implementations, the default value for the **MaxNumberOfViolations** element is 100.

<81> [Section 2.7.1.7.1.1.3](#): In Microsoft implementations, the contents of the **DataProfileOutputType** complex type are not used in the package file. If the **DataProfileOutputType** complex type is present, any content is ignored.

<82> [Section 2.7.1.7.1.1.3](#): In Microsoft implementations, the **Profiles** element is enforced to be EMPTY. Any content that is present is ignored during package file processing.

<83> [Section 2.7.1.8.1.1.1](#): In Microsoft implementations, every time the package is saved, a new GUID value is generated for the **PackageVersionGUID** attribute.

<84> [Section 2.7.1.8.1.1.1](#): In Microsoft implementations, the **SQLServer** attribute value is the name of a SQL Server instance.

<85> [Section 2.7.1.8.1.1.1](#): In Microsoft implementations, the database username is a specific SQL Server username. The **SQLUsername** attribute value is used only if the **WindowsAuthentication** attribute has a value of "False".

[<86> Section 2.7.1.8.1.1.1.1](#): In Microsoft implementations, the "SQLServer" enumeration value specifies that the DTS 2000 Package file is stored on a SQL Server database server.

[<87> Section 2.7.1.14.1.1.1](#): The **DTSMessageLineageID** attribute value is not used by the Integration Services system. Any value given for this attribute is ignored by Integration Services.

[<88> Section 2.7.1.14.1.1.1](#): In Microsoft implementations, the **Use2000Format** attribute specifies whether the message is formatted with the SQL Server 2000 format.

"True" specifies that the message is formatted with the SQL Server 2000 format.

"False" specifies that the message is not formatted with the SQL Server 2000 format.

[<89> Section 2.7.1.15](#): In Microsoft implementations, the **VSTAMajorVersion** integer value specifies the Visual Studio Tools for Applications (VSTA) major version number.

[<90> Section 2.7.1.15](#): In Microsoft implementations, the **VSTAMinorVersion** integer value specifies the VSTA minor version number.

[<91> Section 2.7.1.15.3](#): This string value is used by Visual Studio for supporting the debugging environment and is not set or interpreted by Integration Services.

[<92> Section 2.7.1.22](#): Database logins are the logins authorized to the SQL Server instance.

[<93> Section 2.8.5.1](#): The content of the **EventID** Property element value is ignored by the Integration Services system.

[<94> Section 2.9.1](#): The content of the **Description** string is not processed by the Integration Services system.

[<95> Section 2.9.1](#): The **ObjectName** value is not processed by Integration Services.

[<96> Section 2.9.9](#): The **InnerObjectObjectDataType** type is empty for all standard components that ship with the Integration Services product.

7 Change Tracking

This section identifies changes that were made to this document since the last release. Changes are classified as Major, Minor, or None.

The revision class **Major** means that the technical content in the document was significantly revised. Major changes affect protocol interoperability or implementation. Examples of major changes are:

- A document revision that incorporates changes to interoperability requirements.
- A document revision that captures changes to protocol functionality.

The revision class **Minor** means that the meaning of the technical content was clarified. Minor changes do not affect protocol interoperability or implementation. Examples of minor changes are updates to clarify ambiguity at the sentence, paragraph, or table level.

The revision class **None** means that no new technical changes were introduced. Minor editorial and formatting changes may have been made, but the relevant technical content is identical to the last released version.

The changes made to this document are listed in the following table. For more information, please contact dochelp@microsoft.com.

| Section | Description | Revision class |
|---------------------------------------|---|----------------|
| 2.8.4 VariableType | 13464024 : Changed ManagedSerizlizable to ManagedSerializable in the XSD. | Major |
| 2.8.4 VariableType | Added a description of the ManagedSerializable enumeration value. | Major |
| 5.1 DTS XSD | 13464024 : Changed ManagedSerizlizable to ManagedSerializable in the XSD. | Major |

8 Index

A

[Applicability](#) 18

C

[Change tracking](#) 508

[Common data types and fields](#) 19

[Custom Component example](#) 418

D

[Data types and fields - common](#) 19

Details

[common data types and fields](#) 19

E

Examples

[Custom Component](#) 418

[Lookup and Fuzzy Lookup Components with Error](#)

[Output](#) 370

[Web Service Task and Script Task](#) 400

F

[Fields - security index](#) 437

[Fields - vendor-extensible](#) 18

G

[Glossary](#) 12

I

[Implementer - security considerations](#) 437

[Index of security fields](#) 437

[Informative references](#) 15

[Introduction](#) 12

L

[Localization](#) 18

[Lookup and Fuzzy Lookup Components with Error](#)

[Output example](#) 370

N

[Normative references](#) 14

O

[Overview \(synopsis\)](#) 15

P

[Product behavior](#) 502

R

[References](#) 14

[informative](#) 15

[normative](#) 14

[Relationship to protocols and other structures](#) 18

S

Security

[field index](#) 437

[implementer considerations](#) 437

Structures

[overview](#) 19

T

[Tracking changes](#) 508

V

[Vendor-extensible fields](#) 18

[Versioning](#) 18

W

[Web Service Task and Script Task example](#) 400